

Summary

Atmel's SAM4L series is a member of a family of Flash microcontrollers based on the high performance 32-bit ARM Cortex-M4 RISC processor running at frequencies up to 48MHz.

The SAM4L series embeds state-of-the-art picoPower technology for ultra-low power consumption. Combined power control techniques are used to bring active current consumption down to 90µA/MHz. The device allows a wide range of options between functionality and power consumption, giving the user the ability to reach the lowest possible power consumption with the feature set required for the application. The WAIT and RETENTION modes provide full logic and RAM retention, associated with fast wake-up capability (<1.5µs) and a very low consumption of, respectively, 3 µA and 1.5 µA. In addition, WAIT mode supports SleepWalking features. In BACKUP mode, CPU, peripherals and RAM are powered off and, while consuming less than 0.9µA with external interrupt wake-up supported.

The SAM4L series offers a wide range of peripherals such as segment LCD controller, embedded hardware capacitive touch (QTouch), USB device & embedded host, 128-bit AES and audio interfaces in addition to high speed serial peripherals such as USART, SPI and I²C. Additionally the Peripheral Event System and SleepWalking allows the peripherals to communicate directly with each other and make intelligent decisions and decide to wake-up the system on a qualified events on a peripheral level; such as I²C address match or and ADC threshold.

Features

- Core
 - ARM[®] Cortex™-M4 running at up to 48MHz
 - Memory Protection Unit (MPU)
 - Thumb[®]-2 instruction set
- picoPower[®] Technology for Ultra-low Power Consumption
 - Active mode down to 90µA/MHz with configurable voltage scaling
 - High performance and efficiency: 28 coremark/mA
 - Wait mode down to 3µA with fast wake-up time (<1.5µs) supporting SleepWalking
 - Full RAM and Logic Retention mode down to 1.5µA with fast wake-up time (<1.5µs)
 - Ultra low power Backup mode with/without RTC down to 1,5/0.9µA
- Memories
 - From 128 to 512Kbytes embedded Flash, 64-bit wide access,
 - 0 wait-state capability up to 24MHz
 - up to 64Kbytes embedded SRAM
- System Functions
 - Embedded voltage linear and switching regulator for single supply operation
 - Two Power-on-Reset and Two Brown-out Detectors (BOD)
 - Quartz or ceramic resonator oscillators: 0.6 to 30MHz main power with Failure Detection and low power 32.768 kHz for RTC or device clock
 - High precision 4/8/12MHz factory trimmed internal RC oscillator
 - Slow Clock Internal RC oscillator as permanent low-power mode device clock
 - High speed 80MHz internal RC oscillator
 - Low power 32kHz internal RC oscillator
 - PLL up to 240MHz for device clock and for USB



**ATSAM
ARM-based
Flash MCU**

SAM4L Series

Summary

42023ES-07/2013



- Digital Frequency Locked Loop (DFLL) with wide input range
- Up to 16 peripheral DMA (PDCA) channels
- Peripherals
 - USB 2.0 Device and Embedded Host: 12 Mbps, up to 8 bidirectional Endpoints and Multi-packet Ping-pong Mode. On-Chip Transceiver
 - Liquid Crystal Display (LCD) Module with Capacity up to 40 Segments and up to 4 Common Terminals
 - One USART with ISO7816, IrDA®, RS-485, SPI, Manchester and LIN Mode
 - Three USART with SPI Mode
 - One PicoUART for extended UART wake-up capabilities in all sleep modes
 - Windowed Watchdog Timer (WDT)
 - Asynchronous Timer (AST) with Real-time Clock Capability, Counter or Calendar Mode Supported
 - Frequency Meter (FREQM) for Accurate Measuring of Clock Frequency
 - Six 16-bit Timer/Counter (TC) Channels with capture, waveform, compare and PWM mode
 - One Master/Slave Serial Peripheral Interface (SPI) with Chip Select Signals
 - Four Master and Two Slave Two-wire Interfaces (TWI), up to 3.4Mbit/s I²C-compatible
 - One Advanced Encryption System (AES) with 128-bit key length
 - One 16-channel ADC 300Ksps (ADC) with up to 12 Bits Resolution
 - One DAC 500Ksps (DACC) with up to 10 Bits Resolution
 - Four Analog Comparators (ACIFC) with Optional Window Detection
 - Capacitive Touch Module (CATB) supporting up to 32 buttons
 - Audio Bitstream DAC (ABDACB) Suitable for Stereo Audio
 - Inter-IC Sound (IISC) Controller, Compliant with Inter-IC Sound (I²S) Specification
 - Peripheral Event System for Direct Peripheral to Peripheral Communication
 - 32-bit Cyclic Redundancy Check Calculation Unit (CRCCU)
 - Random generator (TRNG)
 - Parallel Capture Module (PARC)
 - Glue Logic Controller (GLOC)
- I/O
 - Up to 75 I/O lines with external interrupt capability (edge or level sensitivity), debouncing, glitch filtering and slew-rate control
 - Up to Six High-drive I/O Pins
- Single 1.68-3.6V Power Supply
- Packages
 - 100-lead LQFP, 14 x 14 mm, pitch 0.5 mm/100-ball VFBGA, 7x7 mm, pitch 0.65 mm
 - 64-lead LQFP, 10 x 10 mm, pitch 0.5 mm/64-pad QFN 9x9 mm, pitch 0.5 mm
 - 64-ball WLCSP, 4,314x4,434 mm, pitch 0.5 mm
 - 48-lead LQFP, 7 x 7 mm, pitch 0.5 mm/48-pad QFN 7x7 mm, pitch 0.5 mm

1. Description

Atmel's SAM4L series is a member of a family of Flash microcontrollers based on the high performance 32-bit ARM Cortex-M4 RISC processor running at frequencies up to 48MHz.

The processor implements a Memory Protection Unit (MPU) and a fast and flexible interrupt controller for supporting modern and real-time operating systems.

The ATSAM4L8/L4/L2 embeds state-of-the-art picoPower technology for ultra-low power consumption. Combined power control techniques are used to bring active current consumption down to 90µA/MHz. The device allows a wide range of options between functionality and power consumption, giving the user the ability to reach the lowest possible power consumption with the feature set required for the application. On-chip regulator improves power efficiency when used in swichting mode with an external inductor or can be used in linear mode if application is noise sensitive.

The ATSAM4L8/L4/L2 supports 4 power saving strategies. The SLEEP mode put the CPU in idle mode and offers different sub-modes which automatically switch off/on bus clocks, PLL, oscillators. The WAIT and RETENTION modes provide full logic and RAM retention, associated with fast wake-up capability (<1.5µs) and a very low consumption of, respectively, 3 µA and 1.5 µA. In addition, WAIT mode supports SleepWalking features. In BACKUP mode, CPU, peripherals and RAM are powered off and, while consuming less than 0.5µA, the device is able to wake-up from external interrupts.

The ATSAM4L8/L4/L2 incorporates on-chip Flash tightly coupled to a low power cache (LPCACHE) for active consumption optimization and SRAM memories for fast access.

The LCD controller is intended for monochrome passive liquid crystal display (LCD) with up to 4 Common terminals and up to 40 Segments terminals. Dedicated Low Power Waveform, Contrast Control, Extended Interrupt Mode, Selectable Frame Frequency and Blink functionality are supported to offload the CPU, reduce interrupts and reduce power consumption. The LCD includes integrated LCD buffers, an integrated power supply voltage and an innovative SWAP mode. Using SWAP mode, the hardware designers have more flexibility during board layout as they can rearrange the pin sequence on Segment and/or Common Terminal Buses.

The low-power and high performance capacitive touch module (CATB) is introduced to meet the demand for a low power capacitive touch solution that could be used to handle buttons, sliders and wheels. The CATB provides excellent signal performance, as well as autonomous touch and proximity detection for up to 32 sensors. This solution includes an advanced sequencer in addition to an hardware filtering unit.

The Advanced Encryption Standard module (AESA) is compliant with the *FIPS (Federal Information Processing Standard) Publication 197, Advanced Encryption Standard (AES)*, which specifies a symmetric block cipher that is used to encrypt and decrypt electronic data. *Encryption* is the transformation of a usable message, called the *plaintext*, into an unreadable form, called the *ciphertext*. On the other hand, *decryption* is the transformation that recovers the plaintext from the ciphertext. AESA supports 128 bits cryptographic key sizes.

The Peripheral Direct Memory Access (DMA) controller enables data transfers between peripherals and memories without processor involvement. The Peripheral DMA controller drastically reduces processing overhead when transferring continuous and large data streams.

The Peripheral Event System (PES) allows peripherals to receive, react to, and send peripheral events without CPU intervention. Asynchronous interrupts allow advanced peripheral operation in low power modes.

The Power Manager (PM) improves design flexibility and security. The Power Manager supports SleepWalking functionality, by which a module can be selectively activated based on peripheral events, even in sleep modes where the module clock is stopped. Power monitoring is supported by on-chip Power-on Reset (POR18, POR33), Brown-out Detectors (BOD18, BOD33). The device features several oscillators, such as Phase Locked Loop (PLL), Digital Frequency Locked Loop (DFLL), Oscillator 0 (OSC0), Internal RC 4,8,12MHz oscillator (RCFAST), system RC oscillator (RCSYS), Internal RC 80MHz, Internal 32kHz RC and 32kHz Crystal Oscillator. Either of these oscillators can be used as source for the system clock. The DFLL is a programmable internal oscillator from 40 to 150MHz. It can be tuned to a high accuracy if an accurate reference clock is running, e.g. the 32kHz crystal oscillator.

The Watchdog Timer (WDT) will reset the device unless it is periodically serviced by the software. This allows the device to recover from a condition that has caused the system to be unstable.

The Asynchronous Timer (AST) combined with the 32kHz crystal oscillator supports powerful real-time clock capabilities, with a maximum timeout of up to 136 years. The AST can operate in counter or calendar mode.

The Frequency Meter (FREQM) allows accurate measuring of a clock frequency by comparing it to a known reference clock.

The Full-speed USB 2.0 device and embedded host interface (USBC) supports several USB classes at the same time utilizing the rich end-point configuration.

The device includes six identical 16-bit Timer/Counter (TC) channels. Each channel can be independently programmed to perform frequency measurement, event counting, interval measurement, pulse generation, delay timing, and pulse width modulation.

The ATSAM4L8/L4/L2 also features many communication interfaces, like USART, SPI, or TWI, for communication intensive applications. The USART supports different communication modes, like SPI Mode and LIN Mode.

A general purpose 16-channel ADC is provided, as well as four analog comparators (ACIFC). The ADC can operate in 12-bit mode at full speed. The analog comparators can be paired to detect when the sensing voltage is within or outside the defined reference window.

Atmel offers the QTouch Library for embedding capacitive touch buttons, sliders, and wheels functionality. The patented charge-transfer signal acquisition offers robust sensing and includes fully debounced reporting of touch keys as well as Adjacent Key Suppression® (AKS®) technology for unambiguous detection of key events. The easy-to-use QTouch Suite toolchain allows you to explore, develop, and debug your own touch applications.

The Audio Bitstream DAC (ABDACB) converts a 16-bit sample value to a digital bitstream with an average value proportional to the sample value. Two channels are supported, making the ABDAC particularly suitable for stereo audio.

The Inter-IC Sound Controller (IISC) provides a 5-bit wide, bidirectional, synchronous, digital audio link with external audio devices. The controller is compliant with the Inter-IC Sound (I2S) bus specification.

2. Overview

2.1 Block Diagram

Figure 2-1. Block Diagram

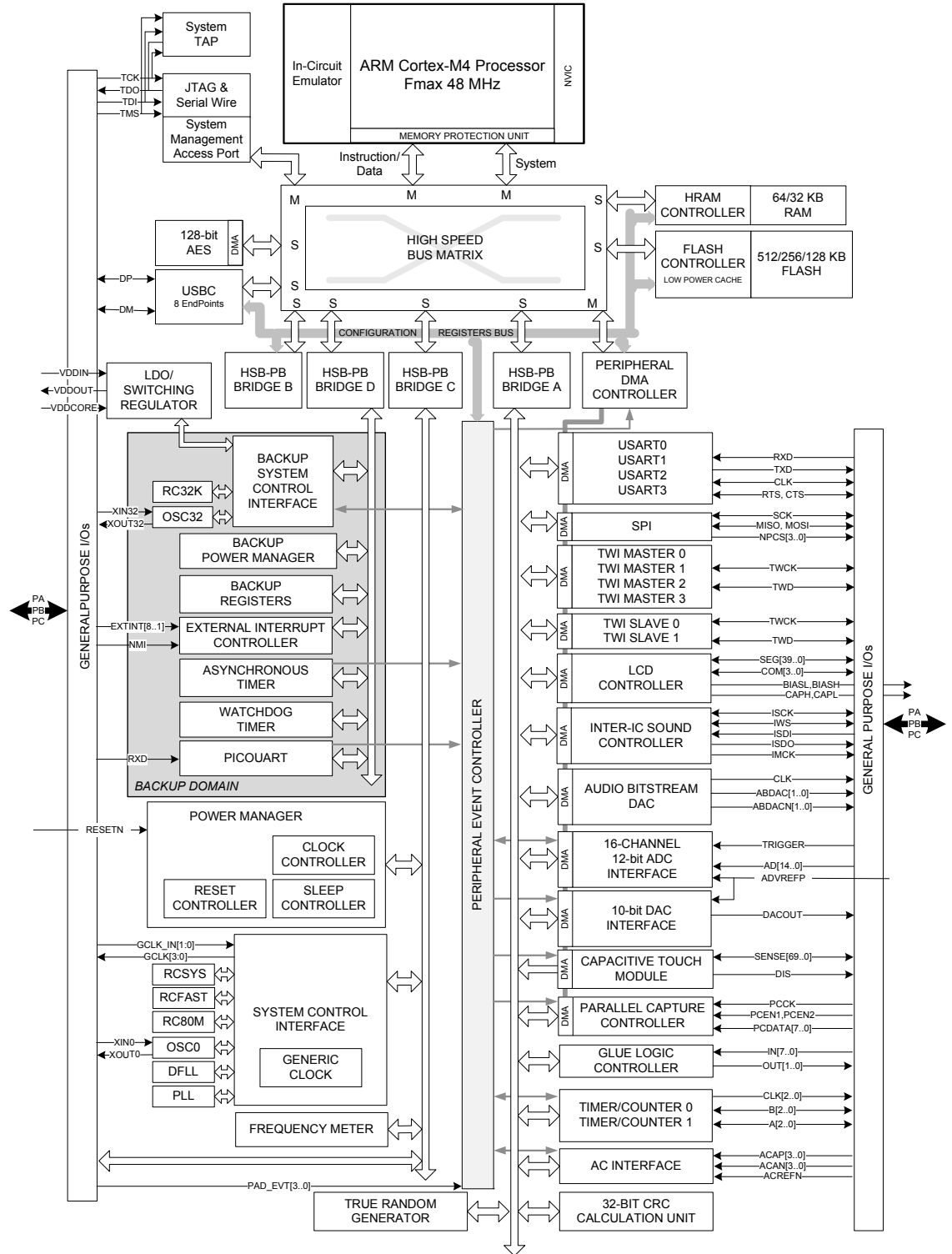

2.2 Configuration Summary

Table 2-1. Sub Series Summary

Feature	ATSAM4LC	ATSAM4LS
SEGMENT LCD	Yes	No
AESA	Yes	No
USB	Device + Host	Device Only

Table 2-2. Configuration Summary

Feature	ATSAM4LxxC/	ATSAM4LxxB	ATSAM4LxxA
Number of Pins	100	64	48
Max Frequency	48MHz		
Flash	512/256/128KB		
SRAM	64/32/32KB		
SEGMENT LCD	4x40 ⁽¹⁾	4x23 ⁽¹⁾	4x13 ⁽¹⁾
GPIO	75 ⁽¹⁾	43 ⁽¹⁾	27 ⁽¹⁾
High-drive pins	6	3	1
External Interrupts	8 + 1 NMI		
TWI	2 Masters + 2 Masters/Slaves		1 Master + 1 Master/Slave
USART	4		3 in LC sub series 4 in LS sub series
PICOUART	1		
Peripheral DMA Channels	16		
AESA	1		
Peripheral Event System	1		
SPI	1		
Asynchronous Timers	1		
Timer/Counter Channels	6	3	
Parallel Capture Inputs	8		
Frequency Meter	1		
Watchdog Timer	1		
Power Manager	1		
Glue Logic LUT	2		1

Table 2-2. Configuration Summary

Feature	ATSAM4LxxC/	ATSAM4LxxB	ATSAM4LxxA
Oscillators	Digital Frequency Locked Loop 20-150MHz (DFLL) Phase Locked Loop 48-240MHz (PLL) Crystal Oscillator 0.6-30MHz (OSC0) Crystal Oscillator 32kHz (OSC32K) RC Oscillator 80MHz (RC80M) RC Oscillator 4,8,12MHz (RCFAST) RC Oscillator 115kHz (RCSYS) RC Oscillator 32kHz (RC32K)		
ADC	15-channel	7-channel	3-channel
DAC	1-channel		
Analog Comparators	4	2	1
CATB Sensors	32	32	26
USB	1		
Audio Bitstream DAC	1		
IIS Controller	1		
Packages	TQFP/VFBGA	TQFP/QFN/ WLCSP	TQFP/QFN

Notes: 1. For ATSAM4LS sub serie, no LCD SEGMENT pins are available and 5 additional GPIO pins are available.

3. Package and Pinout

3.1 Package

The device pins are multiplexed with peripheral functions as described in [Section 3.2 "Peripheral Multiplexing on I/O lines"](#) on page 18.

3.1.1 ATSAM4LCx Pinout

Figure 3-1. ATSAM4LC TQFP100 Pinout

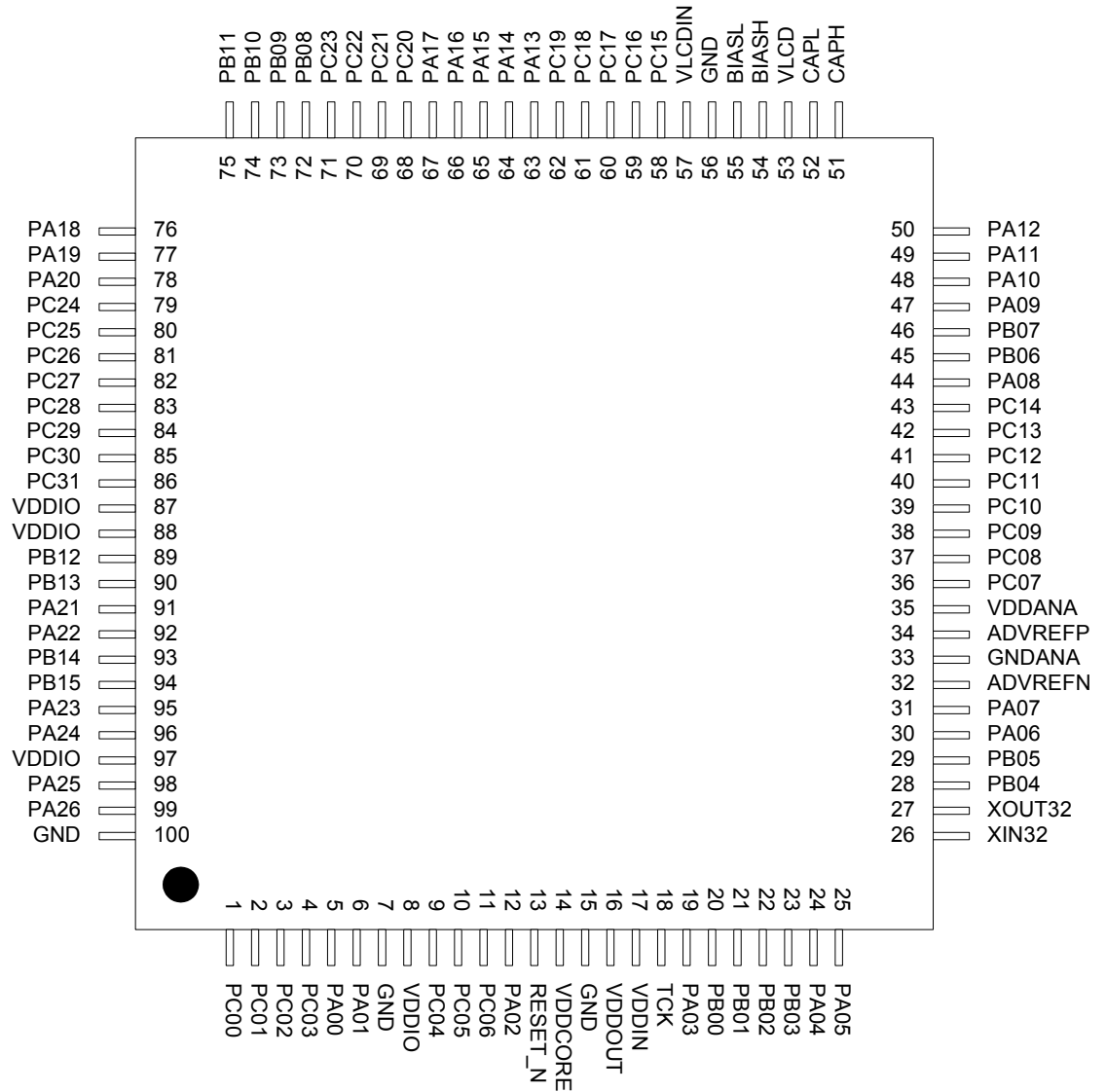

Figure 3-2. ATSAM4LC VFBGA100 Pinout

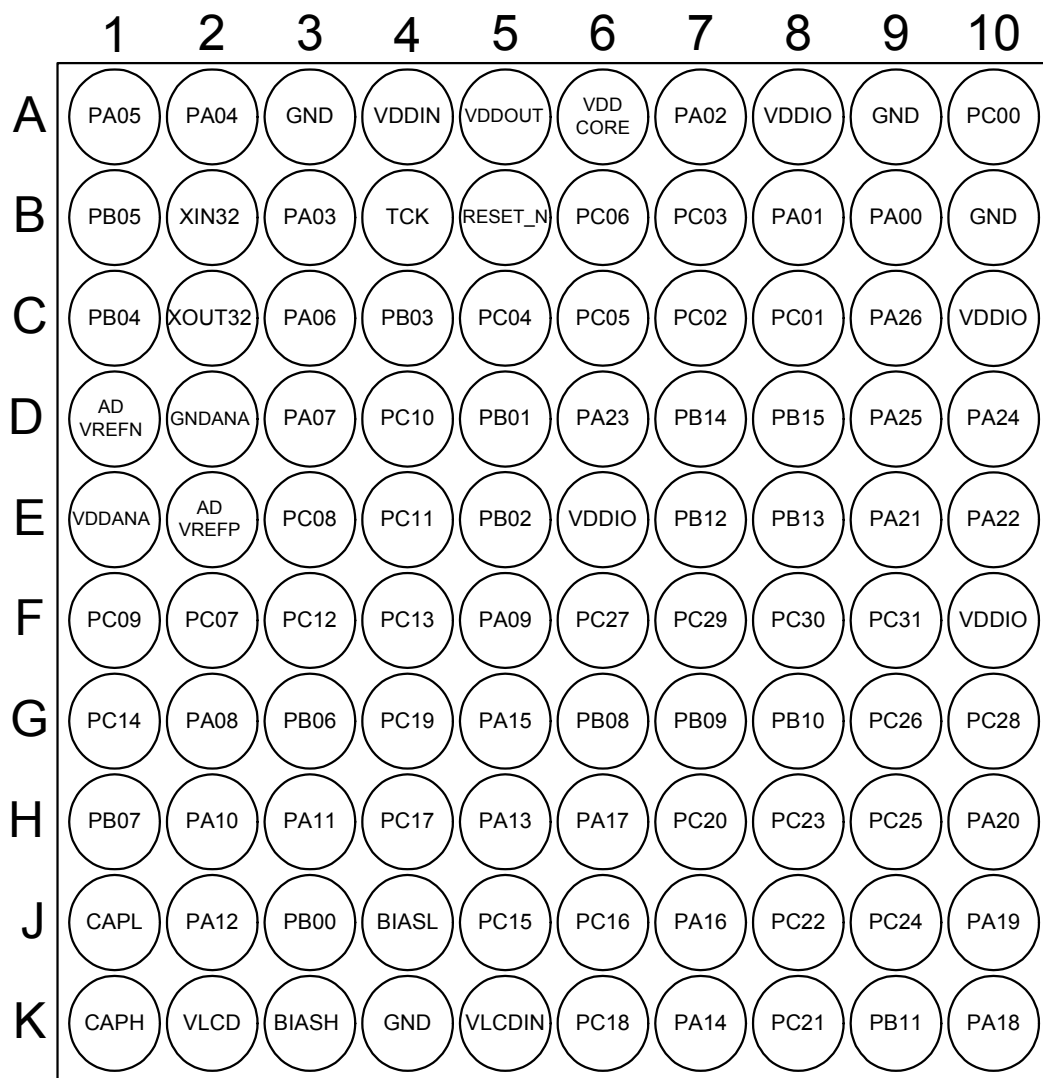

Figure 3-3. ATSAM4LC WLCSP64 Pinout

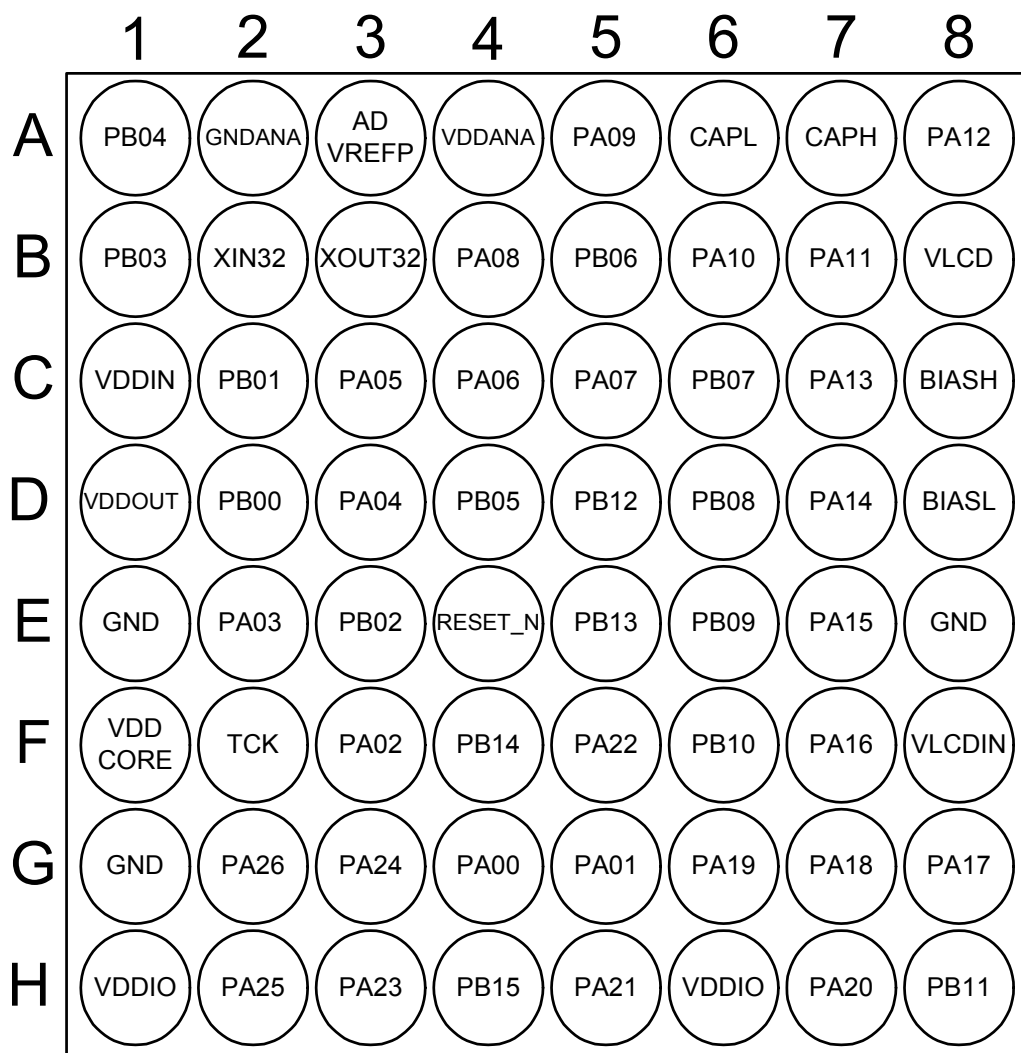

Figure 3-4. ATSAM4LC TQFP64/QFN64 Pinout

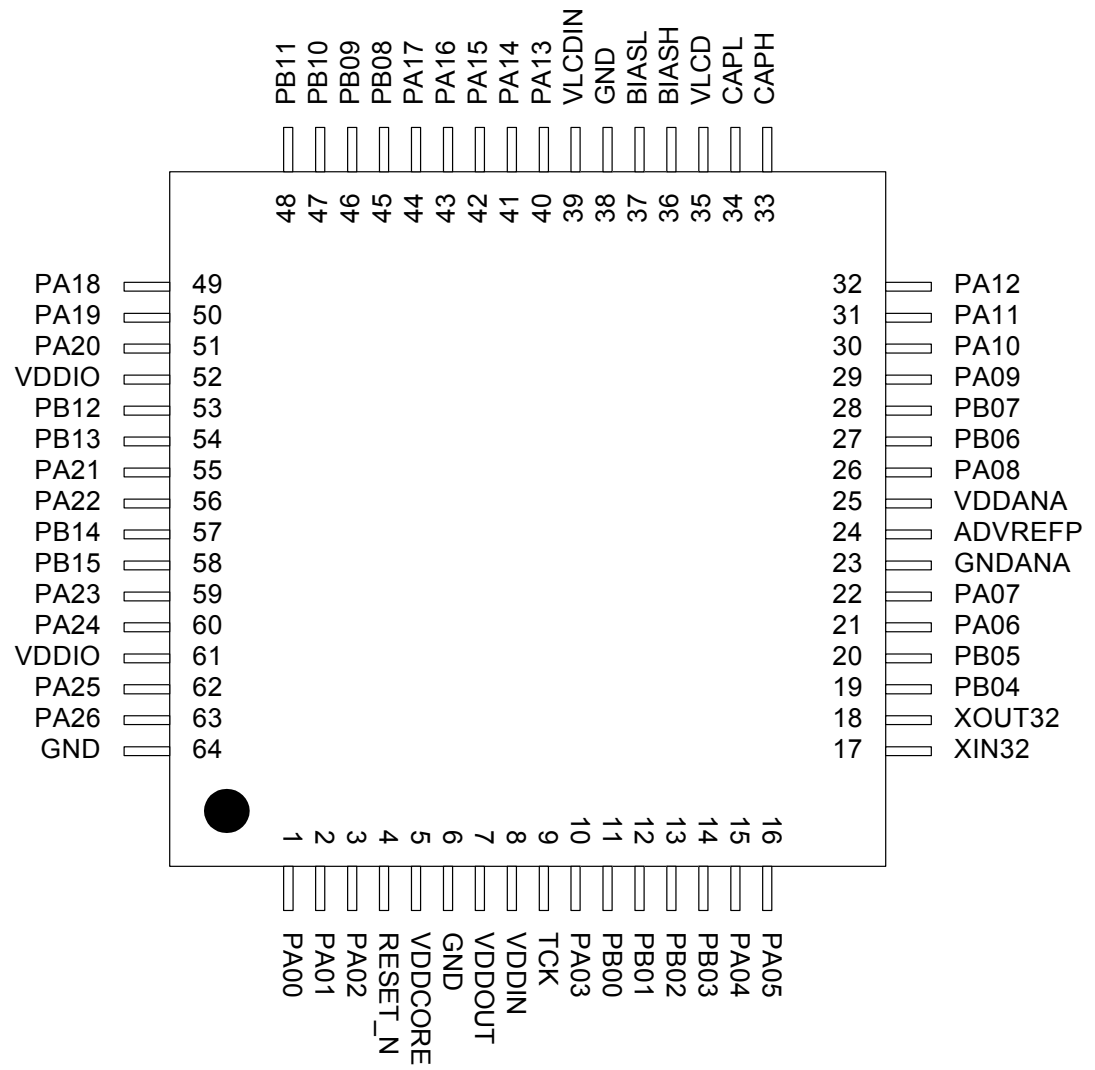
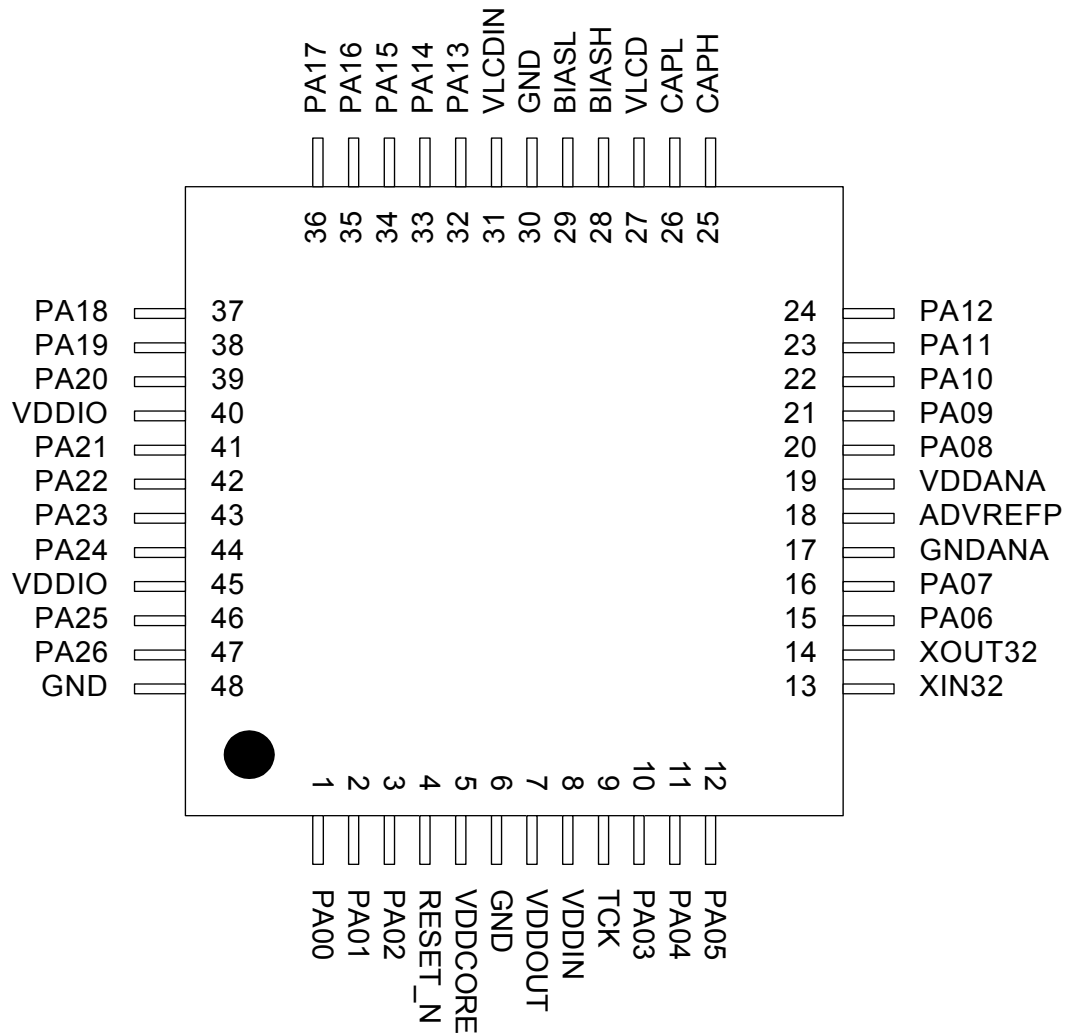

Figure 3-5. ATSAM4LC TQFP48/QFN48 Pinout



3.1.2 ATSAM4LSx Pinout

Figure 3-6. ATSAM4LS TQFP100 Pinout

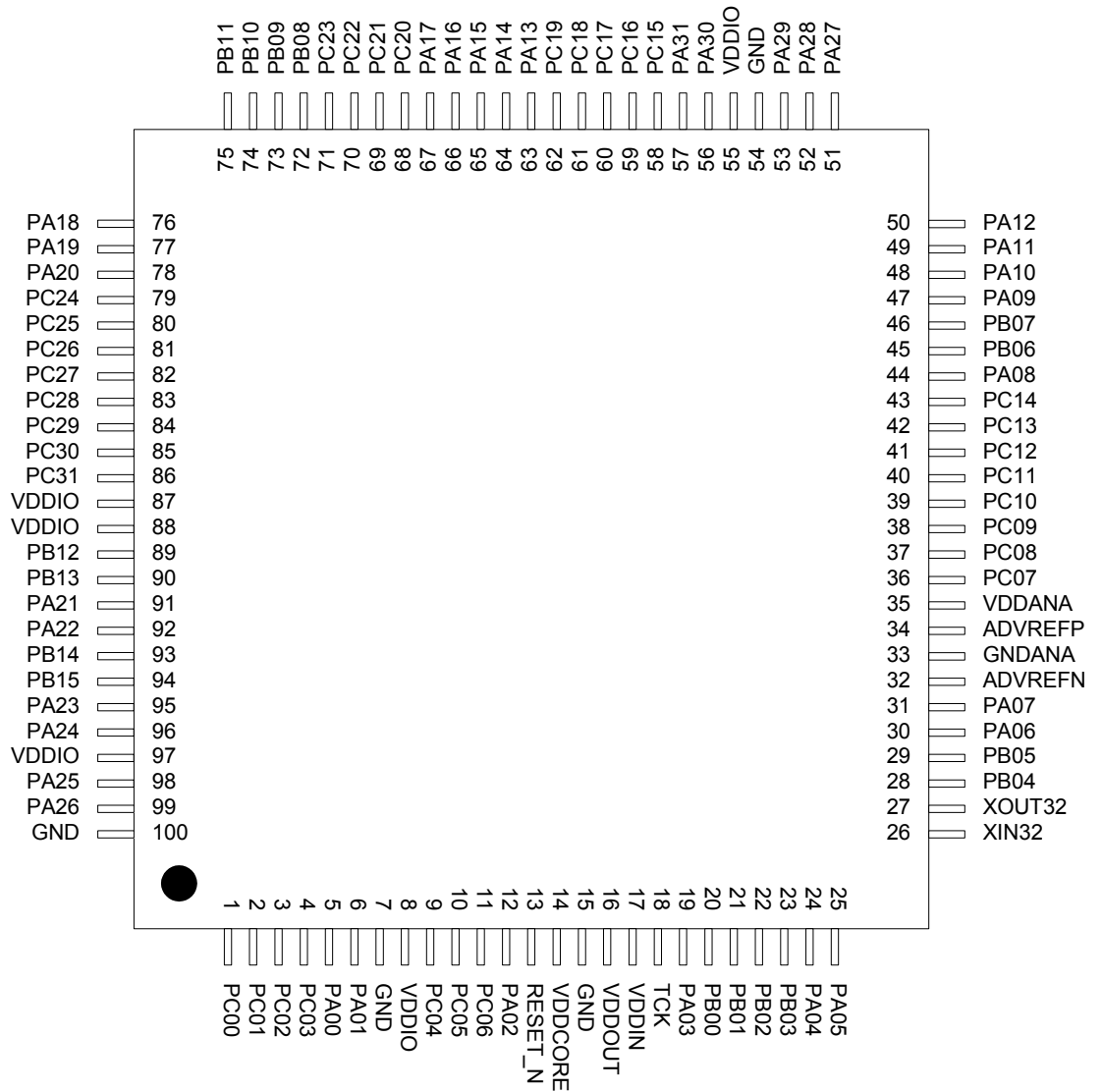

Figure 3-7. ATSAM4LS VFBGA100 Pinout

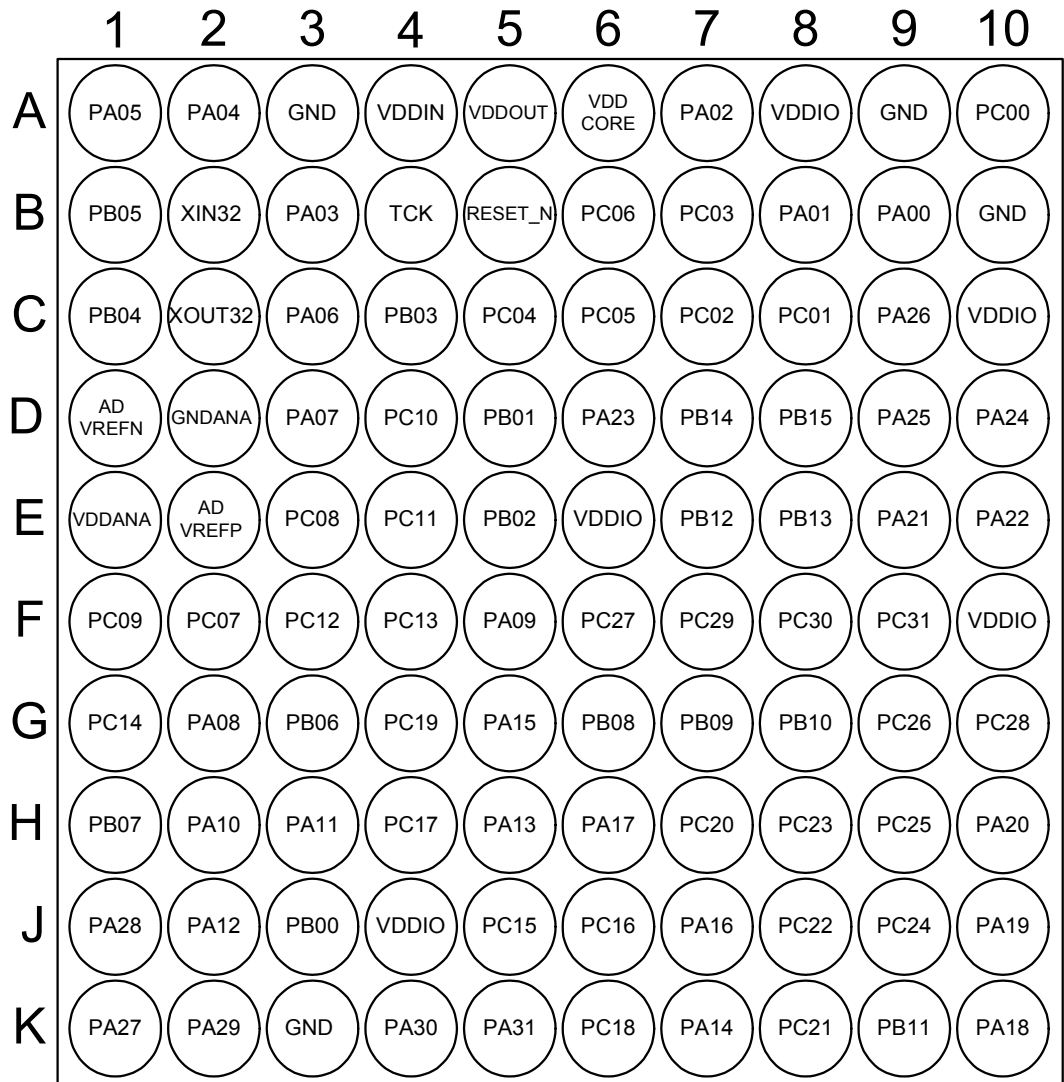

Figure 3-8. ATSAM4LS WLCSP64 Pinout

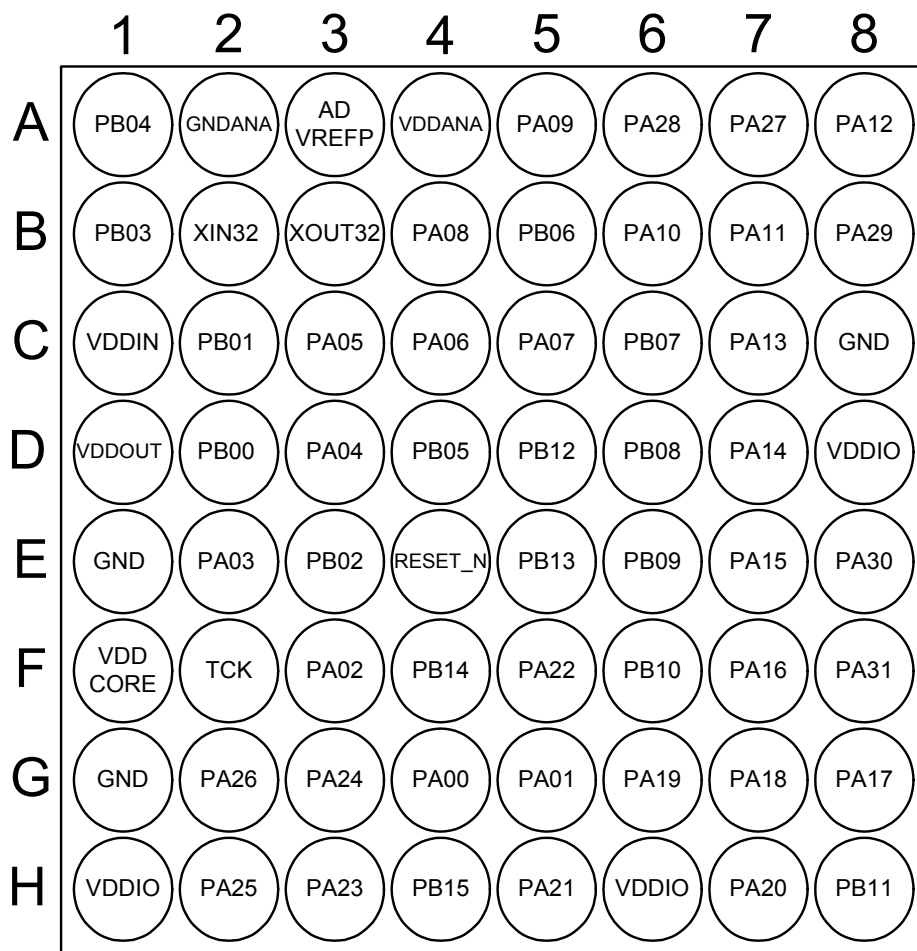

Figure 3-9. ATSAM4LS TQFP64/QFN64 Pinout

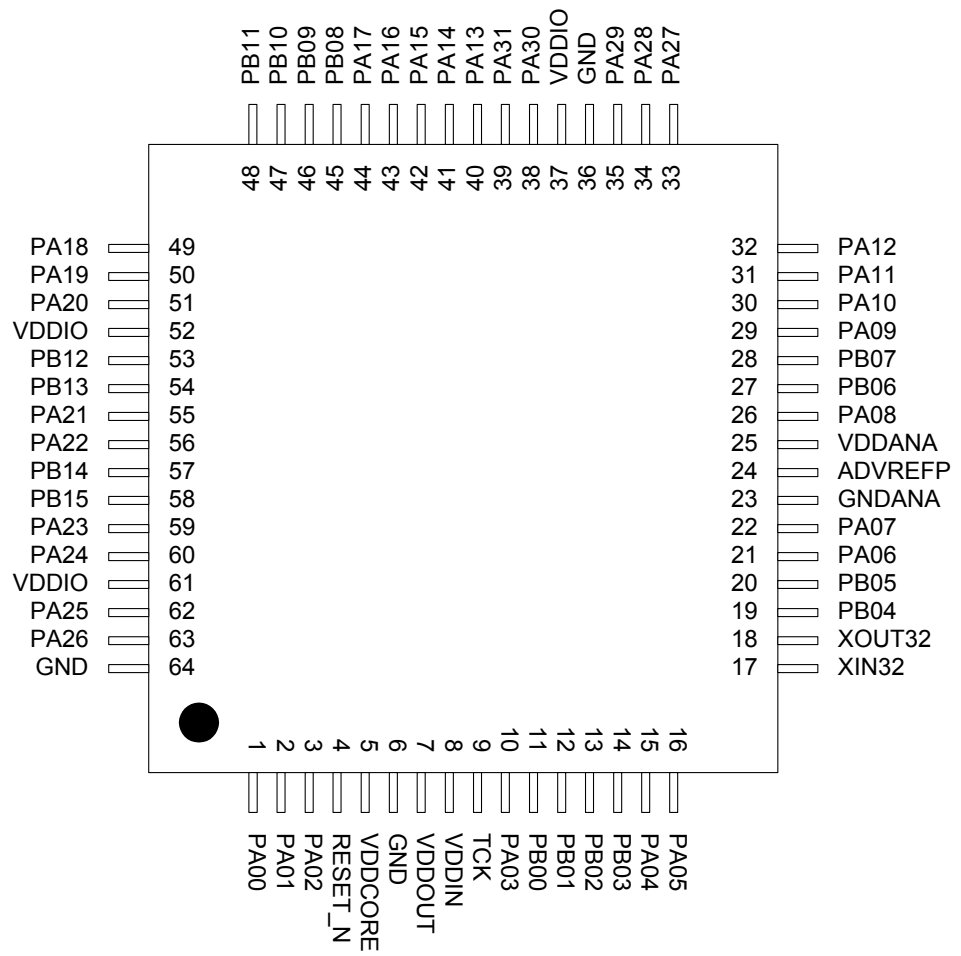
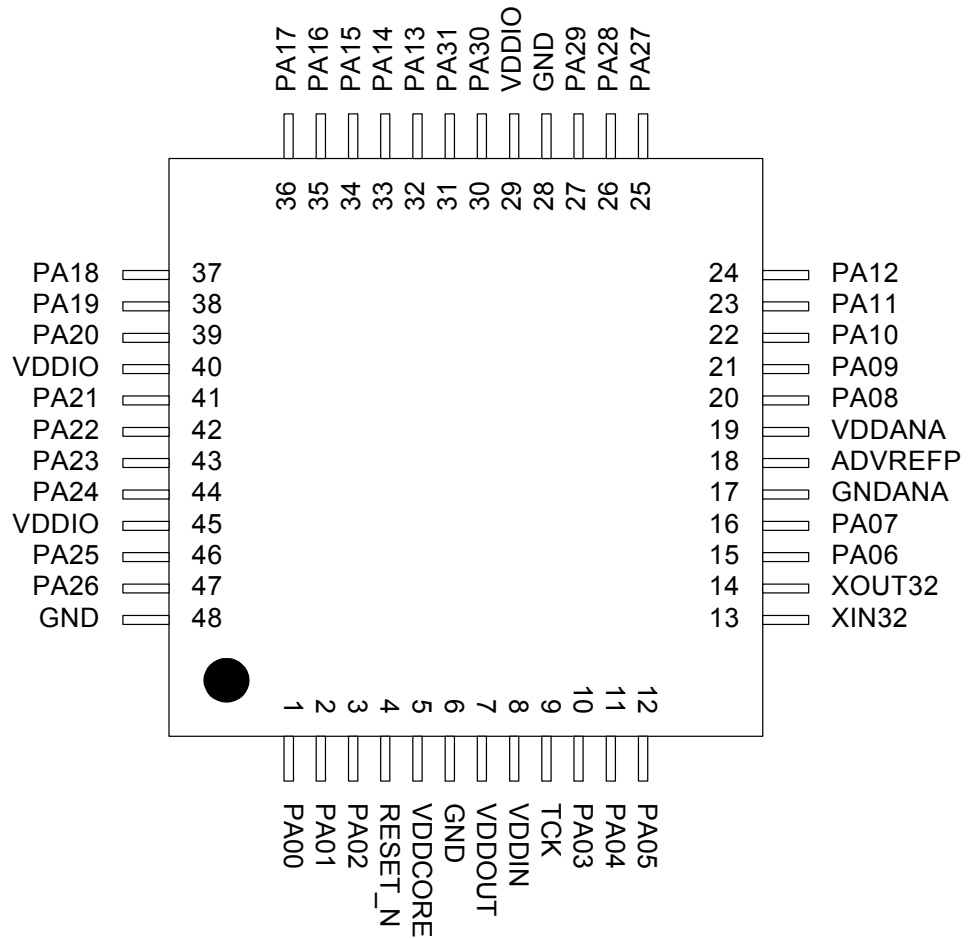

Figure 3-10. ATSAM4LS TQFP48/QFN48 Pinout



See [Section 3.3 "Signals Description" on page 30](#) for a description of the various peripheral signals.

Refer to ["Electrical Characteristics" on page 98](#) for a description of the electrical properties of the pin types used.

3.2 Peripheral Multiplexing on I/O lines

3.2.1 Multiplexed Signals

Each GPIO line can be assigned to one of the peripheral functions. The following tables ([Section 3-1 "100-pin GPIO Controller Function Multiplexing" on page 18](#) to [Section 3-4 "48-pin GPIO Controller Function Multiplexing" on page 27](#)) describes the peripheral signals multiplexed to the GPIO lines.

Peripheral functions that are not relevant in some parts of the family are grey-shaded.

For description of different Supply voltage source, refer to the [Section 6. "Power and Startup Considerations" on page 45](#).

Table 3-1. 100-pin GPIO Controller Function Multiplexing (Sheet 1 of 4)

ATSAM4LC		ATSAM4LS		Pin	GPIO	Supply	GPIO Functions								
QFN	VFBGA	QFN	VFBGA				A	B	C	D	E	F	G		
5	B9	5	B9	PA00	0	VDDIO									
6	B8	6	B8	PA01	1	VDDIO									
12	A7	12	A7	PA02	2	VDDIN	SCIF GCLK0	SPI NPCS0							CATB DIS
19	B3	19	B3	PA03	3	VDDIN		SPI MISO							
24	A2	24	A2	PA04	4	VDDANA	ADCIFE AD0	USART0 CLK	EIC EXTINT2	GLOC IN1					CATB SENSE0
25	A1	25	A1	PA05	5	VDDANA	ADCIFE AD1	USART0 RXD	EIC EXTINT3	GLOC IN2	ADCIFE TRIGGER				CATB SENSE1
30	C3	30	C3	PA06	6	VDDANA	DACC VOUT	USART0 RTS	EIC EXTINT1	GLOC IN0	ACIFC ACAN0				CATB SENSE2
31	D3	31	D3	PA07	7	VDDANA	ADCIFE AD2	USART0 TXD	EIC EXTINT4	GLOC IN3	ACIFC ACAP0				CATB SENSE3
44	G2	44	G2	PA08	8	LCDA	USART0 RTS	TC0 A0	PEVC PAD EVT0	GLOC OUT0			LCDCA SEG23		CATB SENSE4
47	F5	47	F5	PA09	9	LCDA	USART0 CTS	TC0 B0	PEVC PAD EVT1	PARC PCDATA0			LCDCA COM3		CATB SENSE5
48	H2	48	H2	PA10	10	LCDA	USART0 CLK	TC0 A1	PEVC PAD EVT2	PARC PCDATA1			LCDCA COM2		CATB SENSE6
49	H3	49	H3	PA11	11	LCDA	USART0 RXD	TC0 B1	PEVC PAD EVT3	PARC PCDATA2			LCDCA COM1		CATB SENSE7
50	J2	50	J2	PA12	12	LCDA	USART0 TXD	TC0 A2		PARC PCDATA3			LCDCA COM0		CATB DIS
63	H5	63	H5	PA13	13	LCDA	USART1 RTS	TC0 B2	SPI NPCS1	PARC PCDATA4			LCDCA SEG5		CATB SENSE8
64	K7	64	K7	PA14	14	LCDA	USART1 CLK	TC0 CLK0	SPI NPCS2	PARC PCDATA5			LCDCA SEG6		CATB SENSE9
65	G5	65	G5	PA15	15	LCDA	USART1 RXD	TC0 CLK1	SPI NPCS3	PARC PCDATA6			LCDCA SEG7		CATB SENSE10

Table 3-1. 100-pin GPIO Controller Function Multiplexing (Sheet 2 of 4)

ATSAM4LC		ATSAM4LS		Pin	GPIO	Supply	GPIO Functions						
QFN	VFBGA	QFN	VFBGA				A	B	C	D	E	F	G
66	J7	66	J7	PA16	16	LCDA	USART1 TXD	TC0 CLK2	EIC EXTINT1	PARC PCDATA7		LCDCA SEG8	CATB SENSE11
67	H6	67	H6	PA17	17	LCDA	USART2 RTS	ABDACB DAC0	EIC EXTINT2	PARC PCK		LCDCA SEG9	CATB SENSE12
76	K10	76	K10	PA18	18	LCDA	USART2 CLK	ABDACB DACN0	EIC EXTINT3	PARC PCEN1		LCDCA SEG18	CATB SENSE13
77	J10	77	J10	PA19	19	LCDA	USART2 RXD	ABDACB DAC1	EIC EXTINT4	PARC PCEN2	SCIF GCLK0	LCDCA SEG19	CATB SENSE14
78	H10	78	H10	PA20	20	LCDA	USART2 TXD	ABDACB DACN1	EIC EXTINT5	GLOC IN0	SCIF GCLK1	LCDCA SEG20	CATB SENSE15
91	E9	91	E9	PA21	21	LCDC	SPI MISO	USART1 CTS	EIC EXTINT6	GLOC IN1	TWIM2 TWD	LCDCA SEG34	CATB SENSE16
92	E10	92	E10	PA22	22	LCDC	SPI MOSI	USART2 CTS	EIC EXTINT7	GLOC IN2	TWIM2 TWCK	LCDCA SEG35	CATB SENSE17
95	D6	95	D6	PA23	23	LCDC	SPI SCK	TWIMS0 TWD	EIC EXTINT8	GLOC IN3	SCIF GCLK IN0	LCDCA SEG38	CATB DIS
96	D10	96	D10	PA24	24	LCDC	SPI NPCS0	TWIMS0 TWCK		GLOC OUT0	SCIF GCLK IN1	LCDCA SEG39	CATB SENSE18
98	D9	98	D9	PA25	25	VDDIO	USBC DM	USART2 RXD					CATB SENSE19
99	C9	99	C9	PA26	26	VDDIO	USBC DP	USART2 TXD					CATB SENSE20
		51	K1	PA27	27	LCDA	SPI MISO	IISC ISCK	ABDACB DAC0	GLOC IN4	USART3 RTS		CATB SENSE0
		52	J1	PA28	28	LCDA	SPI MOSI	IISC ISDI	ABDACB DACN0	GLOC IN5	USART3 CTS		CATB SENSE1
		53	K2	PA29	29	LCDA	SPI SCK	IISC IWS	ABDACB DAC1	GLOC IN6	USART3 CLK		CATB SENSE2
		56	K4	PA30	30	LCDA	SPI NPCS0	IISC ISDO	ABDACB DACN1	GLOC IN7	USART3 RXD		CATB SENSE3
		57	K5	PA31	31	LCDA	SPI NPCS1	IISC IMCK	ABDACB CLK	GLOC OUT1	USART3 TXD		CATB DIS
20	J3	20	J3	PB00	32	VDDIN	TWIMS1 TWD	USART0 RXD					CATB SENSE21
21	D5	21	D5	PB01	33	VDDIN	TWIMS1 TWCK	USART0 TXD	EIC EXTINT0				CATB SENSE22
22	E5	22	E5	PB02	34	VDDANA	ADCIFE AD3	USART1 RTS	ABDACB DAC0	IISC ISCK	ACIFC ACBN0		CATB SENSE23
23	C4	23	C4	PB03	35	VDDANA	ADCIFE AD4	USART1 CLK	ABDACB DACN0	IISC ISDI	ACIFC ACBP0		CATB DIS
28	C1	28	C1	PB04	36	VDDANA	ADCIFE AD5	USART1 RXD	ABDACB DAC1	IISC ISDO	DACC EXT TRIG0		CATB SENSE24
29	B1	29	B1	PB05	37	VDDANA	ADCIFE AD6	USART1 TXD	ABDACB DACN1	IISC IMCK			CATB SENSE25
45	G3	45	G3	PB06	38	LCDA	USART3 RTS		GLOC IN4	IISC IWS		LCDCA SEG22	CATB SENSE26
46	H1	46	H1	PB07	39	LCDA	USART3 CTS		GLOC IN5	TC0 A0		LCDCA SEG21	CATB SENSE27

Table 3-1. 100-pin GPIO Controller Function Multiplexing (Sheet 3 of 4)

ATSAM4LC		ATSAM4LS		Pin	GPIO	Supply	GPIO Functions						
QFN	VFBGA	QFN	VFBGA				A	B	C	D	E	F	G
72	G6	72	G6	PB08	40	LCDA	USART3 CLK		GLOC IN6	TC0 B0		LCDCA SEG14	CATB SENSE28
73	G7	73	G7	PB09	41	LCDA	USART3 RXD	PEVC PAD EVT2	GLOC IN7	TC0 A1		LCDCA SEG15	CATB SENSE29
74	G8	74	G8	PB10	42	LCDA	USART3 TXD	PEVC PAD EVT3	GLOC OUT1	TC0 B1	SCIF GCLK0	LCDCA SEG16	CATB SENSE30
75	K9	75	K9	PB11	43	LCDA	USART0 CTS	SPI NPCS2		TC0 A2	SCIF GCLK1	LCDCA SEG17	CATB SENSE31
89	E7	89	E7	PB12	44	LCDC	USART0 RTS	SPI NPCS3	PEVC PAD EVT0	TC0 B2	SCIF GCLK2	LCDCA SEG32	CATB DIS
90	E8	90	E8	PB13	45	LCDC	USART0 CLK	SPI NPCS1	PEVC PAD EVT1	TC0 CLK0	SCIF GCLK3	LCDCA SEG33	CATB SENSE0
93	D7	93	D7	PB14	46	LCDC	USART0 RXD	SPI MISO	TWIM3 TWD	TC0 CLK1	SCIF GCLK IN0	LCDCA SEG36	CATB SENSE1
94	D8	94	D8	PB15	47	LCDC	USART0 TXD	SPI MOSI	TWIM3 TWCK	TC0 CLK2	SCIF GCLK IN1	LCDCA SEG37	CATB SENSE2
1	A10	1	A10	PC00	64	VDDIO	SPI NPCS2	USART0 CLK		TC1 A0			CATB SENSE3
2	C8	2	C8	PC01	65	VDDIO	SPI NPCS3	USART0 RTS		TC1 B0			CATB SENSE4
3	C7	3	C7	PC02	66	VDDIO	SPI NPCS1	USART0 CTS	USART0 RXD	TC1 A1			CATB SENSE5
4	B7	4	B7	PC03	67	VDDIO	SPI NPCS0	EIC EXTINT5	USART0 TXD	TC1 B1			CATB SENSE6
9	C5	9	C5	PC04	68	VDDIO	SPI MISO	EIC EXTINT6		TC1 A2			CATB SENSE7
10	C6	10	C6	PC05	69	VDDIO	SPI MOSI	EIC EXTINT7		TC1 B2			CATB DIS
11	B6	11	B6	PC06	70	VDDIO	SPI SCK	EIC EXTINT8		TC1 CLK0			CATB SENSE8
36	F2	36	F2	PC07	71	VDDANA	ADCIFE AD7	USART2 RTS	PEVC PAD EVT0	TC1 CLK1			CATB SENSE9
37	E3	37	E3	PC08	72	VDDANA	ADCIFE AD8	USART2 CLK	PEVC PAD EVT1	TC1 CLK2	USART2 CTS		CATB SENSE10
38	F1	38	F1	PC09	73	VDDANA	ADCIFE AD9	USART3 RXD	ABDACB DAC0	IISC ISCK	ACIFC ACAN1		CATB SENSE11
39	D4	39	D4	PC10	74	VDDANA	ADCIFE AD10	USART3 TXD	ABDACB DACN0	IISC ISDI	ACIFC ACAP1		CATB SENSE12
40	E4	40	E4	PC11	75	VDDANA	ADCIFE AD11	USART2 RXD	PEVC PAD EVT2				CATB SENSE13
41	F3	41	F3	PC12	76	VDDANA	ADCIFE AD12	USART2 TXD	ABDACB CLK	IISC IWS			CATB SENSE14
42	F4	42	F4	PC13	77	VDDANA	ADCIFE AD13	USART3 RTS	ABDACB DAC1	IISC ISDO	ACIFC ACBN1		CATB SENSE15
43	G1	43	G1	PC14	78	VDDANA	ADCIFE AD14	USART3 CLK	ABDACB DACN1	IISC IMCK	ACIFC ACBP1		CATB DIS
58	J5	58	J5	PC15	79	LCDA	TC1 A0			GLOC IN4		LCDCA SEG0	CATB SENSE16

Table 3-1. 100-pin GPIO Controller Function Multiplexing (Sheet 4 of 4)

ATSAM4LC		ATSAM4LS		Pin	GPIO	Supply	GPIO Functions						
QFN	VFBGA	QFN	VFBGA				A	B	C	D	E	F	G
59	J6	59	J6	PC16	80	LCDA	TC1 B0			GLOC IN5		LCDCA SEG1	CATB SENSE17
60	H4	60	H4	PC17	81	LCDA	TC1 A1			GLOC IN6		LCDCA SEG2	CATB SENSE18
61	K6	61	K6	PC18	82	LCDA	TC1 B1			GLOC IN7		LCDCA SEG3	CATB SENSE19
62	G4	62	G4	PC19	83	LCDA	TC1 A2			GLOC OUT1		LCDCA SEG4	CATB SENSE20
68	H7	68	H7	PC20	84	LCDA	TC1 B2					LCDCA SEG10	CATB SENSE21
69	K8	69	K8	PC21	85	LCDA	TC1 CLK0			PARC PCCK		LCDCA SEG11	CATB SENSE22
70	J8	70	J8	PC22	86	LCDA	TC1 CLK1			PARC PCEN1		LCDCA SEG12	CATB SENSE23
71	H8	71	H8	PC23	87	LCDA	TC1 CLK2			PARC PCEN2		LCDCA SEG13	CATB DIS
79	J9	79	J9	PC24	88	LCDB	USART1 RTS	EIC EXTINT1	PEVC PAD EVT0	PARC PCDATA0		LCDCA SEG24	CATB SENSE24
80	H9	80	H9	PC25	89	LCDB	USART1 CLK	EIC EXTINT2	PEVC PAD EVT1	PARC PCDATA1		LCDCA SEG25	CATB SENSE25
81	G9	81	G9	PC26	90	LCDB	USART1 RXD	EIC EXTINT3	PEVC PAD EVT2	PARC PCDATA2	SCIF GCLK0	LCDCA SEG26	CATB SENSE26
82	F6	82	F6	PC27	91	LCDB	USART1 TXD	EIC EXTINT4	PEVC PAD EVT3	PARC PCDATA3	SCIF GCLK1	LCDCA SEG27	CATB SENSE27
83	G10	83	G10	PC28	92	LCDB	USART3 RXD	SPI MISO	GLOC IN4	PARC PCDATA4	SCIF GCLK2	LCDCA SEG28	CATB SENSE28
84	F7	84	F7	PC29	93	LCDB	USART3 TXD	SPI MOSI	GLOC IN5	PARC PCDATA5	SCIF GCLK3	LCDCA SEG29	CATB SENSE29
85	F8	85	F8	PC30	94	LCDB	USART3 RTS	SPI SCK	GLOC IN6	PARC PCDATA6	SCIF GCLK IN0	LCDCA SEG30	CATB SENSE30
86	F9	86	F9	PC31	95	LCDB	USART3 CLK	SPI NPCS0	GLOC OUT1	PARC PCDATA7	SCIF GCLK IN1	LCDCA SEG31	CATB SENSE31

Table 3-2. 64-pin GPIO Controller Function Multiplexing (Sheet 1 of 3)

ATSAM4LC		ATSAM4LS		Pin	GPIO	Supply	GPIO Functions						
QFP	QFN	QFP	QFN				A	B	C	D	E	F	G
1	1	1	1	PA00	0	VDDIO							
2	2	2	2	PA01	1	VDDIO							
3	3	3	3	PA02	2	VDDIN	SCIF GCLK0	SPI NPCS0					CATB DIS
10	10	10	10	PA03	3	VDDIN		SPI MISO					

Table 3-2. 64-pin GPIO Controller Function Multiplexing (Sheet 2 of 3)

ATSAM4LC	ATSAM4LS	Pin	GPIO	Supply	GPIO Functions							
					A	B	C	D	E	F	G	
QFP QFN	QFP QFN											
15	15	PA04	4	VDDANA	ADCIFE AD0	USART0 CLK	EIC EXTINT2	GLOC IN1				CATB SENSE0
16	16	PA05	5	VDDANA	ADCIFE AD1	USART0 RXD	EIC EXTINT3	GLOC IN2	ADCIFE TRIGGER			CATB SENSE1
21	21	PA06	6	VDDANA	DACC VOUT	USART0 RTS	EIC EXTINT1	GLOC IN0	ACIFC ACAN0			CATB SENSE2
22	22	PA07	7	VDDANA	ADCIFE AD2	USART0 TXD	EIC EXTINT4	GLOC IN3	ACIFC ACAP0			CATB SENSE3
26	26	PA08	8	LCDA	USART0 RTS	TC0 A0	PEVC PAD EVT0	GLOC OUT0		LCDC SEG23		CATB SENSE4
29	29	PA09	9	LCDA	USART0 CTS	TC0 B0	PEVC PAD EVT1	PARC PCDATA0		LCDC COM3		CATB SENSE5
30	30	PA10	10	LCDA	USART0 CLK	TC0 A1	PEVC PAD EVT2	PARC PCDATA1		LCDC COM2		CATB SENSE6
31	31	PA11	11	LCDA	USART0 RXD	TC0 B1	PEVC PAD EVT3	PARC PCDATA2		LCDC COM1		CATB SENSE7
32	32	PA12	12	LCDA	USART0 TXD	TC0 A2		PARC PCDATA3		LCDC COM0		CATB DIS
40	40	PA13	13	LCDA	USART1 RTS	TC0 B2	SPI NPCS1	PARC PCDATA4		LCDC SEG5		CATB SENSE8
41	41	PA14	14	LCDA	USART1 CLK	TC0 CLK0	SPI NPCS2	PARC PCDATA5		LCDC SEG6		CATB SENSE9
42	42	PA15	15	LCDA	USART1 RXD	TC0 CLK1	SPI NPCS3	PARC PCDATA6		LCDC SEG7		CATB SENSE10
43	43	PA16	16	LCDA	USART1 TXD	TC0 CLK2	EIC EXTINT1	PARC PCDATA7		LCDC SEG8		CATB SENSE11
44	44	PA17	17	LCDA	USART2 RTS	ABDACB DAC0	EIC EXTINT2	PARC PCCK		LCDC SEG9		CATB SENSE12
49	49	PA18	18	LCDA	USART2 CLK	ABDACB DACN0	EIC EXTINT3	PARC PCEN1		LCDC SEG18		CATB SENSE13
50	50	PA19	19	LCDA	USART2 RXD	ABDACB DAC1	EIC EXTINT4	PARC PCEN2	SCIF GCLK0	LCDC SEG19		CATB SENSE14
51	51	PA20	20	LCDA	USART2 TXD	ABDACB DACN1	EIC EXTINT5	GLOC IN0	SCIF GCLK1	LCDC SEG20		CATB SENSE15
55	55	PA21	21	LCDC	SPI MISO	USART1 CTS	EIC EXTINT6	GLOC IN1	TWIM2 TWD	LCDC SEG34		CATB SENSE16
56	56	PA22	22	LCDC	SPI MOSI	USART2 CTS	EIC EXTINT7	GLOC IN2	TWIM2 TWCK	LCDC SEG35		CATB SENSE17
59	59	PA23	23	LCDC	SPI SCK	TWIMS0 TWD	EIC EXTINT8	GLOC IN3	SCIF GCLK IN0	LCDC SEG38		CATB DIS
60	60	PA24	24	LCDC	SPI NPCS0	TWIMS0 TWCK		GLOC OUT0	SCIF GCLK IN1	LCDC SEG39		CATB SENSE18
62	62	PA25	25	VDDIO	USBC DM	USART2 RXD						CATB SENSE19
63	63	PA26	26	VDDIO	USBC DP	USART2 TXD						CATB SENSE20

Table 3-2. 64-pin GPIO Controller Function Multiplexing (Sheet 3 of 3)

QFP QFN	QFP QFN	Pin	GPIO	Supply	GPIO Functions						
					A	B	C	D	E	F	G
	33	PA27	27	LCDA	SPI MISO	IISC ISCK	ABDACB DAC0	GLOC IN4	USART3 RTS		CATB SENSE0
	34	PA28	28	LCDA	SPI MOSI	IISC ISDI	ABDACB DACN0	GLOC IN5	USART3 CTS		CATB SENSE1
	35	PA29	29	LCDA	SPI SCK	IISC IWS	ABDACB DAC1	GLOC IN6	USART3 CLK		CATB SENSE2
	38	PA30	30	LCDA	SPI NPCS0	IISC ISDO	ABDACB DACN1	GLOC IN7	USART3 RXD		CATB SENSE3
	39	PA31	31	LCDA	SPI NPCS1	IISC IMCK	ABDACB CLK	GLOC OUT1	USART3 TXD		CATB DIS
11	11	PB00	32	VDDIN	TWIMS1 TWD	USART0 RXD					CATB SENSE21
12	12	PB01	33	VDDIN	TWIMS1 TWCK	USART0 TXD	EIC EXTINT0				CATB SENSE22
13	13	PB02	34	VDDANA	ADCIFE AD3	USART1 RTS	ABDACB DAC0	IISC ISCK	ACIFC ACBN0		CATB SENSE23
14	14	PB03	35	VDDANA	ADCIFE AD4	USART1 CLK	ABDACB DACN0	IISC ISDI	ACIFC ACBP0		CATB DIS
19	19	PB04	36	VDDANA	ADCIFE AD5	USART1 RXD	ABDACB DAC1	IISC ISDO	DACC EXT TRIG0		CATB SENSE24
20	20	PB05	37	VDDANA	ADCIFE AD6	USART1 TXD	ABDACB DACN1	IISC IMCK			CATB SENSE25
27	27	PB06	38	LCDA	USART3 RTS		GLOC IN4	IISC IWS		LCDCA SEG22	CATB SENSE26
28	28	PB07	39	LCDA	USART3 CTS		GLOC IN5	TC0 A0		LCDCA SEG21	CATB SENSE27
45	45	PB08	40	LCDA	USART3 CLK		GLOC IN6	TC0 B0		LCDCA SEG14	CATB SENSE28
46	46	PB09	41	LCDA	USART3 RXD	PEVC PAD EVT2	GLOC IN7	TC0 A1		LCDCA SEG15	CATB SENSE29
47	47	PB10	42	LCDA	USART3 TXD	PEVC PAD EVT3	GLOC OUT1	TC0 B1	SCIF GCLK0	LCDCA SEG16	CATB SENSE30
48	48	PB11	43	LCDA	USART0 CTS	SPI NPCS2		TC0 A2	SCIF GCLK1	LCDCA SEG17	CATB SENSE31
53	53	PB12	44	LCDC	USART0 RTS	SPI NPCS3	PEVC PAD EVT0	TC0 B2	SCIF GCLK2	LCDCA SEG32	CATB DIS
54	54	PB13	45	LCDC	USART0 CLK	SPI NPCS1	PEVC PAD EVT1	TC0 CLK0	SCIF GCLK3	LCDCA SEG33	CATB SENSE0
57	57	PB14	46	LCDC	USART0 RXD	SPI MISO	TWIM3 TWD	TC0 CLK1	SCIF GCLK IN0	LCDCA SEG36	CATB SENSE1
58	58	PB15	47	LCDC	USART0 TXD	SPI MOSI	TWIM3 TWCK	TC0 CLK2	SCIF GCLK IN1	LCDCA SEG37	CATB SENSE2

Table 3-3. 64-pin GPIO Controller Function Multiplexing for WLCSP package (Sheet 1 of 3)

WLCSP	WLCSP	Pin	GPIO	Supply	GPIO Functions							
					A	B	C	D	E	F	G	
G4	G4	PA00	0	VDDIO								
G5	G5	PA01	1	VDDIO								
F3	F3	PA02	2	VDDIN	SCIF GCLK0	SPI NPCS0						CATB DIS
E2	E2	PA03	3	VDDIN		SPI MISO						
D3	D3	PA04	4	VDDANA	ADCIFE AD0	USART0 CLK	EIC EXTINT2	GLOC IN1				CATB SENSE0
C3	C3	PA05	5	VDDANA	ADCIFE AD1	USART0 RXD	EIC EXTINT3	GLOC IN2	ADCIFE TRIGGER			CATB SENSE1
C4	C4	PA06	6	VDDANA	DACC VOUT	USART0 RTS	EIC EXTINT1	GLOC IN0	ACIFC ACAN0			CATB SENSE2
C5	C5	PA07	7	VDDANA	ADCIFE AD2	USART0 TXD	EIC EXTINT4	GLOC IN3	ACIFC ACAP0			CATB SENSE3
B4	B4	PA08	8	LCDA	USART0 RTS	TC0 A0	PEVC PAD EVT0	GLOC OUT0		LCDCA SEG23		CATB SENSE4
A5	A5	PA09	9	LCDA	USART0 CTS	TC0 B0	PEVC PAD EVT1	PARC PCDATA0		LCDCA COM3		CATB SENSE5
B6	B6	PA10	10	LCDA	USART0 CLK	TC0 A1	PEVC PAD EVT2	PARC PCDATA1		LCDCA COM2		CATB SENSE6
B7	B7	PA11	11	LCDA	USART0 RXD	TC0 B1	PEVC PAD EVT3	PARC PCDATA2		LCDCA COM1		CATB SENSE7
A8	A8	PA12	12	LCDA	USART0 TXD	TC0 A2		PARC PCDATA3		LCDCA COM0		CATB DIS
C7	C7	PA13	13	LCDA	USART1 RTS	TC0 B2	SPI NPCS1	PARC PCDATA4		LCDCA SEG5		CATB SENSE8
D7	D7	PA14	14	LCDA	USART1 CLK	TC0 CLK0	SPI NPCS2	PARC PCDATA5		LCDCA SEG6		CATB SENSE9
E7	E7	PA15	15	LCDA	USART1 RXD	TC0 CLK1	SPI NPCS3	PARC PCDATA6		LCDCA SEG7		CATB SENSE10
F7	F7	PA16	16	LCDA	USART1 TXD	TC0 CLK2	EIC EXTINT1	PARC PCDATA7		LCDCA SEG8		CATB SENSE11
G8	G8	PA17	17	LCDA	USART2 RTS	ABDACB DAC0	EIC EXTINT2	PARC PCCK		LCDCA SEG9		CATB SENSE12
G7	G7	PA18	18	LCDA	USART2 CLK	ABDACB DACN0	EIC EXTINT3	PARC PCEN1		LCDCA SEG18		CATB SENSE13
G6	G6	PA19	19	LCDA	USART2 RXD	ABDACB DAC1	EIC EXTINT4	PARC PCEN2	SCIF GCLK0	LCDCA SEG19		CATB SENSE14
H7	H7	PA20	20	LCDA	USART2 TXD	ABDACB DACN1	EIC EXTINT5	GLOC IN0	SCIF GCLK1	LCDCA SEG20		CATB SENSE15
H5	H5	PA21	21	LCDC	SPI MISO	USART1 CTS	EIC EXTINT6	GLOC IN1	TWIM2 TWD	LCDCA SEG34		CATB SENSE16
F5	F5	PA22	22	LCDC	SPI MOSI	USART2 CTS	EIC EXTINT7	GLOC IN2	TWIM2 TWCK	LCDCA SEG35		CATB SENSE17

Table 3-3. 64-pin GPIO Controller Function Multiplexing for WLCSP package (Sheet 2 of 3)

WLCSP	WLCSP	Pin	GPIO	Supply	GPIO Functions						
					A	B	C	D	E	F	G
H3	H3	PA23	23	LCDC	SPI SCK	TWIMS0 TWD	EIC EXTINT8	GLOC IN3	SCIF GCLK IN0	LCDCA SEG38	CATB DIS
G3	G3	PA24	24	LCDC	SPI NPCS0	TWIMS0 TWCK		GLOC OUT0	SCIF GCLK IN1	LCDCA SEG39	CATB SENSE18
H2	H2	PA25	25	VDDIO	USBC DM	USART2 RXD					CATB SENSE19
G2	G2	PA26	26	VDDIO	USBC DP	USART2 TXD					CATB SENSE20
	A7	PA27	27	LCDA	SPI MISO	IISC ISCK	ABDACB DAC0	GLOC IN4	USART3 RTS		CATB SENSE0
	A6	PA28	28	LCDA	SPI MOSI	IISC ISDI	ABDACB DACN0	GLOC IN5	USART3 CTS		CATB SENSE1
	B8	PA29	29	LCDA	SPI SCK	IISC IWS	ABDACB DAC1	GLOC IN6	USART3 CLK		CATB SENSE2
	E8	PA30	30	LCDA	SPI NPCS0	IISC ISDO	ABDACB DACN1	GLOC IN7	USART3 RXD		CATB SENSE3
	F8	PA31	31	LCDA	SPI NPCS1	IISC IMCK	ABDACB CLK	GLOC OUT1	USART3 TXD		CATB DIS
D2	D2	PB00	32	VDDIN	TWIMS1 TWD	USART0 RXD					CATB SENSE21
C2	C2	PB01	33	VDDIN	TWIMS1 TWCK	USART0 TXD	EIC EXTINT0				CATB SENSE22
E3	E3	PB02	34	VDDANA	ADCIFE AD3	USART1 RTS	ABDACB DAC0	IISC ISCK	ACIFC ACBN0		CATB SENSE23
B1	B1	PB03	35	VDDANA	ADCIFE AD4	USART1 CLK	ABDACB DACN0	IISC ISDI	ACIFC ACBP0		CATB DIS
A1	A1	PB04	36	VDDANA	ADCIFE AD5	USART1 RXD	ABDACB DAC1	IISC ISDO	DACC EXT TRIG0		CATB SENSE24
D4	D4	PB05	37	VDDANA	ADCIFE AD6	USART1 TXD	ABDACB DACN1	IISC IMCK			CATB SENSE25
B5	B5	PB06	38	LCDA	USART3 RTS		GLOC IN4	IISC IWS		LCDCA SEG22	CATB SENSE26
C6	C6	PB07	39	LCDA	USART3 CTS		GLOC IN5	TC0 A0		LCDCA SEG21	CATB SENSE27
D6	D6	PB08	40	LCDA	USART3 CLK		GLOC IN6	TC0 B0		LCDCA SEG14	CATB SENSE28
E6	E6	PB09	41	LCDA	USART3 RXD	PEVC PAD EVT2	GLOC IN7	TC0 A1		LCDCA SEG15	CATB SENSE29
F6	F6	PB10	42	LCDA	USART3 TXD	PEVC PAD EVT3	GLOC OUT1	TC0 B1	SCIF GCLK0	LCDCA SEG16	CATB SENSE30
H8	H8	PB11	43	LCDA	USART0 CTS	SPI NPCS2		TC0 A2	SCIF GCLK1	LCDCA SEG17	CATB SENSE31
D5	D5	PB12	44	LCDC	USART0 RTS	SPI NPCS3	PEVC PAD EVT0	TC0 B2	SCIF GCLK2	LCDCA SEG32	CATB DIS

Table 3-3. 64-pin GPIO Controller Function Multiplexing for WLCSP package (Sheet 3 of 3)

ATSAM4LC	ATSAM4LS	Pin	GPIO	Supply	GPIO Functions							
					A	B	C	D	E	F	G	
WLCSP	WLCSP											
E5	E5	PB13	45	LCDC	USART0 CLK	SPI NPCS1	PEVC PAD EVT1	TC0 CLK0	SCIF GCLK3	LCDCA SEG33	CATB SENSE0	
F4	F4	PB14	46	LCDC	USART0 RXD	SPI MISO	TWIM3 TWD	TC0 CLK1	SCIF GCLK IN0	LCDCA SEG36	CATB SENSE1	
H4	H4	PB15	47	LCDC	USART0 TXD	SPI MOSI	TWIM3 TWCK	TC0 CLK2	SCIF GCLK IN1	LCDCA SEG37	CATB SENSE2	

Table 3-4. 48-pin GPIO Controller Function Multiplexing (Sheet 1 of 2)

ATSAM4LC	ATSAM4LS	Pin	GPIO	Supply	GPIO Functions							
					A	B	C	D	E	F	G	
1	1	PA00	0	VDDIO								
2	2	PA01	1	VDDIO								
3	3	PA02	2	VDDIN	SCIF GCLK0	SPI NPCS0						CATB DIS
10	10	PA03	3	VDDIN		SPI MISO						
11	11	PA04	4	VDDANA	ADCIFE AD0	USART0 CLK	EIC EXTINT2	GLOC IN1				CATB SENSE0
12	12	PA05	5	VDDANA	ADCIFE AD1	USART0 RXD	EIC EXTINT3	GLOC IN2	ADCIFE TRIGGER			CATB SENSE1
15	15	PA06	6	VDDANA	DACC VOUT	USART0 RTS	EIC EXTINT1	GLOC IN0	ACIFC ACAN0			CATB SENSE2
16	16	PA07	7	VDDANA	ADCIFE AD2	USART0 TXD	EIC EXTINT4	GLOC IN3	ACIFC ACAP0			CATB SENSE3
20	20	PA08	8	LCDA	USART0 RTS	TC0 A0	PEVC PAD EVT0	GLOC OUT0		LCDCA SEG23		CATB SENSE4
21	21	PA09	9	LCDA	USART0 CTS	TC0 B0	PEVC PAD EVT1	PARC PCDATA0		LCDCA COM3		CATB SENSE5
22	22	PA10	10	LCDA	USART0 CLK	TC0 A1	PEVC PAD EVT2	PARC PCDATA1		LCDCA COM2		CATB SENSE6
23	23	PA11	11	LCDA	USART0 RXD	TC0 B1	PEVC PAD EVT3	PARC PCDATA2		LCDCA COM1		CATB SENSE7
24	24	PA12	12	LCDA	USART0 TXD	TC0 A2		PARC PCDATA3		LCDCA COM0		CATB DIS
32	32	PA13	13	LCDA	USART1 RTS	TC0 B2	SPI NPCS1	PARC PCDATA4		LCDCA SEG5		CATB SENSE8
33	33	PA14	14	LCDA	USART1 CLK	TC0 CLK0	SPI NPCS2	PARC PCDATA5		LCDCA SEG6		CATB SENSE9
34	34	PA15	15	LCDA	USART1 RXD	TC0 CLK1	SPI NPCS3	PARC PCDATA6		LCDCA SEG7		CATB SENSE10
35	35	PA16	16	LCDA	USART1 TXD	TC0 CLK2	EIC EXTINT1	PARC PCDATA7		LCDCA SEG8		CATB SENSE11
36	36	PA17	17	LCDA	USART2 RTS	ABDACB DAC0	EIC EXTINT2	PARC PCCK		LCDCA SEG9		CATB SENSE12
37	37	PA18	18	LCDA	USART2 CLK	ABDACB DACN0	EIC EXTINT3	PARC PCEN1		LCDCA SEG18		CATB SENSE13
38	38	PA19	19	LCDA	USART2 RXD	ABDACB DAC1	EIC EXTINT4	PARC PCEN2	SCIF GCLK0	LCDCA SEG19		CATB SENSE14
39	39	PA20	20	LCDA	USART2 TXD	ABDACB DACN1	EIC EXTINT5	GLOC IN0	SCIF GCLK1	LCDCA SEG20		CATB SENSE15
41	41	PA21	21	LCDC	SPI MISO	USART1 CTS	EIC EXTINT6	GLOC IN1	TWIM2 TWD	LCDCA SEG34		CATB SENSE16
42	42	PA22	22	LCDC	SPI MOSI	USART2 CTS	EIC EXTINT7	GLOC IN2	TWIM2 TWCK	LCDCA SEG35		CATB SENSE17
43	43	PA23	23	LCDC	SPI SCK	TWIMS0 TWD	EIC EXTINT8	GLOC IN3	SCIF GCLK IN0	LCDCA SEG38		CATB DIS

Table 3-4. 48-pin GPIO Controller Function Multiplexing (Sheet 2 of 2)

ATSAM4LC	ATSAM4LS	Pin	GPIO	Supply	GPIO Functions						
					A	B	C	D	E	F	G
44	44	PA24	24	LCDC	SPI NPCS0	TWIMS0 TWCK		GLOC OUT0	SCIF GCLK IN1	LCDC SEG39	CATB SENSE18
46	46	PA25	25	VDDIO	USBC DM	USART2 RXD					CATB SENSE19
47	47	PA26	26	VDDIO	USBC DP	USART2 TXD					CATB SENSE20
	25	PA27	27	LCDA	SPI MISO	IISC ISCK	ABDACB DAC0	GLOC IN4	USART3 RTS		CATB SENSE0
	26	PA28	28	LCDA	SPI MOSI	IISC ISDI	ABDACB DACN0	GLOC IN5	USART3 CTS		CATB SENSE1
	27	PA29	29	LCDA	SPI SCK	IISC IWS	ABDACB DAC1	GLOC IN6	USART3 CLK		CATB SENSE2
	30	PA30	30	LCDA	SPI NPCS0	IISC ISDO	ABDACB DACN1	GLOC IN7	USART3 RXD		CATB SENSE3
	31	PA31	31	LCDA	SPI NPCS1	IISC IMCK	ABDACB CLK	GLOC OUT1	USART3 TXD		CATB DIS

3.2.2 Peripheral Functions

Each GPIO line can be assigned to one of several peripheral functions. The following table describes how the various peripheral functions are selected. The last listed function has priority in case multiple functions are enabled on the same pin.

Table 3-5. Peripheral Functions

Function	Description
GPIO Controller Function multiplexing	GPIO and GPIO peripheral selection A to H
JTAG port connections	JTAG debug port
Oscillators	OSC0

3.2.3 JTAG Port Connections

If the JTAG is enabled, the JTAG will take control over a number of pins, irrespectively of the I/O Controller configuration.

Table 3-6. JTAG Pinout

48-pin Packages	64-pin QFP/QFN	64-pin WLSCP	100-pin QFN	100-ball VFBGA	Pin Name	JTAG Pin
10	10	E2	19	B3	PA03	TMS
43	59	H3	95	D6	PA23	TDO
44	60	H2	96	D10	PA24	TDI
9	9	F2	18	B4	TCK	TCK

3.2.4 ITM Trace Connections

If the ITM trace is enabled, the ITM will take control over the pin PA23, irrespectively of the I/O Controller configuration. The Serial Wire Trace signal is available on pin PA23

3.2.5 Oscillator Pinout

The oscillators are not mapped to the normal GPIO functions and their muxings are controlled by registers in the System Control Interface (SCIF) or Backup System Control Interface (BSCIF). Refer to the [Section 15. "System Control Interface \(SCIF\)" on page 308](#) and [Section 15. "Backup System Control Interface \(BSCIF\)" on page 308](#) for more information about this.

Table 3-7. Oscillator Pinout

48-pin Packages	64-pin QFN/QFP	64-pin WLCSP	100-pin Packages	100-ball VFBGA	Pin Name	Oscillator Pin
1	1	G4	5	B9	PA00	XIN0
13	17	B2	26	B2	XIN32	XIN32
2	2	G5	6	B8	PA01	XOUT0
14	18	B3	27	C2	XOUT32	XOUT32

3.3 Signals Description

The following table gives details on signal names classified by peripheral.

Table 3-8. Signal Descriptions List (Sheet 1 of 4)

Signal Name	Function	Type	Active Level	Comments
Audio Bitstream DAC - ABDACB				
CLK	D/A clock output	Output		
DAC1 - DAC0	D/A bitstream outputs	Output		
DACN1 - DACN0	D/A inverted bitstream outputs	Output		
Analog Comparator Interface - ACIFC				
ACAN1 - ACAN0	Analog Comparator A negative references	Analog		
ACAP1 - ACAP0	Analog Comparator A positive references	Analog		
ACBN1 - ACBN0	Analog Comparator B negative references	Analog		
ACBP1 - ACBP0	Analog Comparator B positive references	Analog		
ADC controller interface - ADCIFE				
AD14 - AD0	Analog inputs	Analog		
ADVREFP	Positive voltage reference	Analog		
TRIGGER	External trigger	Input		
Backup System Control Interface - BSCIF				
XIN32	32 kHz Crystal Oscillator Input	Analog/ Digital		
XOUT32	32 kHz Crystal Oscillator Output	Analog		
Capacitive Touch Module B - CATB				
DIS	Capacitive discharge line	Output		
SENSE31 - SENSE0	Capacitive sense lines	I/O		
DAC Controller - DACC				
DAC external trigger	DAC external trigger	Input		
DAC voltage output	DAC voltage output	Analog		
Enhanced Debug Port For ARM Products - EDP				
TCK/SWCLK	JTAG / SW Debug Clock	Input		
TDI	JTAG Debug Data In	Input		
TDO/TRACESWO	JTAG Debug Data Out / SW Trace Out	Output		
TMS/SWDIO	JTAG Debug Mode Select / SW Data	I/O		
External Interrupt Controller - EIC				
EXTINT8 - EXTINT0	External interrupts	Input		
Glue Logic Controller - GLOC				
IN7 - IN0	Lookup Tables Inputs	Input		
OUT1 - OUT0	Lookup Tables Outputs	Output		

Table 3-8. Signal Descriptions List (Sheet 2 of 4)

Signal Name	Function	Type	Active Level	Comments
Inter-IC Sound (I2S) Controller - IISC				
IMCK	I2S Master Clock	Output		
ISCK	I2S Serial Clock	I/O		
ISDI	I2S Serial Data In	Input		
ISDO	I2S Serial Data Out	Output		
IWS	I2S Word Select	I/O		
LCD Controller - LCDCA				
BIASL	Bias voltage (1/3 VLCD)	Analog		
BIASH	Bias voltage (2/3 VLCD)	Analog		
CAPH	High voltage end of flying capacitor	Analog		
CAPL	Low voltage end of flying capacitor	Analog		
COM3 - COM0	Common terminals	Analog		
SEG39 - SEG0	Segment terminals	Analog		
VLCD	Bias voltage	Analog		
Parallel Capture - PARC				
PCCK	Clock	Input		
PCDATA7 - PCDATA0	Data lines	Input		
PCEN1	Data enable 1	Input		
PCEN2	Data enable 2	Input		
Peripheral Event Controller - PEVC				
PAD_EVT3 - PAD_EVT0	Event Inputs	Input		
Power Manager - PM				
RESET_N	Reset	Input	Low	
System Control Interface - SCIF				
GCLK3 - GCLK0	Generic Clock Outputs	Output		
GCLK_IN1 - GCLK_IN0	Generic Clock Inputs	Input		
XIN0	Crystal 0 Input	Analog/ Digital		
XOUT0	Crystal 0 Output	Analog		
Serial Peripheral Interface - SPI				
MISO	Master In Slave Out	I/O		
MOSI	Master Out Slave In	I/O		
NPCS3 - NPCS0	SPI Peripheral Chip Selects	I/O	Low	
SCK	Clock	I/O		
Timer/Counter - TC0, TC1				

Table 3-8. Signal Descriptions List (Sheet 3 of 4)

Signal Name	Function	Type	Active Level	Comments
A0	Channel 0 Line A	I/O		
A1	Channel 1 Line A	I/O		
A2	Channel 2 Line A	I/O		
B0	Channel 0 Line B	I/O		
B1	Channel 1 Line B	I/O		
B2	Channel 2 Line B	I/O		
CLK0	Channel 0 External Clock Input	Input		
CLK1	Channel 1 External Clock Input	Input		
CLK2	Channel 2 External Clock Input	Input		
Two-wire Interface - TWIMS0, TWIMS1, TWIM2, TWIM3				
TWCK	Two-wire Serial Clock	I/O		
TWD	Two-wire Serial Data	I/O		
Universal Synchronous Asynchronous Receiver Transmitter - USART0, USART1, USART2, USART3				
CLK	Clock	I/O		
CTS	Clear To Send	Input	Low	
RTS	Request To Send	Output	Low	
RXD	Receive Data	Input		
TXD	Transmit Data	Output		
USB 2.0 Interface - USBC				
DM	USB Full Speed Interface Data -	I/O		
DP	USB Full Speed Interface Data +	I/O		
Power				
GND	Ground	Ground		
GNDANA	Analog Ground	Ground		
VDDANA	Analog Power Supply	Power Input		1.68V to 3.6V
VDDCORE	Core Power Supply	Power Input		1.68V to 1.98V
VDDIN	Voltage Regulator Input	Power Input		1.68V to 3.6V
VDDIO	I/O Pads Power Supply	Power Input		1.68V to 3.6V. VDDIO must always be equal to or lower than VDDIN.
VDDOUT	Voltage Regulator Output	Power Output		1.08V to 1.98V
General Purpose I/O				

Table 3-8. Signal Descriptions List (Sheet 4 of 4)

Signal Name	Function	Type	Active Level	Comments
PA31 - PA00	Parallel I/O Controller I/O Port A	I/O		
PB15 - PB00	Parallel I/O Controller I/O Port B	I/O		
PC31 - PC00	Parallel I/O Controller I/O Port C	I/O		

Note: 1. See [“Power and Startup Considerations”](#) section.

3.4 I/O Line Considerations

3.4.1 SW/JTAG Pins

The JTAG pins switch to the JTAG functions if a rising edge is detected on TCK low after the RESET_N pin has been released. The TMS, and TDI pins have pull-up resistors when used as JTAG pins. The TCK pin always has pull-up enabled during reset. The JTAG pins can be used as GPIO pins and multiplexed with peripherals when the JTAG is disabled. Refer to [Section 3.2.3 “JTAG Port Connections” on page 28](#) for the JTAG port connections.

For more details, refer to [Section 1.1 “Enhanced Debug Port \(EDP\)” on page 3](#).

3.4.2 RESET_N Pin

The RESET_N pin is a schmitt input and integrates a permanent pull-up resistor to VDDIN. As the product integrates a power-on reset detector, the RESET_N pin can be left unconnected in case no reset from the system needs to be applied to the product.

3.4.3 TWI Pins

When these pins are used for TWI, the pins are open-drain outputs with slew-rate limitation and inputs with inputs with spike-filtering. When used as GPIO-pins or used for other peripherals, the pins have the same characteristics as GPIO pins.

3.4.4 GPIO Pins

All the I/O lines integrate a pull-up/pull-down resistor and slew rate controller. Programming these features is performed independently for each I/O line through the GPIO Controllers. After reset, I/O lines default as inputs with pull-up and pull-down resistors disabled and slew rate enabled.

3.4.5 High-drive Pins

The six pins PA02, PB00, PB01, PC04, PC05 and PC06 have high-drive output capabilities. Refer to [Section 9.6.2 “High-drive I/O Pin : PA02, PC04, PC05, PC06” on page 114](#) for electrical characteristics.

3.4.6 USB Pins

When these pins are used for USB, the pins are behaving according to the USB specification. When used as GPIO pins or used for other peripherals, the pins have the same behavior as other normal I/O pins, but the characteristics are different. Refer to [Section 9.6.3 “USB I/O Pin : PA25, PA26” on page 115](#) for electrical characteristics.

These pins are compliant to USB standard only when VDDIO power supply is 3.3V nominal.

3.4.7 ADC Input Pins

These pins are regular I/O pins powered from the VDDANA.

4. Cortex-M4 processor and core peripherals

4.1 Cortex-M4

The Cortex-M4 processor is a high performance 32-bit processor designed for the microcontroller market. It offers significant benefits to developers, including:

- outstanding processing performance combined with fast interrupt handling
- enhanced system debug with extensive breakpoint and trace capabilities
- efficient processor core, system and memories
- ultra-low power consumption with integrated sleep modes
- platform security robustness, with integrated memory protection unit (MPU).

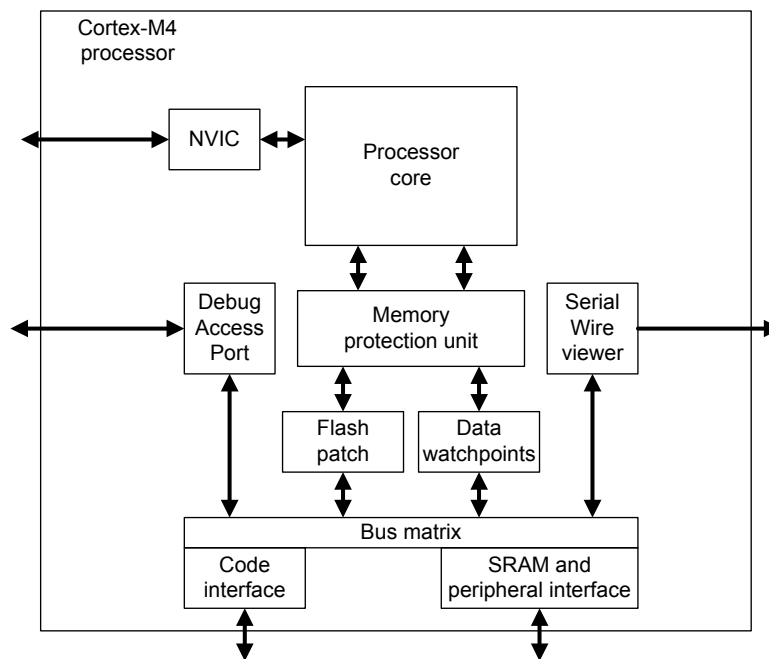

The Cortex-M4 processor is built on a high-performance processor core, with a 3-stage pipeline Harvard architecture, making it ideal for demanding embedded applications. The processor delivers exceptional power efficiency through an efficient instruction set and extensively optimized design, providing high-end processing hardware including a range of single-cycle and SIMD multiplication and multiply-with-accumulate capabilities, saturating arithmetic and dedicated hardware division.

To facilitate the design of cost-sensitive devices, the Cortex-M4 processor implements tightly-coupled system components that reduce processor area while significantly improving interrupt handling and system debug capabilities. The Cortex-M4 processor implements a version of the Thumb® instruction set based on Thumb-2 technology, ensuring high code density and reduced program memory requirements. The Cortex-M4 instruction set provides the exceptional performance expected of a modern 32-bit architecture, with the high code density of 8-bit and 16-bit microcontrollers.

The Cortex-M4 processor closely integrates a configurable Nested Vectored Interrupt Controller (NVIC), to deliver industry-leading interrupt performance. The NVIC includes a *non-maskable interrupt* (NMI), and provides up to 80 interrupt priority levels. The tight integration of the proces-

processor core and NVIC provides fast execution of interrupt service routines (ISRs), dramatically reducing the interrupt latency. This is achieved through the hardware stacking of registers, and the ability to suspend load-multiple and store-multiple operations. Interrupt handlers do not require wrapping in assembler code, removing any code overhead from the ISRs. A tail-chain optimization also significantly reduces the overhead when switching from one ISR to another.

To optimize low-power designs, the NVIC integrates with the sleep modes, that include a deep sleep function enabling the entire device to be rapidly powered down while still retaining program state.

4.2 System level interface

The Cortex-M4 processor provides multiple interfaces using AMBA® technology to provide high speed, low latency memory accesses. It supports unaligned data accesses and implements atomic bit manipulation that enables faster peripheral controls, system spinlocks and thread-safe Boolean data handling.

The Cortex-M4 processor has an *memory protection unit* (MPU) that provides fine grain memory control, enabling applications to utilize multiple privilege levels, separating and protecting code, data and stack on a task-by-task basis. Such requirements are becoming critical in many embedded applications such as automotive.

4.3 Integrated configurable debug

The Cortex-M4 processor implements a complete hardware debug solution. This provides high system visibility of the processor and memory through either a traditional JTAG port or a 2-pin *Serial Wire Debug* (SWD) port that is ideal for microcontrollers and other small package devices.

For system trace the processor integrates an *Instrumentation Trace Macrocell* (ITM) alongside data watchpoints and a profiling unit. To enable simple and cost-effective profiling of the system events these generate, a *Serial Wire Viewer* (SWV) can export a stream of software-generated messages, data trace, and profiling information through a single pin.

The *Flash Patch and Breakpoint Unit* (FPB) provides 8 hardware breakpoint comparators that debuggers can use. The comparators in the FPB also provide remap functions of up to 8 words in the program code in the CODE memory region. This enables applications stored on a non-erasable, ROM-based microcontroller to be patched if a small programmable memory, for example flash, is available in the device. During initialization, the application in ROM detects, from the programmable memory, whether a patch is required. If a patch is required, the application programs the FPB to remap a number of addresses. When those addresses are accessed, the accesses are redirected to a remap table specified in the FPB configuration, which means the program in the non-modifiable ROM can be patched.

A specific Peripheral Debug (PDBG) register is implemented in the Private Peripheral Bus address map. This register allows the user to configure the behavior of some modules in debug mode.

4.4 Cortex-M4 processor features and benefits summary

- tight integration of system peripherals reduces area and development costs
- Thumb instruction set combines high code density with 32-bit performance
- code-patch ability for ROM system updates
- power control optimization of system components
- integrated sleep modes for low power consumption
- fast code execution permits slower processor clock or increases sleep mode time
- hardware division and fast digital-signal-processing orientated multiply accumulate
- saturating arithmetic for signal processing
- deterministic, high-performance interrupt handling for time-critical applications
- *memory protection unit* (MPU) for safety-critical applications
- extensive debug and trace capabilities:
 - Serial Wire Debug and Serial Wire Trace reduce the number of pins required for debugging, tracing, and code profiling.

4.5 Cortex-M4 core peripherals

These are:

Nested Vectored Interrupt Controller

The NVIC is an embedded interrupt controller that supports low latency interrupt processing.

System control block

The *System control block* (SCB) is the programmers model interface to the processor. It provides system implementation information and system control, including configuration, control, and reporting of system exceptions.

System timer

The system timer, SysTick, is a 24-bit count-down timer. Use this as a Real Time Operating System (RTOS) tick timer or as a simple counter.

Memory protection unit

The *Memory protection unit* (MPU) improves system reliability by defining the memory attributes for different memory regions. It provides up to eight different regions, and an optional predefined background region.

The complete Cortex-M4 User Guide can be found on the ARM web site:

http://infocenter.arm.com/help/topic/com.arm.doc.dui0553a/DUI0553A_cortex_m4_dgug.pdf

4.6 Cortex-M4 implementations options

This table provides the specific configuration options implemented in the SAM4L series

Option	Implementation
Inclusion of MPU	yes
Inclusion of FPU	No
Number of interrupts	80
Number of priority bits	4
Inclusion of the WIC	No
Embedded Trace Macrocell	No
Sleep mode instruction	Only WFI supported
Endianness	Little Endian
Bit-banding	No
SysTick timer	Yes
Register reset values	No

Table 4-1. Cortex-M4 implementation options

4.7 Cortex-M4 Interrupts map

The table below shows how the interrupt request signals are connected to the NVIC.

Table 4-2. Interrupt Request Signal Map (Sheet 1 of 3)

Line	Module	Signal
0	Flash Controller	HFLASHC
1	Peripheral DMA Controller	PDCA 0
2	Peripheral DMA Controller	PDCA 1
3	Peripheral DMA Controller	PDCA 2
4	Peripheral DMA Controller	PDCA 3
5	Peripheral DMA Controller	PDCA 4
6	Peripheral DMA Controller	PDCA 5
7	Peripheral DMA Controller	PDCA 6
8	Peripheral DMA Controller	PDCA 7
9	Peripheral DMA Controller	PDCA 8
10	Peripheral DMA Controller	PDCA 9
11	Peripheral DMA Controller	PDCA 10

Table 4-2. Interrupt Request Signal Map (Sheet 2 of 3)

Line	Module	Signal
12	Peripheral DMA Controller	PDCA 11
13	Peripheral DMA Controller	PDCA 12
14	Peripheral DMA Controller	PDCA 13
15	Peripheral DMA Controller	PDCA 14
16	Peripheral DMA Controller	PDCA 15
17	CRC Calculation Unit	CRCCU
18	USB 2.0 Interface	USBC
19	Peripheral Event Controller	PEVC TR
20	Peripheral Event Controller	PEVC OV
21	Advanced Encryption Standard	AESA
22	Power Manager	PM
23	System Control Interface	SCIF
24	Frequency Meter	FREQM
25	General-Purpose Input/Output Controller	GPIO 0
26	General-Purpose Input/Output Controller	GPIO 1
27	General-Purpose Input/Output Controller	GPIO 2
28	General-Purpose Input/Output Controller	GPIO 3
29	General-Purpose Input/Output Controller	GPIO 4
30	General-Purpose Input/Output Controller	GPIO 5
31	General-Purpose Input/Output Controller	GPIO 6
32	General-Purpose Input/Output Controller	GPIO 7
33	General-Purpose Input/Output Controller	GPIO 8
34	General-Purpose Input/Output Controller	GPIO 9
35	General-Purpose Input/Output Controller	GPIO 10
36	General-Purpose Input/Output Controller	GPIO 11
37	Backup Power Manager	BPM
38	Backup System Control Interface	BSCIF
39	Asynchronous Timer	AST ALARM
40	Asynchronous Timer	AST PER
41	Asynchronous Timer	AST OVF
42	Asynchronous Timer	AST READY
43	Asynchronous Timer	AST CLKREADY
44	Watchdog Timer	WDT
45	External Interrupt Controller	EIC 1
46	External Interrupt Controller	EIC 2
47	External Interrupt Controller	EIC 3

Table 4-2. Interrupt Request Signal Map (Sheet 3 of 3)

Line	Module	Signal
48	External Interrupt Controller	EIC 4
49	External Interrupt Controller	EIC 5
50	External Interrupt Controller	EIC 6
51	External Interrupt Controller	EIC 7
52	External Interrupt Controller	EIC 8
53	Inter-IC Sound (I2S) Controller	IISC
54	Serial Peripheral Interface	SPI
55	Timer/Counter	TC00
56	Timer/Counter	TC01
57	Timer/Counter	TC02
58	Timer/Counter	TC10
59	Timer/Counter	TC11
60	Timer/Counter	TC12
61	Two-wire Master Interface	TWIM0
62	Two-wire Slave Interface	TWIS0
63	Two-wire Master Interface	TWIM1
64	Two-wire Slave Interface	TWIS1
65	Universal Synchronous Asynchronous Receiver Transmitter	USART0
66	Universal Synchronous Asynchronous Receiver Transmitter	USART1
67	Universal Synchronous Asynchronous Receiver Transmitter	USART2
68	Universal Synchronous Asynchronous Receiver Transmitter	USART3
69	ADC controller interface	ADCIFE
70	DAC Controller	DACC
71	Analog Comparator Interface	ACIFC
72	Audio Bitstream DAC	ABDACB
73	True Random Number Generator	TRNG
74	Parallel Capture	PARC
75	Capacitive Touch Module B	CATB
77	Two-wire Master Interface	TWIM2
78	Two-wire Master Interface	TWIM3
79	LCD Controller A	LCDCA

4.8 Peripheral Debug

The PDBG register controls the behavior of asynchronous peripherals when the device is in debug mode. When the corresponding bit is set, that peripheral will be in a frozen state in debug mode.

4.8.1 Peripheral Debug

Name: PDBG
Access Type: Read/Write
Address: 0xE0042000
Reset Value: 0x00000000

31	30	29	28	27	26	25	24
-	-	-	-	-	-	-	-
23	22	21	20	19	18	17	16
-	-	-	-	-	-	-	-
15	14	13	12	11	10	9	8
-	-	-	-	-	-	-	-
7	6	5	4	3	2	1	0
-	-	-	-	-	PEVC	AST	WDT

- WDT: Watchdog PDBG bit**
 WDT = 0: The WDT counter is not frozen during debug operation.
 WDT = 1: The WDT counter is frozen during debug operation when Core is halted
- AST: Asynchronous Timer PDBG bit**
 AST = 0: The AST prescaler and counter is not frozen during debug operation.
 AST = 1: The AST prescaler and counter is frozen during debug operation when Core is halted.
- PEVC: PEVC PDBG bit**
 PEVC = 0: PEVC is not frozen during debug operation.
 PEVC = 1: PEVC is frozen during debug operation when Core is halted.

5. Memories

5.1 Product Mapping

Figure 5-1. ATSAM4L8/L4/L2 Product Mapping

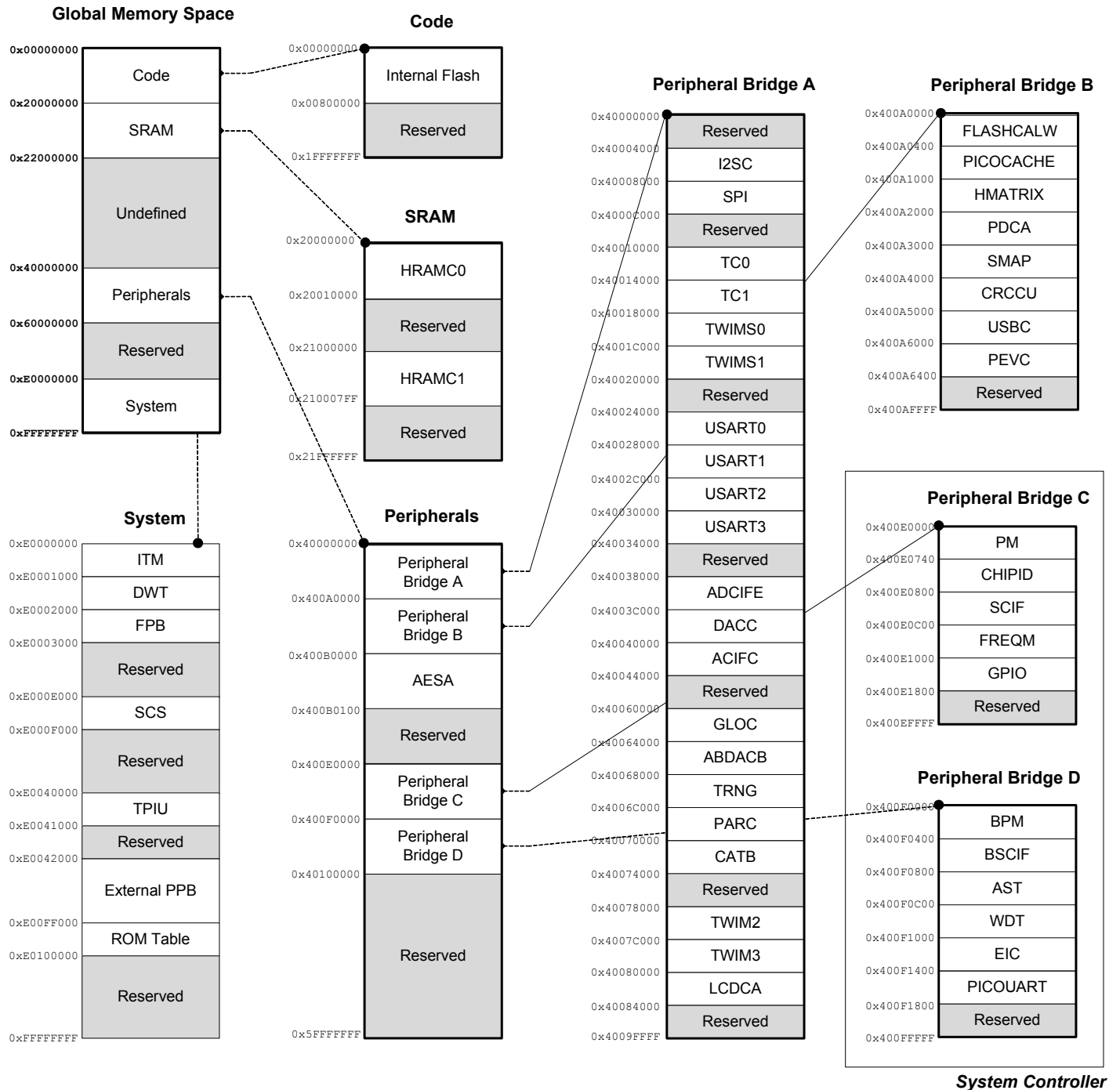

5.2 Embedded Memories

- Internal high-speed flash
 - 512Kbytes (ATSAM4Lx8)
 - 256Kbytes (ATSAM4Lx4)
 - 128Kbytes (ATSAM4Lx2)
 - Pipelined flash architecture, allowing burst reads from sequential flash locations, hiding penalty of 1 wait state access
 - Pipelined flash architecture typically reduces the cycle penalty of 1 wait state operation compared to 0 wait state operation
 - 100 000 write cycles, 15-year data retention capability
 - Sector lock capabilities, bootloader protection, security bit
 - 32 fuses, erased during chip erase
 - User page for data to be preserved during chip erase
- Internal high-speed SRAM, single-cycle access at full speed
 - 64Kbytes (ATSAM4Lx8)
 - 32Kbytes (ATSAM4Lx4, ATSAM4Lx2)

5.3 Physical Memory Map

The system bus is implemented as a bus matrix. All system bus addresses are fixed, and they are never remapped in any way, not even during boot. The 32-bit physical address space is mapped as follows:

Table 5-1. ATSAM4L8/L4/L2 Physical Memory Map

Memory	Start Address	Size	
		ATSAM4Lx4	ATSAM4Lx2
Embedded Flash	0x00000000	256Kbytes	128Kbytes
Embedded SRAM	0x20000000	32Kbytes	32Kbytes
Cache SRAM	0x21000000	4Kbytes	4Kbytes
Peripheral Bridge A	0x40000000	64Kbytes	64Kbytes
Peripheral Bridge B	0x400A0000	64Kbytes	64Kbytes
AESA	0x400B0000	256 bytes	256 bytes
Peripheral Bridge C	0x400E0000	64Kbytes	64Kbytes
Peripheral Bridge D	0x400F0000	64Kbytes	64Kbytes

Memory	Start Address	Size
		ATSAM4Lx8
Embedded Flash	0x00000000	512Kbytes
Embedded SRAM	0x20000000	64Kbytes
Cache SRAM	0x21000000	4Kbytes
Peripheral Bridge A	0x40000000	64Kbytes
Peripheral Bridge B	0x400A0000	64Kbytes

Memory	Start Address	Size
AESA	0x400B0000	256 bytes
Peripheral Bridge C	0x400E0000	64Kbytes
Peripheral Bridge D	0x400F0000	64Kbytes

Table 5-2. Flash Memory Parameters

Device	Flash Size (<i>FLASH_PW</i>)	Number of Pages (<i>FLASH_P</i>)	Page Size (<i>FLASH_W</i>)
ATSAM4Lx8	512Kbytes	1024	512 bytes
ATSAM4Lx4	256Kbytes	512	512 bytes
ATSAM4Lx2	128Kbytes	256	512 bytes

6. Power and Startup Considerations

6.1 Power Domain Overview

Figure 6-1. ATSAM4LS Power Domain Diagram

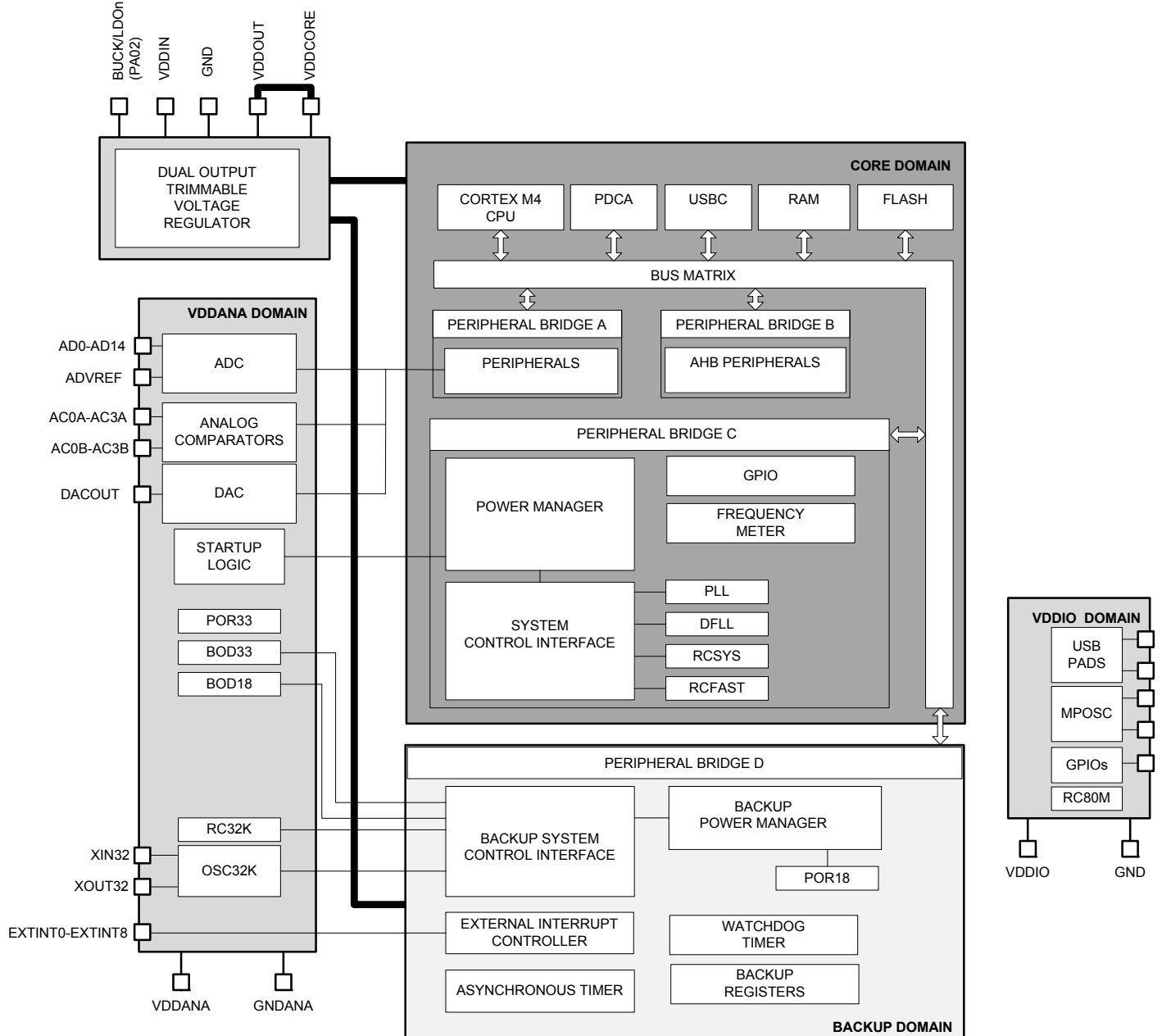
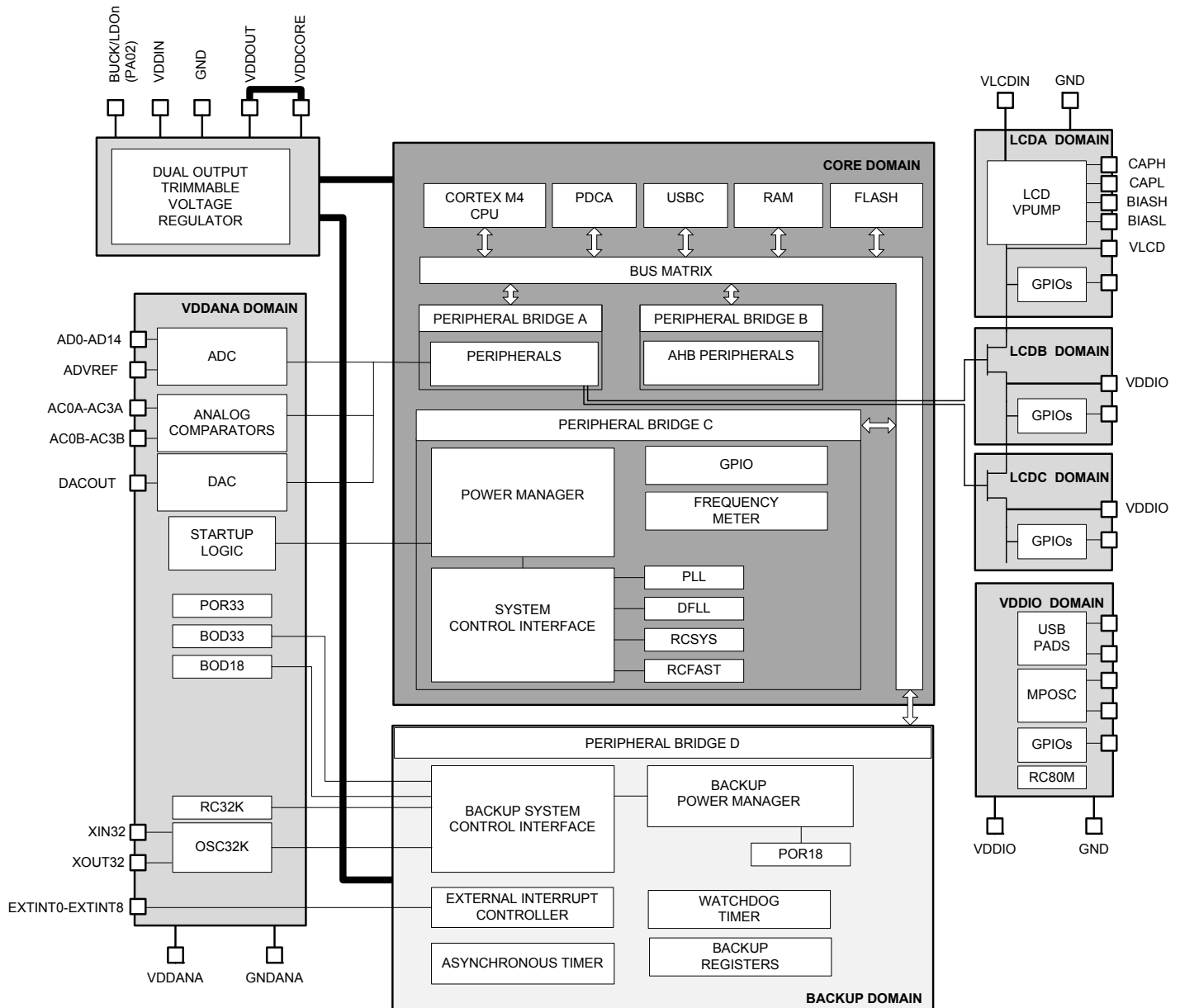

Figure 6-2. ATSAM4LC Power Domain Diagram



6.2 Power Supplies

The ATSAM4L8/L4/L2 has several types of power supply pins:

- VDDIO: Powers I/O lines, the general purpose oscillator (OSC), the 80MHz integrated RC oscillator (RC80M) . Voltage is 1.68V to 3.6V.
- VLCDIN: (ATSAM4LC only) Powers the LCD voltage pump. Voltage is 1.68V to 3.6V.
- VDDIN: Powers the internal voltage regulator. Voltage is 1.68V to 3.6V.
- VDDANA: Powers the ADC, the DAC, the Analog Comparators, the 32kHz oscillator (OSC32K), the 32kHz integrated RC oscillator (RC32K) and the Brown-out detectors (BOD18 and BOD33). Voltage is 1.68V to 3.6V nominal.
- VDDCORE: Powers the core, memories, peripherals, the PLL, the DFLL, the 4MHz integrated RC oscillator (RCFAST) and the 115kHz integrated RC oscillator (RCSYS).
 - VDDOUT is the output voltage of the regulator and must be connected with or without an inductor to VDDCORE.

The ground pins GND are common to VDDCORE, VDDIO, and VDDIN. The ground pin for VDDANA is GNDANA.

For decoupling recommendations for the different power supplies, refer to the schematic document.

6.2.1 Voltage Regulator

An embedded voltage regulator supplies all the digital logic in the Core and the Backup power domains.

The regulator has two functional mode depending of BUCK/LDOn (PA02) pin value. When this pin is low, the regulator is in linear mode and VDDOUT must be connected to VDDCORE externally. When this pin is high, it behaves as a switching regulator and an inductor must be placed between VDDOUT and VDDCORE. The value of this pin is sampled during the power-up phase when the Power On Reset 33 reaches V_{POT+} ([Section 9.9 "Analog Characteristics" on page 128](#))

Its output voltages in the Core domain (V_{CORE}) and in the Backup domain (V_{BKUP}) are always equal except in Backup mode where the Core domain is not powered ($V_{CORE}=0$). The Backup domain is always powered. The voltage regulator features three different modes:

- Normal mode: the regulator is configured as linear or switching regulator. It can support all different Run and Sleep modes.
- Low Power (LP) mode: the regulator consumes little static current. It can be used in Wait modes.
- Ultra Low Power (ULP) mode: the regulator consumes very little static current . It is dedicated to Retention and Backup modes. In Backup mode, the regulator only supplies the backup domain.

6.2.2 Typical Powering Schematics

The ATSAM4L8/L4/L2 supports the Single supply mode from 1.68V to 3.6V. Depending on the input voltage range and on the final application frequency, it is recommended to use the following table in order to choose the most efficient power strategy

Figure 6-3. Efficient power strategy:

	VDDIN Voltage				
	1.68V	1.80V	2.00V	2.30V	3.60V
Switching Mode (BUCK/LDO _n (PA02) =1)	N/A		Possible but not efficient	Optimal power efficiency	
Linear Mode (BUCK/LDO _n (PA02) =0)	Optimal power efficiency			Possible but not efficient	
F _{CPUMAX}	12MHz	Up to 36MHz In PS0 Up to 12MHz in PS1 Up to 48MHz in PS2			
PowerScaling	PS1 ⁽¹⁾	ALL			
Typical power consumption in RUN mode	<ul style="list-style-type: none"> □ 212µA/MHz @ F_{CPU}=12MHz(PS1) □ 306µA/MHz @ F_{CPU}= 48MHz(PS2) 			<ul style="list-style-type: none"> □ 100µA/MHz @ F_{CPU}=12MHz(PS1) @ V_{VDDIN}=3.3V □ 180µA/MHz @ F_{CPU}=48MHz(PS2) @ V_{VDDIN}=3.3V 	
Typical power consumption in RET mode	1.5µA				

Note 1. The SAM4L boots in PS0 on RCSYS(115kHz), then the application must switch to PS1 before running on higher frequency (<12MHz)

The internal regulator is connected to the VDDIN pin and its output VDDOUT feeds VDDCORE in linear mode or through an inductor in switching mode. Figure 6-4 shows the power schematics to be used. All I/O lines will be powered by the same power ($V_{VDDIN}=V_{VDDIO}=V_{VDDANA}$).

Figure 6-4. Single Supply Mode

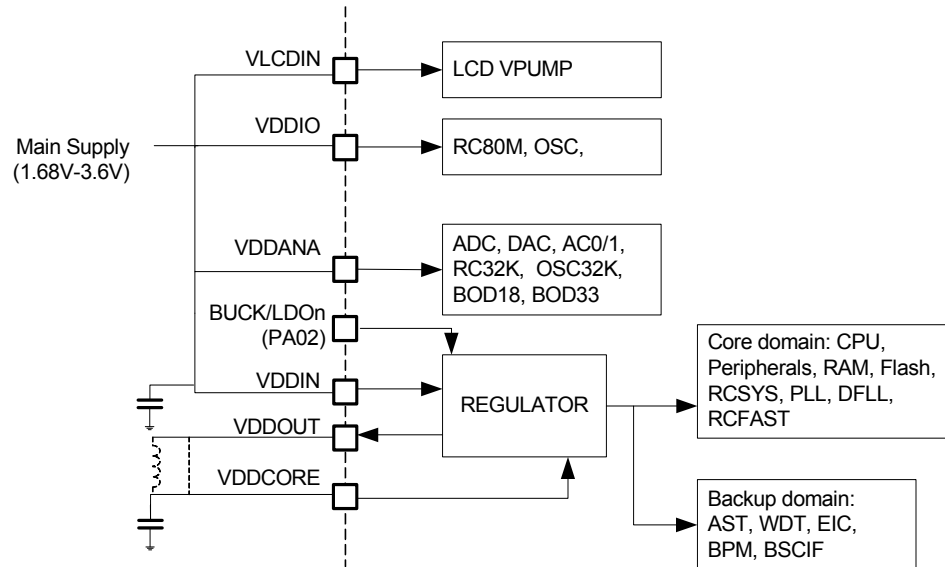

6.2.3 LCD Power Modes

6.2.3.1 Principle

LCD lines is powered using the device internal voltage sources provided by the LCDPWR block. When enabled, the LCDPWR blocks will generate the VLCD, BIASL, BIASH voltages.

LCD pads are splitted into three clusters that can be powered independently namely clusters A, B and C. A cluster can either be in GPIO mode or in LCD mode.

When a cluster is in GPIO mode, its VDDIO pin must be powered externally. None of its GPIO pin can be used as a LCD line

When a cluster is in LCD mode, each clusters VDDIO pin can be either forced externally (1.8-3.6V) or unconnected (nc). GPIOs in a cluster are not available when it is in LCD mode. A cluster is set in LCD mode by the LCDCA controller when it is enabled depending on the number of segments configured. The LCDPWR block is powered by the VLCDIN pin inside cluster A

When LCD feature is not used, VLCDIN must be always powered (1.8-3.6V). VLCD, CAPH, CAPL, BIASH, BIASL can be left unconnected in this case

Figure 6-5. LCD clusters in the device

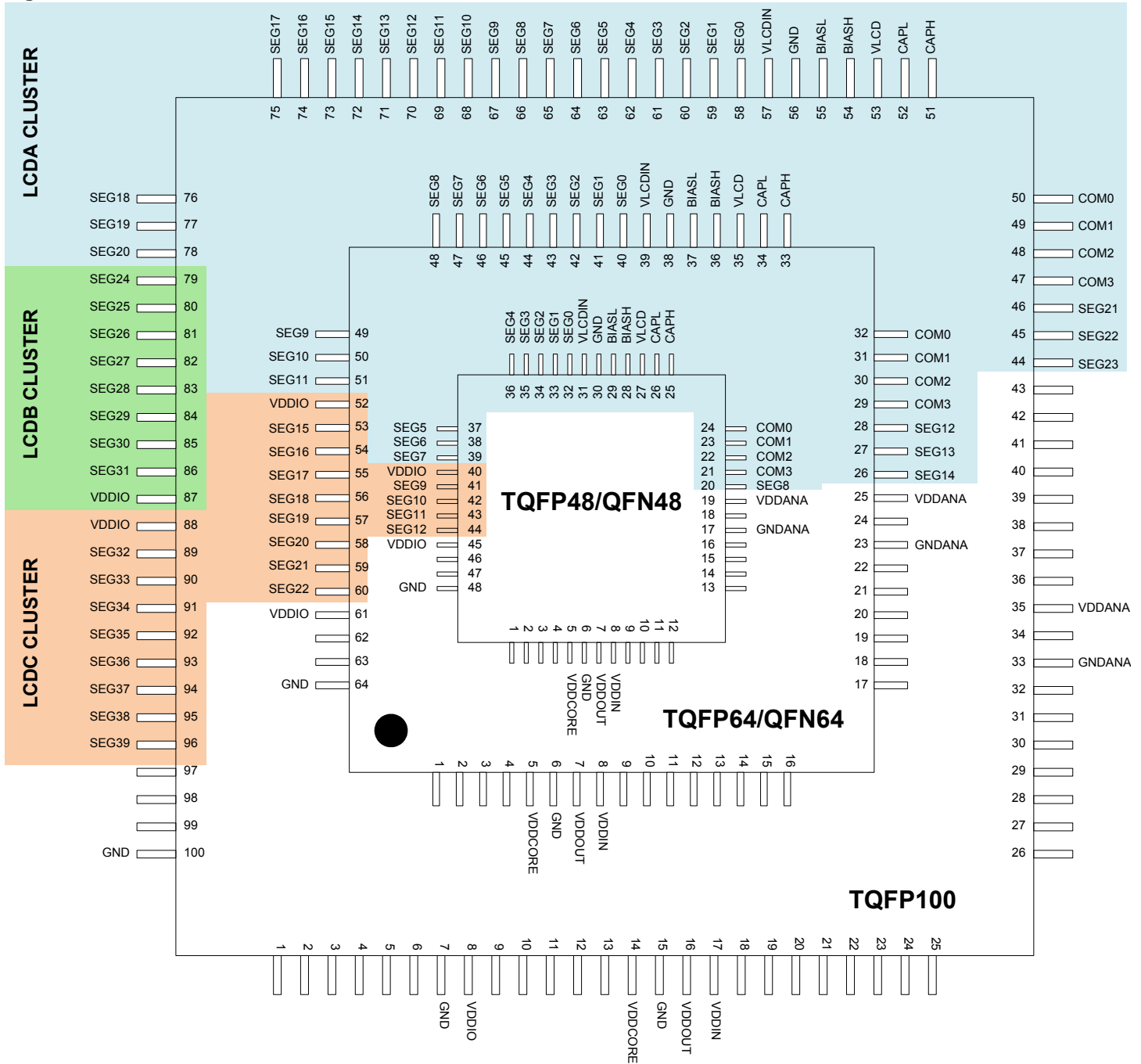

6.2.3.2 Internal LCD Voltage

In this mode the LCD voltages are internally generated. Depending of the number of segments required by the application, LCDB and LDCC clusters VDDIO pin must be unconnected (nc) or

connected to an external voltage source (1.8-3.6V). LCDB cluster is not available in 64 and 48 pin packages

Table 6-1. LCD powering when using the internal voltage pump

Package	Segments in use	VDDIO LCDB	VDDIO LCDC
100-pin packages	[1,24]	1.8-3.6V	1.8-3.6V
	[1, 32]	nc	1.8-3.6V
	[1, 40]	nc	nc
64-pin packages	[1,15]	-	1.8-3.6V
	[1, 23]	-	nc
48-pin packages	[1,9]	-	1.8-3.6V
	[1,13]	-	nc

Up to 4x40 segments
No GPIO in LCD clusters

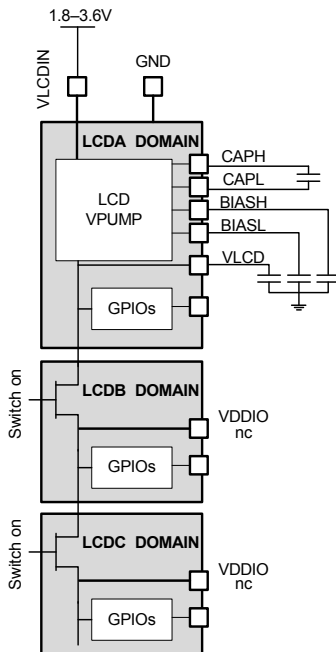

Up to 4x32 segments
Up to 8 GPIOs in LCDC clusters

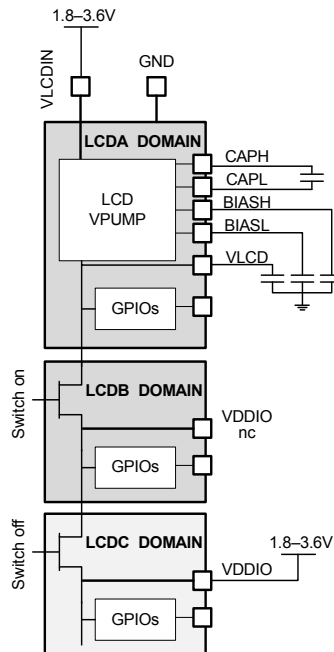

Up to 4x24 segments
Up to 16 GPIOs in LCDB & LCDC clusters

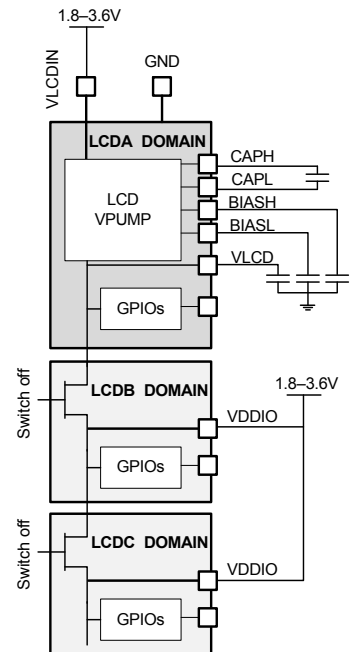

6.2.4 Power-up Sequence

6.2.4.1 Maximum Rise Rate

To avoid risk of latch-up, the rise rate of the power supplies must not exceed the values described in [Table 9-3 on page 99](#).

6.2.4.2 Minimum Rise Rate

The integrated Power-on Reset (POR33) circuitry monitoring the VDDIN powering supply requires a minimum rise rate for the VDDIN power supply.

See [Table 9-3 on page 99](#) for the minimum rise rate value.

If the application can not ensure that the minimum rise rate condition for the VDDIN power supply is met, the following configuration can be used:

- A logic “0” value is applied during power-up on pin RESET_N until VDDIN rises above 1.6 V.

6.3 Startup Considerations

This section summarizes the boot sequence of the ATSAM4L8/L4/L2. The behavior after power-up is controlled by the Power Manager. For specific details, refer to [Section 9. “Power Manager \(PM\)” on page 677](#).

6.3.1 Starting of Clocks

After power-up, the device will be held in a reset state by the power-up circuitry for a short time to allow the power to stabilize throughout the device. After reset, the device will use the System RC Oscillator (RCSYS) as clock source. Refer to [Section 9. “Electrical Characteristics” on page 98](#) for the frequency for this oscillator.

On system start-up, the DFLL and the PLLs are disabled. Only the necessary clocks are active allowing software execution. Refer to [Section 3-6 “Maskable Module Clocks in AT32UC3B.” on page 24](#) to know the list of peripheral clock running.. No clocks have a divided frequency; all parts of the system receive a clock with the same frequency as the System RC Oscillator.

6.3.2 Fetching of Initial Instructions

After reset has been released, the Cortex M4 CPU starts fetching PC and SP values from the reset address, which is 0x00000000. Refer to the ARM Architecture Reference Manual for more information on CPU startup. This address points to the first address in the internal Flash.

The code read from the internal flash is free to configure the clock system and clock sources.

6.4 Power-on-Reset, Brownout and Supply Monitor

The SAM4L embeds four features to monitor, warn, and/or reset the device:

- POR33: Power-on-Reset on VDDANA
- BOD33: Brownout detector on VDDANA
- POR18: Power-on-Reset on VDDCORE
- BOD18: Brownout detector on VDDCORE

Figure 6-6. Supply Monitor Schematic

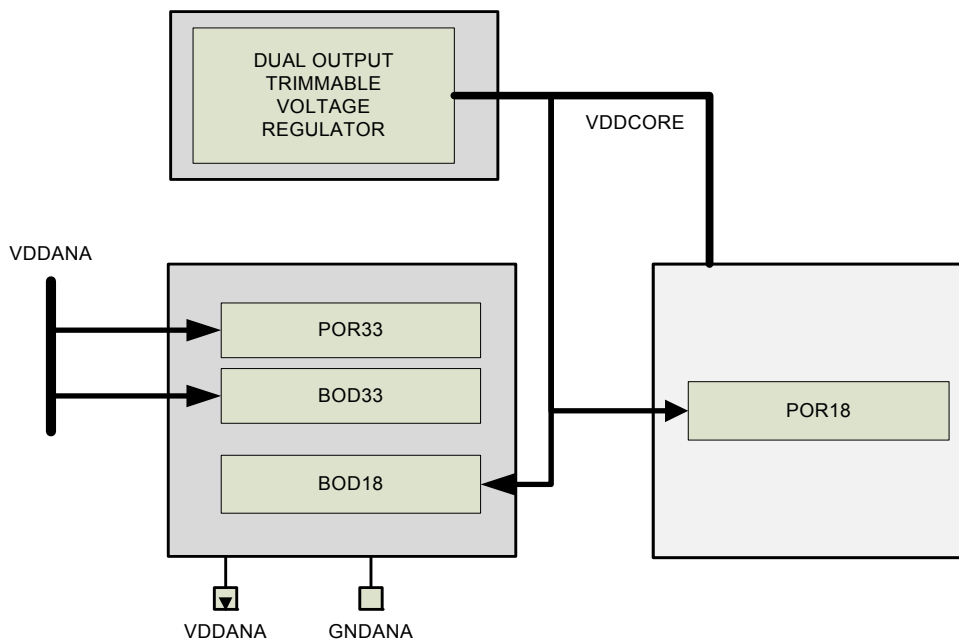

6.4.1 Power-on-Reset on VDDANA

POR33 monitors VDDANA. It is always activated and monitors voltage at startup but also during all the Power Save Mode. If VDDANA goes below the threshold voltage, the entire chip is reset.

6.4.2 Brownout Detector on VDDANA

BOD33 monitors VDDANA. Refer to [Section 15. "Backup System Control Interface \(BSCIF\)" on page 308](#) to get more details.

6.4.3 Power-on-Reset on VDDCORE

POR18 monitors the internal VDDCORE. Refer to [Section 15. "Backup System Control Interface \(BSCIF\)" on page 308](#) to get more details.

6.4.4 Brownout Detector on VDDCORE

Once the device is startup, the BOD18 monitors the internal VDDCORE. Refer to [Section 15. "Backup System Control Interface \(BSCIF\)" on page 308](#) to get more details.

7. Low Power Techniques

The ATSAM4L8/L4/L2 supports multiple power configurations to allow the user to optimize its power consumption in different use cases. The Backup Power Manager (BPM) implements different solutions to reduce the power consumption:

- The Power Save modes intended to reduce the logic activity and to adapt the power configuration. See "Power Save Modes" on page 54.
- The Power Scaling intended to scale the power configuration (voltage scaling of the regulator). See "Power Scaling" on page 59.

These two techniques can be combined together.

Figure 7-1. Power Scaling and Power Save Mode Overview

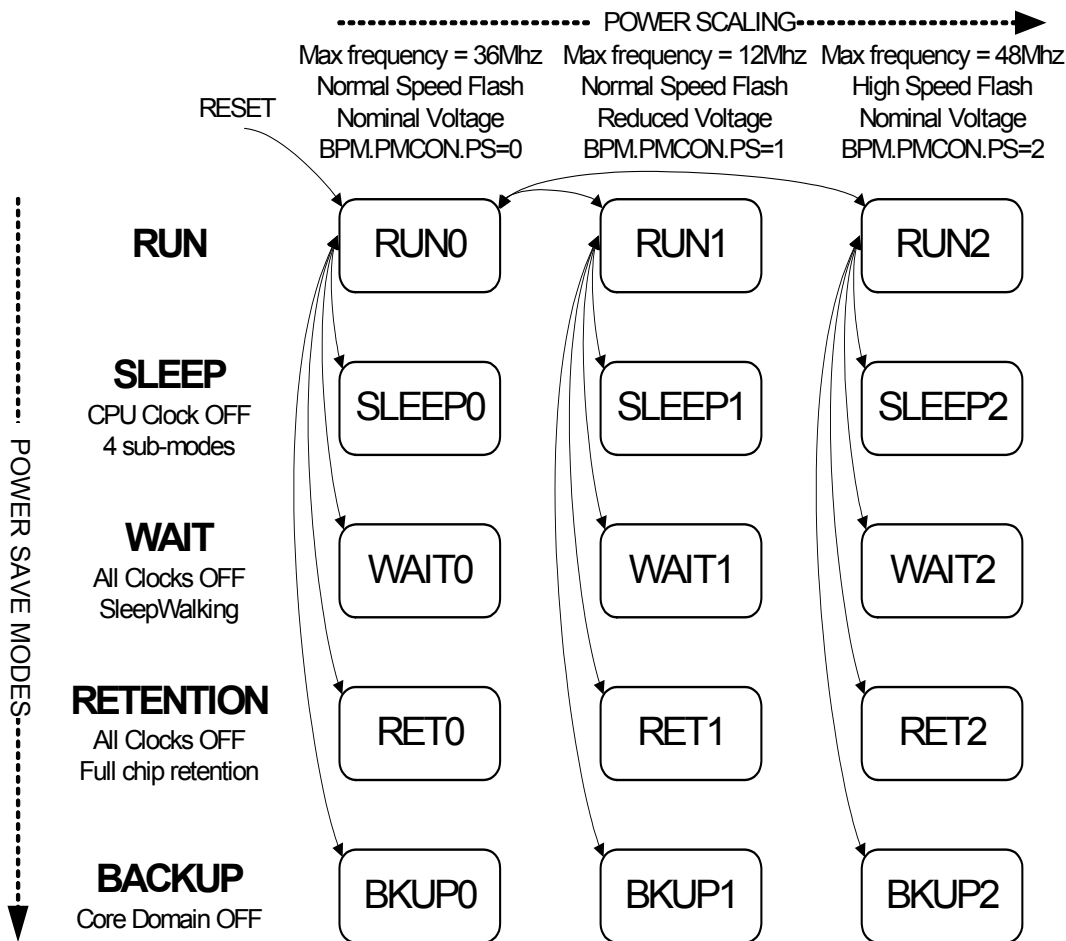

7.1 Power Save Modes

Refer to Section 6. "Power and Startup Considerations" on page 45 to get definition of the core and the backup domains.

At power-up or after a reset, the ATSAM4L8/L4/L2 is in the RUN0 mode. Only the necessary clocks are enabled allowing software execution. The Power Manager (PM) can be used to adjust the clock frequencies and to enable and disable the peripheral clocks.

When the CPU is entering a Power Save Mode, the CPU stops executing code. The user can choose between four Power Save Modes to optimize power consumption:

- SLEEP mode: the Cortex-M4 core is stopped, optionally some clocks are stopped, peripherals are kept running if enabled by the user.
- WAIT mode: all clock sources are stopped, the core and all the peripherals are stopped except the modules running with the 32kHz clock if enabled. This is the lowest power configuration where SleepWalking is supported.
- RETENTION mode: similar to the WAIT mode in terms of clock activity. This is the lowest power configuration where the logic is retained.
- BACKUP mode: the Core domain is powered off, the Backup domain is kept powered.

A wake up source exits the system to the RUN mode from which the Power Save Mode was entered.

A reset source always exits the system from the Power Save Mode to the RUN0 mode.

The configuration of the I/O lines are maintained in all Power Save Modes. Refer to [Section 9. "Backup Power Manager \(BPM\)" on page 677](#).

7.1.1 SLEEP mode

The SLEEP mode allows power optimization with the fastest wake up time.

The CPU is stopped. To further reduce power consumption, the user can switch off modules-clocks and synchronous clock sources through the BPM.PMCON.SLEEP field (See [Table 7-1](#)). The required modules will be halted regardless of the bit settings of the mask registers in the Power Manager (PM.AHBMASK, PM.APBxMASK).

Table 7-1. SLEEP mode Configuration

BPM.PSAVE.SLEEP	CPU clock	AHB clocks	APB clocks GCLK	Clock sources: OSC, RCFast, RC80M, PLL, DFLL	RCSYS	OSC32K RC32K ⁽²⁾	Wake up Sources
0	Stop	Run	Run	Run	Run	Run	Any interrupt
1	Stop	Stop	Run	Run	Run	Run	Any interrupt ⁽¹⁾
2	Stop	Stop	Stop	Run	Run	Run	Any interrupt ⁽¹⁾
3	Stop	Stop	Stop	Stop	Run	Run	Any interrupt ⁽¹⁾

- Notes:
1. from modules with clock running.
 2. OSC32K and RC32K will only remain operational if pre-enabled.

7.1.1.1 Entering SLEEP mode

The SLEEP mode is entered by executing the WFI instruction.

Additionally, if the SLEEPONEXIT bit in the Cortex-M4 System Control Register (SCR) is set, the SLEEP mode will also be entered when the Cortex-M4 exits the lowest priority ISR. This

mechanism can be useful for applications that only require the processor to run when an interrupt occurs.

Before entering the SLEEP mode, the user must configure:

- the SLEEP mode configuration field (BPM.PMCON.SLEEP), Refer to [Table 7-1](#).
- the SCR.SLEEPDEEP bit to 0. (See the Power Management section in the ARM Cortex-M4 Processor chapter).
- the BPM.PMCON.RET bit to 0.
- the BPM.PMCON.BKUP bit to 0.

7.1.1.2 *Exiting SLEEP mode*

The NVIC wakes the system up when it detects any non-masked interrupt with sufficient priority to cause exception entry. The system goes back to the RUN mode from which the SLEEP mode was entered. The CPU and affected modules are restarted. Note that even if an interrupt is enabled in SLEEP mode, it will not trigger if the source module is not clocked.

7.1.2 **WAIT Mode and RETENTION Mode**

The WAIT and RETENTION modes allow achieving very low power consumption while maintaining the Core domain powered-on. Internal SRAM and registers contents of the Core domain are preserved.

In these modes, all clocks are stopped except the 32kHz clocks (OSC32K, RC32K) which are kept running if enabled.

In RETENTION mode, the SleepWalking feature is not supported and must not be used.

7.1.2.1 *Entering WAIT or RETENTION Mode*

The WAIT or RETENTION modes are entered by executing the WFI instruction with the following settings:

- set the SCR.SLEEPDEEP bit to 1. (See the Power Management section in the ARM Cortex-M4 Processor chapter).
- set the BPM.PSAVE.BKUP bit to 0.
- set the BPM.PMCON.RET bit to RETENTION or WAIT mode.

SLEEPONEXIT feature is also available. See ["Entering SLEEP mode" on page 55](#).

7.1.2.2 *Exiting WAIT or RETENTION Mode*

In WAIT or RETENTION modes, synchronous clocks are stopped preventing interrupt sources from triggering. To wakeup the system, asynchronous wake up sources (AST, EIC, USBC ...) should be enabled in the peripheral (refer to the documentation of the peripheral). The PM.AWEN (Asynchronous Wake Up Enable) register should also be enabled for all peripheral except for EIC and AST.

When the enabled asynchronous wake up event occurs and the system is waken-up, it will generate either:

- an interrupt on the PM WAKE interrupt line if enabled (Refer to [Section 9. "Power Manager \(PM\)" on page 677](#)). In that case, the PM.WCAUSE register indicates the wakeup source.
- or an interrupt directly from the peripheral if enabled (Refer to the section of the peripheral).

When waking up, the system goes back to the RUN mode mode from which the WAIT or RETENTION mode was entered.

7.1.3 BACKUP Mode

The BACKUP mode allows achieving the lowest power consumption possible in a system which is performing periodic wake-ups to perform tasks but not requiring fast startup time.

The Core domain is powered-off. The internal SRAM and register contents of the Core domain are lost. The Backup domain is kept powered-on. The 32kHz clock (RC32K or OSC32K) is kept running if enabled to feed modules that require clocking.

In BACKUP mode, the configuration of the I/O lines is preserved. Refer to [Section 9. "Backup Power Manager \(BPM\)" on page 677](#) to have more details.

7.1.3.1 Entering BACKUP Mode

The Backup mode is entered by using the WFI instruction with the following settings:

- set the SCR.SLEEPDEEP bit to 1. (See the Power Management section in the ARM Cortex-M4 Processor chapter).
- set the BPM.PSAVE.BKUP bit to 1.

7.1.3.2 Exiting BACKUP Mode

Exit from BACKUP mode happens if a reset occurs or if an enabled wake up event occurs.

The reset sources are:

- BOD33 reset
- BOD18 reset
- WDT reset
- External reset in RESET_N pin

The wake up sources are:

- EIC lines (level transition only)
- BOD33 interrupt
- BOD18 interrupt
- AST alarm, periodic, overflow
- WDT interrupt

The RC32K or OSC32K should be used as clock source for modules if required. The PMCON.CK32S is used to select one of these two 32kHz clock sources.

Exiting the BACKUP mode is triggered by:

- a reset source: an internal reset sequence is performed according to the reset source. Once VDDCORE is stable and has the correct value according to RUN0 mode, the internal reset is released and program execution starts. The corresponding reset source is flagged in the Reset Cause register (RCAUSE) of the PM.
- a wake up source: the Backup domain is not reset. An internal reset is generated to the Core domain, and the system switches back to the previous RUN mode. Once VDDCORE is stable and has the correct value, the internal reset in the Core domain is released and program execution starts. The BKUP bit is set in the Reset Cause register (RCAUSE) of the PM. It allows the user to discriminate between the reset cause and a wake up cause from the BACKUP mode. The wake up cause can be found in the Backup Wake up Cause register (BPM.BKUPWCAUSE).

7.1.4 Wakeup Time

7.1.4.1 Wakeup Time From SLEEP Mode

The latency depends on the clock sources wake up time. If the clock sources are not stopped, there is no latency to wake the clocks up.

7.1.4.2 Wakeup Time From WAIT or RETENTION Mode

The wake up latency consists of:

- the switching time from the low power configuration to the RUN mode power configuration. By default, the switching time is completed when all the voltage regulation system is ready. To speed-up the startup time, the user can set the Fast Wakeup bit in BPM.PMCON register.
- the wake up time of the RC oscillator used to start the system up. By default, the RCSYS oscillator is used to startup the system. The user can use another clock source (RCFAST for example) to speed up the startup time by configuring the PM.FASTWKUP register. Refer to [Section 9. "Power Manager \(PM\)" on page 677](#).
- the Flash memory wake up time.

To have the shortest wakeup time, the user should:

- set the BPM.PMCON.FASTWKUP bit.
- configure the PM.FASTSLEEP.FASTRCOSC field to use the RCFAST main clock.
- enter the WAIT or RETENTION mode

Upon a wakeup, this is required to keep the main clock connected to RCFAST until the voltage regulation system is fully ready (when BPM.ISR.PSOK bit is one). During this wakeup period, the FLASHCALW module is automatically configured to operate in "1 wait state mode".

7.1.4.3 Wake time from BACKUP mode

It is equal to the Core domain logic reset latency (similar to the reset latency caused by an external reset in RESET_N pin) added to the time required for the voltage regulation system to be stabilized.

7.1.5 Power Save Mode Summary Table

The following table shows a summary of the main Power Save modes:

Table 7-2. Power Save mode Configuration Summary

Mode	Mode Entry	Wake up sources	Core domain	Backup domain
SLEEP	WFI SCR.SLEEPDEEP bit = 0 BPM.PMCON.BKUP bit = 0	Any interrupt	CPU clock OFF Other clocks OFF depending on the BPM.PMCON.SLEEP field see "SLEEP mode" on page 55	Clocks OFF depending on the BPM.PMCON.SLEEP field see "SLEEP mode" on page 55
WAIT	WFI SCR.SLEEPDEEP bit = 1 BPM.PMCON.RET bit = 0 BPM.PMCON.BKUP bit = 0	PM WAKE interrupt	All clocks are OFF Core domain is retained	All clocks are OFF except RC32K or OSC32K if running
RETENTION	WFI SCR.SLEEPDEEP bit = 1 BPM.PMCON.RET bit = 1 BPM.PMCON.BKUP bit = 0	PM WAKE interrupt	All clocks are OFF Core domain is retained	All clocks are OFF except RC32K or OSC32K if running
BACKUP	WFI + SCR.SLEEPDEEP bit = 1 + BPM.PMCON.BKUP bit = 1	EIC interrupt BOD33, BOD18 interrupt and reset AST alarm, periodic, overflow WDT interrupt and reset external reset on RESET_N pin	OFF (not powered)	All clocks are OFF except RC32K or OSC32K if running

7.2 Power Scaling

The Power Scaling technique consists of adjusting the internal regulator output voltage (voltage scaling) to reduce the power consumption. According to the requirements in terms of performance, operating modes, and current consumption, the user can select the Power Scaling configuration that fits the best with its application.

The Power Scaling configuration field (PMCON.PS) is provided in the Backup Power Manager (BPM) module.

In RUN mode, the user can adjust on the fly the Power Scaling configuration

The [Figure 7.1](#) summarizes the different combination of the Power Scaling configuration which can be applied according to the Power Save Mode.

Power scaling from a current power configuration to a new power configuration is done by halting the CPU execution

Power scaling occurs after a WFI instruction. The system is halted until the new power configuration is stabilized. After handling the PM interrupt, the system resumes from WFI.

To scale the power, the following sequence is required:

- Check the BPM.SR.PSOK bit to make sure the current power configuration is stabilized.

- Set the clock frequency to be supported in both power configurations.
- Set the high speed read mode of the FLASH to be supported in both power scaling configurations
 - Only relevant when entering or exiting BPM.PMCON.PS=2
- Configure the BPM.PMCON.PS field to the new power configuration.
- Set the BPM.PMCON.PSCREQ bit to one.
- Disable all the interrupts except the PM WCAUSE interrupt and enable only the PSOK asynchronous event in the AWEN register of PM.
- Execute the WFI instruction.
- WAIT for PM interrupt.

The new power configuration is reached when the system is waken up by the PM interrupt thanks to the PSOK event.

By default, all features are available in all Power Scaling modes. However some specific features are not available in PS1 (BPM.PMCON.PS=1) mode :

- USB
- DFLL
- PLL
- Programming/Erasing in Flash

8. Debug and Test

8.1 Features

- IEEE1149.1 compliant JTAG Debug Port
- Serial Wire Debug Port
- Boundary-Scan chain on all digital pins for board-level testing
- Direct memory access and programming capabilities through debug ports
- Flash Patch and Breakpoint (FPB) unit for implementing breakpoints and code patches
- Data Watchpoint and Trace (DWT) unit for implementing watchpoints, data tracing, and system profiling
- Instrumentation Trace Macrocell (ITM) for support of printf style debugging
- Chip Erase command and status
- Unlimited Flash User page read access
- Cortex-M4 core reset source
- CRC32 of any memory accessible through the bus matrix
- Debugger Hot Plugging

8.2 Overview

Debug and test features are made available to external tools by:

- The Enhanced Debug Port (EDP) embedding:
 - a Serial Wire Debug Port (SW-DP) part of the ARM coresight architecture
 - an IEEE 1149.1 JTAG Debug Port (JTAG-DP) part of the ARM coresight architecture
 - a supplementary IEEE 1149.1 JTAG TAP machine that implements the boundary scan feature
- The System Manager Access Port (SMAP) providing unlimited flash User page read access, CRC32 of any memory accessible through the bus matrix and Cortex-M4 core reset services
- The AHB Access Port (AHB-AP) providing Direct memory access, programming capabilities and standard debugging functions
- The Instrumentation Trace macrocell part of the ARM coresight architecture

For more information on ARM debug components, please refer to:

- ARMv7-M Architecture Reference Manual
- ARM Debug Interface v5.1 Architecture Specification document
- ARM CoreSight Architecture Specification
- ARM ETM Architecture Specification v3.5
- ARM Cortex-M4 Technical Reference Manual

8.3 Block diagram

Figure 8-1. Debug and Test Block Diagram

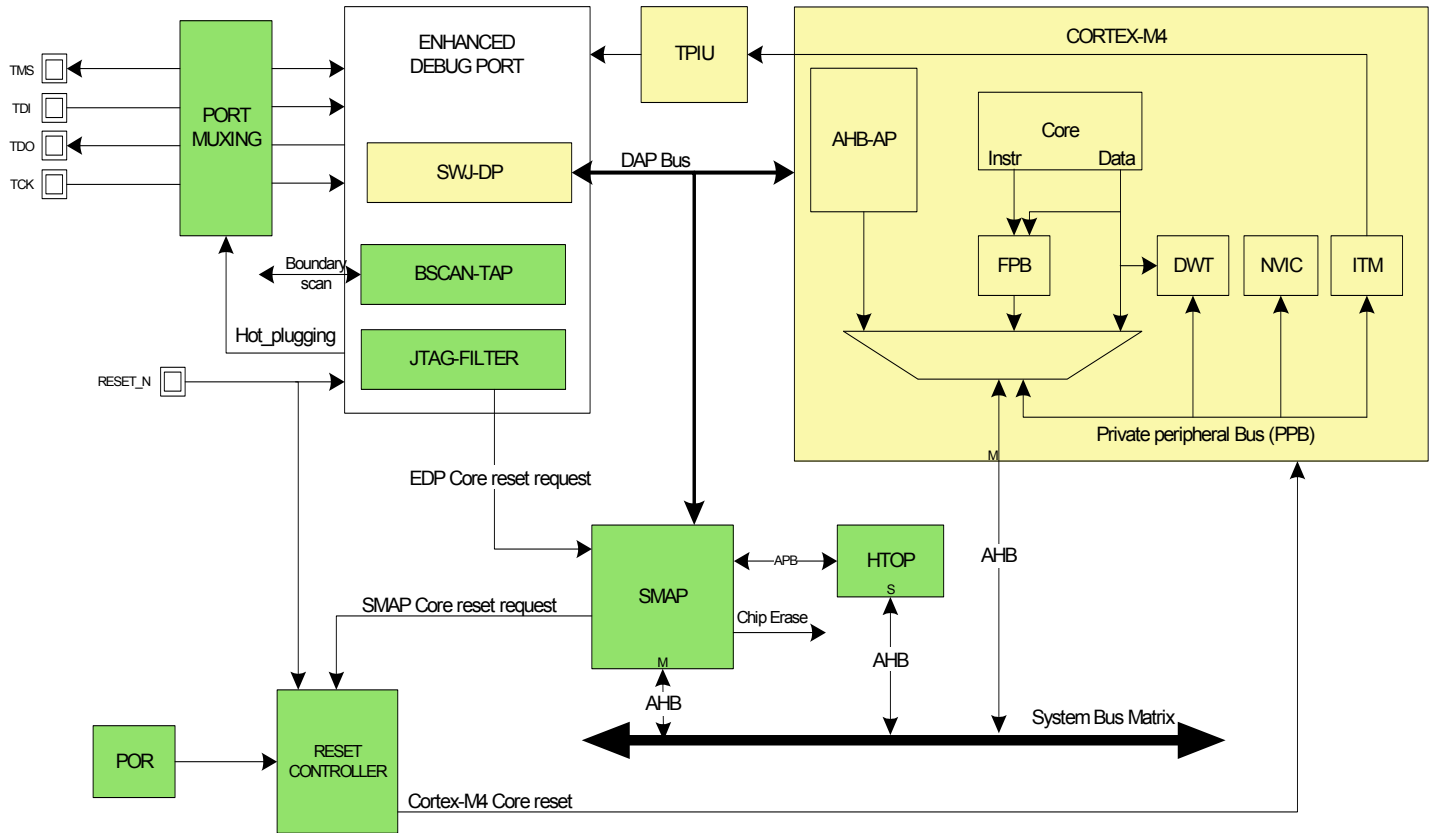

note: Boxes with a plain corner are SAM4L specific.

8.4 I/O Lines Description

Refer to [Section 1.1.4 "I/O Lines Description"](#) on page 4.

8.5 Product dependencies

8.5.1 I/O Lines

Refer to [Section 1.1.5.1 "I/O Lines" on page 5](#).

8.5.2 Power management

Refer to [Section 1.1.5.2 "Power Management" on page 5](#).

8.5.3 Clocks

Refer to [Section 1.1.5.3 "Clocks" on page 5](#).

8.6 Core debug

Figure 8-2 shows the Debug Architecture used in the SAM4L. The Cortex-M4 embeds four functional units for debug:

- FPB (Flash Patch Breakpoint)
- DWT (Data Watchpoint and Trace)
- ITM (Instrumentation Trace Macrocell)
- TPIU (Trace Port Interface Unit)

The debug architecture information that follows is mainly dedicated to developers of SWJ-DP Emulators/Probes and debugging tool vendors for Cortex-M4 based microcontrollers. For further details on SWJ-DP see the Cortex-M4 technical reference manual.

Figure 8-2. Debug Architecture

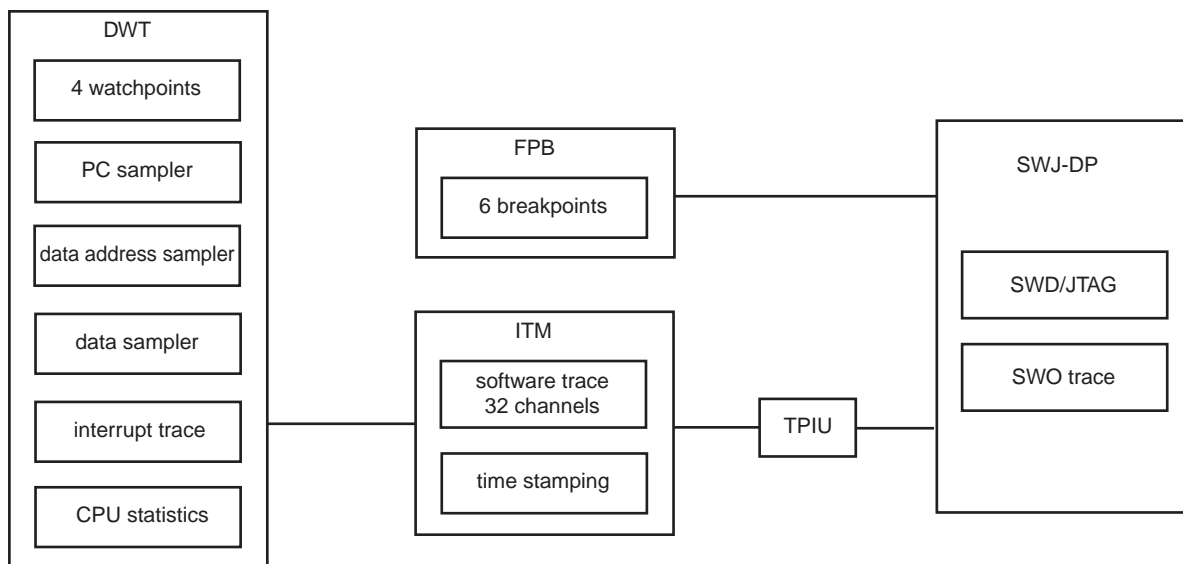

8.6.1 FPB (Flash Patch Breakpoint)

The FPB:

- Implements hardware breakpoints
- Patches (on the fly) code and data being fetched by the Cortex-M4 core from code space with data in the system space. Definition of code and system spaces can be found in the System Address Map section of the ARMv7-M Architecture Reference Manual.

The FPB unit contains:

- Two literal comparators for matching against literal loads from Code space, and remapping to a corresponding area in System space.
- Six instruction comparators for matching against instruction fetches from Code space and remapping to a corresponding area in System space.
- Alternatively, comparators can also be configured to generate a Breakpoint instruction to the processor core on a match.

8.6.2 DWT (Data Watchpoint and Trace)

The DWT contains four comparators which can be configured to generate the following:

- PC sampling packets at set intervals
- PC or Data watchpoint packets
- Watchpoint event to halt core

The DWT contains counters for the items that follow:

- Clock cycle (CYCCNT)
- Folded instructions
- Load Store Unit (LSU) operations
- Sleep Cycles
- CPI (all instruction cycles except for the first cycle)
- Interrupt overhead

8.6.3 ITM (Instrumentation Trace Macrocell)

The ITM is an application driven trace source that supports printf style debugging to trace Operating System (OS) and application events, and emits diagnostic system information. The ITM emits trace information as packets which can be generated by three different sources with several priority levels:

- **Software trace:** This can be done thanks to the printf style debugging. For more information, refer to [Section “How to Configure the ITM:”](#).
- **Hardware trace:** The ITM emits packets generated by the DWT.
- **Time stamping:** Timestamps are emitted relative to packets. The ITM contains a 21-bit counter to generate the timestamp.

How to Configure the ITM:

The following example describes how to output trace data in asynchronous trace mode.

- Configure the TPIU for asynchronous trace mode (refer to [Section “5.4.3. How to Configure the TPIU”](#))
- Enable the write accesses into the ITM registers by writing “0xC5ACCE55” into the Lock Access Register (Address: 0xE000FB0)
- Write 0x00010015 into the Trace Control Register:
 - Enable ITM
 - Enable Synchronization packets
 - Enable SWO behavior

- Fix the ATB ID to 1
- Write 0x1 into the Trace Enable Register:
 - Enable the Stimulus port 0
- Write 0x1 into the Trace Privilege Register:
 - Stimulus port 0 only accessed in privileged mode (Clearing a bit in this register will result in the corresponding stimulus port being accessible in user mode.)
- Write into the Stimulus port 0 register: TPIU (Trace Port Interface Unit)

The TPIU acts as a bridge between the on-chip trace data and the Instruction Trace Macrocell (ITM).

The TPIU formats and transmits trace data off-chip at frequencies asynchronous to the core.

Asynchronous Mode:

The TPIU is configured in asynchronous mode, trace data are output using the single TRACESWO pin. The TRACESWO signal is multiplexed with the TDO signal of the JTAG Debug Port. As a consequence, asynchronous trace mode is only available when the Serial Wire Debug mode is selected since TDO signal is used in JTAG debug mode.

Two encoding formats are available for the single pin output:

- Manchester encoded stream. This is the reset value.
- NRZ_based UART byte structure

5.4.3. How to Configure the TPIU

This example only concerns the asynchronous trace mode.

- Set the TRCENA bit to 1 into the Debug Exception and Monitor Register (0xE00EDFC) to enable the use of trace and debug blocks.
- Write 0x2 into the Selected Pin Protocol Register
 - Select the Serial Wire Output – NRZ
- Write 0x100 into the Formatter and Flush Control Register
- Set the suitable clock prescaler value into the Async Clock Prescaler Register to scale the baud rate of the asynchronous output (this can be done automatically by the debugging tool).

8.7 Enhanced Debug Port (EDP)

Rev.: 1.0.0.0

8.7.1 Features

- IEEE1149.1 compliant JTAG debug port
- Serial Wire Debug Port
- Boundary-Scan chain on all digital pins for board-level testing
- Debugger Hot-Plugging
- SMAP core reset request source

8.7.2 Overview

The enhanced debug port embeds a standard ARM debug port plus some specific hardware intended for testability and activation of the debug port features. All the information related to the ARM Debug Interface implementation can be found in the ARM Debug Interface v5.1 Architecture Specification document.

It features:

- A single Debug Port (SWJ-DP), that provides the external physical connection to the interface and supports two DP implementations:
 - the JTAG Debug Port (JTAG-DP)
 - the Serial Wire Debug Port (SW-DP)
- A supplementary JTAG TAP (BSCAN-TAP) connected in parallel with the JTAG-DP that implements the boundary scan instructions detailed in
- A JTAG-FILTER module that monitors TCK and RESET_N pins to handle specific features like the detection of a debugger hot-plugging and the request of reset of the Cortex-M4 at startup.

The JTAG-FILTER module detects the presence of a debugger. When present, JTAG pins are automatically assigned to the Enhanced Debug Port(EDP). If the SWJ-DP is switched to the SW mode, then TDI and TDO alternate functions are released. The JTAG-FILTER also implements a CPU halt mechanism. When triggered, the Cortex-M4 is maintained under reset after the external reset is released to prevent any system corruption during later programming operations.

8.7.3 Block Diagram

Figure 8-3. Enhanced Debug Port Block Diagram

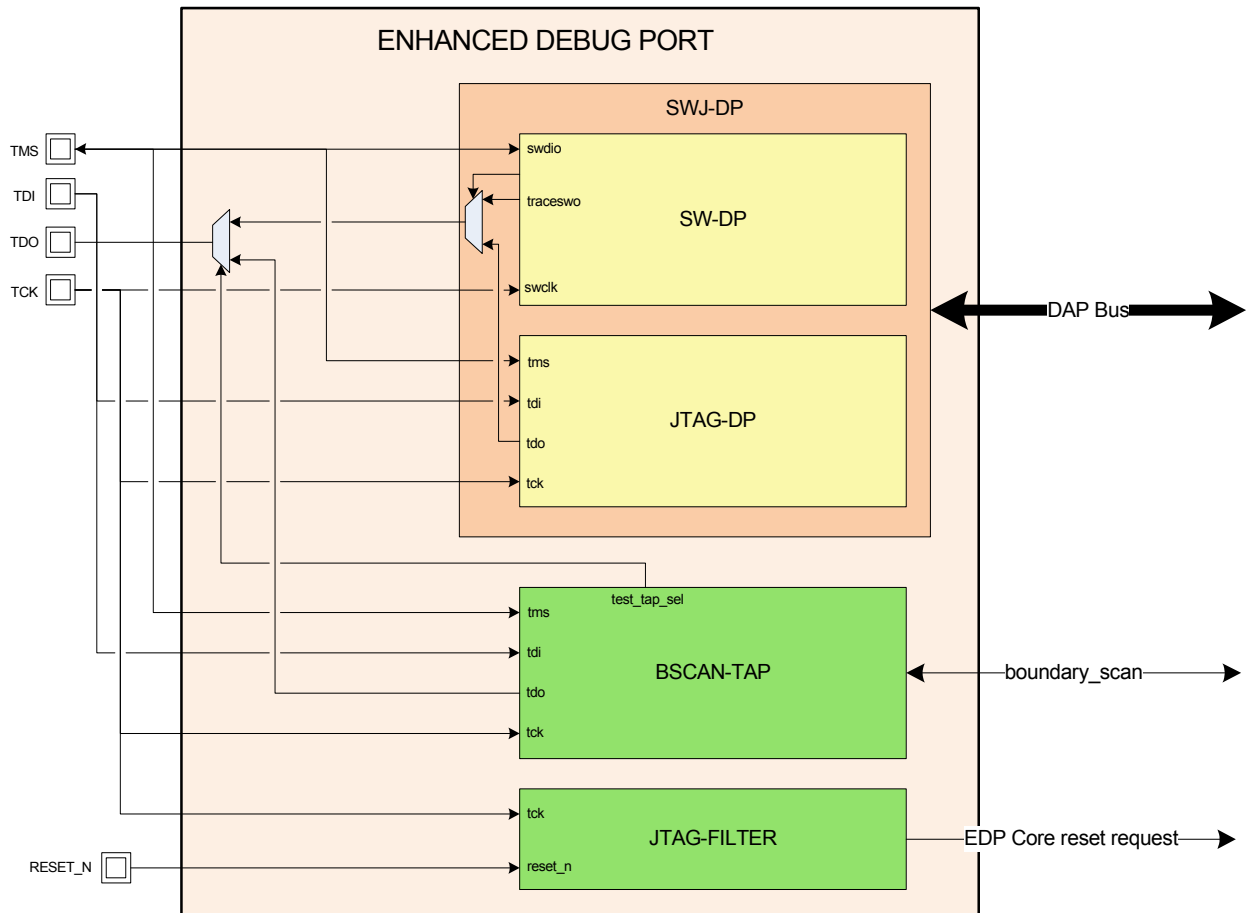

8.7.4 I/O Lines Description

Table 8-1. I/O Lines Description

Name	JTAG Debug Port		SWD Debug Port	
	Type	Description	Type	Description
TCK/SWCLK	I	Debug Clock	I	Serial Wire Clock
TDI	I	Debug Data in	-	NA
TDO/TRACESWO	O	Debug Data Out	O	Trace asynchronous Data Out
TMS/SWDIO	I	Debug Mode Select	I/O	Serial Wire Input/Output
RESET_N	I	Reset	I	Reset

8.7.5 Product Dependencies

8.7.5.1 I/O Lines

The TCK pin is dedicated to the EDP. The other debug port pins default after reset to their GPIO functionality and are automatically reassigned to the JTAG functionalities on detection of a debugger. In serial wire mode, TDI and TDO can be used as GPIO functions. Note that in serial wire mode TDO can be used as a single pin trace output.

8.7.5.2 Power Management

When a debugger is present, the connection is kept alive allowing debug operations. As a side effect, the power is never turned off. The hot plugging functionality is always available except when the system is in BACKUP Power Save Mode.

8.7.5.3 Clocks

The SWJ-DP uses the external TCK pin as its clock source. This clock must be provided by the external JTAG master device.

Some of the JTAG Instructions are used to access an Access Port (SMAP or AHB-AP). These instructions require the CPU clock to be running.

If the CPU clock is not present because the CPU is in a Power Save Mode where this clock is not provided, the Power Manager(PM) will automatically restore the CPU clock on detection of a debug access.

The RCSYS clock is used as CPU clock when the external reset is applied to ensure correct Access Port operations.

8.7.6 Module Initialization

This module is enabled as soon as a TCK falling edge is detected when RESET_N is not asserted (refer to [Section 8.7.7](#) below). Moreover, the module is synchronously reseted as long as the TAP machine is in the TEST_LOGIC_RESET (TLR) state. It is advised asserting TMS at least 5 TCK clock periods after the debugger has been detected to ensure the module is in the TLR state prior to any operation. This module also has the ability to maintain the Cortex-M4 under reset (refer to the [Section 8.7.8 "SMAP Core Reset Request Source" on page 69](#)).

8.7.7 Debugger Hot Plugging

The TCK pin is dedicated to the EDP. After reset has been released, the EDP detects that a debugger has been attached when a TCK falling edge arises.

Figure 8-4. Debugger Hot Plugging Detection Timings Diagram

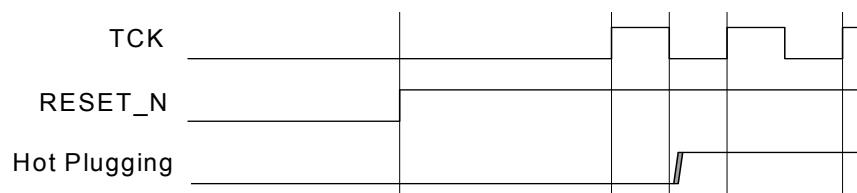

The Debug Port pins assignment is then forced to the EDP function even if they were already assigned to another module. This allows to connect a debugger at any time without resetting the device. The connection is non-intrusive meaning that the chip will continue its execution without being disturbed. The CPU can of course be halted later on by issuing Cortex-M4 OCD features.

8.7.8 SMAP Core Reset Request Source

The EDP has the ability to send a request to the SMAP for a Cortex-M4 Core reset. The procedure to do so is to hold TCK low until RESET_N is released. This mechanism aims at halting the CPU to prevent it from changing the system configuration while the SMAP is operating.

Figure 8-5. SMAP Core Reset Request Timings Diagram

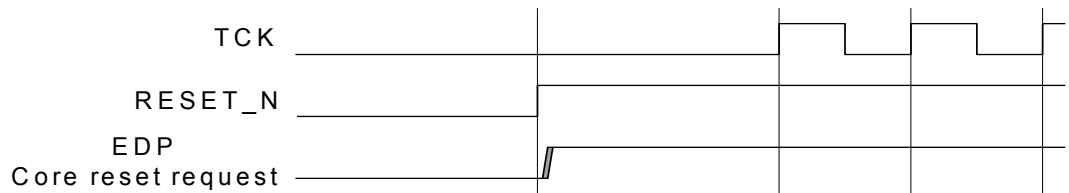

The SMAP can de-assert the core reset request for this operation, refer to [Section 2.8.8 "Cortex-M4 Core Reset Source"](#) on page 57.

8.7.9 SWJ-DP

The Cortex-M4 embeds a SWJ-DP Debug port which is the standard CoreSight™ debug port. It combines Serial Wire Debug Port (SW-DP), from 2 to 3 pins and JTAG debug Port(JTAG-DP), 5 pins.

By default, the JTAG Debug Port is active. If the host debugger wants to switch to the Serial Wire Debug Port, it must provide a dedicated JTAG sequence on TMS/SWDIO and TCK/SWCLK which disables JTAG-DP and enables SW-DP.

When the EDP has been switched to Serial Wire mode, TDO/TRACESWO can be used for trace (for more information refer to the section below). The asynchronous TRACE output (TRACESWO) is multiplexed with TDO. So the asynchronous trace can only be used with SW-DP, not JTAG-DP.

The SWJ-DP provides access to the AHB-AP and SMAP access ports which have the following APSEL value:

Figure 8-6. Access Ports APSEL

Access Port (AP)	APSEL
AHB-AP	0
SMAP	1

Refer to the ARM Debug Interface v5.1 Architecture Specification for more details on SWJ-DP.

8.7.10 SW-DP and JTAG-DP Selection Mechanism

After reset, the SWJ-DP is in JTAG mode but it can be switched to the Serial Wire mode. Debug port selection mechanism is done by sending specific **SWDIOTMS** sequence. The JTAG-DP is selected by default after reset.

- Switch from JTAG-DP to SW-DP. The sequence is:
 - Send more than 50 **SWCLKTCK** cycles with **SWDIOTMS** = 1
 - Send the 16-bit sequence on **SWDIOTMS** = 0111100111100111 (0x79E7 MSB first)
 - Send more than 50 **SWCLKTCK** cycles with **SWDIOTMS** = 1
- Switch from SWD to JTAG. The sequence is:
 - Send more than 50 **SWCLKTCK** cycles with **SWDIOTMS** = 1
 - Send the 16-bit sequence on **SWDIOTMS** = 0011110011100111 (0x3CE7 MSB first)

Send more than 50 **SWCLKTCK** cycles with **SWDIOTMS** = 1

Note that the BSCAN-TAP is not available when the debug port is switched to Serial Mode. Boundary scan instructions are not available.

8.7.11 JTAG-DP and BSCAN-TAP Selection Mechanism

After the DP has been enabled, the BSCAN-TAP and the JTAG-DP run simultaneously as long as the SWJ-DP remains in JTAG mode. Each TAP captures simultaneously the JTAG instructions that are shifted. If an instruction is recognized by the BSCAN-TAP, then the BSCAN-TAP TDO is selected instead of the SWJ-DP TDO. TDO selection changes dynamically depending on the current instruction held in the BSCAN-TAP instruction register.

8.7.12 JTAG Instructions Summary

The implemented JTAG instructions are shown in the table below.

Table 8-2. Implemented JTAG instructions list

IR instruction value	Instruction	Description	availability when protected	Component
b0000	EXTEST	Select boundary-scan chain as data register for testing circuitry external to the device.	yes	BSCAN-TAP
b0001	SAMPLE_PRELOAD	Take a snapshot of external pin values without affecting system operation.	yes	
b0100	INTEST	Select boundary-scan chain for internal testing of the device.	yes	
b0101	CLAMP	Bypass device through Bypass register, while driving outputs from boundary-scan register.	yes	
b1000	ABORT	ARM JTAG-DP Instruction	yes	SWJ-DP (in JTAG mode)
b1010	DPACC	ARM JTAG-DP Instruction	yes	
b1011	APACC	ARM JTAG-DP Instruction	yes	
b1100	-	Reserved	yes	
b1101	-	Reserved	yes	
b1110	IDCODE	ARM JTAG-DP Instruction	yes	
b1111	BYPASS	Bypass this device through the bypass register.	yes	

8.7.13 Security Restrictions

The SAM4L provide a security restrictions mechanism to lock access to the device. The device in the protected state when the Flash Security Bit is set. Refer to section Flash Controller for more details.

When the device is in the protected state the AHB-AP is locked. Full access to the AHB-AP is re-enabled when the protected state is released by issuing a Chip Erase command. Note that the protected state will read as programmed only after the system has been reseted.

8.7.13.1 Notation

Table 8-4 on page 72 shows bit patterns to be shifted in a format like "**p01**". Each character corresponds to one bit, and eight bits are grouped together for readability. The least significant bit is always shifted first, and the most significant bit shifted last. The symbols used are shown in Table 8-3.

Table 8-3. Symbol Description

Symbol	Description
0	Constant low value - always reads as zero.
1	Constant high value - always reads as one.
p	The chip protected state.
x	A don't care bit. Any value can be shifted in, and output data should be ignored.
e	An error bit. Read as one if an error occurred, or zero if not.
b	A busy bit. Read as one if the SMAP was busy, or zero if it was not.
s	Startup done bit. Read as one if the system has started-up correctly.

In many cases, it is not required to shift all bits through the data register. Bit patterns are shown using the full width of the shift register, but the suggested or required bits are emphasized using **bold** text. I.e. given the pattern "**01010101** xxxxxxxx xxxxxxxx xxxxxxxx", the shift register is 32 bits, but the test or debug unit may choose to shift only 8 bits "**01010101**".

The following describes how to interpret the fields in the instruction description tables:

Table 8-4. Instruction Description

Instruction	Description
IR input value	Shows the bit pattern to shift into IR in the Shift-IR state in order to select this instruction. The pattern is show both in binary and in hexadecimal form for convenience. Example: 1000 (0x8)
IR output value	Shows the bit pattern shifted out of IR in the Shift-IR state when this instruction is active. Example: p00s

Table 8-4. Instruction Description (Continued)

Instruction	Description
DR Size	Shows the number of bits in the data register chain when this instruction is active. Example: 32 bits
DR input value	Shows which bit pattern to shift into the data register in the Shift-DR state when this instruction is active.
DR output value	Shows the bit pattern shifted out of the data register in the Shift-DR state when this instruction is active.

8.7.14 JTAG Instructions

Refer to the ARM Debug Interface v5.1 Architecture Specification for more details on ABORT, DPACC, APACC and IDCODE instructions.

8.7.14.1 EXTEST

This instruction selects the boundary-scan chain as Data Register for testing circuitry external to the chip package. The contents of the latched outputs of the boundary-scan chain is driven out as soon as the JTAG IR-register is loaded with the EXTEST instruction.

Starting in Run-Test/Idle, the EXTEST instruction is accessed the following way:

1. Select the IR Scan path.
2. In Capture-IR: The IR output value is latched into the shift register.
3. In Shift-IR: The instruction register is shifted by the TCK input.
4. In Update-IR: The data from the boundary-scan chain is applied to the output pins.
5. Return to Run-Test/Idle.
6. Select the DR Scan path.
7. In Capture-DR: The data on the external pins is sampled into the boundary-scan chain.
8. In Shift-DR: The boundary-scan chain is shifted by the TCK input.
9. In Update-DR: The data from the scan chain is applied to the output pins.
10. Return to Run-Test/Idle.

Table 8-5. EXTEST Details

Instructions	Details
IR input value	0000 (0x0)
IR output value	p00s
DR Size	Depending on boundary-scan chain, see BSDL-file.
DR input value	Depending on boundary-scan chain, see BSDL-file.
DR output value	Depending on boundary-scan chain, see BSDL-file.

8.7.14.2 SAMPLE_PRELOAD

This instruction takes a snap-shot of the input/output pins without affecting the system operation, and pre-loading the scan chain without updating the DR-latch. The boundary-scan chain is selected as Data Register.

Starting in Run-Test/Idle, the Device Identification register is accessed in the following way:

1. Select the IR Scan path.
2. In Capture-IR: The IR output value is latched into the shift register.
3. In Shift-IR: The instruction register is shifted by the TCK input.
4. Return to Run-Test/Idle.
5. Select the DR Scan path.
6. In Capture-DR: The Data on the external pins are sampled into the boundary-scan chain.
7. In Shift-DR: The boundary-scan chain is shifted by the TCK input.
8. Return to Run-Test/Idle.

Table 8-6. SAMPLE_PRELOAD Details

Instructions	Details
IR input value	0001 (0x1)
IR output value	p00s
DR Size	Depending on boundary-scan chain, see BSDL-file.
DR input value	Depending on boundary-scan chain, see BSDL-file.
DR output value	Depending on boundary-scan chain, see BSDL-file.

8.7.14.3 INTEST

This instruction selects the boundary-scan chain as Data Register for testing internal logic in the device. The logic inputs are determined by the boundary-scan chain, and the logic outputs are captured by the boundary-scan chain. The device output pins are driven from the boundary-scan chain.

Starting in Run-Test/Idle, the INTEST instruction is accessed the following way:

1. Select the IR Scan path.
2. In Capture-IR: The IR output value is latched into the shift register.
3. In Shift-IR: The instruction register is shifted by the TCK input.
4. In Update-IR: The data from the boundary-scan chain is applied to the internal logic inputs.
5. Return to Run-Test/Idle.
6. Select the DR Scan path.
7. In Capture-DR: The data on the internal logic is sampled into the boundary-scan chain.
8. In Shift-DR: The boundary-scan chain is shifted by the TCK input.
9. In Update-DR: The data from the boundary-scan chain is applied to internal logic inputs.
10. Return to Run-Test/Idle.

Table 8-7. INTEST Details

Instructions	Details
IR input value	0100 (0x4)
IR output value	p001
DR Size	Depending on boundary-scan chain, see BSDL-file.
DR input value	Depending on boundary-scan chain, see BSDL-file.
DR output value	Depending on boundary-scan chain, see BSDL-file.

8.7.14.4 CLAMP

This instruction selects the Bypass register as Data Register. The device output pins are driven from the boundary-scan chain.

Starting in Run-Test/Idle, the CLAMP instruction is accessed the following way:

1. Select the IR Scan path.
2. In Capture-IR: The IR output value is latched into the shift register.
3. In Shift-IR: The instruction register is shifted by the TCK input.
4. In Update-IR: The data from the boundary-scan chain is applied to the output pins.
5. Return to Run-Test/Idle.
6. Select the DR Scan path.
7. In Capture-DR: A logic '0' is loaded into the Bypass Register.
8. In Shift-DR: Data is scanned from TDI to TDO through the Bypass register.
9. Return to Run-Test/Idle.

Table 8-8. CLAMP Details

Instructions	Details
IR input value	0101 (0x5)
IR output value	p00s
DR Size	1
DR input value	x
DR output value	x

8.8 AHB-AP Access Port

The AHB-AP is a Memory Access Port (MEM-AP) as defined in the ARM Debug Interface v5 Architecture Specification. The AHB-AP provides access to all memory and registers in the system, including processor registers through the System Control Space (SCS). System access is independent of the processor status. Either SW-DP or SWJ-DP is used to access the AHB-AP. The AHB-AP is a master into the Bus Matrix. Transactions are made using the AHB-AP programmers model (please refer to the ARM Cortex-M4 Technical Reference Manual), which generates AHB-Lite transactions into the Bus Matrix. The AHB-AP does not perform back-to-back transactions on the bus, so all transactions are non-sequential. The AHB-AP can perform unaligned and bit-band transactions. The Bus Matrix handles these. The AHB-AP transactions are not subject to MPU lookups. AHB-AP transactions bypass the FPB, and so the FPB cannot remap AHB-AP transactions. AHB-AP transactions are little-endian.

Note that while an external reset is applied, AHB-AP accesses are not possible. In addition, access is denied when the protected state is set. In order to discard the protected state, a chip erase operation is necessary.

8.9 System Manager Access Port (SMAP)

Rev.: 1.0.0.0

8.9.1 Features

- Chip Erase command and status
- Cortex-M4 core reset source
- 32-bit Cyclic Redundancy check of any memory accessible through the bus matrix
- Unlimited Flash User page read access
- Chip identification register

8.9.2 Overview

The SMAP provides memory-related services and also Cortex-M4 core reset control to a debugger through the Debug Port. This makes possible to halt the CPU and program the device after reset.

8.9.3 Block Diagram

Figure 8-7. SMAP Block Diagram

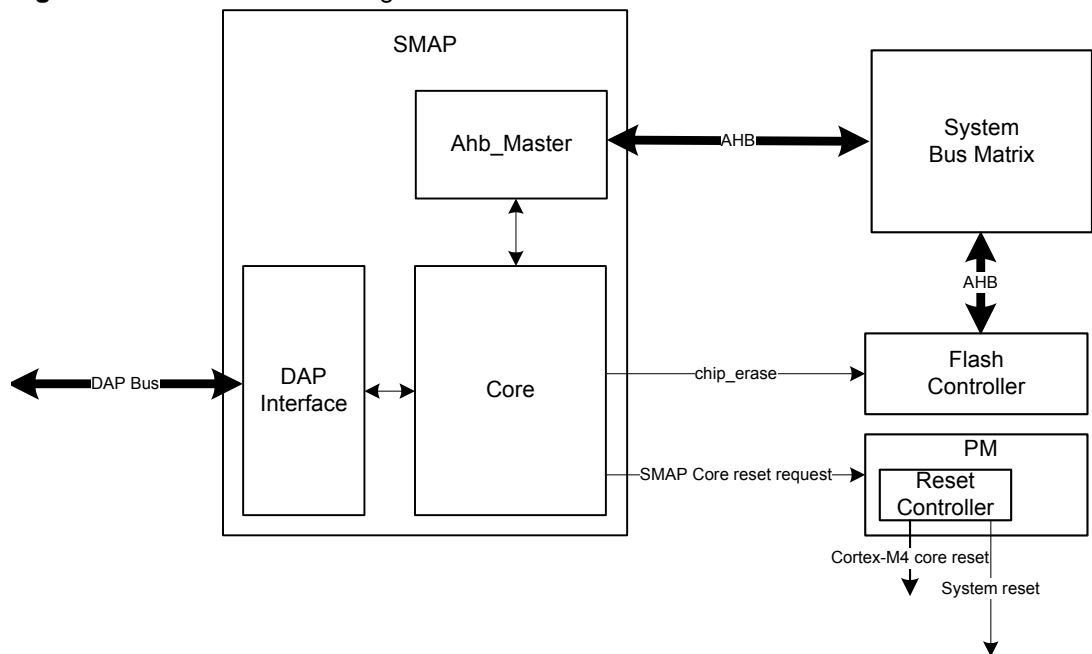

8.9.4 Initializing the Module

The SMAP can be accessed only if the CPU clock is running and the SWJ-DP has been activated by issuing a CDBGPWRUP request. For more details, refer to the ARM Debug Interface v5.1 Architecture Specification.

Then it must be enabled by writing a one to the EN bit of the CR register (CR.EN) before writing or reading other registers. If the SMAP is not enabled it will discard any read or write operation.

8.9.5 Stopping the Module

To stop the module, the user must write a one to the DIS bit of the CR register (CR.DIS). All the user interface and internal registers will be cleared and the internal clock will be stopped.

8.9.6 Security Considerations

In protected state this module may access sensible information located in the device memories. To avoid any risk of sensible data extraction from the module registers, all operations are non interruptible except by a disable command triggered by writing a one to CR.DIS. Issuing this command clears all the interface and internal registers.

Some registers have some special protection:

- It is not possible to read or write the LENGTH register when the part is protected.
- In addition, when the part is protected and an operation is ongoing, it is not possible to read the ADDR and DATA registers. Once an operation has started, the user has to wait until it has terminated by polling the DONE field in the Status Register (SR.DONE).

8.9.7 Chip Erase

The Chip erase operation consists in:

1. clearing all the volatile memories in the system
2. clearing the whole flash array
3. clearing the protected state

No proprietary or sensitive information is left in volatile memories once the protected state is disabled.

This feature is operated by writing a one to the CE bit of the Control Register (CR.CE). When the operation completes, SR.DONE is asserted.

8.9.8 Cortex-M4 Core Reset Source

The SMAP processes the EDP Core hold reset requests (Refer to [Section 1.1.8 "SMAP Core Reset Request Source" on page 6](#)). When requested, it instructs the Power Manager to hold the Cortex-M4 core under reset.

The SMAP can de-assert the core reset request if a one is written to the Hold Core Reset bit in the Status Clear Register (SCR.HCR). This has the effect of releasing the CPU from its reset state. To assert again this signal, a new reset sequence with TCK tied low must be issued.

Note that clearing HCR with this module is only possible when it is enabled, for more information refer to [Section 8.9.4 "Initializing the Module" on page 77](#). Also note that asserting RESET_N automatically clears HCR.

8.9.9 Unlimited Flash User Page Read Access

The SMAP can access the User page even if the protected state is set. Prior to operate such an access, the user should check that the module is not busy by checking that SR.STATE is equal to zero. Once the offset of the word to access inside the page is written in ADDR.ADDR, the read operation can be initiated by writing a one in CR.FSPR. The SR.STATE field will indicate the FSPR state. Addresses written to ADDR.ADDR must be word aligned. Failing to do so will result in unpredictable behavior. The result can be read in the DATA register as soon as SR.DONE rises. The ADDR field is used as an offset in the page, bits outside a page boundary will be silently discarded. The ADDR register is automatically incremented at the end of the read operation making possible to dump consecutive words without writing the next offset into ADDR.ADDR.

8.9.10 32-bit Cyclic Redundancy Check (CRC)

The SMAP unit provides support for calculating a Cyclic Redundancy Check (CRC) value for a memory area. The algorithm used is the industry standard CRC32 algorithm using the generator polynomial 0xEDB88320.

8.9.10.1 Starting CRC Calculation

To calculate CRC for a memory range, the start address must be written into the ADDR register, and the size of the memory range into the LENGTH register. Both the start address and the length must be word aligned.

The initial value used for the CRC calculation must be written to the DATA register. This value will usually be 0xFFFFFFFF, but can be e.g. the result of a previous CRC calculation if generating a common CRC of separate memory blocks.

Once completed, the calculated CRC value can be read out of the DATA register. The read value must be inverted to match standard CRC32 implementations, or kept non-inverted if used as starting point for subsequent CRC calculations.

If the device is in protected state, it is only possible to calculate the CRC of the whole flash array. In most cases this area will be the entire onboard nonvolatile memory. The ADDR, LENGTH, and DATA registers will be forced to predefined values once the CRC operation is started, and user-written values are ignored. This allows the user to verify the contents of a protected device.

The actual test is started by writing a one in CR.CRC. A running CRC operation can be cancelled by disabling the module (write a one in CR.DIS). This has the effect of resetting the module. The module has to be restarted by issuing an enable command (write a one in CR.EN).

8.9.10.2 Interpreting the Results

The user should monitor the SR register (Refer to [Section 8.9.11.2 "Status Register" on page 82](#)). When the operation is completed SR.DONE is set. Then the SR.BERR and SR.FAIL must be read to ensure that no bus error nor functional error occurred.

8.9.11 SMAP User Interface

Table 8-9. SMAP Register Memory Map

Offset	Register	Register Name	Access (unprotected)	Access (protected)	Reset
0x0000	Control Register	CR	Write-Only	Write-Only (partial) ⁽²⁾	0x00000000
0x0004	Status Register	SR	Read-Only	Read-Only	0x00000000
0x0008	Status Clear Register	SCR	Write-Only	Write-Only (partial) ⁽³⁾	0x00000000
0x000C	Address Register	ADDR	Read/Write	Read/Write (partial) ⁽⁴⁾	0x00000000
0x0010	Length Register	LENGTH	Read/Write	denied	0x00000000
0x0014	Data Register	DATA	Read/Write	Read/Write (partial) ⁽⁴⁾	0x00000000
0x0028	VERSION Register	VERSION	Read-Only	Read-Only	-(¹)
0x00F0	Chip ID Register	CIDR	Read-Only	Read-Only	-(¹)
0x00F4	Chip ID Extension Register	EXID	Read-Only	Read-Only	-(¹)
0x00FC	AP Identification register	IDR	Read-Only	Read-Only	0x003E0000

- Note:
1. The reset value for this register is device specific. Refer to the Module Configuration section at the end of this chapter.
 2. CR.MBIST is ignored
 3. SCR.HCR is ignored
 4. Access is not allowed when an operation is ongoing

8.9.11.1 Control Register

Name: CR
Access Type: Write-Only
Offset: 0x00
Reset Value: 0x00000000

31	30	29	28	27	26	25	24
-	-	-	-	-	-	-	-
23	22	21	20	19	18	17	16
-	-	-	-	-	-	-	-
15	14	13	12	11	10	9	8
-	-	-	-	-	-	-	-
7	6	5	4	3	2	1	0
-	-	-	CE	FSPR	CRC	DIS	EN

Writing a zero to a bit in this register has no effect.

- **CE: Chip Erase**

Writing a one to this bit triggers the FLASH Erase All (EA) operation which clears all volatile memories, the whole flash array, the general purpose fuses and the protected state. The Status register DONE field indicates the completion of the operation.

Reading this bit always returns 0

- **FSPR: Flash User Page Read**

Writing a one to this bit triggers a read operation in the User page. The word pointed by the ADDR register in the page is read and written to the DATA register. ADDR is post incremented allowing a burst of reads without modifying ADDR. SR.DONE must be read high prior to reading the DATA register.

Reading this bit always returns 0

- **CRC: Cyclic Redundancy Code**

Writing a one triggers a CRC calculation over a memory area defined by the ADDR and LENGTH registers. Reading this bit always returns 0

Note: This feature is restricted while in protected state

- **DIS: Disable**

Writing a one to this bit disables the module. Disabling the module resets the whole module immediately.

- **EN: Enable**

Writing a one to this bit enables the module.

8.9.11.2 Status Register

Name: SR
Access Type: Read-Only
Offset: 0x04
Reset Value: 0x00000000

31	30	29	28	27	26	25	24
-	-	-	-	-	STATE		
23	22	21	20	19	18	17	16
-	-	-	-	-	-	-	-
15	14	13	12	11	10	9	8
-	-	-	-	-	DBGP	PROT	EN
7	6	5	4	3	2	1	0
-	-	-	LCK	FAIL	BERR	HCR	DONE

- **STATE: State**

Value	State	Description
0	IDLE	Idle state
1	CE	Chip erase operation is ongoing
2	CRC32	CRC32 operation is ongoing
3	FSPR	Flash User Page Read
4-7	-	reserved

- **DBGP: Debugger present**
 - 1: A debugger is present (TCK falling edge detected)
 - 0: No debugger is present
- **PROT: Protected**
 - 1: The protected state is set. The only way to overcome this is to issue a Chip Erase command.
 - 0: The protected state is not set
- **EN: Enabled**
 - 1: The block is in ready for operation
 - 0: the block is disabled. Write operations are not possible until the block is enabled by writing a one in CR.EN.
- **LCK: Lock**
 - 1: An operation could not be performed because chip protected state is on.
 - 0: No security issues have been detected since last clear of this bit
- **FAIL: Failure**
 - 1: The requested operation failed
 - 0: No failure has been detected since last clear of this bit
- **BERR: Bus Error**
 - 1: A bus error occurred due to the inability to access part of the requested memory area.

0: No bus error has been detected since last clear of this bit

- **HCR: Hold Core reset**

1: The Cortex-M4 core is held under reset

0: The Cortex-M4 core is not held under reset

- **DONE: Operation done**

1: At least one operation has terminated since last clear of this field

0: No operation has terminated since last clear of this field

8.9.11.3 Status Clear Register

Name: SCR
Access Type: Write-Only
Offset: 0x08
Reset Value: 0x00000000

31	30	29	28	27	26	25	24
-	-	-	-	-	-	-	-
23	22	21	20	19	18	17	16
-	-	-	-	-	-	-	-
15	14	13	12	11	10	9	8
-	-	-	-	-	-	-	-
7	6	5	4	3	2	1	0
-	-	-	LCK	FAIL	BERR	HCR	DONE

Writing a zero to a bit in this register has no effect.
 Writing a one to a bit clears the corresponding SR bit

Note: Writing a one to bit HCR while the chip is in protected state has no effect

8.9.11.4 Address Register

Name: ADDR
Access Type: Read/Write
Offset: 0x0C
Reset Value: 0x00000000

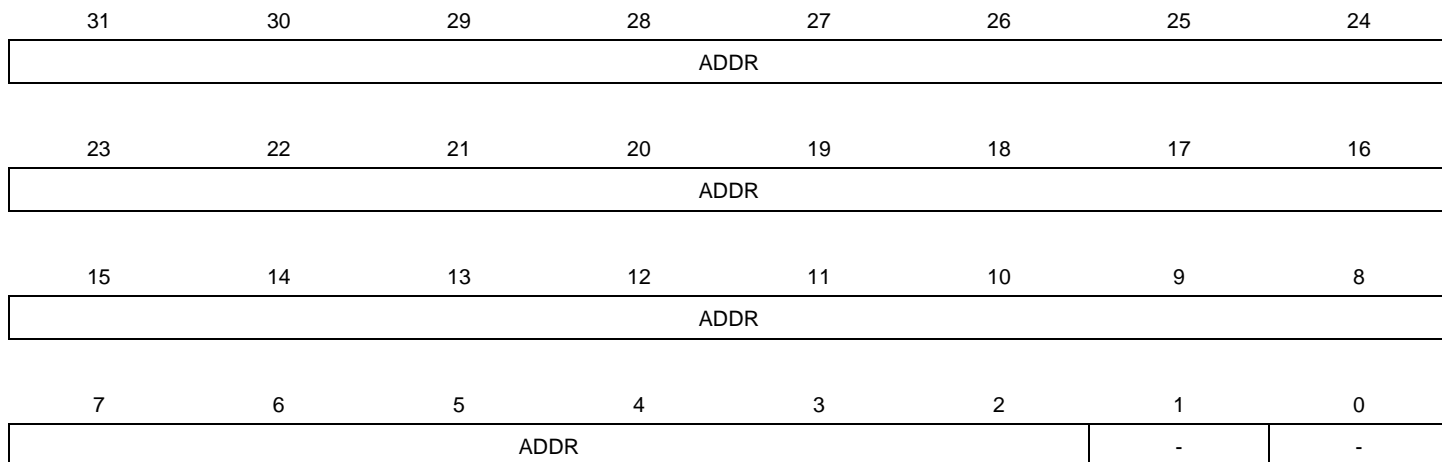

- ADDR: Address Value**
 Address values are always world aligned

8.9.11.5 Length Register

Name: LENGTH
Access Type: Read/Write
Offset: 0x10
Reset Value: 0x00000000

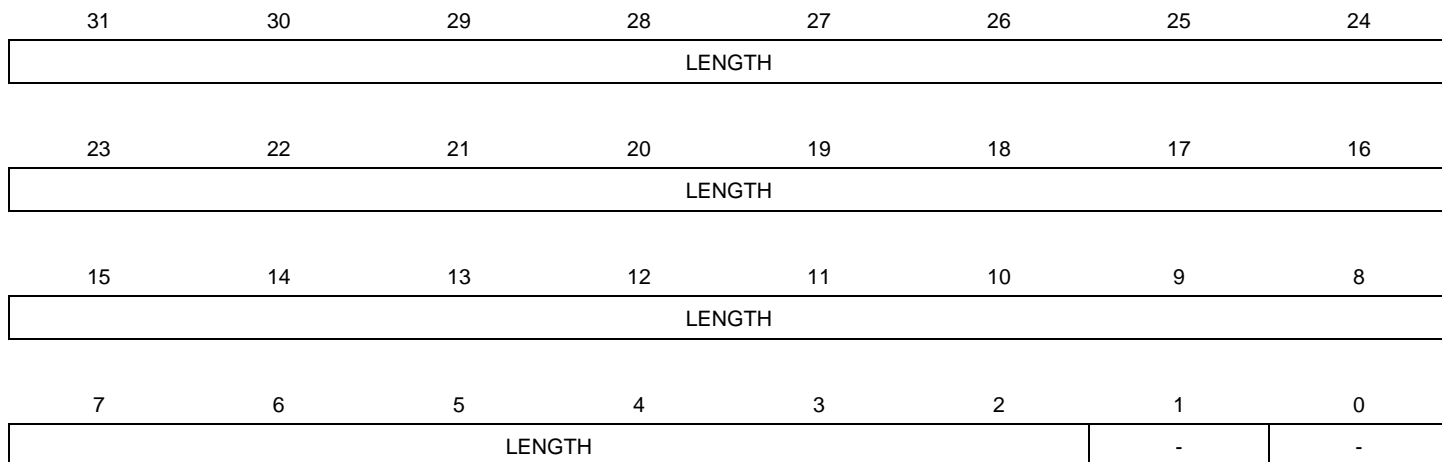

- **LENGTH:** Length Value, Bits 1-0 are always zero

8.9.11.6 Data Register

Name: DATA
Access Type: Read/Write
Offset: 0x14
Reset Value: 0x00000000

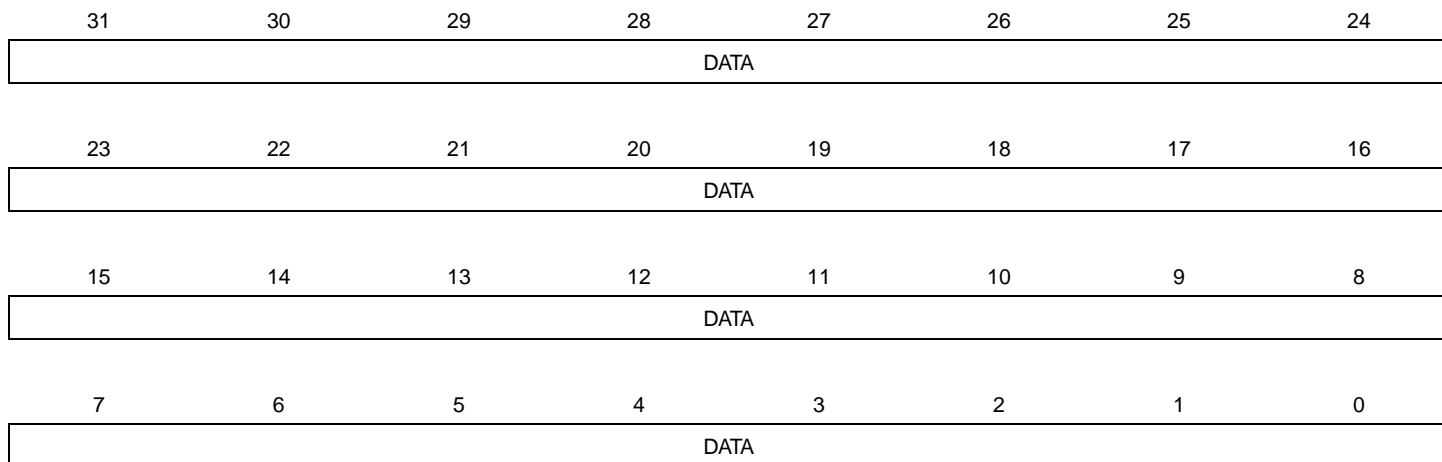

- **DATA:** Generic data register

8.9.11.7 Module Version

Name: VERSION
Access Type: Read-Only
Offset: 0x28
Reset Value: -

31	30	29	28	27	26	25	24
-	-	-	-	-	-	-	-
23	22	21	20	19	18	17	16
-	-	-	-	VARIANT			
15	14	13	12	11	10	9	8
-	-	-	-	VERSION			
7	6	5	4	3	2	1	0
VERSION							

- **VARIANT: Variant number**
Reserved. No functionality associated.
- **VERSION: Version number**
Version number of the module. No functionality associated.

8.9.11.8 Chip Identification Register

Name: CIDR
Access Type: Read-Only
Offset: 0xF0
Reset Value: -



Note: Refer to section CHIPID for more information on this register.

8.9.11.9 Chip Identification Extension Register

Name: EXID
Access Type: Read-Only
Offset: 0xF4
Reset Value: -



Note: Refer to section CHIPID for more information on this register.

8.9.11.10 Identification Register

Name: IDR

Access Type: Read-Only

Offset: 0xFC

Reset Value: -

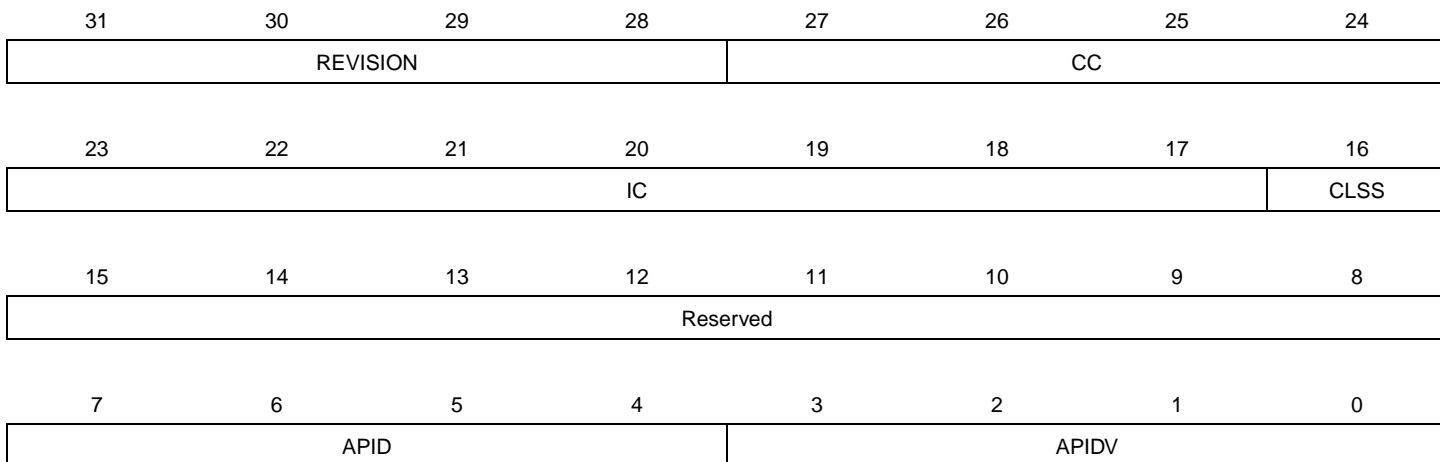

- **REVISION: Revision**
- **CC: JEP-106 Continuation Code**
Atmel continuation code is 0x0
- **IC: JEP-106 Identity Code**
Atmel identification code is 0x1F
- **CLSS: Class**
0: This AP is not a Memory Access Port
1: This AP is a Memory Access Port
- **APID: AP Identification**
- **APIDV: AP Identification Variant**

For more information about this register, refer to the ARM Debug Interface v5.1 Architecture Specification document.

8.10 Available Features in Protected State

Table 8-10. Features availability when in protected state

Feature	Provider	Availability when protected
Hot plugging	EDP	yes
System bus R/W Access	AHB-AP	no
Flash User Page read access	SMAP	yes
Core Hold Reset clear from the SMAP interface	SMAP	no
CRC32 of any memory accessible through the bus matrix	SMAP	restricted (limited to the entire flash array)
Chip Erase	SMAP	yes
IDCODE	SMAP	yes

8.11 Functional Description

8.11.1 Debug Environment

Figure 8-8 shows a complete debug environment example. The SWJ-DP interface is used for standard debugging functions, such as downloading code and single-stepping through the program and viewing core and peripheral registers.

Figure 8-8. Application Debug Environment Example

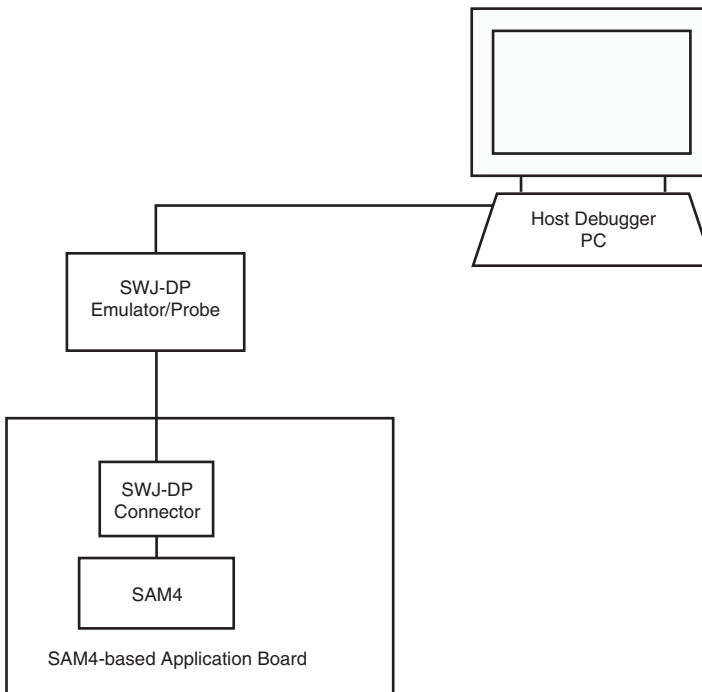

8.11.2 Test Environment

Figure 8-9 shows a test environment example (JTAG Boundary scan). Test vectors are sent and interpreted by the tester. In this example, the “board in test” is designed using a number of JTAG-compliant devices. These devices can be connected to form a single scan chain.

Figure 8-9. Application Test Environment Example

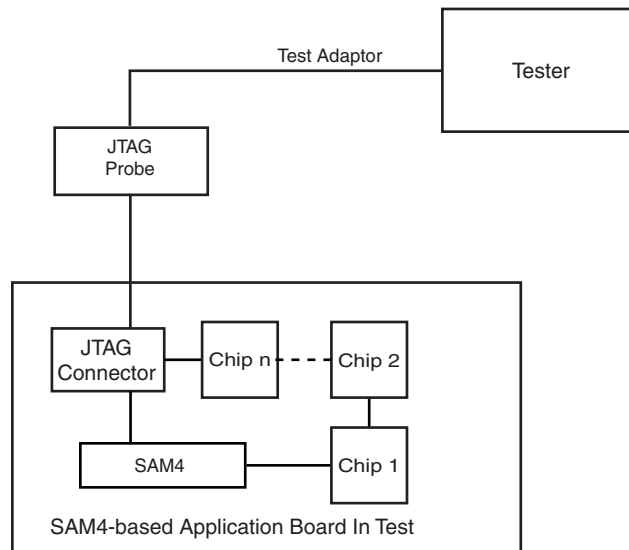

8.11.3 How to initialize test and debug features

To enable the JTAG pins a falling edge event must be detected on the TCK pin at any time after the RESET_N pin is released.

Certain operations requires that the system is prevented from running code after reset is released. This is done by holding low the TCK pin after the RESET_N is released. This makes the SMAP assert the core_hold_reset signal that hold the Cortex-M4 core under reset.

To make the CPU run again, clear the CHR bit in the Status Register (SR.CHR) to de-assert the core_hold_reset signal. Independent of the initial state of the TAP Controller, the Test-Logic-Reset state can always be entered by holding TMS high for 5 TCK clock periods. This sequence should always be applied at the start of a JTAG session and after enabling the JTAG pins to bring the TAP Controller into a defined state before applying JTAG commands. Applying a 0 on TMS for 1 TCK period brings the TAP Controller to the Run-Test/Idle state, which is the starting point for JTAG operations.

8.11.4 How to disable test and debug features

To disable the JTAG pins the TCK pin must be held high while RESET_N pin is released.

8.11.5 Typical JTAG sequence

Assuming Run-Test/Idle is the present state, a typical scenario for using the JTAG interface is:

8.11.5.1 Scanning in JTAG instruction

At the TMS input, apply the sequence 1, 1, 0, 0 at the rising edges of TCK to enter the Shift Instruction Register - Shift-IR state. While in this state, shift the 4 bits of the JTAG instructions into the JTAG instruction register from the TDI input at the rising edge of TCK. The TMS input must be held low during input of the 4 LSBs in order to remain in the Shift-IR state. The JTAG Instruction selects a particular Data Register as path between TDI and TDO and controls the circuitry surrounding the selected Data Register.

Apply the TMS sequence 1, 1, 0 to re-enter the Run-Test/Idle state. The instruction is latched onto the parallel output from the shift register path in the Update-IR state. The Exit-IR, Pause-IR, and Exit2-IR states are only used for navigating the state machine.

Figure 8-10. Scanning in JTAG instruction

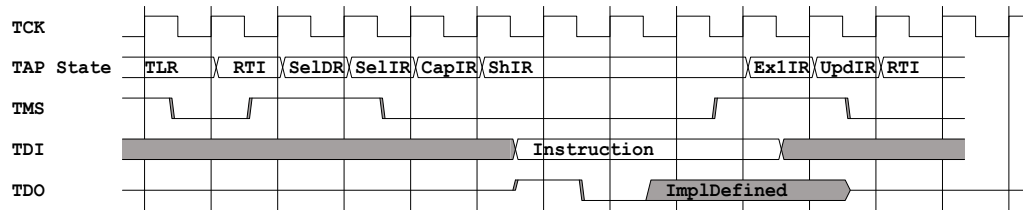

8.11.5.2 Scanning in/out data

At the TMS input, apply the sequence 1, 0, 0 at the rising edges of TCK to enter the Shift Data Register - Shift-DR state. While in this state, upload the selected Data Register (selected by the present JTAG instruction in the JTAG Instruction Register) from the TDI input at the rising edge of TCK. In order to remain in the Shift-DR state, the TMS input must be held low. While the Data Register is shifted in from the TDI pin, the parallel inputs to the Data Register captured in the Capture-DR state is shifted out on the TDO pin.

Apply the TMS sequence 1, 1, 0 to re-enter the Run-Test/Idle state. If the selected Data Register has a latched parallel-output, the latching takes place in the Update-DR state. The Exit-DR, Pause-DR, and Exit2-DR states are only used for navigating the state machine.

As shown in the state diagram, the Run-Test/Idle state need not be entered between selecting JTAG instruction and using Data Registers.

8.11.6 Boundary-Scan

The Boundary-Scan chain has the capability of driving and observing the logic levels on the digital I/O pins, as well as the boundary between digital and analog logic for analog circuitry having off-chip connections. At system level, all ICs having JTAG capabilities are connected serially by the TDI/TDO signals to form a long shift register. An external controller sets up the devices to drive values at their output pins, and observe the input values received from other devices. The controller compares the received data with the expected result. In this way, Boundary-Scan provides a mechanism for testing interconnections and integrity of components on Printed Circuit Boards by using the 4 TAP signals only.

The four IEEE 1149.1 defined mandatory JTAG instructions IDCODE, BYPASS, SAMPLE/PRELOAD, and EXTEST can be used for testing the Printed Circuit Board. Initial scanning of the data register path will show the ID-code of the device, since IDCODE is the default JTAG instruction. It may be desirable to have the device in reset during test mode. If not reset, inputs to the device may be determined by the scan operations, and the internal software may be in an undetermined state when exiting the test mode. Entering reset, the outputs of any Port Pin will instantly enter the high impedance state, making the HIGHZ instruction redundant. If needed, the BYPASS instruction can be issued to make the shortest possible scan chain through the device. The device can be set in the reset state by pulling the external RESET_N pin low.

The EXTEST instruction is used for sampling external pins and loading output pins with data. The data from the output latch will be driven out on the pins as soon as the EXTEST instruction is loaded into the JTAG IR-register. Therefore, the SAMPLE/PRELOAD should also be used for setting initial values to the scan ring, to avoid damaging the board when issuing the EXTEST

instruction for the first time. SAMPLE/PRELOAD can also be used for taking a snapshot of the external pins during normal operation of the part.

When using the JTAG interface for Boundary-Scan, the JTAG TCK clock is independent of the internal chip clock, which is not required to run.

NOTE: For pins connected to 5V lines care should be taken to not drive the pins to a logic one using boundary scan, as this will create a current flowing from the 3.3V driver to the 5V pullup on the line. Optionally a series resistor can be added between the line and the pin to reduce the current.

8.11.7 Flash Programming typical procedure

Flash programming is performed by operating Flash controller commands. The Flash controller is connected to the system bus matrix and is then controllable from the AHB-AP. The AHB-AP cannot write the FLASH page buffer while the core_hold_reset is asserted. The AHB-AP cannot be accessed when the device is in protected state. It is important to ensure that the CPU is halted prior to operating any flash programming operation to prevent it from corrupting the system configuration. The recommended sequence is shown below:

1. At power up, RESET_N is driven low by a debugger. The on-chip regulator holds the system in a POR state until the input supply is above the POR threshold. The system continues to be held in this static state until the internally regulated supplies have reached a safe operating.
2. PM starts, clocks are switched to the slow clock (Core Clock, System Clock, Flash Clock, and any Bus Clocks that do not have clock gate control). Internal resets are maintained due to the external reset.
 - The Debug Port (DP) and Access Ports (AP) receives a clock and leave the reset state,
3. The debugger maintains a low level on TCK and release RESET_N.
 - The SMAP asserts the core_hold_reset signal
4. The Cortex-M4 core remains in reset state, meanwhile the rest of the system is released.
5. The debugger then configures the NVIC to catch the Cortex-M4 core reset vector fetch. For more information on how to program the NVIC, refer to the ARMv7-M Architecture Reference Manual.
6. The debugger writes a one in the SMAP SCR.HCR to release the Cortex-M4 core reset to make the system bus matrix accessible from the AHB-AP.
7. The Cortex-M4 core initializes the SP, then read the exception vector and stalls
8. Programming is available through the AHB-AP
9. After operation is completed, the chip can be restarted either by asserting RESET_N or switching power off/on or clearing SCR.HCR. Make sure that the TCK pin is high when releasing RESET_N not to halt the core.

8.11.8 Chip erase typical procedure

The chip erase operation is triggered by writing a one in the CE bit in the Control Register (CR.CE). This clears first all volatile memories in the system and second the whole flash array. Note that the User page is not erased in this process. To ensure that the chip erase operation is completed, check the DONE bit in the Status Register (SR.DONE). Also note that the chip erase operation depends on clocks and power management features that can be altered by the CPU. It is important to ensure that it is stopped. The recommended sequence is shown below:

1. At power up, RESET_N is driven low by a debugger. The on-chip regulator holds the system in a POR state until the input supply is above the POR threshold. The system continues to be held in this static state until the internally regulated supplies have reached a safe operating.
 - The debug port and access ports receives a clock and leave the reset state
2. PM starts, clocks are switched to the slow clock (Core Clock, System Clock, Flash Clock, and any Bus Clocks that do not have clock gate control). Internal resets are maintained due to the external reset.
 - The debug port and access ports receives a clock and leave the reset state
3. The debugger maintains a low level on TCK and release RESET_N.
 - The SMAP asserts the core_hold_reset signal
4. The Cortex-M4 core remains in reset state, meanwhile the rest of the system is released.
5. The Chip erase operation can be performed by issuing the SMAP Chip Erase command. In this case:
 - volatile memories are cleared first
 - followed by the clearing of the flash array
 - followed by the clearing of the protected state
6. After operation is completed, the chip must be restarted by either controlling RESET_N or switching power off/on. Make sure that the TCK pin is high when releasing RESET_N not to halt the core.

8.11.9 Setting the protected state

This is done by issuing a specific flash controller command, for more information, refer to the Flash Controller chapter and to section 8.11.7Flash Programming typical procedure⁹⁶. The protected state is defined by a highly secure Flash builtin mechanism. Note that for this programming to propagate, it is required to reset the chip.

9. Electrical Characteristics

9.1 Absolute Maximum Ratings*

Table 9-1. Absolute Maximum Ratings

Operating temperature.....	-40°C to +85°C
Storage temperature.....	-60°C to +150°C
Voltage on input pins with respect to ground	-0.3V to $V_{VDD}^{(1)}+0.3V$
Total DC output current on all I/O pins VDDIO	120 mA
Total DC output current on all I/O pins VDDIN	100 mA
Total DC output current on all I/O pins VDDANA.....	50 mA
Maximum operating voltage VDDIO, VDDIN	3.6V

*NOTICE: Stresses beyond those listed under “Absolute Maximum Ratings” may cause permanent damage to the device. This is a stress rating only and functional operation of the device at these or other conditions beyond those indicated in the operational sections of this specification is not implied. Exposure to absolute maximum rating conditions for extended periods may affect device reliability.

1. V_{VDD} corresponds to either V_{VDDIN} or V_{VDDIO} , depending on the supply for the pin. Refer to [Section 3-5 on page 12](#) for details

9.2 Operating Conditions

All the electrical characteristics are applicable to the following conditions unless otherwise specified :

- operating voltage range 1,68V to 3,6V for VDDIN, VDDIO & VDDANA
- Power Scaling 0 and 2 modes
- operating temperature range: $T_A = -40^{\circ}C$ to $85^{\circ}C$ and for a junction temperature up to $T_J = 100^{\circ}C$.

Typical values are base on $T_A = 25^{\circ}c$ and $V_{VDDIN}, V_{VDDIO}, V_{VDDANA} = 3,3V$ unless otherwise specified

9.3 Supply Characteristics

Table 9-2. Supply Characteristics

Symbol	Conditions	Voltage		
		Min	Max	Unit
$V_{VDDIO},$ $V_{VDDIN},$ V_{VDDANA}	PS1 (FCPU \leq 12MHz) Linear mode	1.68	3.6	V
	PS0 & PS2 (FCPU $>$ 12MHz) Linear mode	1.8		
	Switching mode	2.0 ⁽¹⁾		

1. Below 2.3V, linear mode is more power efficient than switching mode.

Refer to [Section 6. "Power and Startup Considerations" on page 45](#) for details about Power Supply

Table 9-3. Supply Rise Rates and Order ⁽¹⁾

VDDIO, VDDIN and VDDANA must be connected together and as a consequence, rise synchronously

Symbol	Parameter	Rise Rate			
		Min	Max	Unit	Comment
V _{VDDIO}	DC supply peripheral I/Os	0.0001	2.5	V/μs	
V _{VDDIN}	DC supply peripheral I/Os and internal regulator	0.0001	2.5	V/μs	
V _{VDDANA}	Analog supply voltage	0.0001	2.5	V/μs	

1. These values are based on characterization. These values are not covered by test limits in production.

9.4 Maximum Clock Frequencies

Table 9-4. Maximum Clock Frequencies in Power Scaling Mode 0/2 and RUN Mode

Symbol	Parameter	Description	Max	Units
f_{CPU}	CPU clock frequency		48	MHz
f_{PBA}	PBA clock frequency		48	
f_{PBB}	PBB clock frequency		48	
f_{PBC}	PBC clock frequency		48	
f_{PBD}	PBD clock frequency		48	
f_{GCLK0}	GCLK0 clock frequency	DPLLIF main reference, GCLK0 pin	50	
f_{GCLK1}	GCLK1 clock frequency	DPLLIF dithering and SSG reference, GCLK1 pin	50	
f_{GCLK2}	GCLK2 clock frequency	AST, GCLK2 pin	20	
f_{GCLK3}	GCLK3 clock frequency	CATB, GCLK3 pin	50	
f_{GCLK4}	GCLK4 clock frequency	FLO and AESA	50	
f_{GCLK5}	GCLK5 clock frequency	GLOC, TC0 and RC32KIFB_REF	80	
f_{GCLK6}	GCLK6 clock frequency	ABDACB and IISC	50	
f_{GCLK7}	GCLK7 clock frequency	USBC	50	
f_{GCLK8}	GCLK8 clock frequency	TC1 and PEVC[0]	50	
f_{GCLK9}	GCLK9 clock frequency	PLL0 and PEVC[1]	50	
f_{GCLK10}	GCLK10 clock frequency	ADCIFE	50	
f_{GCLK11}	GCLK11 clock frequency	Master generic clock. Can be used as source for other generic clocks	150	
f_{OSC0}	OSC0 output frequency	Oscillator 0 in crystal mode	30	
		Oscillator 0 in digital clock mode	50	
f_{PLL}	PLL output frequency	Phase Locked Loop	240	
f_{DFLL}	DFLL output frequency	Digital Frequency Locked Loop	220	
f_{RC80M}	RC80M output frequency	Internal 80MHz RC Oscillator	80	

Table 9-5. Maximum Clock Frequencies in Power Scaling Mode 1 and RUN Mode

Symbol	Parameter	Description	Max	Units
f_{CPU}	CPU clock frequency		12	MHz
f_{PBA}	PBA clock frequency		12	
f_{PBB}	PBB clock frequency		12	
f_{PBC}	PBC clock frequency		12	
f_{PBD}	PBD clock frequency		12	
f_{GCLK0}	GCLK0 clock frequency	DPLLIF main reference, GCLK0 pin	16.6	
f_{GCLK1}	GCLK1 clock frequency	DPLLIF dithering and SSGreference, GCLK1 pin	16.6	
f_{GCLK2}	GCLK2 clock frequency	AST, GCLK2 pin	6.6	
f_{GCLK3}	GCLK3 clock frequency	CATB, GCLK3 pin	17.3	
f_{GCLK4}	GCLK4 clock frequency	FLO and AESA	16.6	
f_{GCLK5}	GCLK5 clock frequency	GLOC, TC0 and RC32KIFB_REF	26.6	
f_{GCLK6}	GCLK6 clock frequency	ABDACB and IISC	16.6	
f_{GCLK7}	GCLK7 clock frequency	USBC	16.6	
f_{GCLK8}	GCLK8 clock frequency	TC1 and PEVC[0]	16.6	
f_{GCLK9}	GCLK9 clock frequency	PLL0 and PEVC[1]	16.6	
f_{GCLK10}	GCLK10 clock frequency	ADCIFE	16.6	
f_{GCLK11}	GCLK11 clock frequency	Master generic clock. Can be used as source for other generic clocks	51.2	
f_{OSC0}	OSC0 output frequency	Oscillator 0 in crystal mode	16	
		Oscillator 0 in digital clock mode	16	
f_{PLL}	PLL output frequency	Phase Locked Loop	N/A	
f_{DFLL}	DFLL output frequency	Digital Frequency Locked Loop	N/A	
f_{RC80M}	RC80M output frequency	Internal 80MHz RC Oscillator	N/A	

9.5 Power Consumption

9.5.1 Power Scaling 0 and 2

The values in [Table 9-6](#) are measured values of power consumption under the following conditions, except where noted:

- Operating conditions for power scaling mode 0 and 2
 - $V_{DDIN} = 3.3V$
 - Power Scaling mode 0 is used for CPU frequencies under 36MHz
 - Power Scaling mode 2 is used for CPU frequencies above 36MHz
- Wake up time from low power modes is measured from the edge of the wakeup signal to the first instruction fetched in flash.
- Oscillators
 - OSC0 (crystal oscillator) stopped
 - OSC32K (32kHz crystal oscillator) running with external 32kHz crystal
 - DFLL using OSC32K as reference and running at 48MHz
- Clocks
 - DFLL used as main clock source
 - CPU, AHB clocks undivided
 - APBC and APBD clocks divided by 4
 - APBA and APBB bridges off
 - The following peripheral clocks running
 - PM, SCIF, AST, FLASHCALW, APBC and APBD bridges
 - All other peripheral clocks stopped
- I/Os are inactive with internal pull-up
- CPU is running on flash with 1 wait state
- Low power cache enabled
- BOD18 and BOD33 disabled

Table 9-6. ATSAM4L4/2 Current consumption and Wakeup time for power scaling mode 0 and 2

Mode	Conditions	T _A	Typical Wakeup Time	Typ	Max ⁽¹⁾	Unit
RUN	CPU running a Fibonacci algorithm Linear mode	25°C	N/A	296	326	μA/MHz
		85°C		300	332	
	CPU running a CoreMark algorithm Linear mode	25°C	N/A	320	377	
		85°C		326	380	
	CPU running a Fibonacci algorithm Switching mode	25°C	N/A	177	198	
		85°C		179	200	
CPU running a CoreMark algorithm Switching mode	25°C	N/A	186	232		
	85°C		195	239		

Table 9-6. ATSAM4L4/2 Current consumption and Wakeup time for power scaling mode 0 and 2

Mode	Conditions	T _A	Typical Wakeup Time	Typ	Max ⁽¹⁾	Unit
SLEEP0	Switching mode	25°C	9 * Main clock cycles	3817	4033	μA
		85°C		3934	4174	
SLEEP1	Switching mode	25°C	9 * Main clock cycles + 500ns	2341	2477	
		85°C		2437	2585	
SLEEP2	Switching mode	25°C	9 * Main clock cycles + 500ns	1758	1862	
		85°C		1847	1971	
SLEEP3	Linear mode	25°C	1.5μs	51	60	
WAIT	OSC32K and AST running Fast wake-up enable			5.9	8.7	
	OSC32K and AST stopped Fast wake-up enable			4.7	7.6	
RETENTION	OSC32K running AST running at 1kHz			3.1	5.1	
	AST and OSC32K stopped			2.2	4.2	
BACKUP	OSC32K running AST running at 1kHz			1.5	3.1	
	AST and OSC32K stopped			0.9	1.7	

1. These values are based on characterization. These values are not covered by test limits in production.

Table 9-7. ATSAM4L8 Current consumption and Wakeup time for power scaling mode 0 and 2

Mode	Conditions	T _A	Typical Wakeup Time	Typ	Max ⁽¹⁾	Unit
RUN	CPU running a Fibonacci algorithm Linear mode	25°C	N/A	319	343	μA/MHz
		85°C		326	350	
	CPU running a CoreMark algorithm Linear mode	25°C	N/A	343	387	
		85°C		351	416	
	CPU running a Fibonacci algorithm Switching mode	25°C	N/A	181	198	
		85°C		186	203	
	CPU running a CoreMark algorithm Switching mode	25°C	N/A	192	232	
		85°C		202	239	

Table 9-7. ATSAM4L8 Current consumption and Wakeup time for power scaling mode 0 and 2

Mode	Conditions	T _A	Typical Wakeup Time	Typ	Max ⁽¹⁾	Unit
SLEEP0	Switching mode	25°C	9 * Main clock cycles	3817	4033	μA
		85°C		4050	4507	
SLEEP1	Switching mode	25°C	9 * Main clock cycles + 500ns	2341	2477	
		85°C		2525	2832	
SLEEP2	Switching mode	25°C	9 * Main clock cycles + 500ns	1758	1862	
		85°C		1925	1971	
SLEEP3	Linear mode	25°C	1.5μs	51	60	
WAIT	OSC32K and AST running Fast wake-up enable			6.7		
	OSC32K and AST stopped Fast wake-up enable			5.5		
RETENTION	OSC32K running AST running at 1kHz			3.9		
	AST and OSC32K stopped			3.0		
BACKUP	OSC32K running AST running at 1kHz			1.5	3.1	
	AST and OSC32K stopped			0.9	1.7	

1. These values are based on characterization. These values are not covered by test limits in production.

9.5.2 Power Scaling 1

The values in [Table 34-7](#) are measured values of power consumption under the following conditions, except where noted:

- Operating conditions for power scaling mode 1
 - V_{DDIN} = 3.3V
- Wake up time from low power modes is measured from the edge of the wakeup signal to the first instruction fetched in flash.
- Oscillators
 - OSC0 (crystal oscillator) and OSC32K (32kHz crystal oscillator) stopped
 - RCFAST Running at 12MHz
- Clocks
 - RCFAST used as main clock source
 - CPU, AHB clocks undivided
 - APBC and APBD clocks divided by 4
 - APBA and APBB bridges off
 - The following peripheral clocks running
 - PM, SCIF, AST, FLASHCALW, APBC and APBD bridges

- All other peripheral clocks stopped
- I/Os are inactive with internal pull-up
- CPU is running on flash with 1 wait state
- Low power cache enabled
- BOD18 and BOD33 disabled

Table 9-8. ATSAM4L4/2 Current consumption and Wakeup time for power scaling mode 1

Mode	Conditions	T _A	Typical Wakeup Time	Typ	Max ⁽¹⁾	Unit
RUN	CPU running a Fibonacci algorithm Linear mode	25°C	N/A	205	224	μA/MHz
		85°C		212	231	
	CPU running a CoreMark algorithm Linear mode	25°C	N/A	213	244	
		85°C		230	270	
	CPU running a Fibonacci algorithm Switching mode	25°C	N/A	95	112	
		85°C		100	119	
	CPU running a CoreMark algorithm Switching mode	25°C	N/A	100	128	
		85°C		107	138	
SLEEP0	Switching mode	25°C	9 * Main clock cycles	527	627	μA
		85°C		579	739	
SLEEP1	Switching mode	25°C	9 * Main clock cycles + 500ns	369	445	
		85°C		404	564	
SLEEP2	Switching mode	25°C	9 * Main clock cycles + 500ns	305	381	
		85°C		334	442	
SLEEP3	Linear mode	25°C	1.5μs	46	55	
WAIT	OSC32K and AST running Fast wake-up enable			4.7	7.5	
	OSC32K and AST stopped Fast wake-up enable			3.5	6.3	
RETENTION	OSC32K running AST running at 1 kHz			2.6	4.8	
	AST and OSC32K stopped			1.5	4	
BACKUP	OSC32K running AST running at 1 kHz			1.5	3.1	
	AST and OSC32K stopped			0.9	1.7	

1. These values are based on characterization. These values are not covered by test limits in production.

Table 9-9. ATSAM4L8 Current consumption and Wakeup time for power scaling mode 1

Mode	Conditions	T _A	Typical Wakeup Time	Typ	Max ⁽¹⁾	Unit
RUN	CPU running a Fibonacci algorithm Linear mode	25°C	N/A	222	240	μA/MHz
		85°C		233	276	
	CPU running a CoreMark algorithm Linear mode	25°C	N/A	233	276	
		85°C		230	270	
	CPU running a Fibonacci algorithm Switching mode	25°C	N/A	100	112	
		85°C		100	119	
CPU running a CoreMark algorithm Switching mode	25°C	N/A	104	128		
	85°C		107	138		
SLEEP0	Switching mode	25°C	9 * Main clock cycles	527	627	μA
		85°C		579	739	
SLEEP1	Switching mode	25°C	9 * Main clock cycles + 500ns	369	445	
		85°C		404	564	
SLEEP2	Switching mode	25°C	9 * Main clock cycles + 500ns	305	381	
		85°C		334	442	
SLEEP3	Linear mode	25°C		46	55	
WAIT	OSC32K and AST running Fast wake-up enable		1.5μs	5.5		
	OSC32K and AST stopped Fast wake-up enable			4.3		
RETENTION	OSC32K running AST running at 1 kHz		1.5μs	3.4		
	AST and OSC32K stopped			2.3		
BACKUP	OSC32K running AST running at 1 kHz			1.5	3.1	
	AST and OSC32K stopped			0.9	1.7	

1. These values are based on characterization. These values are not covered by test limits in production.

Table 9-10. Typical Power Consumption running CoreMark on CPU clock sources ⁽¹⁾

Clock Source	Conditions	Regulator	Frequency (MHz)	Typ	Unit
--------------	------------	-----------	-----------------	-----	------

Table 9-10. Typical Power Consumption running CoreMark on CPU clock sources ⁽¹⁾

RCSYS (MCSEL = 0)	Power scaling mode 1	Switching Mode	0.115	978	μA/MHz
OSC0 (MCSEL = 1)	Power scaling mode 1		0.5	354	
	Power scaling mode 0		12	114	
			12	228	
			30	219	
OSC0 (MCSEL = 1) External Clock (MODE=0)	Power scaling mode 1		0.6	292	
	Power scaling mode 0		12	111	
	Power scaling mode 2		12	193	
PLL (MCSEL = 2)	Power scaling mode 2 Input Freq = 4MHz from OSC0		50	194	
			40	188	
DFLL (MCSEL = 3)	Power scaling mode 0 Input Freq = 32kHz from OSC32K		50	185	
			20	214	
RC1M (MCSEL = 4)	Power scaling mode 2 Input Freq = 32kHz from OSC32K		50	195	
			1	267	
RCFAST (MCSEL = 5)	Power scaling mode 1 RCFAST frequency is configurable from 4 to 12MHz	4	153		
		12	114		
RC80M (MCSEL = 6)	Power scaling mode 1 $f_{CPU} = RC80M / 2 = 40MHz$	40	211		

1. These values are based on characterization. These values are not covered by test limits in production.

Figure 9-1. Typical Power Consumption running Coremark (from above table)

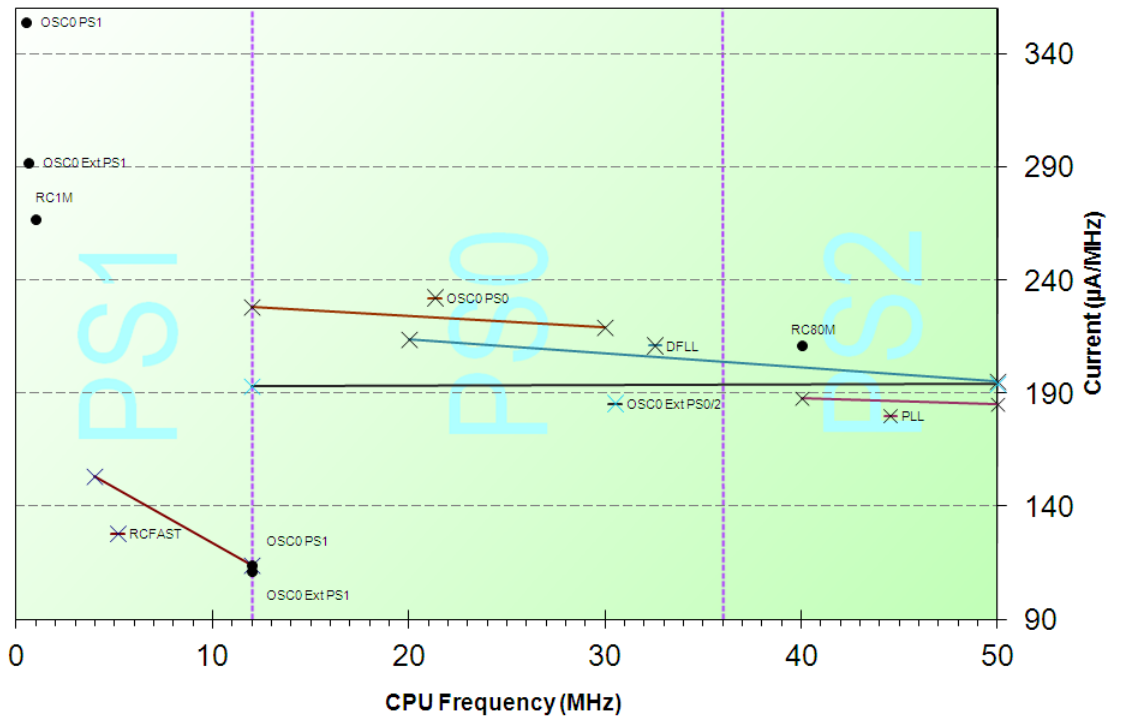

Note: For variable frequency oscillators, linear interpolation between high and low settings

Figure 9-2. Measurement Schematic, Switching Mode

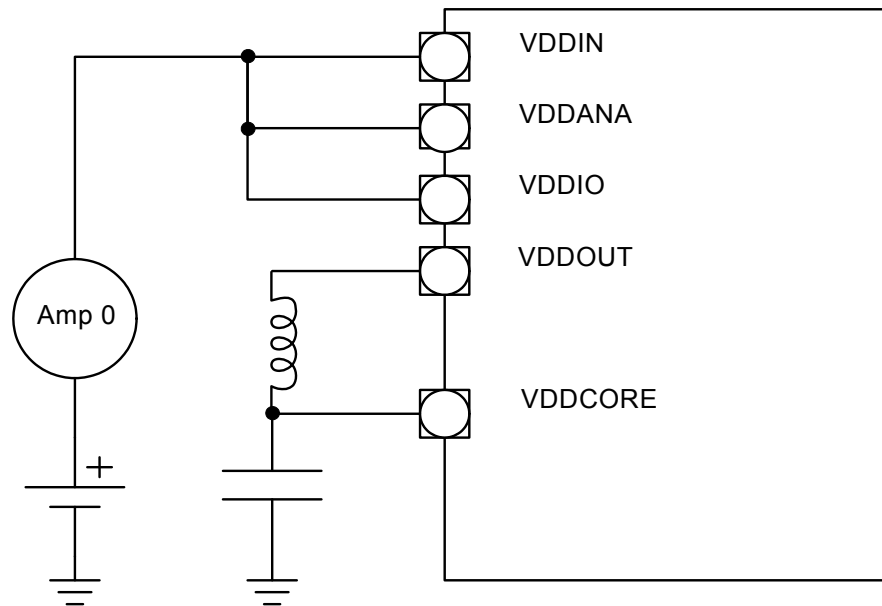

9.5.3 Peripheral Power Consumption in Power Scaling mode 0 and 2

The values in [Table 9-11](#) are measured values of power consumption under the following conditions:

- Operating conditions, internal core supply ([Figure 9-2](#))
 - $V_{VDDIN} = 3.3V$
 - $V_{VDDCORE}$ supplied by the internal regulator in switching mode
- $T_A = 25^{\circ}C$
- Oscillators
 - OSC0 (crystal oscillator) stopped
 - OSC32K (32KHz crystal oscillator) running with external 32KHz crystal
 - DFLL running at 48MHz with OSC32K as reference clock
- Clocks
 - DFLL used as main clock source
 - CPU, AHB, and PB clocks undivided
- I/Os are inactive with internal pull-up
- Flash enabled in high speed mode
- CPU in SLEEP0 mode
- BOD18 and BOD33 disabled

Consumption active is the added current consumption when the module clock is turned on.

Table 9-11. Typical Current Consumption by Peripheral in Power Scaling Mode 0 and 2 ⁽¹⁾

Peripheral	Typ Consumption Active	Unit
IISC	1.0	μA/MHz
SPI	1.9	
TC	6.3	
TWIM	1.5	
TWIS	1.2	
USART	8.5	
ADCIFE ⁽²⁾	3.1	
DACC	1.3	
ACIFC ⁽²⁾	3.1	
GLOC	0.4	
ABDACB	0.7	
TRNG	0.9	
PARC	0.7	
CATB	3.0	
LCDCA	4.4	
PDCA	1.0	
CRCCU	0.3	
USBC	1.5	
PEVC	5.6	
CHIPID	0.1	
SCIF	6.4	
FREQM	0.5	
GPIO	7.1	
BPM	0.9	
BSCIF	4.6	
AST	1.5	
WDT	1.4	
EIC	0.6	
PICOUART	0.3	

1. These numbers are valid for the measured condition only and must not be extrapolated to other frequencies
2. Includes the current consumption on VDDANA and ADVREFFP.

9.5.4 .Peripheral Power Consumption in Power Scaling mode 1

The values in [Table 9-13](#) are measured values of power consumption under the following conditions:

- Operating conditions, internal core supply (Figure 9-2)
 - $V_{VDDIN} = 3.3V$
 - $V_{VDDCORE} = 1.2 V$, supplied by the internal regulator in switching mode
- $T_A = 25^{\circ}C$
- Oscillators
 - OSC0 (crystal oscillator) stopped
 - OSC32K (32KHz crystal oscillator) running with external 32KHz crystal
 - RCFAST running @ 12MHz
- Clocks
 - RCFAST used as main clock source
 - CPU, AHB, and PB clocks undivided
- I/Os are inactive with internal pull-up
- Flash enabled in normal mode
- CPU in SLEEP0 mode
- BOD18 and BOD33 disabled

Consumption active is the added current consumption when the module clock is turned on

Table 9-12. Typical Current Consumption by Peripheral in Power Scaling Mode 1 ⁽¹⁾

Peripheral	Typ Consumption Active	Unit
IISC	0.5	μA/MHz
SPI	1.1	
TC	3.1	
TWIM	0.8	
TWIS	0.7	
USART	4.4	
ADCIFE ⁽²⁾	1.6	
DACC	0.6	
ACIFC ⁽²⁾	1.6	
GLOC	0.1	
ABDACB	0.3	
TRNG	0.3	
PARC	0.3	
CATB	1.5	
LCDCA	2.2	
PDCA	0.4	
CRCCU	0.3	
USBC	0.9	
PEVC	2.8	
CHIPID	0.1	
SCIF	3.1	
FREQM	0.2	
GPIO	3.4	
BPM	0.4	
BSCIF	2.3	
AST	0.8	
WDT	0.8	
EIC	0.3	
PICOUART	0.2	

1. These numbers are valid for the measured condition only and must not be extrapolated to other frequencies
2. Includes the current consumption on VDDANA and ADVREFFP.

9.6 I/O Pin Characteristics

9.6.1 Normal I/O Pin

Table 9-13. Normal I/O Pin Characteristics ⁽¹⁾

Symbol	Parameter	Conditions	Min	Typ	Max	Units
R _{PULLUP}	Pull-up resistance ⁽²⁾			40		kΩ
R _{PULLDOWN}	Pull-down resistance ⁽²⁾			40		kΩ
V _{IL}	Input low-level voltage		-0.3		0.2 * V _{VDD}	V
V _{IH}	Input high-level voltage		0.8 * V _{VDD}		V _{VDD} + 0.3	
V _{OL}	Output low-level voltage				0.4	
V _{OH}	Output high-level voltage		V _{VDD} - 0.4			
I _{OL}	Output low-level current ⁽³⁾	ODCR0=0	1.68V < V _{VDD} < 2.7V		0.8	mA
			2.7V < V _{VDD} < 3.6V		1.6	
		ODCR0=1	1.68V < V _{VDD} < 2.7V		1.6	mA
			2.7V < V _{VDD} < 3.6V		3.2	
I _{OH}	Output high-level current ⁽³⁾	ODCR0=0	1.68V < V _{VDD} < 2.7V		0.8	mA
			2.7V < V _{VDD} < 3.6V		1.6	
		ODCR0=1	1.68V < V _{VDD} < 2.7V		1.6	mA
			2.7V < V _{VDD} < 3.6V		3.2	
t _{RISE}	Rise time ⁽²⁾	OSRR0=0	ODCR0=0		35	ns
			1.68V < V _{VDD} < 2.7V, load = 25pF		45	
		OSRR0=1	ODCR0=0		19	ns
			2.7V < V _{VDD} < 3.6V, load = 25pF		23	
t _{FALL}	Fall time ⁽²⁾	OSRR0=0	ODCR0=0		36	ns
			1.68V < V _{VDD} < 2.7V, load = 25pF		47	
		OSRR0=1	ODCR0=0		20	ns
			2.7V < V _{VDD} < 3.6V, load = 25pF		24	
F _{PINMAX}	Output frequency ⁽²⁾	OSRR0=0	ODCR0=0, V _{VDD} > 2.7V		17	MHz
			load = 25pF		15	MHz
		OSRR0=1	ODCR0=0, V _{VDD} > 2.7V		27	MHz
			load = 25pF		23	MHz
I _{LEAK}	Input leakage current ⁽³⁾	Pull-up resistors disabled		0.01	1	μA
C _{IN}	Input capacitance ⁽²⁾			5		pF

- V_{VDD} corresponds to either V_{VDDIN} or V_{VDDIO}, depending on the supply for the pin. Refer to [Section 3-5 on page 12](#) for details
- These values are based on simulation. These values are not covered by test limits in production or characterization

3. These values are based on characterization. These values are not covered by test limits in production

9.6.2 High-drive I/O Pin : PA02, PC04, PC05, PC06

Table 9-14. High-drive I/O Pin Characteristics ⁽¹⁾

Symbol	Parameter	Conditions	Min	Typ	Max	Units
R _{PULLUP}	Pull-up resistance ⁽²⁾			40		kΩ
R _{PULLDOWN}	Pull-down resistance ⁽²⁾			40		kΩ
V _{IL}	Input low-level voltage		-0.3		0.2 * V _{VDD}	V
V _{IH}	Input high-level voltage		0.8 * V _{VDD}		V _{VDD} + 0.3	
V _{OL}	Output low-level voltage				0.4	
V _{OH}	Output high-level voltage		V _{VDD} - 0.4			
I _{OL}	Output low-level current ⁽³⁾	ODCR0=0	1.68V < V _{VDD} < 2.7V		1.8	mA
			2.7V < V _{VDD} < 3.6V		3.2	
		ODCR0=1	1.68V < V _{VDD} < 2.7V		3.2	mA
			2.7V < V _{VDD} < 3.6V		6	
I _{OH}	Output high-level current ⁽³⁾	ODCR0=0	1.68V < V _{VDD} < 2.7V		1.6	mA
			2.7V < V _{VDD} < 3.6V		3.2	
		ODCR0=1	1.68V < V _{VDD} < 2.7V		3.2	mA
			2.7V < V _{VDD} < 3.6V		6	
t _{RISE}	Rise time ⁽²⁾	OSRR0=0	ODCR0=0		20	ns
			1.68V < V _{VDD} < 2.7V, Cload = 25pF		40	
		OSRR0=1	ODCR0=0		11	ns
			2.7V < V _{VDD} < 3.6V, Cload = 25pF		18	
t _{FALL}	Fall time ⁽²⁾	OSRR0=0	ODCR0=0		20	ns
			1.68V < V _{VDD} < 2.7V, Cload = 25pF		40	
		OSRR0=1	ODCR0=0		11	ns
			2.7V < V _{VDD} < 3.6V, Cload = 25pF		18	
F _{PINMAX}	Output frequency ⁽²⁾	OSRR0=0	ODCR0=0, V _{VDD} > 2.7V		22	MHz
			load = 25pF		17	
		OSRR0=1	ODCR0=0, V _{VDD} > 2.7V		35	MHz
			load = 25pF		26	
I _{LEAK}	Input leakage current ⁽³⁾	Pull-up resistors disabled		0.01	2	μA
C _{IN}	Input capacitance ⁽²⁾			10		pF

1. V_{VDD} corresponds to either V_{VDDIN} or V_{VDDIO}; depending on the supply for the pin. Refer to [Section 3-5 on page 12](#) for details
2. These values are based on simulation. These values are not covered by test limits in production or characterization
3. These values are based on characterization. These values are not covered by test limits in production

9.6.3 USB I/O Pin : PA25, PA26

Table 9-15. USB I/O Pin Characteristics in GPIO configuration ⁽¹⁾

Symbol	Parameter	Conditions		Min	Typ	Max	Units
R _{PULLUP}	Pull-up resistance ⁽²⁾				40		kΩ
R _{PULLDOWN}	Pull-down resistance ⁽²⁾				40		kΩ
V _{IL}	Input low-level voltage			-0.3		0.2 * V _{VDD}	V
V _{IH}	Input high-level voltage			0.8 * V _{VDD}		V _{VDD} + 0.3	
V _{OL}	Output low-level voltage					0.4	
V _{OH}	Output high-level voltage			V _{VDD} - 0.4			
I _{OL}	Output low-level current ⁽³⁾	ODCR0=0	1.68V < V _{VDD} < 2.7V		20		mA
			2.7V < V _{VDD} < 3.6V		30		
I _{OH}	Output high-level current ⁽³⁾	ODCR0=0	1.68V < V _{VDD} < 2.7V		20		mA
			2.7V < V _{VDD} < 3.6V		30		
F _{PINMAX}	Maximum frequency ⁽²⁾	ODCR0=0 OSRR0=0	load = 25pF			20	MHz
I _{LEAK}	Input leakage current ⁽³⁾	Pull-up resistors disabled			0.01	1	μA
C _{IN}	Input capacitance ⁽²⁾				5		pF

1. V_{VDD} corresponds to either V_{VDDIN} or V_{VDDIO}, depending on the supply for the pin. Refer to [Section 3-5 on page 12](#) for details
2. These values are based on simulation. These values are not covered by test limits in production or characterization
3. These values are based on characterization. These values are not covered by test limits in production

9.6.4 TWI Pin : PA21, PA22, PA23, PA24, PB14, PB15

Table 9-16. TWI Pin Characteristics in TWI configuration ⁽¹⁾

Symbol	Parameter	Conditions		Min	Typ	Max	Units
R _{PULLUP}	Pull-up resistance ⁽²⁾				40		kΩ
R _{PULLDOWN}	Pull-down resistance ⁽²⁾				40		kΩ
V _{IL}	Input low-level voltage			-0.3		0.3 * V _{VDD}	V
V _{IH}	Input high-level voltage			0.7 * V _{VDD}		V _{VDD} + 0.3	V
V _{OL}	Output low-level voltage					0.4	V
I _{OL}	Output low-level current ⁽³⁾	DRIVEL=0				0.5	mA
		DRIVEL=1				1.0	
		DRIVEL=2				1.6	
		DRIVEL=3				3.1	
		DRIVEL=4				6.2	
		DRIVEL=5				9.3	
		DRIVEL=6				15.5	
		DRIVEL=7				21.8	

Table 9-16. TWI Pin Characteristics in TWI configuration ⁽¹⁾

Symbol	Parameter	Conditions	Min	Typ	Max	Units
I _{CS}	Current Source ⁽³⁾	DRIVEH=0		0.5		mA
		DRIVEH=1		1		
		DRIVEH=2		1.5		
		DRIVEH=3		3		
f _{MAX}	Max frequency ⁽²⁾	HsMode with Current source; DRIVEx=3, SLEW=0 Cbus = 400pF, V _{VDD} = 1.68V	3.5	6.4		MHz
t _{RISE}	Rise time ⁽²⁾	HsMode Mode, DRIVEx=3, SLEW=0 Cbus = 400pF, Rp = 440Ohm, V _{VDD} = 1.68V		28	38	ns
t _{FALL}	Fall time ⁽²⁾	Standard Mode, DRIVEx=3, SLEW=0 Cbus = 400pF, Rp = 440Ohm, V _{VDD} = 1.68V		50	95	ns
		HsMode Mode, DRIVEx=3, SLEW=0 Cbus = 400pF, Rp = 440Ohm, V _{VDD} = 1.68V		50	95	

1. V_{VDD} corresponds to either V_{VDDIN} or V_{VDDIO}, depending on the supply for the pin. Refer to [Section 3-5 on page 12](#) for details
2. These values are based on simulation. These values are not covered by test limits in production or characterization
3. These values are based on characterization. These values are not covered by test limits in production

Table 9-17. TWI Pin Characteristics in GPIO configuration ⁽¹⁾

Symbol	Parameter	Conditions	Min	Typ	Max	Units
R _{PULLUP}	Pull-up resistance ⁽²⁾			40		kΩ
R _{PULLDOWN}	Pull-up resistance ⁽²⁾			40		kΩ
V _{IL}	Input low-level voltage		-0.3		0.2 * V _{VDD}	V
V _{IH}	Input high-level voltage		0.8 * V _{VDD}		V _{VDD} + 0.3	V
V _{OL}	Output low-level voltage				0.4	V
V _{OH}	Output high-level voltage		V _{VDD} - 0.4			
I _{OL}	Output low-level current ⁽³⁾	ODCR0=0	1.68V < V _{VDD} < 2.7V		1.8	mA
			2.7V < V _{VDD} < 3.6V		3.5	
		ODCR0=1	1.68V < V _{VDD} < 2.7V		3.6	
			2.7V < V _{VDD} < 3.6V		6.8	
I _{OH}	Output high-level current ⁽³⁾	ODCR0=0	1.68V < V _{VDD} < 2.7V		1.8	mA
			2.7V < V _{VDD} < 3.6V		3.5	
		ODCR0=1	1.68V < V _{VDD} < 2.7V		3.6	
			2.7V < V _{VDD} < 3.6V		6.8	

Table 9-17. TWI Pin Characteristics in GPIO configuration ⁽¹⁾

Symbol	Parameter	Conditions	Min	Typ	Max	Units
t _{RISE}	Rise time ⁽²⁾	OSRR0=0	ODCR0=0		18	ns
		OSRR0=1	1.68V < V _{VDD} < 2.7V, Cl _{oad} = 25pF		110	
		OSRR0=0	ODCR0=0		10	ns
		OSRR0=1	2.7V < V _{VDD} < 3.6V, Cl _{oad} = 25pF		50	
t _{FALL}	Fall time ⁽²⁾	OSRR0=0	ODCR0=0		19	ns
		OSRR0=1	1.68V < V _{VDD} < 2.7V, Cl _{oad} = 25pF		140	
		OSRR0=0	ODCR0=0		12	ns
		OSRR0=1	2.7V < V _{VDD} < 3.6V, Cl _{oad} = 25pF		63	

1. V_{VDD} corresponds to either V_{VDDIN} or V_{VDDIO}, depending on the supply for the pin. Refer to [Section 3-5 on page 12](#) for details
2. These values are based on simulation. These values are not covered by test limits in production or characterization
3. These values are based on characterization. These values are not covered by test limits in production

Table 9-18. Common TWI Pin Characteristics

Symbol	Parameter	Conditions	Min	Typ	Max	Units
I _{LEAK}	Input leakage current ⁽¹⁾	Pull-up resistors disabled		0.01	1	μA
C _{IN}	Input capacitance ⁽²⁾			5		pF

1. These values are based on simulation. These values are not covered by test limits in production or characterization

9.6.5 High Drive TWI Pin : PB00, PB01

Table 9-19. High Drive TWI Pin Characteristics in TWI configuration ⁽¹⁾

Symbol	Parameter	Conditions	Min	Typ	Max	Units
R _{PULLUP}	Pull-up resistance ⁽²⁾	PB00, PB01		40		kΩ
R _{PULLDOWN}	Pull-down resistance ⁽²⁾			40		kΩ
V _{IL}	Input low-level voltage		-0.3		0.3 * V _{VDD}	V
V _{IH}	Input high-level voltage		0.7 * V _{VDD}		V _{VDD} + 0.3	
V _{OL}	Output low-level voltage				0.4	
V _{OH}	Output high-level voltage		V _{VDD} - 0.4			
I _{OL}	Output low-level current ⁽³⁾	DRIVEL=0			0.5	mA
		DRIVEL=1			1.0	
		DRIVEL=2			1.6	
		DRIVEL=3			3.1	
		DRIVEL=4			6.2	
		DRIVEL=5			9.3	
		DRIVEL=6			15.5	
		DRIVEL=7			21.8	
I _{CS}	Current Source ⁽²⁾	DRIVEH=0		0.5		mA
		DRIVEH=1		1		
		DRIVEH=2		1.5		
		DRIVEH=3		3		
f _{MAX}	Max frequency ⁽²⁾	HsMode with Current source; DRIVEx=3, SLEW=0 Cbus = 400pF, V _{VDD} = 1.68V	3.5	6.4		MHz
t _{RISE}	Rise time ⁽²⁾	HsMode Mode, DRIVEx=3, SLEW=0 Cbus = 400pF, Rp = 440Ohm, V _{VDD} = 1.68V		28	38	ns
t _{FALL}	Fall time ⁽²⁾	Standard Mode, DRIVEx=3, SLEW=0 Cbus = 400pF, Rp = 440Ohm, V _{VDD} = 1.68V		50	95	ns
		HsMode Mode, DRIVEx=3, SLEW=0 Cbus = 400pF, Rp = 440Ohm, V _{VDD} = 1.68V		50	95	

1. V_{VDD} corresponds to either V_{VDDIN} or V_{VDDIO}, depending on the supply for the pin. Refer to [Section 3-5 on page 12](#) for details
2. These values are based on simulation. These values are not covered by test limits in production or characterization
3. These values are based on characterization. These values are not covered by test limits in production

Table 9-20. High Drive TWI Pin Characteristics in GPIO configuration ⁽¹⁾

Symbol	Parameter	Conditions	Min	Typ	Max	Units
R _{PULLUP}	Pull-up resistance ⁽²⁾			40		kΩ
R _{PULLDOWN}	Pull-up resistance ⁽²⁾			40		kΩ
V _{IL}	Input low-level voltage		-0.3		0.2 * V _{VDD}	V
V _{IH}	Input high-level voltage		0.8 * V _{VDD}		V _{VDD} + 0.3	
V _{OL}	Output low-level voltage				0.4	
V _{OH}	Output high-level voltage		V _{VDD} - 0.4			
I _{OL}	Output low-level current ⁽³⁾	ODCR0=0	1.68V < V _{VDD} < 2.7V		3.4	mA
			2.7V < V _{VDD} < 3.6V		6	
		ODCR0=1	1.68V < V _{VDD} < 2.7V		5.2	mA
			2.7V < V _{VDD} < 3.6V		8	
I _{OH}	Output high-level current ⁽³⁾	ODCR0=0	1.68V < V _{VDD} < 2.7V		3.4	mA
			2.7V < V _{VDD} < 3.6V		6	
		ODCR0=1	1.68V < V _{VDD} < 2.7V		5.2	mA
			2.7V < V _{VDD} < 3.6V		8	
t _{RISE}	Rise time ⁽²⁾	OSRR0=0	ODCR0=0		18	ns
			1.68V < V _{VDD} < 2.7V, Cl _{oad} = 25pF		110	
		OSRR0=1	ODCR0=0		10	ns
			2.7V < V _{VDD} < 3.6V, Cl _{oad} = 25pF		50	
t _{FALL}	Fall time ⁽²⁾	OSRR0=0	ODCR0=0		19	ns
			1.68V < V _{VDD} < 2.7V, Cl _{oad} = 25pF		140	
		OSRR0=1	ODCR0=0		12	ns
			2.7V < V _{VDD} < 3.6V, Cl _{oad} = 25pF		63	

1. V_{VDD} corresponds to either V_{VDDIN} or V_{VDDIO}, depending on the supply for the pin. Refer to [Section 3-5 on page 12](#) for details
2. These values are based on simulation. These values are not covered by test limits in production or characterization
3. These values are based on characterization. These values are not covered by test limits in production

Table 9-21. Common High Drive TWI Pin Characteristics

Symbol	Parameter	Conditions	Min	Typ	Max	Units
I _{LEAK}	Input leakage current ⁽¹⁾	Pull-up resistors disabled		0.01	2	μA
C _{IN}	Input capacitance ⁽¹⁾			10		pF

1. These values are based on simulation. These values are not covered by test limits in production or characterization

9.7 Oscillator Characteristics

9.7.1 Oscillator 0 (OSC0) Characteristics

9.7.1.1 Digital Clock Characteristics

The following table describes the characteristics for the oscillator when a digital clock is applied on XIN.

Table 9-22. Digital Clock Characteristics

Symbol	Parameter	Conditions	Min	Typ	Max	Units
f_{CPXIN}	XIN clock frequency ⁽¹⁾				50	MHz
t_{CPXIN}	XIN clock duty cycle ⁽¹⁾		40		60	%
$t_{STARTUP}$	Startup time			N/A		cycles

1. These values are based on simulation. These values are not covered by test limits in production or characterization.

9.7.1.2 Crystal Oscillator Characteristics

The following table describes the characteristics for the oscillator when a crystal is connected between XIN and XOUT as shown in [Figure 9-3](#). The user must choose a crystal oscillator where the crystal load capacitance C_L is within the range given in the table. The exact value of C_L can be found in the crystal datasheet. The capacitance of the external capacitors (C_{LEXT}) can then be computed as follows:

$$C_{LEXT} = 2(C_L - C_{STRAY} - C_{SHUNT})$$

where C_{STRAY} is the capacitance of the pins and PCB, C_{SHUNT} is the shunt capacitance of the crystal.

Table 9-23. Crystal Oscillator Characteristics

Symbol	Parameter	Conditions	Min	Typ	Max	Unit
f_{OUT}	Crystal oscillator frequency ⁽¹⁾		0.6		30	MHz
ESR	Crystal Equivalent Series Resistance ⁽²⁾	f = 0.455MHz, $C_{LEXT} = 100\text{pF}$ SCIF.OSCCTRL.GAIN = 0			17000	Ω
		f = 2MHz, $C_{LEXT} = 20\text{pF}$ SCIF.OSCCTRL.GAIN = 0			2000	
		f = 4MHz, $C_{LEXT} = 20\text{pF}$ SCIF.OSCCTRL.GAIN = 1			1500	
		f = 8MHz, $C_{LEXT} = 20\text{pF}$ SCIF.OSCCTRL.GAIN = 2			300	
		f = 16MHz, $C_{LEXT} = 20\text{pF}$ SCIF.OSCCTRL.GAIN = 3			350	
		f = 30MHz, $C_{LEXT} = 18\text{pF}$ SCIF.OSCCTRL.GAIN = 4			45	

Table 9-23. Crystal Oscillator Characteristics

Symbol	Parameter	Conditions	Min	Typ	Max	Unit
C_L	Crystal load capacitance ⁽¹⁾		6		18	pF
C_{SHUNT}	Crystal shunt capacitance ⁽¹⁾				7	
C_{XIN}	Parasitic capacitor load ⁽²⁾	TQFP100 package		4.91		
C_{XOUT}	Parasitic capacitor load ⁽²⁾			3.22		
$t_{STARTUP}$	Startup time ⁽¹⁾	SCIF.OSCCTRL.GAIN = 2		30000 ⁽³⁾		cycles
I_{OSC}	Current consumption ⁽¹⁾	Active mode, f = 0.6MHz, SCIF.OSCCTRL.GAIN = 0		30		μA
		Active mode, f = 4MHz, SCIF.OSCCTRL.GAIN = 1		130		
		Active mode, f = 8MHz, SCIF.OSCCTRL.GAIN = 2		260		
		Active mode, f = 16MHz, SCIF.OSCCTRL.GAIN = 3		590		
		Active mode, f = 30MHz, SCIF.OSCCTRL.GAIN = 4		960		

1. These values are based on simulation. These values are not covered by test limits in production or characterization.
2. These values are based on characterization. These values are not covered by test limits in production.
3. Nominal crystal cycles.

Figure 9-3. Oscillator Connection

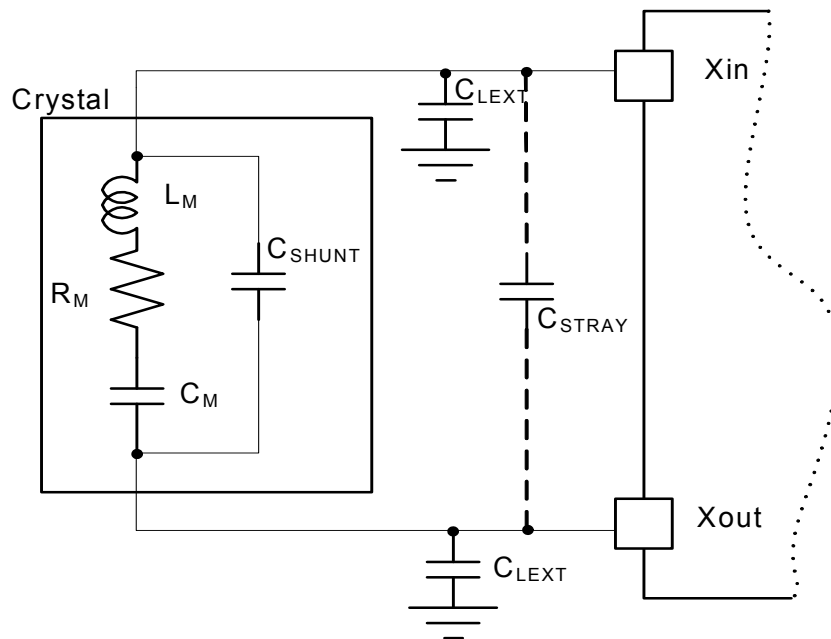

9.7.2 32kHz Crystal Oscillator (OSC32K) Characteristics

Figure 9-3 and the equation above also applies to the 32kHz oscillator connection. The user must choose a crystal oscillator where the crystal load capacitance C_L is within the range given in the table. The exact value of C_L can then be found in the crystal datasheet.

Table 9-24. Digital Clock Characteristics

Symbol	Parameter	Conditions	Min	Typ	Max	Units
$f_{CPXIN32}$	XIN32 clock frequency ⁽¹⁾				6	MHz
	XIN32 clock duty cycle ⁽¹⁾		40		60	%
$t_{STARTUP}$	Startup time			N/A		cycles

1. These values are based on simulation. These values are not covered by test limits in production or characterization.

Table 9-25. 32 kHz Crystal Oscillator Characteristics

Symbol	Parameter	Conditions	Min	Typ	Max	Unit
f_{OUT}	Crystal oscillator frequency			32 768		Hz
$t_{STARTUP}$	Startup time ⁽¹⁾	$R_m = 100k\Omega$, $C_L = 12.5pF$		30000 ⁽²⁾		cycles
C_L	Crystal load capacitance ⁽¹⁾		6		12.5	pF
C_{SHUNT}	Crystal shunt capacitance ⁽¹⁾		0.8		1.7	
C_{XIN}	Parasitic capacitor load ⁽³⁾	TQFP100 package		3.4		
C_{XOUT}	Parasitic capacitor load ⁽³⁾			2.72		
I_{OSC32K}	Current consumption ⁽¹⁾			350		nA
ESR_{XTAL}	Crystal equivalent series resistance ⁽¹⁾ $f=32.768kHz$ OSCCTRL32.MODE=1 Safety Factor = 3	OSCCTRL32.SELCURRE=0	$C_L=6pF$		28	k Ω
		OSCCTRL32.SELCURRE=4			72	
		OSCCTRL32.SELCURRE=8			114	
		OSCCTRL32.SELCURRE=15			313	
	Crystal equivalent series resistance ⁽³⁾ $f=32.768kHz$ OSCCTRL32.MODE=1 Safety Factor = 3	OSCCTRL32.SELCURRE=0	$C_L=9pF$		14	k Ω
		OSCCTRL32.SELCURRE=4			36	
		OSCCTRL32.SELCURRE=8			100	
		OSCCTRL32.SELCURRE=15			170	
	Crystal equivalent series resistance ⁽³⁾ $f=32.768kHz$ OSCCTRL32.MODE=1 Safety Factor = 3	OSCCTRL32.SELCURRE=4	$C_L=12.5pF$		15.2	k Ω
		OSCCTRL32.SELCURRE=6			61.8	
		OSCCTRL32.SELCURRE=8			101.8	
		OSCCTRL32.SELCURRE=10			138.5	
OSCCTRL32.SELCURRE=15				228.5		

1. These values are based on simulation. These values are not covered by test limits in production or characterization.

2. Nominal crystal cycles.

3. These values are based on characterization. These values are not covered by test limits in production.

9.7.3 Phase Locked Loop (PLL) Characteristics

Table 9-26. Phase Locked Loop Characteristics

Symbol	Parameter	Conditions	Min	Typ	Max	Unit
f _{OUT}	Output frequency ⁽¹⁾	PLL is not available in PS1	48		240	MHz
f _{IN}	Input frequency ⁽¹⁾		4		16	
I _{PLL}	Current consumption ⁽¹⁾	f _{out} =80MHz			200	μA
		f _{out} =240MHz			500	
t _{STARTUP}	Startup time, from enabling the PLL until the PLL is locked ⁽¹⁾	Wide Bandwidth mode disabled			8	μs
		Wide Bandwidth mode enabled			30	

1. These values are based on simulation. These values are not covered by test limits in production or characterization.

9.7.4 Digital Frequency Locked Loop (DFLL) Characteristics

Table 9-27. Digital Frequency Locked Loop Characteristics

Symbol	Parameter	Conditions	Min	Typ	Max	Unit
f _{OUT}	Output frequency ⁽¹⁾	DFLL is not available in PS1	20		150	MHz
f _{REF}	Reference frequency ⁽¹⁾		8		150	kHz
	Accuracy ⁽¹⁾	FINE lock, f _{REF} = 32kHz, SSG disabled ⁽²⁾		0.1	0.5	%
		ACCURATE lock, f _{REF} = 32kHz, dither clk RCSYS/2, SSG disabled ⁽²⁾		0.06	0.5	
		FINE lock, f _{REF} = 8-150kHz, SSG disabled ⁽²⁾		0.2	1	
		ACCURATE lock, f _{REF} = 8-150kHz, dither clk RCSYS/2, SSG disabled ⁽²⁾		0.1	1	
I _{DFLL}	Power consumption ⁽¹⁾	RANGE 0 96 to 220MHz COARSE=0, FINE=0, DIV=0	430	509	545	μA
		RANGE 0 96 to 220MHz COARSE=31, FINE=255, DIV=0	1545	1858	1919	
		RANGE 1 50 to 110MHz COARSE=0, FINE=0, DIV=0	218	271	308	
		RANGE 1 50 to 110MHz COARSE=31, FINE=255, DIV=0	704	827	862	
		RANGE 2 25 to 55MHz COARSE=0, FINE=0, DIV=1	140	187	226	
		RANGE 2 25 to 55MHz COARSE=31, FINE=255, DIV=1	365	441	477	
		RANGE 3 20 to 30MHz COARSE=0, FINE=0, DIV=1	122	174	219	
		RANGE 3 20 to 30MHz COARSE=31, FINE=255, DIV=1	288	354	391	

Table 9-27. Digital Frequency Locked Loop Characteristics

Symbol	Parameter	Conditions	Min	Typ	Max	Unit
$t_{STARTUP}$	Startup time ⁽¹⁾	Within 90% of final values			100	μs
t_{LOCK}	Lock time ⁽¹⁾	$f_{REF} = 32kHz$, FINE lock, SSG disabled ⁽²⁾		600		
		$f_{REF} = 32kHz$, ACCURATE lock, dithering clock = RCSYS/2, SSG disabled ⁽²⁾		1100		

1. These values are based on simulation. These values are not covered by test limits in production or characterization.
2. Spread Spectrum Generator (SSG) is disabled by writing a zero to the EN bit in the SCIF.DFLL0SSG register.

9.7.5 32kHz RC Oscillator (RC32K) Characteristics

Table 9-28. 32kHz RC Oscillator Characteristics

Symbol	Parameter	Conditions	Min	Typ	Max	Unit
f_{OUT}	Output frequency ⁽¹⁾	Calibrated against a 32.768kHz reference Temperature compensation disabled	20	32.768	44	kHz
I_{RC32K}	Current consumption ⁽²⁾	Without temperature compensation		0.5		μA
		Temperature compensation enabled		2		μA
$t_{STARTUP}$	Startup time ⁽¹⁾			1		cycle

1. These values are based on characterization. These values are not covered by test limits in production.
2. These values are based on simulation. These values are not covered by test limits in production or characterization.

9.7.6 System RC Oscillator (RCSYS) Characteristics

Table 9-29. System RC Oscillator Characteristics

Symbol	Parameter	Conditions	Min	Typ	Max	Unit
f_{OUT}	Output frequency ⁽¹⁾	Calibrated at 85°C	110	113.6	116	kHz
I_{RCSYS}	Current consumption ⁽²⁾				12	μA
$t_{STARTUP}$	Startup time ⁽¹⁾		25	38	63	μs
Duty	Duty cycle ⁽¹⁾		49.6	50	50.3	%

1. These values are based on characterization. These values are not covered by test limits in production.
2. These values are based on simulation. These values are not covered by test limits in production or characterization.

9.7.7 1MHz RC Oscillator (RC1M) Characteristics

Table 9-30. RC1M Oscillator Characteristics

Symbol	Parameter	Conditions	Min	Typ	Max	Unit
f_{OUT}	Output frequency ⁽¹⁾		0.91	1	1.12	MHz
I_{RC1M}	Current consumption ⁽²⁾			35		μ A
Duty	Duty cycle ⁽¹⁾		48.6	49.9	54.4	%

1. These values are based on characterization. These values are not covered by test limits in production.
2. These values are based on simulation. These values are not covered by test limits in production or characterization.

9.7.8 4/8/12MHz RC Oscillator (RCFAST) Characteristics

Table 9-31. RCFAST Oscillator Characteristics

Symbol	Parameter	Conditions	Min	Typ	Max	Unit
f_{OUT}	Output frequency ⁽¹⁾	Calibrated, FRANGE=0	4	4.3	4.6	MHz
		Calibrated, FRANGE=1	7.8	8.2	8.5	
		Calibrated, FRANGE=2	11.3	12	12.3	
I_{RCFAST}	Current consumption ⁽²⁾	Calibrated, FRANGE=0		90	110	μ A
		Calibrated, FRANGE=1		130	150	
		Calibrated, FRANGE=2		180	205	
Duty	Duty cycle ⁽¹⁾	Calibrated, FRANGE=0	48.8	49.6	50.1	%
		Calibrated, FRANGE=1	47.8	49.2	50.1	
		Calibrated, FRANGE=2	46.7	48.8	50.0	
$t_{STARTUP}$	Startup time ⁽¹⁾	Calibrated, FRANGE=2	0.1	0.31	0.71	μ s

1. These values are based on characterization. These values are not covered by test limits in production.
2. These values are based on simulation. These values are not covered by test limits in production or characterization.

9.7.9 80MHz RC Oscillator (RC80M) Characteristics

Table 9-32. Internal 80MHz RC Oscillator Characteristics

Symbol	Parameter	Conditions	Min	Typ	Max	Unit
f _{OUT}	Output frequency ⁽¹⁾	After calibration Note that RC80M is not available in PS1	60	80	100	MHz
I _{RC80M}	Current consumption ⁽²⁾			330		µA
t _{STARTUP}	Startup time ⁽¹⁾		0.57	1.72	3.2	µs
Duty	Duty cycle ⁽²⁾		45	50	55	%

1. These values are based on characterization. These values are not covered by test limits in production.
2. These values are based on simulation. These values are not covered by test limits in production or characterization.

9.8 Flash Characteristics

Table 9-33 gives the device maximum operating frequency depending on the number of flash wait states and the flash read mode. The FWS bit in the FLASHCALW FCR register controls the number of wait states used when accessing the flash memory.

Table 9-33. Maximum Operating Frequency ⁽¹⁾

PowerScaling Mode	Flash Read Mode	Flash Wait States	Maximum Operating Frequency	Unit
0	Low power (HSDIS) + Flash internal reference: BPM.PMCON.FASTWKUP=1	1	12	MHz
		0	18	
	1	36		
1	Low power (HSDIS) + Flash internal reference: BPM.PMCON.FASTWKUP=1	1	12	
		0	8	
	1	12		
2	High speed (HSEN)	0	24	
		1	48	

1. These values are based on simulation. These values are not covered by test limits in production or characterization.

Table 9-34. Flash Characteristics ⁽¹⁾

Symbol	Parameter	Conditions	Min	Typ	Max	Unit
t _{FPP}	Page programming time	f _{CLK_AHB} = 48MHz		4.38		ms
t _{FPE}	Page erase time			4.38		
t _{FFP}	Fuse programming time			0.63		
t _{FEA}	Full chip erase time (EA)			5.66		
t _{FCE}	JTAG chip erase time (CHIP_ERASE)	f _{CLK_AHB} = 115kHz		304		

1. These values are based on simulation. These values are not covered by test limits in production or characterization.

Table 9-35. Flash Endurance and Data Retention ⁽¹⁾

Symbol	Parameter	Conditions	Min	Typ	Max	Unit
N _{FARRAY}	Array endurance (write/page)	f _{CLK_AHB} > 10MHz	100k			cycles
N _{FFUSE}	General Purpose fuses endurance (write/bit)	f _{CLK_AHB} > 10MHz	10k			
t _{RET}	Data retention		15			years

1. These values are based on simulation. These values are not covered by test limits in production or characterization.

9.9 Analog Characteristics

9.9.1 Voltage Regulator Characteristics

Table 9-36. VREG Electrical Characteristics in Linear and Switching Modes

Symbol	Parameter	Conditions	Min	Typ	Max	Units
I _{OUT}	DC output current ⁽¹⁾ Power scaling mode 0 & 2	Low power mode (WAIT)	2000	3600	5600	μA
		Ultra Low power mode (RETENTION)	100	180	300	
	DC output current ⁽¹⁾ Power scaling mode 1	Low power mode (WAIT)	4000	7000	10000	
		Ultra Low power mode (RETENTION)	200	350	600	
V _{VDDCORE}	DC output voltage	All modes			1.9	V

1. These values are based on simulation. These values are not covered by test limits in production.

Table 9-37. VREG Electrical Characteristics in Linear mode

Symbol	Parameter	Conditions	Min	Typ	Max	Units
V _{VDDIN}	Input voltage range	I _{OUT} =10mA	1.68		3.6	V
		I _{OUT} =50mA	1.8		3.6	
V _{VDDCORE}	DC output voltage ⁽¹⁾ Power scaling mode 0 & 2	I _{OUT} = 0 mA	1.777	1.814	1.854	
		I _{OUT} = 50 mA	1.75	1.79	1.83	
I _{OUT}	DC output current ⁽¹⁾	V _{VDDCORE} > 1.65V			100	mA
	Output DC load regulation ⁽¹⁾ Transient load regulation	I _{OUT} = 0 to 80mA, V _{VDDIN} = 3V	-34	-27	-19	mV
	Output DC regulation ⁽¹⁾	I _{OUT} = 80 mA, V _{VDDIN} = 2V to 3.6V	10	28	48	mV
I _Q	Quiescent current ⁽¹⁾	I _{OUT} = 0 mA RUN and SLEEPx modes	88	107	128	μA

1. These values are based on characterization. These values are not covered by test limits in production.

Table 9-38. External components requirements in Linear Mode

Symbol	Parameter	Technology	Typ	Units
C _{IN1}	Input regulator capacitor 1		33	nF
C _{IN2}	Input regulator capacitor 2		100	
C _{IN3}	Input regulator capacitor 3		10	μF
C _{OUT1}	Output regulator capacitor 1		100	nF
C _{OUT2}	Output regulator capacitor 2	Tantalum or MLCC 0.5<ESR<10Ω	4.7	μF

Table 9-39. VREG Electrical Characteristics in Switching mode

Symbol	Parameter	Conditions	Min	Typ	Max	Units
V _{VDDIN}	Input voltage range	V _{VDDCORE} = 1.65V, I _{OUT} =50mA	2.0		3.6	V
V _{VDDCORE}	DC output voltage ⁽¹⁾ Power scaling mode 0 & 2	I _{OUT} = 0 mA	1.75	1.82	1.87	
		I _{OUT} = 50 mA	1.66	1.71	1.79	

Table 9-39. VREG Electrical Characteristics in Switching mode

Symbol	Parameter	Conditions	Min	Typ	Max	Units
I_{OUT}	DC output current ⁽¹⁾	$V_{VDDCORE} > 1.65V$			55	mA
	Output DC load regulation ⁽¹⁾ Transient load regulation	$I_{OUT} = 0$ to 50 mA, $V_{VDDIN} = 3V$	-136	-101	-82	mV
	Output DC regulation ⁽¹⁾	$I_{OUT} = 50$ mA, $V_{VDDIN} = 2V$ to 3.6V	-20	38	99	mV
I_Q	Quiescent current ⁽¹⁾	$V_{VDDIN} = 2V, I_{OUT} = 0$ mA	97	186	546	μA
		$V_{VDDIN} > 2.2V, I_{OUT} = 0$ mA	97	111	147	
P_{EFF}	Power efficiency ⁽¹⁾	$I_{OUT} = 5mA, 50mA$ Reference power not included	82.7	88.3	95	%

1. These values are based on characterization. These values are not covered by test limits in production.

Table 9-40. Decoupling Requirements in Switching Mode

Symbol	Parameter	Technology	Typ	Units
C_{IN1}	Input regulator capacitor 1		33	nF
C_{IN2}	Input regulator capacitor 2		100	
C_{IN3}	Input regulator capacitor 3		10	μF
C_{OUT1}	Output regulator capacitor 1	X7R MLCC	100	nF
C_{OUT2}	Output regulator capacitor 2	X7R MLCC (ex : GRM31CR71A475)	4.7	μF
L_{EXT}	External inductance	(ex: Murata LQH3NPN220MJ0)	22	μH
R_{DCLEXT}	Serial resistance of L_{EXT}		0.7	Ω
$ISAT_{LEXT}$	Saturation current of L_{EXT}		300	mA

Note: 1. Refer to [Section 6. on page 45.](#)

9.9.2 Power-on Reset 33 Characteristics

Table 9-41. POR33 Characteristics ⁽¹⁾

Symbol	Parameter	Conditions	Min	Typ	Max	Units
V_{POT+}	Voltage threshold on V_{DDIN} rising		1.25		1.55	V
V_{POT-}	Voltage threshold on V_{DDIN} falling		0.95		1.30	

1. These values are based on characterization. These values are not covered by test limits in production.

Figure 9-4. POR33 Operating Principle

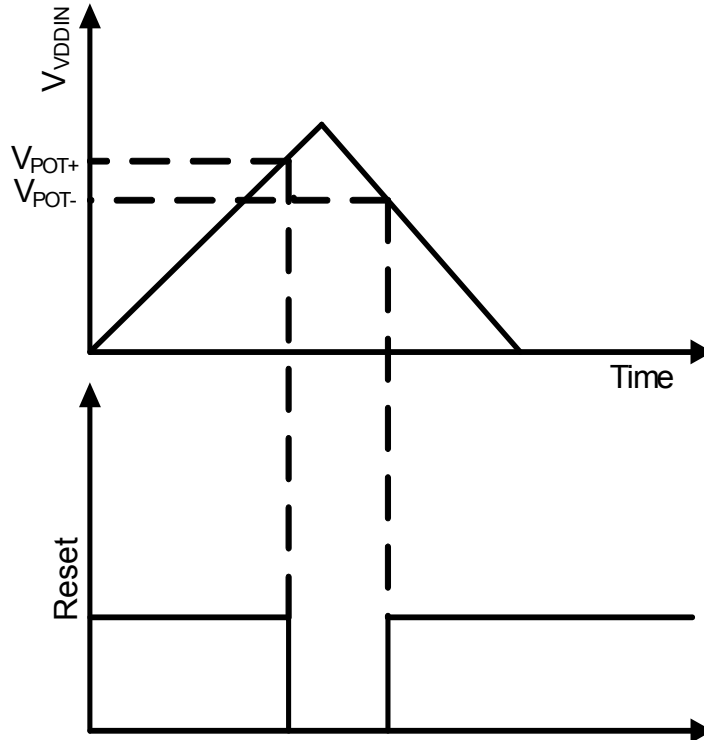

9.9.3 Brown Out Detectors Characteristics

Table 9-42. BOD18 Characteristics ⁽¹⁾

Symbol	Parameter	Conditions	Min	Typ	Max	Units
	Step size, between adjacent values in BSCIF.BOD18LEVEL ⁽¹⁾			10.1		mV
V_{HYST}	BOD hysteresis ⁽¹⁾	$T = 25^{\circ}C$	3		40	
t_{DET}	Detection time ⁽¹⁾	Time with $V_{VDDCORE} < BOD18.LEVEL$ necessary to generate a reset signal	1.2			μs
I_{BOD}	Current consumption ⁽¹⁾	on VDDIN		7.4	14	μA
		on VDDCORE			7	
$t_{STARTUP}$	Startup time ⁽¹⁾				4.5	μs

1. These values are based on simulation. These values are not covered by test limits in production or characterization.

The values in [Table 9-43](#) describe the values of the BOD33.LEVEL in the flash User Page fuses.

Table 9-43. BOD33.LEVEL Values

BOD33.LEVEL Value	Min	Typ	Max	Units
16		2.08		V
20		2.18		
24		2.33		
28		2.48		
32		2.62		
36		2.77		
40		2.92		
44		3.06		
48		3.21		

Table 9-44. BOD33 Characteristics ⁽¹⁾

Symbol	Parameter	Conditions	Min	Typ	Max	Units
	Step size, between adjacent values in BSCIF.BOD33LEVEL ⁽¹⁾			3.44		mV
V _{HYST}	Hysteresis ⁽¹⁾		45		170	
t _{DET}	Detection time ⁽¹⁾	Time with VDDIN < V _{TH} necessary to generate a reset signal				μs
I _{BOD33}	Current consumption ⁽¹⁾	Normal mode			36	μA
t _{STARTUP}	Startup time ⁽¹⁾	Normal mode			6	μs

1. These values are based on simulation. These values are not covered by test limits in production or characterization.

9.9.4 Analog- to Digital Converter Characteristics

Table 9-45. Operating conditions

Symbol	Parameter	Conditions	Min	Typ	Max	Units
	Temperature range		-40		+85	°C
	Resolution ⁽¹⁾	Max		12	12 ⁽²⁾	Bit
	Sampling clock ⁽³⁾	Differential modes, Gain=1X	5		300	kHz
		Unipolar modes, Gain=1X	5		250	
f _{ADC}	ADC clock frequency ⁽³⁾	Differential modes	0.03		1.8	MHz
		Unipolar modes	0.03		1.5	
T _{SAMPLEHOLD}	Sampling time ⁽³⁾	Differential modes	16.5		277	µs
		Unipolar modes	16.5		333	
	Conversion rate ⁽¹⁾	1X gain, differential			300	kSps
	Internal channel conversion rate ⁽³⁾	V _{VDD} /10, Bandgap and Temperature channels			125	kSps
	Conversion time (latency) Differential mode (no windowing)	1X gain, (resolution/2)+gain ⁽⁴⁾			6	Cycles
		2X and 4X gain			7	
		8X and 16X gain			8	
		32X and 64X gain			9	
		64X gain and unipolar			10	

1. These values are based on characterization. These values are not covered by test limits in production
2. Single ended or using divide by two max resolution: 11 bits
3. These values are based on simulation. These values are not covered by test limits in production
4. See [Figure 9-5](#)

Figure 9-5. Maximum input common mode voltage

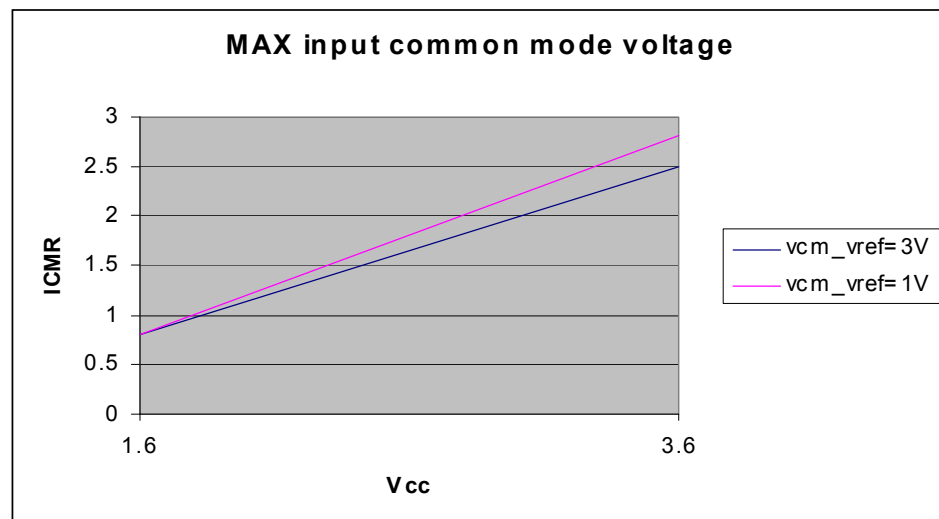

Table 9-46. DC Characteristics

Symbol	Parameter	Conditions	Min	Typ	Max	Units
VDDANA	Supply voltage ⁽¹⁾		1.6		3.6	V
	Reference range ⁽²⁾	Differential mode	1.0		VDDANA -0.6	V
		Unipolar and Window modes	1.0		1.0	
		Using divide by two function (differential)			VDDANA	
	Absolute min, max input voltage ⁽²⁾		-0,1		VDDANA +0.1	V
	Start up time ⁽²⁾	ADC with reference already enabled		12	24	Cycles
		No gain compensation Reference buffer			5	µs
		Gain compensation Reference buffer			60	Cycles
R _{SAMPLE}	Input channel source resistance ⁽²⁾				0.5	kΩ
C _{SAMPLE}	Sampling capacitance ⁽²⁾		2.9	3.6	4.3	pF
	Reference input source resistance ⁽²⁾	Gain compensation			2	kΩ
		No gain compensation			1	MΩ
	ADC reference settling time ⁽²⁾	After changing reference/mode ⁽³⁾		5	60	Cycles

1. These values are based on characterization. These values are not covered by test limits in production
2. These values are based on simulation. These values are not covered by test limits in production
3. Requires refresh/flush otherwise conversion time (latency) + 1

Table 9-47. Differential mode, gain=1

Symbol	Parameter	Conditions	Min	Typ	Max	Units
	Accuracy without compensation ⁽¹⁾			7		ENOB
	Accuracy after compensation ⁽¹⁾	(INL, gain and offset)			11	ENOB
INL	Integral Non Linearity ⁽²⁾	After calibration, Gain compensation		1.2	1.7	LSBs
DNL	Differential Non Linearity ⁽²⁾	After calibration		0.7	1.0	LSBs
	Gain error ⁽²⁾	External reference	-5.0	-1.0	5.0	mV
		VDDANA/1.6	-40		40	
		VDDANA/2.0	-40		40	
		Bandgap After calibration	-30		30	
	Gain error drift vs voltage ⁽¹⁾	External reference	-2		2	mV/V
	Gain error drift vs temperature ⁽¹⁾	After calibration + bandgap drift If using onchip bandgap			0.08	mV/°K
	Offset error ⁽²⁾	External reference	-5.0		5.0	mV
		VDDANA/1.6	-10		10	
		VDDANA/2.0	-10		10	
		Bandgap After calibration	-10		10	
	Offset error drift vs voltage ⁽¹⁾		-4		4	mV/V

Table 9-47. Differential mode, gain=1

	Offset error drift vs temperature ⁽¹⁾				0.04	mV/°K
	Conversion range ⁽²⁾	Vin-Vip	-Vref		Vref	V
	ICMR ⁽¹⁾			see Figure 9-5		
	PSRR ⁽¹⁾	f _{vdd} =1Hz, ext ADVREFP=3.0V V _{VDD} =3.6V		100		dB
		f _{vdd} =2MHz, ext ADVREFP=3.0V V _{VDD} =3.6		50		
	DC supply current ⁽²⁾	VDDANA=3.6V, ADVREFP=3.0V		1.2		mA
		VDDANA=1.6V, ADVREFP=1.0V		0.6		

1. These values are based on simulation only. These values are not covered by test limits in production or characterization
2. These values are based on characterization and not tested in production, and valid for an input voltage between 10% to 90% of reference voltage.

Table 9-48. Unipolar mode, gain=1

Symbol	Parameter	Conditions	Min	Typ	Max	Units
	Accuracy without compensation ⁽¹⁾			7		ENOB
	Accuracy after compensation ⁽¹⁾				11	ENOB
INL	Integral Non Linearity ⁽²⁾	After calibration Dynamic tests No gain compensation			±3	LSBs
		After calibration Dynamic tests Gain compensation			±3	
DNL	Differential Non Linearity ⁽²⁾	After calibration			±2.8	LSBs
	Gain error ⁽²⁾	External reference	-15		15	mV
		VDDANA/1.6	-50		50	
		VDDANA/2.0	-30		30	
		Bandgap After calibration	-10		10	
	Gain error drift vs voltage ⁽¹⁾	External reference	-8		8	mV/V
	Gain error drift temperature ⁽¹⁾	+ bandgap drift If using bandgap			0.08	mV/°K
	Offset error ⁽²⁾	External reference	-15		15	mV
		VDDANA/1.6	-15		15	
		VDDANA/2.0	-15		15	
		Bandgap After calibration	-10		10	
	Offset error drift ⁽¹⁾		-4		4	mV/V
	Offset error drift temperature ⁽¹⁾			0	0.04	mV/°K
	Conversion range ⁽¹⁾	Vin-Vip	-Vref		Vref	V
	ICMR ⁽¹⁾			see Figure 9-5		

Table 9-48. Unipolar mode, gain=1

	PSRR ⁽¹⁾	fvdd=1Hz, ext ADVREFP=3.0V VDDIO=3.6V	100		dB
		fvdd=2MHz, ext ADVREFP=3.0V VDDIO=3.6V	50		
	DC supply current ⁽¹⁾	VDDANA=3.6V, ADVREFP=3.0V	1	1.8	mA
		VDDANA=1.6V, ADVREFP=1.0V	1	1.3	

1. These values are based on simulation. These values are not covered by test limits in production or characterization.
2. These values are based on characterization and not tested in production, and valid for an input voltage between 10% to 90% of reference voltage.

9.9.4.1 Inputs and Sample and Hold Acquisition Times

The analog voltage source must be able to charge the sample and hold (S/H) capacitor in the ADC in order to achieve maximum accuracy. Seen externally the ADC input consists of a resistor (R_{SAMPLE}) and a capacitor (C_{SAMPLE}). In addition, the source resistance (R_{SOURCE}) must be taken into account when calculating the required sample and hold time. Figure 9-6 shows the ADC input channel equivalent circuit.

Figure 9-6. ADC Input

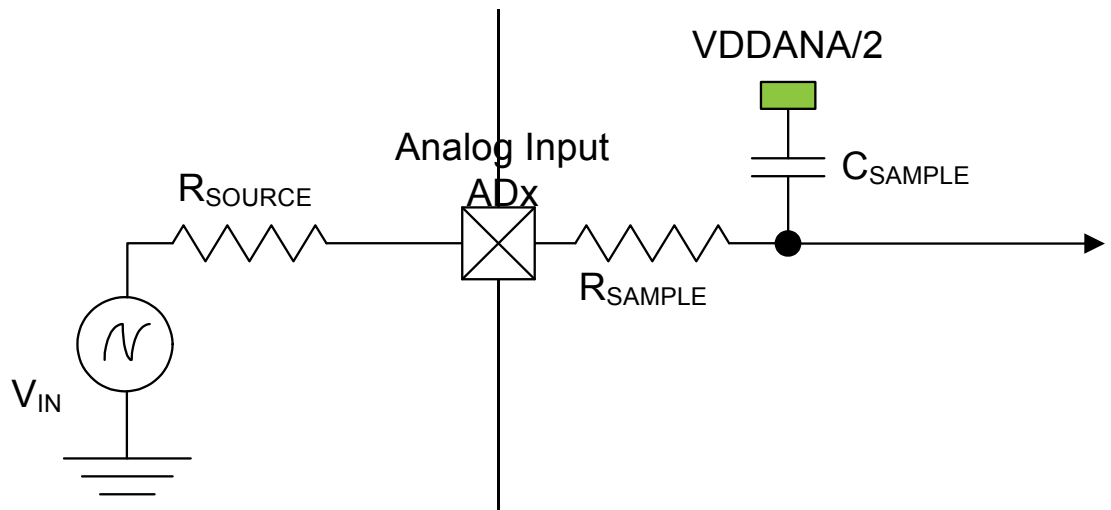

To achieve n bits of accuracy, the C_{SAMPLE} capacitor must be charged at least to a voltage of

$$V_{CSAMPLE} \geq V_{IN} \times (1 - 2^{-(n+1)})$$

The minimum sampling time $t_{SAMPLEHOLD}$ for a given R_{SOURCE} can be found using this formula:

$$t_{SAMPLEHOLD} \geq (R_{SAMPLE} + R_{SOURCE}) \times (C_{SAMPLE}) \times (n + 1) \times \ln(2)$$

for a 12 bits accuracy : $t_{SAMPLEHOLD} \geq (R_{SAMPLE} + R_{SOURCE}) \times (C_{SAMPLE}) \times 9,02$

where

$$t_{SAMPLEHOLD} = \frac{1}{2 \times f_{ADC}}$$

9.9.5 Digital to Analog Converter Characteristics

Table 9-49. Operating conditions

Symbol	Parameter	Conditions	Min	Typ	Max	Units
	Analog Supply Voltage ⁽¹⁾	on VDDANA	2.4	3	3.6	V
	Digital Supply Voltage ⁽¹⁾	on VDDCORE	1.62	1.8	1.98	V
	Resolution ⁽²⁾			10		bits
	Clock frequency ⁽¹⁾	Cload = 50pF ; Rload = 5kΩ			500	kHz
	Load ⁽¹⁾	Cload			50	pF
		Rload	5			kΩ
INL	Integral Non Linearity ⁽¹⁾	Best fit-line method			±2	LSBs
DNL	Differential Non Linearity ⁽¹⁾	Best fit-line method	-0.9		+1	LSBs
	Zero Error (offset) ⁽¹⁾	CDR[9:0] = 0		1	5	mV
	Gain Error ⁽¹⁾	CDR[9:0] = 1023		5	10	mV
	Total Harmonic Distortion ⁽¹⁾	80% of VDDANA @ fin = 70kHz	-56		7	dB
	Delay to vout ⁽¹⁾	CDR[9:0] = 512/ Cload = 50 pF / Rload = 5 kΩ	2			μs
	Startup time ⁽¹⁾	CDR[9:0] = 512	5		9	μs
	Output Voltage Range	(ADVREFP < VDDANA – 100mV) is mandatory	0		ADVREFP	V
	ADVREFP Voltage Range ⁽¹⁾	(ADVREFP < VDDANA – 100mV) is mandatory	2.3		3.5	V
	ADVREFN Voltage Range ⁽¹⁾	ADVREFP = GND		0		V
	Standby Current ⁽¹⁾	On VDDANA			500	nA
		On VDDCORE			100	
	DC Current consumption ⁽¹⁾	On VDDANA (no Rload)		485	660	μA
		On ADVREFP (CDR[9:0] = 512)		250	295	

1. These values are based on simulation. These values are not covered by test limits in production or characterization
2. These values are based on characterization. These values are not covered by test limits in production

9.9.6 Analog Comparator Characteristics

Table 9-50. Analog Comparator Characteristics

Symbol	Parameter	Conditions	Min	Typ	Max	Units
	Positive input voltage range		0.1		VDDIO-0.1	V
	Negative input voltage range		0.1		VDDIO-0.1	
	Offset ⁽¹⁾	V _{ACREFN} = 0.1V to VDDIO-0.1V, hysteresis = 0 ⁽²⁾ Fast mode	-12		13	mV
		V _{ACREFN} = 0.1V to VDDIO-0.1V, hysteresis = 0 ⁽²⁾ Low power mode	-11		12	mV

Table 9-50. Analog Comparator Characteristics

Symbol	Parameter	Conditions	Min	Typ	Max	Units
	Hysteresis ⁽¹⁾	V _{ACREFN} =0.1V to VDDIO-0.1V, hysteresis = 1 ⁽²⁾ Fast mode	10		55	mV
		V _{ACREFN} =0.1V to VDDIO-0.1V, hysteresis = 1 ⁽²⁾ Low power mode	10		68	mV
		V _{ACREFN} =0.1V to VDDIO-0.1V, hysteresis = 2 ⁽²⁾ Fast mode	26		83	mV
		V _{ACREFN} =0.1V to VDDIO-0.1V, hysteresis = 2 ⁽²⁾ Low power mode	19		91	mV
		V _{ACREFN} =0.1V to VDDIO-0.1V, hysteresis = 3 ⁽²⁾ Fast mode	43		106	mV
		V _{ACREFN} =0.1V to VDDIO-0.1V, hysteresis = 3 ⁽²⁾ Low power mode	32		136	mV
	Propagation delay ⁽¹⁾	Changes for V _{ACM} =VDDIO/2 100mV Overdrive Fast mode			67	ns
		Changes for V _{ACM} =VDDIO/2 100mV Overdrive Low power mode			315	ns
t _{STARTUP}	Startup time ⁽¹⁾	Enable to ready delay Fast mode			1.19	μs
		Enable to ready delay Low power mode			3.61	μs
I _{AC}	Channel current consumption ⁽³⁾	Low power mode, no hysteresis		4.9	8.7	μA
		Fast mode, no hysteresis		63	127	

1. These values are based on characterization. These values are not covered by test limits in production
2. HYSTAC.CONFn.HYS field, refer to the Analog Comparator Interface chapter
3. These values are based on simulation. These values are not covered by test limits in production or characterization

9.9.7 Liquid Crystal Display Controller characteristics

Table 9-51. Liquid Crystal Display Controller characteristics

Symbol	Parameter	Conditions	Min	Typ	Max	Units
SEG	Segment Terminal Pins				40	
COM	Common Terminal Pins				4	
f_{Frame}	LCD Frame Frequency	F_{CLKLCD}	31.25		512	Hz
C_{Flying}	Flying Capacitor			100		nF
V_{LCD}	LCD Regulated Voltages ⁽¹⁾ CFG.FCST=0	$C_{Flying} = 100nF$ 100nF on V_{LCD} , BIAS2 and BIAS1 pins		3		V
BIAS2				$2*V_{LCD}/3$		
BIAS1				$V_{LCD}/3$		

1. These values are based on simulation. These values are not covered by test limits in production or characterization

9.9.7.1 Liquid Crystal Controller supply current

The values in [Table 9-52](#) are measured values of power consumption under the following conditions, except where noted:

- T=25°C, WAIT mode, Low power waveform, Frame Rate = 32Hz from OSC32K
- Configuration: 4COMx40SEG, 1/4 Duty, 1/3 Bias, No animation
- All segments on, Load = 160 x 22pF between each COM and each SEG.
- LCDCA current based on $I_{LCD} = I_{WAIT}(Lcd\ On) - I_{WAIT}(Lcd\ Off)$

Table 9-52. Liquid Crystal Display Controller supply current

Symbol	Conditions	Min	Typ	Max	Units
I_{LCD}	Internal voltage generation CFG.FCST=0	$V_{VDDIN} = 3.6V$		8.85	μA
		$V_{VDDIN} = 1.8V$		6.16	
	External bias $V_{LCD}=3.0V$	$V_{VDDIN} = 3.3V$		0.98	
		$V_{VDDIN} = 1.8V$		1.17	

9.10 Timing Characteristics

9.10.1 RESET_N Timing

Table 9-53. RESET_N Waveform Parameters ⁽¹⁾

Symbol	Parameter	Conditions	Min	Max	Units
t_{RESET}	RESET_N minimum pulse length		10		ns

1. These values are based on simulation. These values are not covered by test limits in production.

9.10.2 USART in SPI Mode Timing

9.10.2.1 Master mode

Figure 9-7. USART in SPI Master Mode with (CPOL= CPHA= 0) or (CPOL= CPHA= 1)

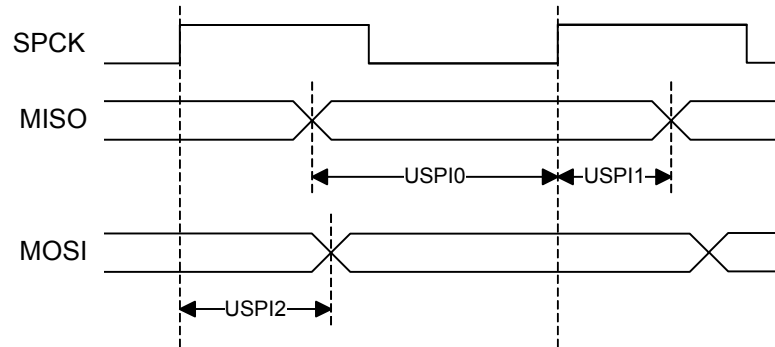

Figure 9-8. USART in SPI Master Mode with (CPOL= 0 and CPHA= 1) or (CPOL= 1 and CPHA= 0)

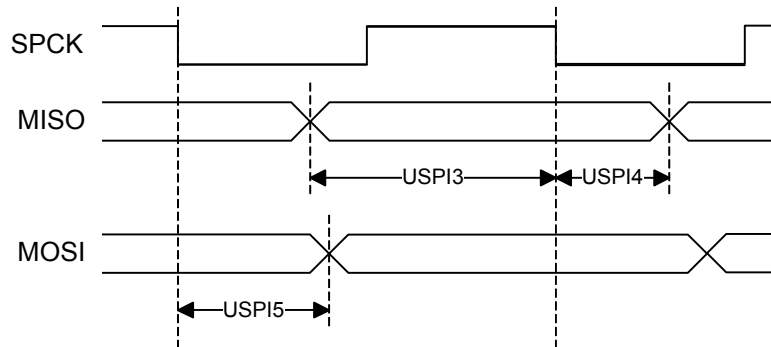

Table 9-54. USART0 in SPI Mode Timing, Master Mode⁽¹⁾

Symbol	Parameter	Conditions	Min	Max	Units
USPI0	MISO setup time before SPCK rises	V _{VDDIO} from 3.0V to 3.6V, maximum external capacitor = 40pF	123.2 + t _{SAMPLE} ⁽²⁾		ns
USPI1	MISO hold time after SPCK rises		24.74 - t _{SAMPLE} ⁽²⁾		
USPI2	SPCK rising to MOSI delay			513.56	
USPI3	MISO setup time before SPCK falls		125.99 + t _{SAMPLE} ⁽²⁾		
USPI4	MISO hold time after SPCK falls		24.74 - t _{SAMPLE} ⁽²⁾		
USPI5	SPCK falling to MOSI delay			516.55	

Table 9-55. USART1 in SPI Mode Timing, Master Mode⁽¹⁾

Symbol	Parameter	Conditions	Min	Max	Units
USPI0	MISO setup time before SPCK rises	V _{VDDIO} from 3.0V to 3.6V, maximum external capacitor = 40pF	69.28 + t _{SAMPLE} ⁽²⁾		ns
USPI1	MISO hold time after SPCK rises		25.75 - t _{SAMPLE} ⁽²⁾		
USPI2	SPCK rising to MOSI delay			99.66	
USPI3	MISO setup time before SPCK falls		73.12 + t _{SAMPLE} ⁽²⁾		
USPI4	MISO hold time after SPCK falls		28.10 - t _{SAMPLE} ⁽²⁾		
USPI5	SPCK falling to MOSI delay			102.01	

Table 9-56. USART2 in SPI Mode Timing, Master Mode⁽¹⁾

Symbol	Parameter	Conditions	Min	Max	Units
USPI0	MISO setup time before SPCK rises	V _{VDDIO} from 3.0V to 3.6V, maximum external capacitor = 40pF	69.09 + t _{SAMPLE} ⁽²⁾		ns
USPI1	MISO hold time after SPCK rises		26.52 - t _{SAMPLE} ⁽²⁾		
USPI2	SPCK rising to MOSI delay			542.96	
USPI3	MISO setup time before SPCK falls		72.55 + t _{SAMPLE} ⁽²⁾		
USPI4	MISO hold time after SPCK falls		28.37 - t _{SAMPLE} ⁽²⁾		
USPI5	SPCK falling to MOSI delay			544.80	

Table 9-57. USART3 in SPI Mode Timing, Master Mode⁽¹⁾

Symbol	Parameter	Conditions	Min	Max	Units
USPI0	MISO setup time before SPCK rises	V _{VDDIO} from 3.0V to 3.6V, maximum external capacitor = 40pF	147.24 + t _{SAMPLE} ⁽²⁾		ns
USPI1	MISO hold time after SPCK rises		25.80 - t _{SAMPLE} ⁽²⁾		
USPI2	SPCK rising to MOSI delay			88.23	
USPI3	MISO setup time before SPCK falls		154.9 + t _{SAMPLE} ⁽²⁾		
USPI4	MISO hold time after SPCK falls		26.89 - t _{SAMPLE} ⁽²⁾		
USPI5	SPCK falling to MOSI delay			89.32	

Notes: 1. These values are based on simulation. These values are not covered by test limits in production.

2. Where: $t_{SAMPLE} = t_{SPCK} - \left(\left\lfloor \frac{t_{SPCK}}{2 \times t_{CLKUSART}} \right\rfloor \right) \times t_{CLKUSART}$

Maximum SPI Frequency, Master Output

The maximum SPI master output frequency is given by the following formula:

$$f_{SPCKMAX} = \text{MIN}(f_{PINMAX}, \frac{1}{SPI_n}, \frac{f_{CLKSPI} \times 2}{9})$$

Where SPI_n is the MOSI delay, USPI2 or USPI5 depending on CPOL and NCPHA. f_{PINMAX} is the maximum frequency of the SPI pins. refer to the I/O Pin Characteristics section for the maximum frequency of the pins. f_{CLKSPI} is the maximum frequency of the CLK_SPI. Refer to the SPI chapter for a description of this clock.

Maximum SPI Frequency, Master Input

The maximum SPI master input frequency is given by the following formula:

$$f_{SPCKMAX} = \text{MIN}(\frac{1}{SPI_n + t_{VALID}}, \frac{f_{CLKSPI} \times 2}{9})$$

Where SPI_n is the MISO setup and hold time, USPI0 + USPI1 or USPI3 + USPI4 depending on CPOL and NCPHA. t_{VALID} is the SPI slave response time. refer to the SPI slave datasheet for $t_{VALID} \cdot f_{CLKSPI}$ is the maximum frequency of the CLK_SPI. Refer to the SPI chapter for a description of this clock.

9.10.2.2 Slave mode

Figure 9-9. USART in SPI Slave Mode with (CPOL= 0 and CPHA= 1) or (CPOL= 1 and CPHA= 0)

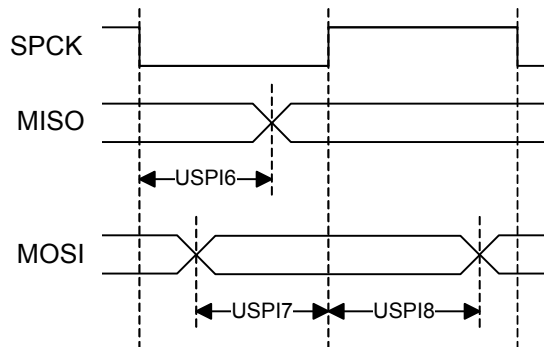

Figure 9-10. USART in SPI Slave Mode with (CPOL= CPHA= 0) or (CPOL= CPHA= 1)

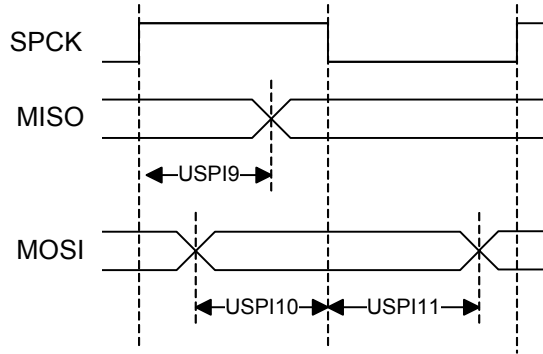

Figure 9-11. USART in SPI Slave Mode, NPCS Timing

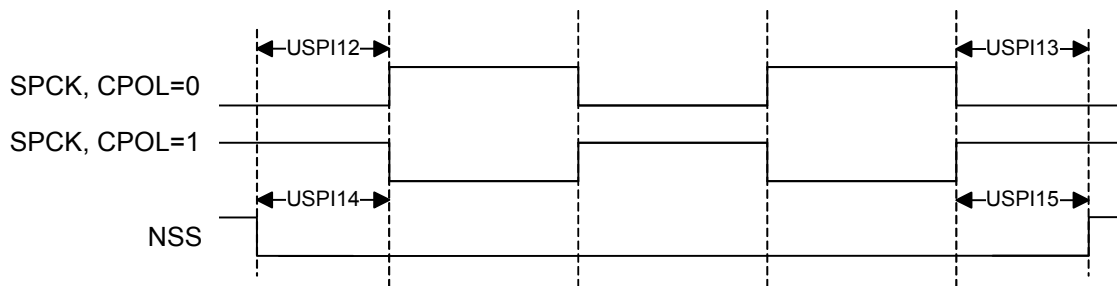

Table 9-58. USART0 in SPI mode Timing, Slave Mode⁽¹⁾

Symbol	Parameter	Conditions	Min	Max	Units
USPI6	SPCK falling to MISO delay	V _{VDDIO} from 3.0V to 3.6V, maximum external capacitor = 40pF		740.67	ns
USPI7	MOSI setup time before SPCK rises		$56.73 + t_{SAMPLE}^{(2)} + t_{CLK_USART}$		
USPI8	MOSI hold time after SPCK rises		$45.18 - (t_{SAMPLE}^{(2)} + t_{CLK_USART})$		
USPI9	SPCK rising to MISO delay			670.18	
USPI10	MOSI setup time before SPCK falls		$56.73 + (t_{SAMPLE}^{(2)} + t_{CLK_USART})$		
USPI11	MOSI hold time after SPCK falls		$45.18 - (t_{SAMPLE}^{(2)} + t_{CLK_USART})$		
USPI12	NSS setup time before SPCK rises		688.71		
USPI13	NSS hold time after SPCK falls		-2.25		
USPI14	NSS setup time before SPCK falls		688.71		
USPI15	NSS hold time after SPCK rises		-2.25		

Table 9-59. USART1 in SPI mode Timing, Slave Mode⁽¹⁾

Symbol	Parameter	Conditions	Min	Max	Units
USPI6	SPCK falling to MISO delay	V _{VDDIO} from 3.0V to 3.6V, maximum external capacitor = 40pF		373.58	ns
USPI7	MOSI setup time before SPCK rises		$4.16 + t_{\text{SAMPLE}}^{(2)} + t_{\text{CLK_USART}}$		
USPI8	MOSI hold time after SPCK rises		$46.69 - (t_{\text{SAMPLE}}^{(2)} + t_{\text{CLK_USART}})$		
USPI9	SPCK rising to MISO delay			373.54	
USPI10	MOSI setup time before SPCK falls		$4.16 + (t_{\text{SAMPLE}}^{(2)} + t_{\text{CLK_USART}})$		
USPI11	MOSI hold time after SPCK falls		$46.69 - (t_{\text{SAMPLE}}^{(2)} + t_{\text{CLK_USART}})$		
USPI12	NSS setup time before SPCK rises		200.43		
USPI13	NSS hold time after SPCK falls		-16.5		
USPI14	NSS setup time before SPCK falls		200.43		
USPI15	NSS hold time after SPCK rises		-16.5		

Table 9-60. USART2 in SPI mode Timing, Slave Mode⁽¹⁾

Symbol	Parameter	Conditions	Min	Max	Units
USPI6	SPCK falling to MISO delay	V _{VDDIO} from 3.0V to 3.6V, maximum external capacitor = 40pF		770.02	ns
USPI7	MOSI setup time before SPCK rises		$136.56 + t_{\text{SAMPLE}}^{(2)} + t_{\text{CLK_USART}}$		
USPI8	MOSI hold time after SPCK rises		$47.9 - (t_{\text{SAMPLE}}^{(2)} + t_{\text{CLK_USART}})$		
USPI9	SPCK rising to MISO delay			570.19	
USPI10	MOSI setup time before SPCK falls		$136.73 + (t_{\text{SAMPLE}}^{(2)} + t_{\text{CLK_USART}})$		
USPI11	MOSI hold time after SPCK falls		$47.9 - (t_{\text{SAMPLE}}^{(2)} + t_{\text{CLK_USART}})$		
USPI12	NSS setup time before SPCK rises		519.87		
USPI13	NSS hold time after SPCK falls		-1.83		
USPI14	NSS setup time before SPCK falls		519.87		
USPI15	NSS hold time after SPCK rises		-1.83		

Table 9-61. USART3 in SPI mode Timing, Slave Mode⁽¹⁾

Symbol	Parameter	Conditions	Min	Max	Units
USPI6	SPCK falling to MISO delay	V _{VDDIO} from 3.0V to 3.6V, maximum external capacitor = 40pF		593.9	ns
USPI7	MOSI setup time before SPCK rises		45.93 + t _{SAMPLE} ⁽²⁾ + t _{CLK_USART}		
USPI8	MOSI hold time after SPCK rises		47.03 - (t _{SAMPLE} ⁽²⁾ + t _{CLK_USART})		
USPI9	SPCK rising to MISO delay			593.38	
USPI10	MOSI setup time before SPCK falls		45.93 + (t _{SAMPLE} ⁽²⁾ + t _{CLK_USART})		
USPI11	MOSI hold time after SPCK falls		47.03 - (t _{SAMPLE} ⁽²⁾ + t _{CLK_USART})		
USPI12	NSS setup time before SPCK rises		237.5		
USPI13	NSS hold time after SPCK falls		-1.81		
USPI14	NSS setup time before SPCK falls		237.5		
USPI15	NSS hold time after SPCK rises		-1.81		

Notes: 1. These values are based on simulation. These values are not covered by test limits in production.

2. Where: $t_{SAMPLE} = t_{SPCK} - \left(\left\lfloor \frac{t_{SPCK}}{2 \times t_{CLKUSART}} \right\rfloor + \frac{1}{2} \right) \times t_{CLKUSART}$

Maximum SPI Frequency, Slave Input Mode

The maximum SPI slave input frequency is given by the following formula:

$$f_{SPCKMAX} = \text{MIN} \left(\frac{f_{CLKSPI} \times 2}{9}, \frac{1}{SPI_{In}} \right)$$

Where SPI_{In} is the MOSI setup and hold time, USPI7 + USPI8 or USPI10 + USPI11 depending on CPOL and NCPHA. f_{CLKSPI} is the maximum frequency of the CLK_SPI. Refer to the SPI chapter for a description of this clock.

Maximum SPI Frequency, Slave Output Mode

The maximum SPI slave output frequency is given by the following formula:

$$f_{SPCKMAX} = \text{MIN} \left(\frac{f_{CLKSPI} \times 2}{9}, f_{PINMAX}, \frac{1}{SPI_{In} + t_{SETUP}} \right)$$

Where SPI_{In} is the MISO delay, USPI6 or USPI9 depending on CPOL and NCPHA. T_{SETUP} is the SPI master setup time. refer to the SPI master datasheet for T_{SETUP} . f_{CLKSPI} is the maximum frequency of the CLK_SPI. Refer to the SPI chapter for a description of this clock. f_{PINMAX} is the maximum frequency of the SPI pins. refer to the I/O Pin Characteristics section for the maximum frequency of the pins.

9.10.3 SPI Timing

9.10.3.1 Master mode

Figure 9-12. SPI Master Mode with (CPOL= NCPHA= 0) or (CPOL= NCPHA= 1)

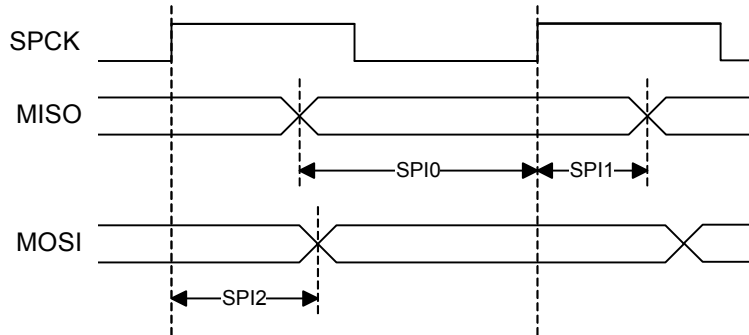

Figure 9-13. SPI Master Mode with (CPOL= 0 and NCPHA= 1) or (CPOL= 1 and NCPHA= 0)

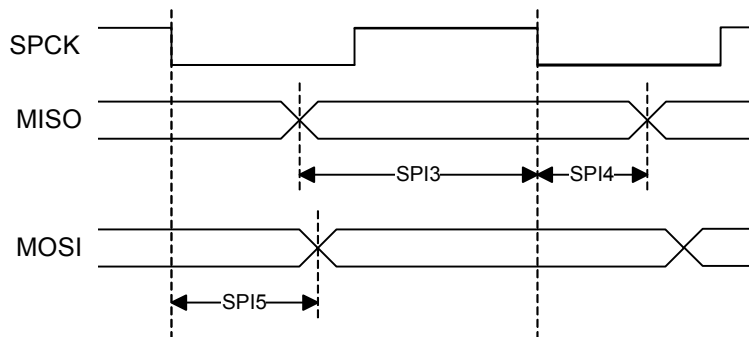

Table 9-62. SPI Timing, Master Mode⁽¹⁾

Symbol	Parameter	Conditions	Min	Max	Units
SPI0	MISO setup time before SPCK rises	V _{VDDIO} from 3.0V to 3.6V, maximum external capacitor = 40pF	$72.8 + (t_{CLK_SPI})/2$		ns
SPI1	MISO hold time after SPCK rises		22.7		
SPI2	SPCK rising to MOSI delay			47.4	
SPI3	MISO setup time before SPCK falls		$76.5 + (t_{CLK_SPI})/2$		
SPI4	MISO hold time after SPCK falls		20.6		
SPI5	SPCK falling to MOSI delay			49.5	

Note: 1. These values are based on simulation. These values are not covered by test limits in production.

Maximum SPI Frequency, Master Output

The maximum SPI master output frequency is given by the following formula:

$$f_{SPCKMAX} = \text{MIN}(f_{PINMAX}, \frac{1}{SPI_{in}})$$

Where SPI_{in} is the MOSI delay, SPI2 or SPI5 depending on CPOL and NCPHA. f_{PINMAX} is the maximum frequency of the SPI pins. refer to the I/O Pin Characteristics section for the maximum frequency of the pins.

Maximum SPI Frequency, Master Input

The maximum SPI master input frequency is given by the following formula:

$$f_{SPCKMAX} = \frac{1}{SPI_{in} + t_{VALID}}$$

Where SPI_{in} is the MISO setup and hold time, SPI0 + SPI1 or SPI3 + SPI4 depending on CPOL and NCPHA. t_{VALID} is the SPI slave response time. refer to the SPI slave datasheet for t_{VALID} .

9.10.3.2 Slave mode

Figure 9-14. SPI Slave Mode with (CPOL= 0 and NCPHA= 1) or (CPOL= 1 and NCPHA= 0)

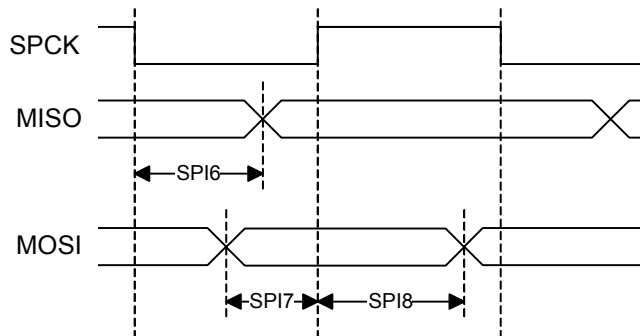

Figure 9-15. SPI Slave Mode with (CPOL= NCPHA= 0) or (CPOL= NCPHA= 1)

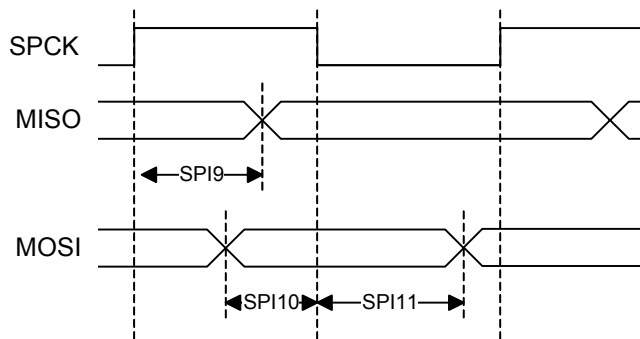

Figure 9-16. SPI Slave Mode, NPCS Timing

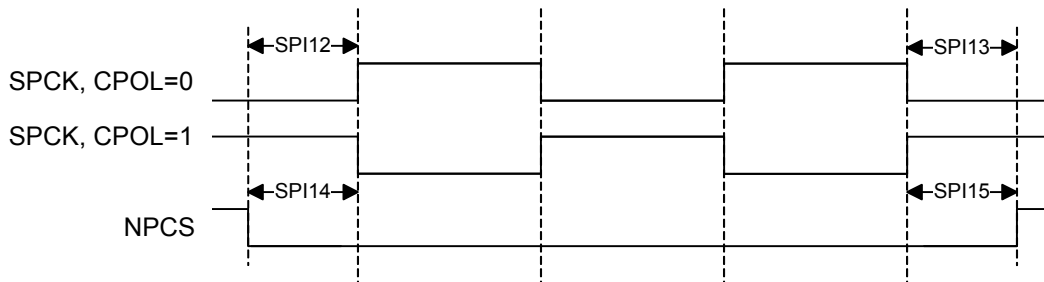

Table 9-63. SPI Timing, Slave Mode⁽¹⁾

Symbol	Parameter	Conditions	Min	Max	Units
SPI6	SPCK falling to MISO delay	V _{VDDIO} from 3.0V to 3.6V, maximum external capacitor = 40pF		79	ns
SPI7	MOSI setup time before SPCK rises		2.1		
SPI8	MOSI hold time after SPCK rises		7.3		
SPI9	SPCK rising to MISO delay			80	
SPI10	MOSI setup time before SPCK falls		1		
SPI11	MOSI hold time after SPCK falls		6		
SPI12	NPCS setup time before SPCK rises		4		
SPI13	NPCS hold time after SPCK falls		1		
SPI14	NPCS setup time before SPCK falls		4.1		
SPI15	NPCS hold time after SPCK rises		1.4		

Note: 1. These values are based on simulation. These values are not covered by test limits in production.

Maximum SPI Frequency, Slave Input Mode

The maximum SPI slave input frequency is given by the following formula:

$$f_{SPCKMAX} = MIN(f_{CLKSPI}, \frac{1}{SPI_{In}})$$

Where *SPI_{In}* is the MOSI setup and hold time, SPI7 + SPI8 or SPI10 + SPI11 depending on CPOL and NCPHA. *f_{CLKSPI}* is the maximum frequency of the CLK_SPI. Refer to the SPI chapter for a description of this clock.

Maximum SPI Frequency, Slave Output Mode

The maximum SPI slave output frequency is given by the following formula:

$$f_{SPCKMAX} = MIN(f_{PINMAX}, \frac{1}{SPI_{In} + t_{SETUP}})$$

Where SPI_{in} is the MISO delay, SPI6 or SPI9 depending on CPOL and NCPHA. t_{SETUP} is the SPI master setup time. refer to the SPI master datasheet for $t_{SETUP} \cdot f_{PINMAX}$ is the maximum frequency of the SPI pins. refer to the I/O Pin Characteristics section for the maximum frequency of the pins.

9.10.4 TWIM/TWIS Timing

Figure 9-64 shows the TWI-bus timing requirements and the compliance of the device with them. Some of these requirements (t_r and t_f) are met by the device without requiring user intervention. Compliance with the other requirements (t_{HD-STA} , t_{SU-STA} , t_{SU-STO} , t_{HD-DAT} , $t_{SU-DAT-TWI}$, $t_{LOW-TWI}$, t_{HIGH} , and f_{TWCK}) requires user intervention through appropriate programming of the relevant TWIM and TWIS user interface registers. refer to the TWIM and TWIS sections for more information.

Table 9-64. TWI-Bus Timing Requirements

Symbol	Parameter	Mode	Minimum		Maximum		Unit
			Requirement	Device	Requirement	Device	
t_r	TWCK and TWD rise time	Standard ⁽¹⁾	-		1000		ns
		Fast ⁽¹⁾	$20 + 0.1C_b$		300		
t_f	TWCK and TWD fall time	Standard	-		300		ns
		Fast	$20 + 0.1C_b$		300		
t_{HD-STA}	(Repeated) START hold time	Standard	4	t_{clkpb}	-		μs
		Fast	0.6				
t_{SU-STA}	(Repeated) START set-up time	Standard	4.7	t_{clkpb}	-		μs
		Fast	0.6				
t_{SU-STO}	STOP set-up time	Standard	4.0	$4t_{clkpb}$	-		μs
		Fast	0.6				
t_{HD-DAT}	Data hold time	Standard	0.3 ⁽²⁾	$2t_{clkpb}$	3.45 ⁰	$15t_{prescaled} + t_{clkpb}$	μs
		Fast			0.9 ⁰		
$t_{SU-DAT-TWI}$	Data set-up time	Standard	250	$2t_{clkpb}$	-		ns
		Fast	100				
t_{SU-DAT}		-	-	t_{clkpb}	-		-
$t_{LOW-TWI}$	TWCK LOW period	Standard	4.7	$4t_{clkpb}$	-		μs
		Fast	1.3				
t_{LOW}		-	-	t_{clkpb}	-		-
t_{HIGH}	TWCK HIGH period	Standard	4.0	$8t_{clkpb}$	-		μs
		Fast	0.6				
f_{TWCK}	TWCK frequency	Standard	-		100	$\frac{1}{12t_{clkpb}}$	kHz
		Fast			400		

Notes: 1. Standard mode: $f_{TWCK} \leq 100$ kHz ; fast mode: $f_{TWCK} > 100$ kHz .

- A device must internally provide a hold time of at least 300 ns for TWD with reference to the falling edge of TWCK.

Notations:

C_b = total capacitance of one bus line in pF

t_{clkpb} = period of TWI peripheral bus clock

$t_{prescaled}$ = period of TWI internal prescaled clock (see chapters on TWIM and TWIS)

The maximum $t_{HD;DAT}$ has only to be met if the device does not stretch the LOW period ($t_{LOW-TWI}$) of TWCK.

9.10.5 JTAG Timing

Figure 9-17. JTAG Interface Signals

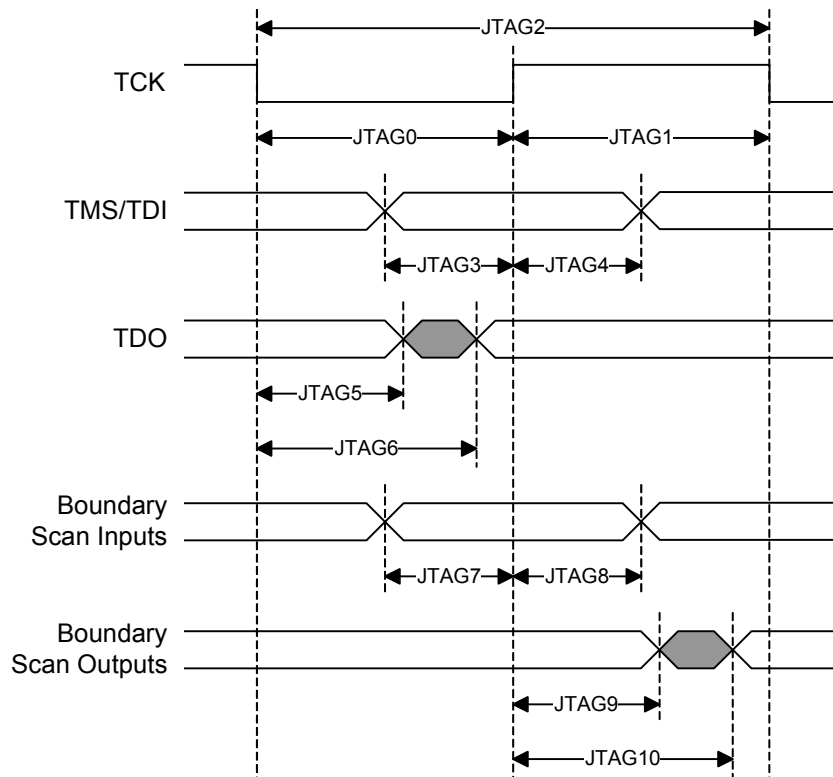

Table 9-65. JTAG Timings⁽¹⁾

Symbol	Parameter	Conditions	Min	Max	Units
JTAG0	TCK Low Half-period	V _{VDDIO} from 3.0V to 3.6V, maximum external capacitor = 40pF	21.8		ns
JTAG1	TCK High Half-period		8.6		
JTAG2	TCK Period		30.3		
JTAG3	TDI, TMS Setup before TCK High		2.0		
JTAG4	TDI, TMS Hold after TCK High		2.3		
JTAG5	TDO Hold Time		9.5		
JTAG6	TCK Low to TDO Valid			21.8	
JTAG7	Boundary Scan Inputs Setup Time		0.6		
JTAG8	Boundary Scan Inputs Hold Time		6.9		
JTAG9	Boundary Scan Outputs Hold Time		9.3		
JTAG10	TCK to Boundary Scan Outputs Valid			32.2	

Note: 1. These values are based on simulation. These values are not covered by test limits in production.

9.10.6 SWD Timing

Figure 9-18. SWD Interface Signals

Read Cycle

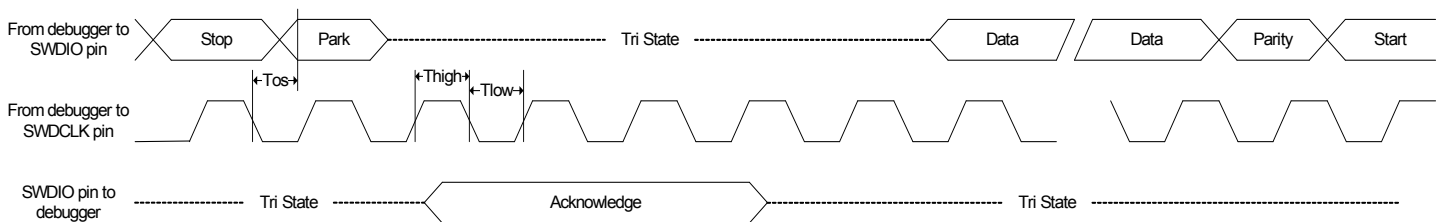

Write Cycle

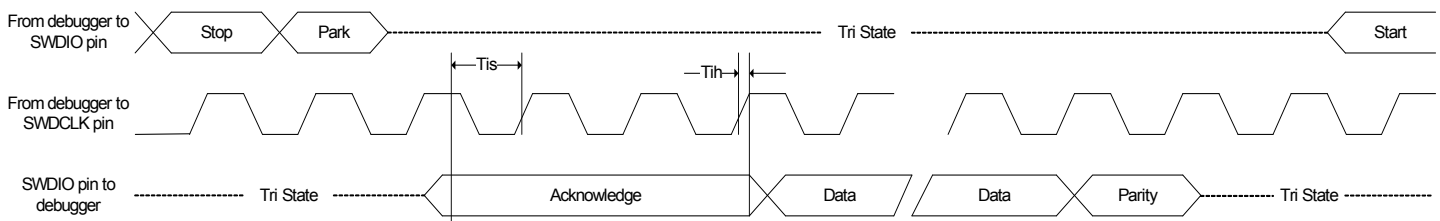

Table 9-66. SWD Timings⁽¹⁾

Symbol	Parameter	Conditions	Min	Max	Units
T _{high}	SWDCLK High period	V _{VDDIO} from 3.0V to 3.6V, maximum external capacitor = 40pF	10	500 000	ns
T _{low}	SWDCLK Low period		10	500 000	
T _{os}	SWDIO output skew to falling edge SWDCLK		-5	5	
T _{is}	Input Setup time required between SWDIO		4	-	
T _{ih}	Input Hold time required between SWDIO and rising edge SWDCLK		1	-	

Note: 1. These values are based on simulation. These values are not covered by test limits in production or characterization.

10. Mechanical Characteristics

10.1 Thermal Considerations

10.1.1 Thermal Data

Table 10-1 summarizes the thermal resistance data depending on the package.

Table 10-1. Thermal Resistance Data

Symbol	Parameter	Condition	Package	Typ	Unit
θ_{JA}	Junction-to-ambient thermal resistance	Still Air	TQFP100	48.1	°C/W
θ_{JC}	Junction-to-case thermal resistance		TQFP100	13.3	
θ_{JA}	Junction-to-ambient thermal resistance	Still Air	VFBGA100	31.1	°C/W
θ_{JC}	Junction-to-case thermal resistance		VFBGA100	6.9	
θ_{JA}	Junction-to-ambient thermal resistance	Still Air	WLCSP64	26.9	°C/W
θ_{JC}	Junction-to-case thermal resistance		WLCSP64	0.2	
θ_{JA}	Junction-to-ambient thermal resistance	Still Air	TQFP64	49.6	°C/W
θ_{JC}	Junction-to-case thermal resistance		TQFP64	13.5	
θ_{JA}	Junction-to-ambient thermal resistance	Still Air	QFN64	22.0	°C/W
θ_{JC}	Junction-to-case thermal resistance		QFN64	1.3	
θ_{JA}	Junction-to-ambient thermal resistance	Still Air	TQFP48	51.1	°C/W
θ_{JC}	Junction-to-case thermal resistance		TQFP48	13.7	
θ_{JA}	Junction-to-ambient thermal resistance	Still Air	QFN48	24.9	°C/W
θ_{JC}	Junction-to-case thermal resistance		QFN48	1.3	

10.1.2 Junction Temperature

The average chip-junction temperature, T_J , in °C can be obtained from the following:

- $T_J = T_A + (P_D \times \theta_{JA})$
- $T_J = T_A + (P_D \times (\theta_{HEATSINK} + \theta_{JC}))$

where:

- θ_{JA} = package thermal resistance, Junction-to-ambient (°C/W), provided in Table 10-1.
- θ_{JC} = package thermal resistance, Junction-to-case thermal resistance (°C/W), provided in Table 10-1.
- $\theta_{HEAT\ SINK}$ = cooling device thermal resistance (°C/W), provided in the device datasheet.
- P_D = device power consumption (W) estimated from data provided in Section 9.5 on page 102.
- T_A = ambient temperature (°C).

From the first equation, the user can derive the estimated lifetime of the chip and decide if a cooling device is necessary or not. If a cooling device is to be fitted on the chip, the second equation should be used to compute the resulting average chip-junction temperature T_J in °C.

10.2 Package Drawings

Figure 10-1. VFBGA-100 package drawing

DRAWINGS NOT SCALED

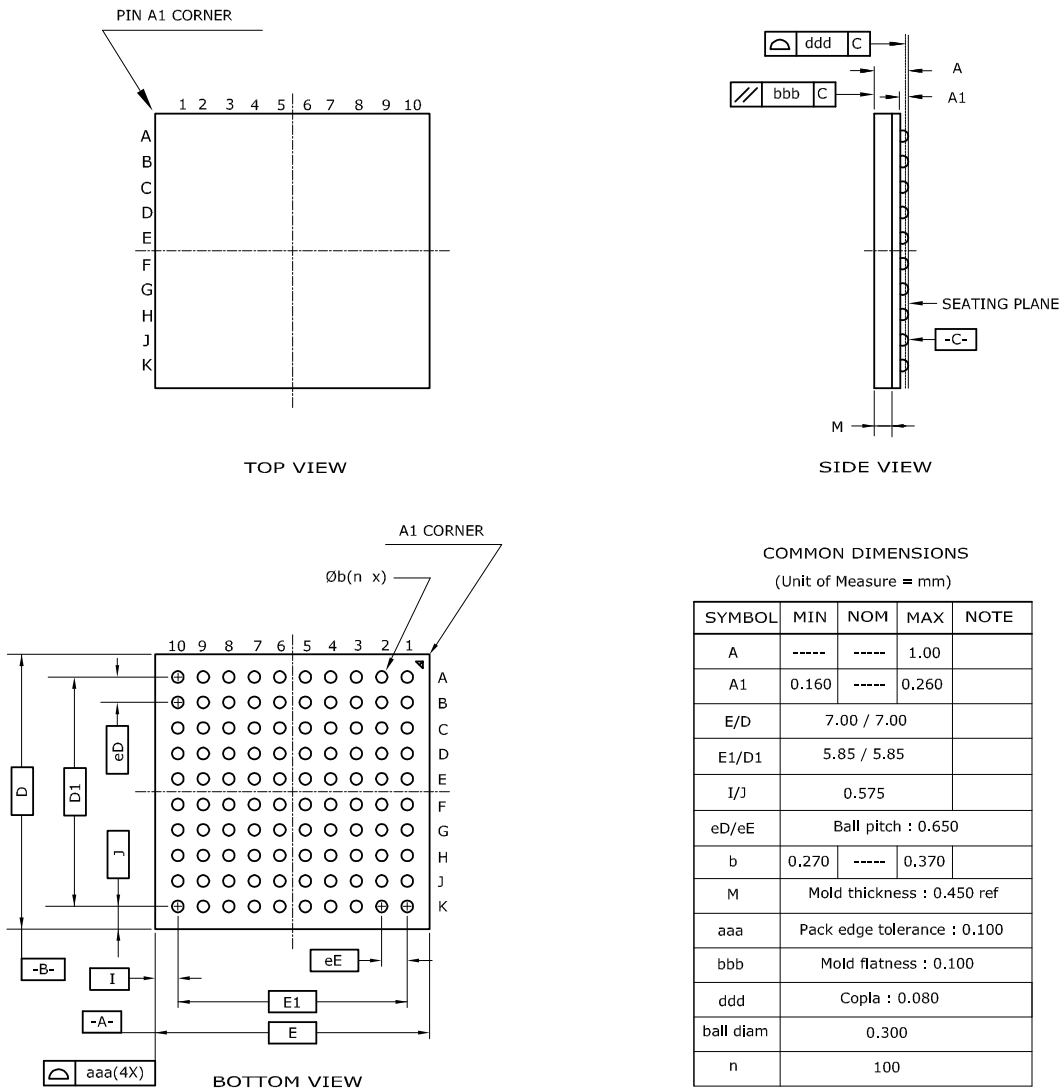

- Notes :
1. No JEDEC Drawing Reference.
 2. Array as seen from the bottom of the package.
 3. Dimension A includes stand-off height A1, package body thickness, and lid height, but does not include attached features.
 4. Dimension b is measured at the maximum ball diameter, parallel to primary datum C.

Table 10-2. Device and Package Maximum Weight

120	mg
-----	----

Table 10-3. Package Characteristics

Moisture Sensitivity Level	MSL3
----------------------------	------

Table 10-4. Package Reference

JEDEC Drawing Reference	N/A
JESD97 Classification	E1

Figure 10-2. TQFP-100 Package Drawing

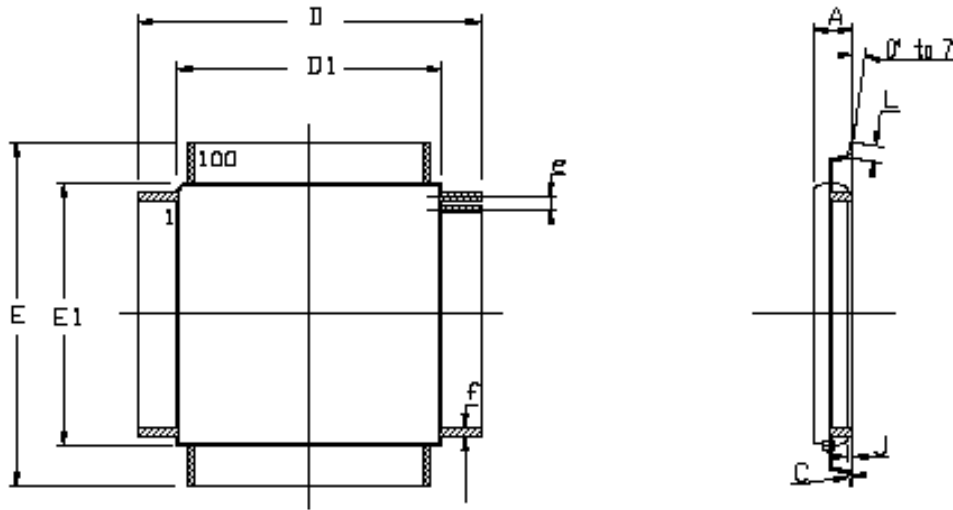

COMMON DIMENSIONS IN MM

SYMBOL	MIN	MAX	NOTES
A	----	1.20	
A1	0.95	1.05	
C	0.09	0.20	
D	16.00 BSC		
D1	14.00 BSC		
E	16.00 BSC		
E1	14.00 BSC		
J	0.05	0.15	
L	0.45	0.75	
e	0.50 BSC		
f	0.17	0.27	

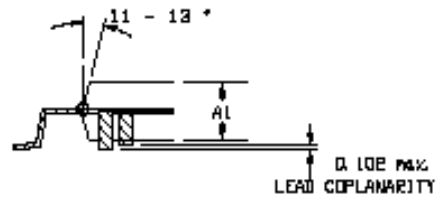

Table 10-5. Device and Package Maximum Weight

500	mg
-----	----

Table 10-6. Package Characteristics

Moisture Sensitivity Level	MSL3
----------------------------	------

Table 10-7. Package Reference

JEDEC Drawing Reference	MS-026
JESD97 Classification	E3

Figure 10-3. WLCSP64 SAM4LC4/2 Package Drawing

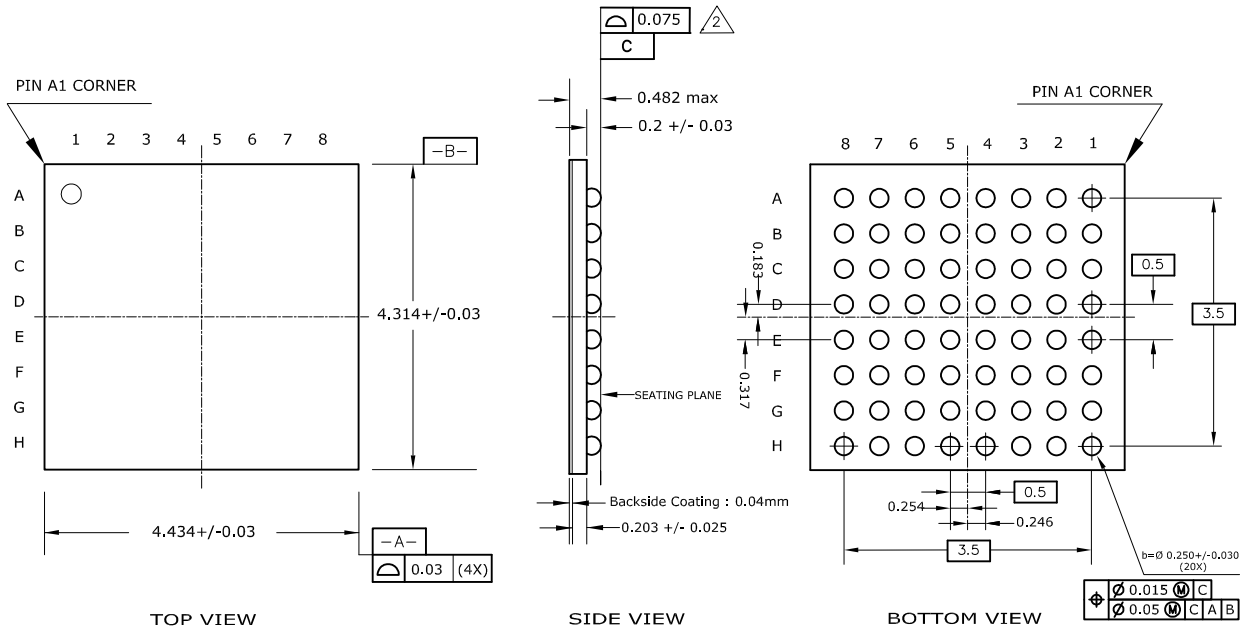

COMMON DIMENSIONS
(Unit of Measure = mm)

BALL	SIGNAL	X COORD	Y COORD
A1	PB04	1.746	1.683
A2	GNDANA	1.246	1.683
A3	ADVREFP	0.746	1.683
A4	VDDANA	0.246	1.683
A5	PA09	-0.254	1.683
A6	CAPL	-0.754	1.683
A7	CAPH	-1.254	1.683
A8	PA12	-1.754	1.683
B1	PB03	1.746	1.183
B2	XIN32	1.246	1.183
B3	XOUT32	0.746	1.183
B4	PA08	0.246	1.183
B5	PB06	-0.254	1.183
B6	PA10	-0.754	1.183
B7	PA11	-1.254	1.183
B8	VLCD	-1.754	1.183
C1	VDDIN	1.746	0.683
C2	PB01	1.246	0.683
C3	PA05	0.746	0.683
C4	PA06	0.246	0.683
C5	PA07	-0.254	0.683
C6	PB07	-0.754	0.683

BALL	SIGNAL	X COORD	Y COORD
C7	PA13	-1.254	0.683
C8	BIAS1	-1.754	0.683
D1	VDDOUT	1.746	0.183
D2	PB00	1.246	0.183
D3	PA04	0.746	0.183
D4	PB05	0.246	0.183
D5	PB12	-0.254	0.183
D6	PB08	-0.754	0.183
D7	PA14	-1.254	0.183
D8	BIAS2	-1.754	0.183
E1	GNDIN	1.746	-0.317
E2	PA03	1.246	-0.317
E3	PB02	0.746	-0.317
E4	RESET_N	0.246	-0.317
E5	PB13	-0.254	-0.317
E6	PB09	-0.754	-0.317
E7	PA15	-1.254	-0.317
E8	GNDIO0	-1.754	-0.317
F1	VDDCORE	1.746	-0.817
F2	TCK	1.246	-0.817
F3	PA02	0.746	-0.817
F4	PB14	0.246	-0.817

BALL	SIGNAL	X COORD	Y COORD
F5	PA22	-0.254	-0.817
F6	PB10	-0.754	-0.817
F7	PA16	-1.254	-0.817
F8	VLCDIN	-1.754	-0.817
G1	GNDIO1	1.746	-1.317
G2	PA26	1.246	-1.317
G3	PA24	0.746	-1.317
G4	PA00	0.246	-1.317
G5	PA01	-0.254	-1.317
G6	PA19	-0.754	-1.317
G7	PA18	-1.254	-1.317
G8	PA17	-1.754	-1.317
H1	VDDIO1	1.746	-1.817
H2	PA25	1.246	-1.817
H3	PA23	0.746	-1.817
H4	PB15	0.246	-1.817
H5	PA21	-0.254	-1.817
H6	VDDIO0	-0.754	-1.817
H7	PA20	-1.254	-1.817
H8	PB11	-1.754	-1.817

Notes : 1. Dimension "b" is measured at the maximum ball diameter in a plane to the seating plane.

2. Applied to whole wafer.

Table 10-8. Device and Package Maximum Weight

14.8	mg
------	----

Table 10-9. Package Characteristics

Moisture Sensitivity Level	MSL3
----------------------------	------

Table 10-10. Package Reference

JEDEC Drawing Reference	MS-026
JESD97 Classification	E1

Figure 10-4. WLCSP64 SAM4LS4/2 Package Drawing

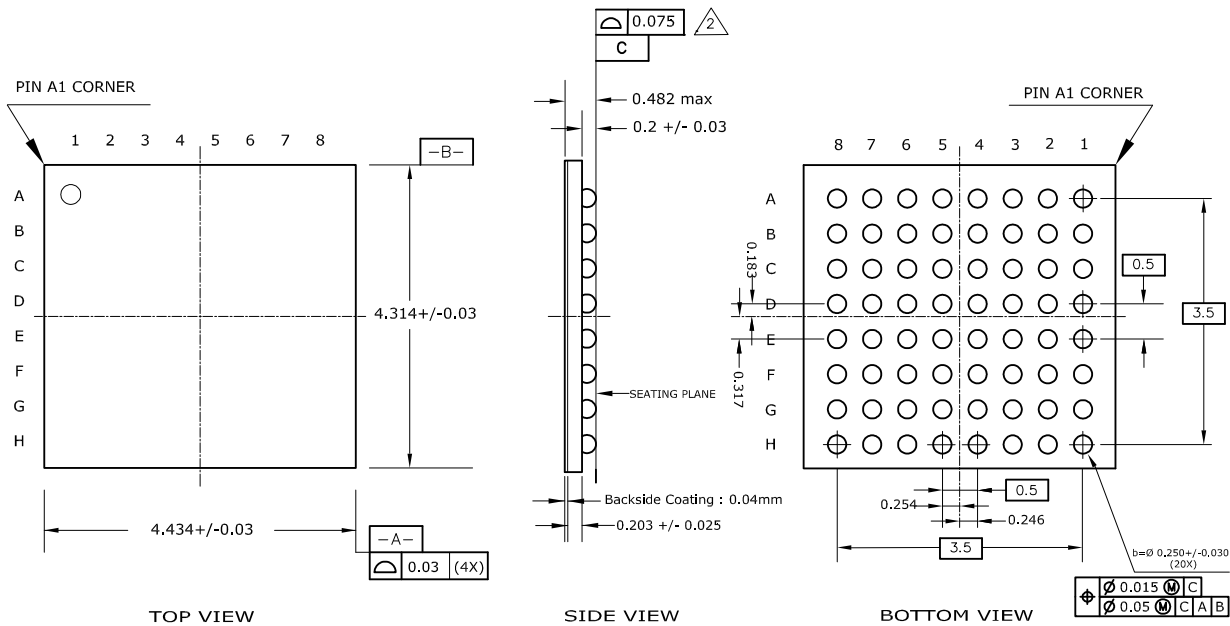

COMMON DIMENSIONS
(Unit of Measure = mm)

BALL	SIGNAL	X COORD	Y COORD
A1	PB04	1.746	1.683
A2	GNDANA	1.246	1.683
A3	ADVREFP	0.746	1.683
A4	VDDANA	0.246	1.683
A5	PA09	-0.254	1.683
A6	PA28	-0.754	1.683
A7	PA27	-1.254	1.683
A8	PA12	-1.754	1.683
B1	PB03	1.746	1.183
B2	XIN32	1.246	1.183
B3	XOUT32	0.746	1.183
B4	PA08	0.246	1.183
B5	PB06	-0.254	1.183
B6	PA10	-0.754	1.183
B7	PA11	-1.254	1.183
B8	PA29	-1.754	1.183
C1	VDDIN	1.746	0.683
C2	PB01	1.246	0.683
C3	PA05	0.746	0.683
C4	PA06	0.246	0.683
C5	PA07	-0.254	0.683
C6	PB07	-0.754	0.683

BALL	SIGNAL	X COORD	Y COORD
C7	PA13	-1.254	0.683
C8	GNDIO0	-1.754	0.683
D1	VDDOUT	1.746	0.183
D2	PB00	1.246	0.183
D3	PA04	0.746	0.183
D4	PB05	0.246	0.183
D5	PB12	-0.254	0.183
D6	PB08	-0.754	0.183
D7	PA14	-1.254	0.183
D8	VLCDIN	-1.754	0.183
E1	GNDIN	1.746	-0.317
E2	PA03	1.246	-0.317
E3	PB02	0.746	-0.317
E4	RESET_N	0.246	-0.317
E5	PB13	-0.254	-0.317
E6	PB09	-0.754	-0.317
E7	PA15	-1.254	-0.317
E8	PA30	-1.754	-0.317
F1	VDDCORE	1.746	-0.817
F2	TCK	1.246	-0.817
F3	PA02	0.746	-0.817
F4	PB14	0.246	-0.817

BALL	SIGNAL	X COORD	Y COORD
F5	PA22	-0.254	-0.817
F6	PB10	-0.754	-0.817
F7	PA16	-1.254	-0.817
F8	PA31	-1.754	-0.817
G1	GNDIO1	1.746	-1.317
G2	PA26	1.246	-1.317
G3	PA24	0.746	-1.317
G4	PA00	0.246	-1.317
G5	PA01	-0.254	-1.317
G6	PA19	-0.754	-1.317
G7	PA18	-1.254	-1.317
G8	PA17	-1.754	-1.317
H1	VDDIO1	1.746	-1.817
H2	PA25	1.246	-1.817
H3	PA23	0.746	-1.817
H4	PB15	0.246	-1.817
H5	PA21	-0.254	-1.817
H6	VDDIO0	-0.754	-1.817
H7	PA20	-1.254	-1.817
H8	PB11	-1.754	-1.817

- Notes :
1. Dimension "b" is measured at the maximum ball diameter in a plane to the seating plane.
 2. Applied to whole wafer.

Table 10-11. Device and Package Maximum Weight

14.8	mg
------	----

Table 10-12. Package Characteristics

Moisture Sensitivity Level	MSL3
----------------------------	------

Table 10-13. Package Reference

JEDEC Drawing Reference	MS-026
JESD97 Classification	E1

Figure 10-5. TQFP-64 Package Drawing

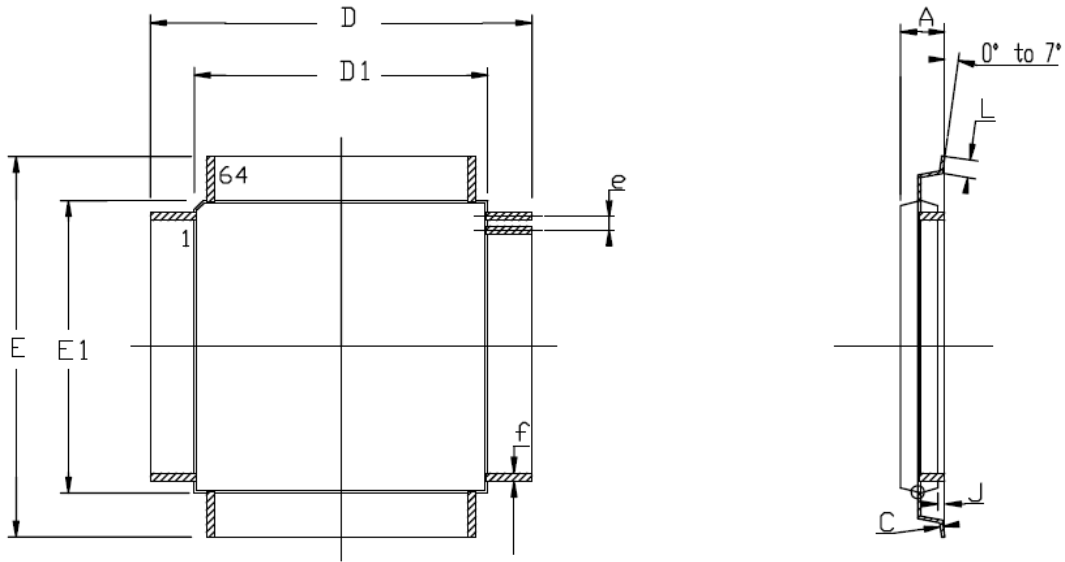

COMMON DIMENSIONS IN MM

SYMBOL	Min	Max	NOTES
A	----	1.20	
A1	0.95	1.05	
C	0.09	0.20	
D	12.00 BSC		
D1	10.00 BSC		
E	12.00 BSC		
E1	10.00 BSC		
J	0.05	0.15	
L	0.45	0.75	
e	0.50 BSC		
f	0.17	0.27	

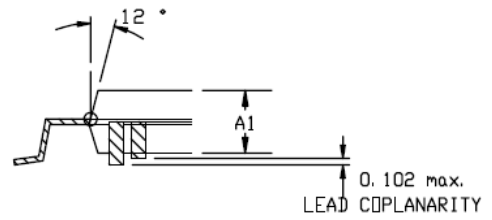

Table 10-14. Device and Package Maximum Weight

300	mg
-----	----

Table 10-15. Package Characteristics

Moisture Sensitivity Level	MSL3
----------------------------	------

Table 10-16. Package Reference

JEDEC Drawing Reference	MS-026
JESD97 Classification	E3

Figure 10-6. QFN-64 Package Drawing

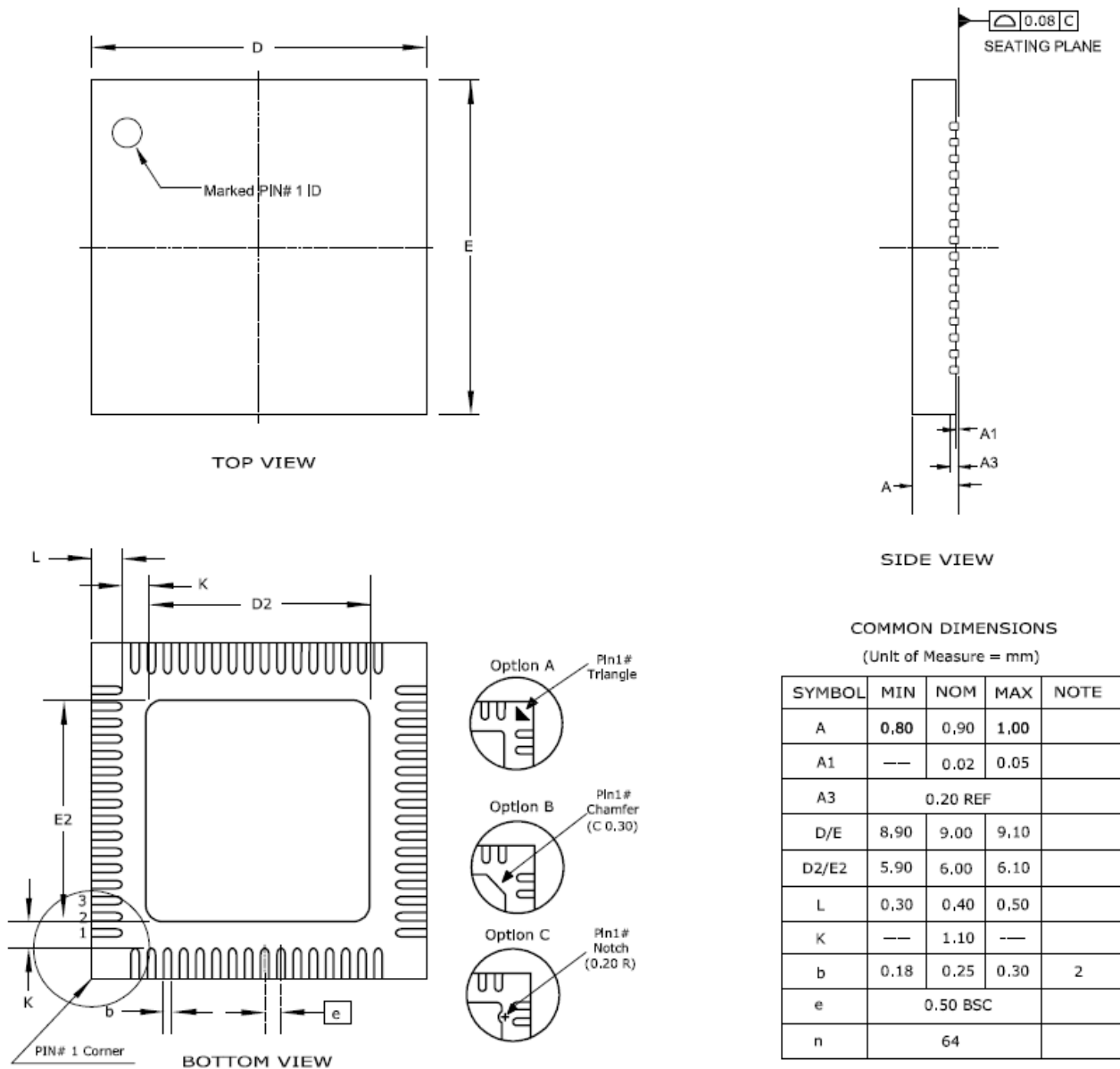

Note: The exposed pad is not connected to anything internally, but should be soldered to ground to increase board level reliability.

Table 10-17. Device and Package Maximum Weight

200	mg
-----	----

Table 10-18. Package Characteristics

Moisture Sensitivity Level	MSL3
----------------------------	------

Table 10-19. Package Reference

JEDEC Drawing Reference	MO-220
JESD97 Classification	E3

Figure 10-7. TQFP-48 (ATSAM4LC4/2 and ATSAM4LS4/2 Only) Package Drawing

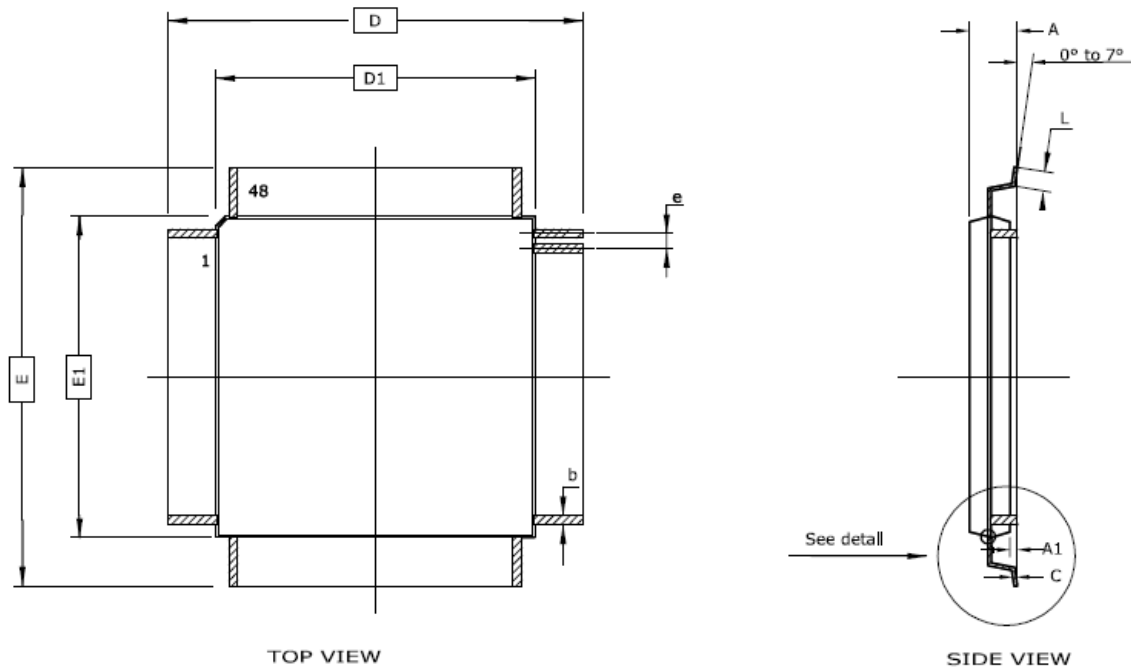

COMMON DIMENSIONS
(Unit of Measure = mm)

SYMBOL	MIN	NOM	MAX	NOTE
A	---	---	1,20	
A1	0,05	---	0,15	
A2	0,95	---	1,05	
C	0,09	---	0,20	
D/E	9,00 BSC			
D1/E1	7,00 BSC			
L	0,45	---	0,75	
b	0,17	---	0,27	
e	0,50 BSC			

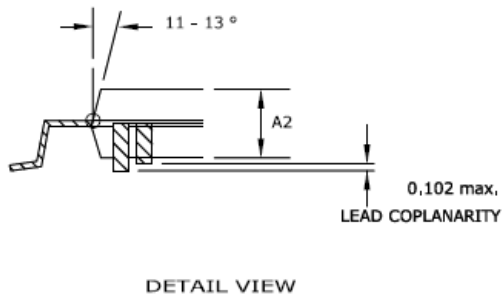

Table 10-20. Device and Package Maximum Weight

140	mg
-----	----

Table 10-21. Package Characteristics

Moisture Sensitivity Level	MSL3
----------------------------	------

Table 10-22. Package Reference

JEDEC Drawing Reference	MS-026
JESD97 Classification	E3

Figure 10-8. QFN-48 Package Drawing for ATSAM4LC4/2 and ATSAM4LS4/2

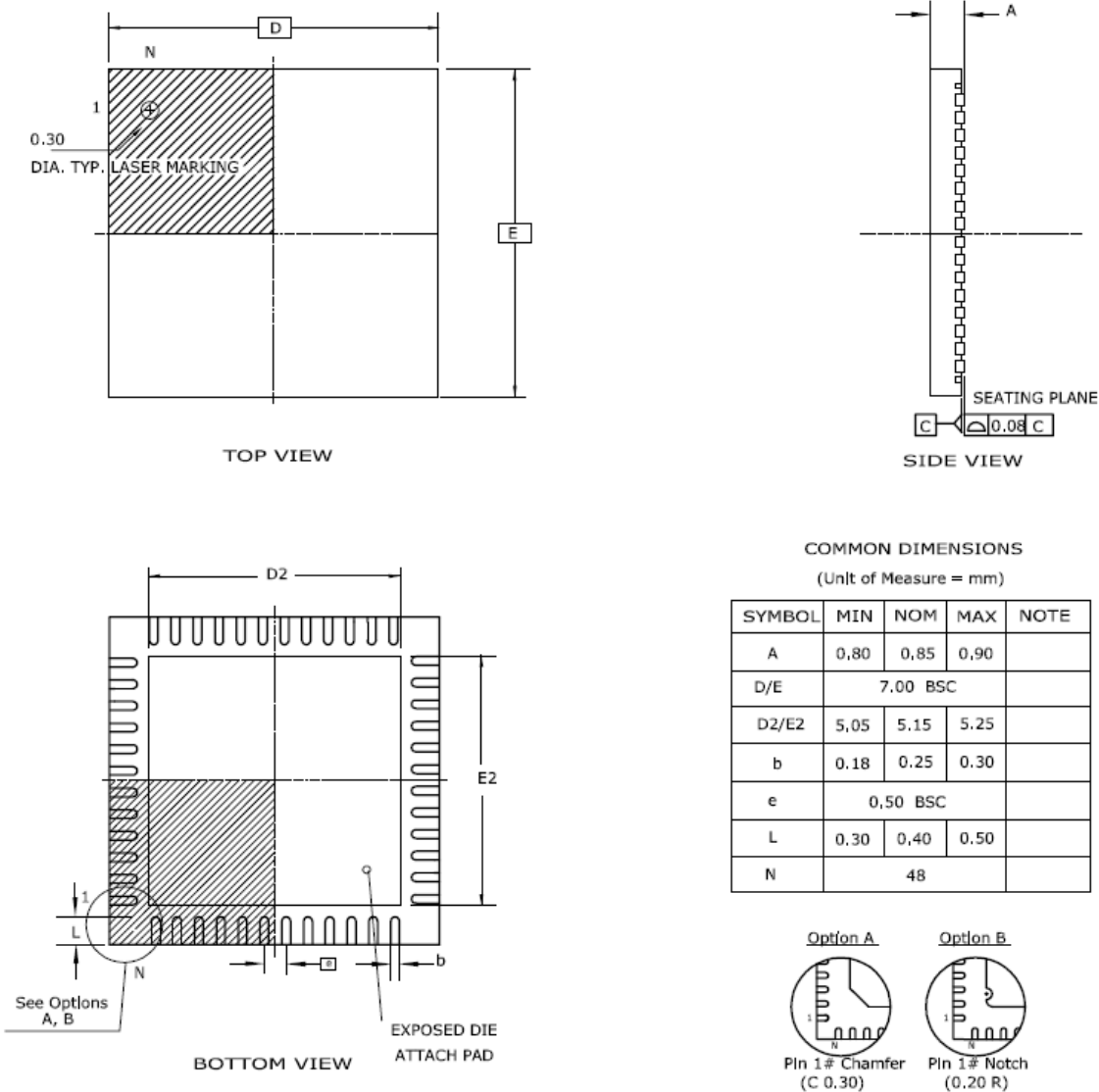

Note: The exposed pad is not connected to anything internally, but should be soldered to ground to increase board level reliability.

Table 10-23. Device and Package Maximum Weight

140	mg
-----	----

Table 10-24. Package Characteristics

Moisture Sensitivity Level	MSL3
----------------------------	------

Table 10-25. Package Reference

JEDEC Drawing Reference	MO-220
JESD97 Classification	E3

Figure 10-9. QFN-48 Package Drawing for ATSAM4LC8 and ATSAM4LS8

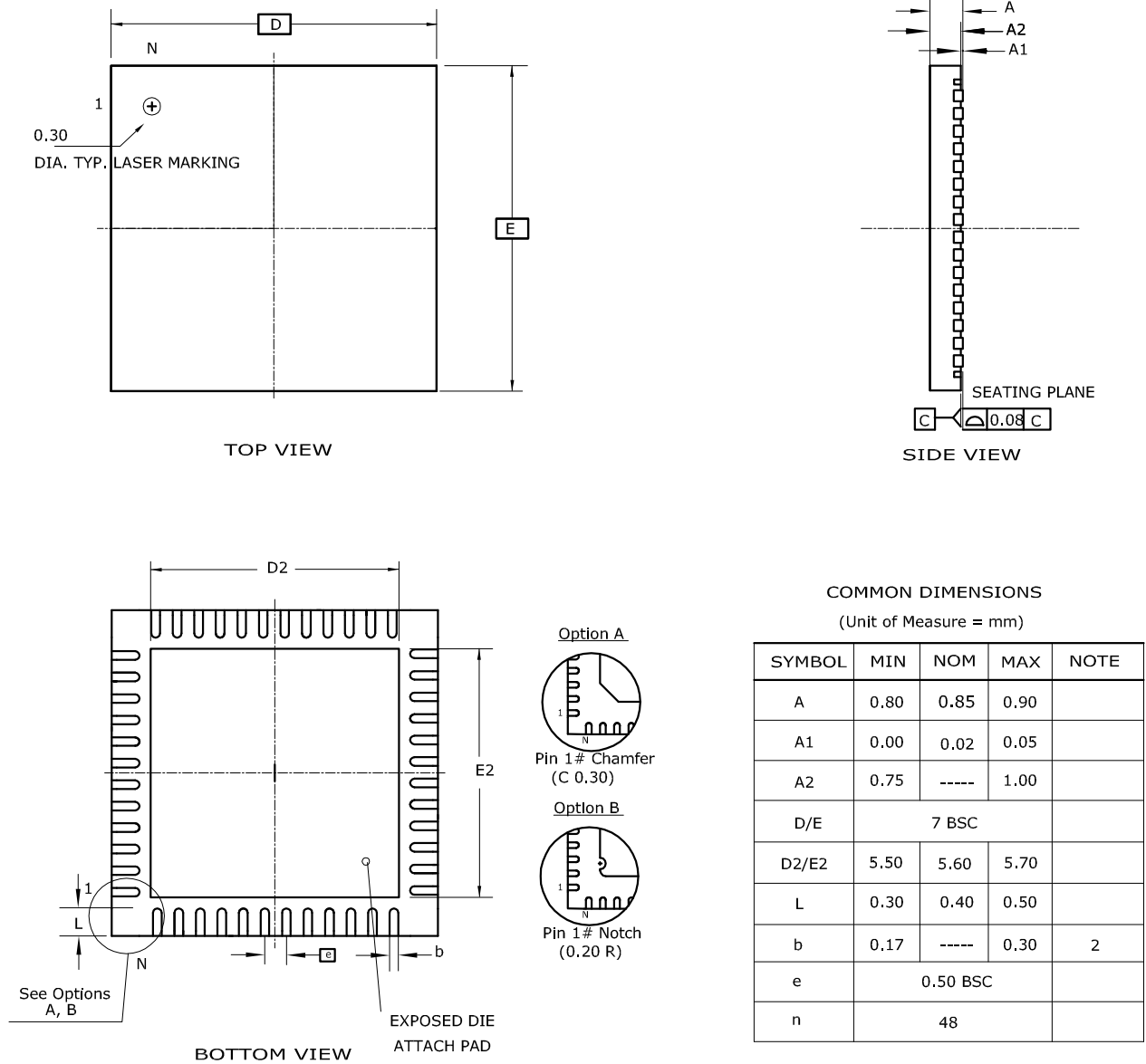

Note: The exposed pad is not connected to anything internally, but should be soldered to ground to increase board level reliability.

Table 10-26. Device and Package Maximum Weight

140	mg
-----	----

Table 10-27. Package Characteristics

Moisture Sensitivity Level	MSL3
----------------------------	------

Table 10-28. Package Reference

JEDEC Drawing Reference	MO-220
JESD97 Classification	E3

10.3 Soldering Profile

Table 10-29 gives the recommended soldering profile from J-STD-20.

Table 10-29. Soldering Profile

Profile Feature	Green Package
Average Ramp-up Rate (217°C to Peak)	3°C/s max
Preheat Temperature 175°C ±25°C	150-200°C
Time Maintained Above 217°C	60-150 s
Time within 5-C of Actual Peak Temperature	30 s
Peak Temperature Range	260°C
Ramp-down Rate	6°C/s max
Time 25-C to Peak Temperature	8 minutes max

A maximum of three reflow passes is allowed per component.

11. Ordering Information

Table 11-1. ATSAM4LC8 Sub Serie Ordering Information

Ordering Code	Flash (Kbytes)	RAM (Kbytes)	Package	Conditioning	Package Type	Temperature Operating Range
ATSAM4LC8CA-AU	512	64	TQFP100	Tray	Green	Industrial -40°C to 85°C
ATSAM4LC8CA-AUR				Reel		
ATSAM4LC8CA-CFU			VFBGA100	Tray		
ATSAM4LC8CA-CFUR				Reel		
ATSAM4LC8BA-AU			TQFP64	Tray		
ATSAM4LC8BA-AUR				Reel		
ATSAM4LC8BA-MU			QFN64	Tray		
ATSAM4LC8BA-MUR				Reel		
ATSAM4LC8AA-MU			QFN48	Tray		
ATSAM4LC8AA-MUR				Reel		

Table 11-2. ATSAM4LC4 Sub Serie Ordering Information

Ordering Code	Flash (Kbytes)	RAM (Kbytes)	Package	Conditioning	Package Type	Temperature Operating Range	
ATSAM4LC4CA-AU-ES	256	32	TQFP100	ES	Green	N/A	
ATSAM4LC4CA-AU				Tray		Industrial -40°C to 85°C	
ATSAM4LC4CA-AUR				Reel			
ATSAM4LC4CA-CFU			VFBGA100	Tray			
ATSAM4LC4CA-CFUR				Reel		Industrial -40°C to 85°C	
ATSAM4LC4BA-AU-ES			TQFP64	ES		N/A	
ATSAM4LC4BA-AU				Tray		Industrial -40°C to 85°C	
ATSAM4LC4BA-AUR				Reel			
ATSAM4LC4BA-MU-ES			QFN64	ES		N/A	
ATSAM4LC4BA-MU				Tray		Industrial -40°C to 85°C	
ATSAM4LC4BA-MUR				Reel			
ATSAM4LC4BA-UUR			WLCSP64	Reel		Industrial -40°C to 85°C	
ATSAM4LC4AA-AU-ES			TQFP48	ES		N/A	
ATSAM4LC4AA-AU				Tray		Industrial -40°C to 85°C	
ATSAM4LC4AA-AUR				Reel			
ATSAM4LC4AA-MU-ES				QFN48		ES	N/A
ATSAM4LC4AA-MU						Tray	Industrial -40°C to 85°C
ATSAM4LC4AA-MUR						Reel	

Table 11-3. ATSAM4LC2 Sub Serie Ordering Information

Ordering Code	Flash (Kbytes)	RAM (Kbytes)	Package	Conditioning	Package Type	Temperature Operating Range
ATSAM4LC2CA-AU	128	32	TQFP100	Tray	Green	Industrial -40°C to 85°C
ATSAM4LC2CA-AUR				Reel		
ATSAM4LC2CA-CFU			VFBGA100	Tray		
ATSAM4LC2CA-CFUR				Reel		
ATSAM4LC2BA-AU			TQFP64	Tray		
ATSAM4LC2BA-AUR				Reel		
ATSAM4LC2BA-MU			QFN64	Tray		
ATSAM4LC2BA-MUR				Reel		
ATSAM4LC2BA-UUR			WLCSP64	Reel		
ATSAM4LC2AA-AU			TQFP48	Tray		
ATSAM4LC2AA-AUR				Reel		
ATSAM4LC2AA-MU			QFN48	Tray		
ATSAM4LC2AA-MUR				Reel		

Table 11-4. ATSAM4LS8 Sub Serie Ordering Information

Ordering Code	Flash (Kbytes)	RAM (Kbytes)	Package	Conditioning	Package Type	Temperature Operating Range
ATSAM4LS8CA-AU	512	64	TQFP100	Tray	Green	Industrial -40°C to 85°C
ATSAM4LS8CA-AUR				Reel		
ATSAM4LS8CA-CFU			VFBGA100	Tray		
ATSAM4LS8CA-CFUR				Reel		
ATSAM4LS8BA-AU			TQFP64	Tray		
ATSAM4LS8BA-AUR				Reel		
ATSAM4LS8BA-MU			QFN64	Tray		
ATSAM4LS8BA-MUR				Reel		
ATSAM4LS8AA-MU			QFN48	Tray		
ATSAM4LS8AA-MUR				Reel		

Table 11-5. ATSAM4LS4 Sub Serie Ordering Information

Ordering Code	Flash (Kbytes)	RAM (Kbytes)	Package	Conditioning	Package Type	Temperature Operating Range
ATSAM4LS4CA-AU-ES	256	32	TQFP100	ES	Green	N/A
ATSAM4LS4CA-AU				Tray		Industrial -40°C to 85°C
ATSAM4LS4CA-AUR				Reel		
ATSAM4LS4CA-CFU			VFBGA100	Tray		Industrial -40°C to 85°C
ATSAM4LS4CA-CFUR				Reel		
ATSAM4LS4BA-AU-ES			TQFP64	ES		N/A
ATSAM4LS4BA-AU				Tray		Industrial -40°C to 85°C
ATSAM4LS4BA-AUR				Reel		
ATSAM4LS4BA-MU-ES			QFN64	ES		N/A
ATSAM4LS4BA-MU				Tray		Industrial -40°C to 85°C
ATSAM4LS4BA-MUR				Reel		
ATSAM4LS4BA-UUR			WLCSP64	Reel		Industrial -40°C to 85°C
ATSAM4LS4AA-AU-ES			TQFP48	ES		N/A
ATSAM4LS4AA-AU				Tray		Industrial -40°C to 85°C
ATSAM4LS4AA-AUR				Reel		
ATSAM4LS4AA-MU-ES			QFN48	ES		N/A
ATSAM4LS4AA-MU				Tray		Industrial -40°C to 85°C
ATSAM4LS4AA-MUR				Reel		

Table 11-6. ATSAM4LS2 Sub Serie Ordering Information

Ordering Code	Flash (Kbytes)	RAM (Kbytes)	Package	Conditioning	Package Type	Temperature Operating Range
ATSAM4LS2CA-AU	128	32	TQFP100	Tray	Green	Industrial -40°C to 85°C
ATSAM4LS2CA-AUR				Reel		
ATSAM4LS2CA-CFU			VFBGA100	Tray		
ATSAM4LS2CA-CFUR				Reel		
ATSAM4LS2BA-AU			TQFP64	Tray		
ATSAM4LS2BA-AUR				Reel		
ATSAM4LS2BA-MU			QFN64	Tray		
ATSAM4LS2BA-MUR				Reel		
ATSAM4LS2BA-UUR			WLCSP64	Reel		
ATSAM4LS2AA-AU			TQFP48	Tray		
ATSAM4LS2AA-AUR				Reel		
ATSAM4LS2AA-MU			QFN48	Tray		
ATSAM4LS2AA-MUR				Reel		

12. Errata

12.1 ATSAM4L4 /2 Rev. B & ATSAM4L8 Rev. A

12.1.1 General

PS2 mode is not supported by Engineering Samples

PS2 mode support is supported only by parts with calibration version higher than 0.

Fix/Workaround

The calibration version can be checked by reading a 32-bit word at address 0x0080020C. The calibration version bitfield is 4-bit wide and located from bit 4 to bit 7 in this word. Any value higher than 0 ensures that the part supports the PS2 mode

12.1.2 SCIF

PLLCOUNT value larger than zero can cause PLEN glitch

Initializing the PLLCOUNT with a value greater than zero creates a glitch on the PLEN signal during asynchronous wake up.

Fix/Workaround

The lock-masking mechanism for the PLL should not be used. The PLLCOUNT field of the PLL Control Register should always be written to zero.

12.1.3 WDT

WDT Control Register does not have synchronization feedback

When writing to the Timeout Prescale Select (PSEL), Time Ban Prescale Select (TBAN), Enable (EN), or WDT Mode (MODE) fields of the WDT Control Register (CTRL), a synchronizer is started to propagate the values to the WDT clock domain. This synchronization takes a finite amount of time, but only the status of the synchronization of the EN bit is reflected back to the user. Writing to the synchronized fields during synchronization can lead to undefined behavior.

Fix/Workaround

- When writing to the affected fields, the user must ensure a wait corresponding to 2 clock cycles of both the WDT peripheral bus clock and the selected WDT clock source.
- When doing writes that changes the EN bit, the EN bit can be read back until it reflects the written value.

12.1.4 SPI

SPI data transfer hangs with CSR0.CSAAT==1 and MR.MODFDIS==0

When CSR0.CSAAT==1 and mode fault detection is enabled (MR.MODFDIS==0), the SPI module will not start a data transfer.

Fix/Workaround

Disable mode fault detection by writing a one to MR.MODFDIS.

SPI disable does not work in SLAVE mode

SPI disable does not work in SLAVE mode.

Fix/Workaround

Read the last received data, then perform a software reset by writing a one to the Software Reset bit in the Control Register (CR.SWRST).

Disabling SPI has no effect on the SR.TDRE bit

Disabling SPI has no effect on the SR.TDRE bit whereas the write data command is filtered when SPI is disabled. Writing to TDR when SPI is disabled will not clear SR.TDRE. If SPI is disabled during a PDCA transfer, the PDCA will continue to write data to TDR until its buffer is empty, and this data will be lost.

Fix/Workaround

Disable the PDCA, add two NOPs, and disable the SPI. To continue the transfer, enable the SPI and PDCA.

SPI bad serial clock generation on 2nd chip_select when SCBR=1, CPOL=1, and NCPHA=0

When multiple chip selects (CS) are in use, if one of the baudrates equal 1 while one (CSRn.SCBR=1) of the others do not equal 1, and CSRn.CPOL=1 and CSRn.NCPHA=0, then an additional pulse will be generated on SCK.

Fix/Workaround

When multiple CS are in use, if one of the baudrates equals 1, the others must also equal 1 if CSRn.CPOL=1 and CSRn.NCPHA=0.

12.1.5 TC

Channel chaining skips first pulse for upper channel

When chaining two channels using the Block Mode Register, the first pulse of the clock between the channels is skipped.

Fix/Workaround

Configure the lower channel with RA = 0x1 and RC = 0x2 to produce a dummy clock cycle for the upper channel. After the dummy cycle has been generated, indicated by the SR.CPCS bit, reconfigure the RA and RC registers for the lower channel with the real values.

12.1.6 USBC

In USB host mode, entering suspend mode for low speed device can fail when the USB freeze (USBCON.FRZCLK=1) is done just after UHCON.SOFE=0.

Fix/Workaround

When entering suspend mode (UHCON.SOFE is cleared), check that USBFSM.DRDSTATE is not equal to three before freezing the clock (USBCON.FRZCLK=1).

In USB host mode, the asynchronous attach detection (UDINT.HWUPI) can fail when the USB clock freeze (USBCON.FRZCLK=1) is done just after setting the USB-STA.VBUSRQ bit.

Fix/Workaround

After setting USBSTA.VBUSRQ bit, wait until the USBFSM register value is 'A_WAIT_BCON' before setting the USBCON.FRZCLK bit.

12.1.7 FLASHCALW

Corrupted data in flash may happen after flash page write operations.

After a flash page write operation, reading (data read or code fetch) in flash may fail. This may lead to an exception or to others errors derived from this corrupted read access.

Fix/Workaround

Before any flash page write operation, each 64-bit doublewords write in the page buffer must be preceded by a 64-bit doublewords write in the page buffer with 0xFFFFFFFF_FFFFFFFF content at any address in the page. Note that special care is required when loading page buffer, refer to [Section 2.5.9 "Page Buffer Operations" on page 11](#).

13. Datasheet Revision History

Note that the referring page numbers in this section are referred to this document. The referring revision in this section are referring to the document revision.

13.1 Rev. A – 09/12

1. Initial revision.

13.2 Rev. B – 10/12

1. Fixed ordering code
2. Changed BOD18CTRL and BOD33CTRL ACTION field from “Reserved” to ‘No action”

13.3 Rev. C – 02/13

1. Fixed ball pitch for VFBGA100 package
2. Added VFBGA100 and WLCSP64 pinouts
3. Added Power Scaling Mode 2 for high frequency support
4. Minor update on several modules chapters
5. Major update on Electrical characteristics
6. Updated errata
7. Fixed GPIO multiplexing pin numbers

13.4 Rev. D – 03/13

1. Removed WLCSP package information
2. Added errata text for detecting whether a part supports PS2 mode or not
3. Removed temperature sensor feature (not supported by production flow)
4. Fixed MUX selection on Positive ADC input channel table
5. Added information about TWI instances capabilities
6. Added some details on errata [Corrupted data in flash may happen after flash page write operations.168](#)

13.5 Rev. E – 07/13

1. Added ATSAM4L8 derivatives and WLCSP packages for ATSAM4L4/2
2. Added operating conditions details in Electrical Characteristics Chapter
3. Fixed “Supply Rise Rates and Order”
4. Added number of USART available in sub-series
5. Fixed IO line considerations for USB pins
6. Removed useless information about CPU local bus which is not implemented
7. Removed useless information about Modem support which is not implemented
8. Added information about unsupported features in Power Scaling mode 1
9. Fixed SPI timings

Table of Contents

Summary..... 1

Features 1

1 Description 3

2 Overview 5

 2.1 Block Diagram5

 2.2 Configuration Summary6

3 Package and Pinout 8

 3.1 Package8

 3.2 Peripheral Multiplexing on I/O lines 18

 3.3 Signals Description30

 3.4 I/O Line Considerations33

4 Cortex-M4 processor and core peripherals 35

 4.1 Cortex-M435

 4.2 System level interface36

 4.3 Integrated configurable debug36

 4.4 Cortex-M4 processor features and benefits summary37

 4.5 Cortex-M4 core peripherals37

 4.6 Cortex-M4 implementations options38

 4.7 Cortex-M4 Interrupts map38

 4.8 Peripheral Debug41

5 Memories 42

 5.1 Product Mapping42

 5.2 Embedded Memories43

 5.3 Physical Memory Map43

6 Power and Startup Considerations 45

 6.1 Power Domain Overview45

 6.2 Power Supplies47

 6.3 Startup Considerations52

 6.4 Power-on-Reset, Brownout and Supply Monitor52

7 Low Power Techniques 54

 7.1 Power Save Modes54

 7.2 Power Scaling59

8	<i>Debug and Test</i>	61
8.1	Features	61
8.2	Overview	61
8.3	Block diagram	62
8.4	I/O Lines Description	62
8.5	Product dependencies	63
8.6	Core debug	63
8.7	Enhanced Debug Port (EDP)	66
8.8	AHB-AP Access Port	76
8.9	System Manager Access Port (SMAP)	77
8.10	Available Features in Protected State	92
8.11	Functional Description	93
9	<i>Electrical Characteristics</i>	98
9.1	Absolute Maximum Ratings*	98
9.2	Operating Conditions	98
9.3	Supply Characteristics	98
9.4	Maximum Clock Frequencies	100
9.5	Power Consumption	102
9.6	I/O Pin Characteristics	113
9.7	Oscillator Characteristics	120
9.8	Flash Characteristics	126
9.9	Analog Characteristics	128
9.10	Timing Characteristics	139
10	<i>Mechanical Characteristics</i>	152
10.1	Thermal Considerations	152
10.2	Package Drawings	153
10.3	Soldering Profile	162
11	<i>Ordering Information</i>	163
12	<i>Errata</i>	166
12.1	ATSAM4L4 /2 Rev. B & ATSAM4L8 Rev. A	166
13	<i>Datasheet Revision History</i>	169
13.1	Rev. A – 09/12	169
13.2	Rev. B – 10/12	169
13.3	Rev. C – 02/13	169



13.4	Rev. D – 03/13	169
13.5	Rev. E – 07/13	170

Table of Contents.....	171
-------------------------------	------------

Atmel Corporation

2325 Orchard Parkway
San Jose, CA 95131
USA

Tel: (+1)(408) 441-0311
Fax: (+1)(408) 487-2600

www.atmel.com

Atmel Asia Limited

Unit 1-5 & 16, 19/F
BEA Tower, Millennium City 5
418 Kwun Tong Road
Kwun Tong, Kowloon
HONG KONG

Tel: (+852) 2245-6100
Fax: (+852) 2722-1369

Atmel Munich GmbH

Business Campus
Parkring 4
D-85748 Garching b. Munich
GERMANY

Tel: (+49) 89-31970-0
Fax: (+49) 89-3194621

Atmel Japan

16F, Shin Osaki Kangyo Bldg.
1-6-4 Osaka Shinagawa-ku
Tokyo 104-0032
JAPAN

Tel: (+81) 3-6417-0300
Fax: (+81) 3-6417-0370

© 2013 Atmel Corporation. All rights reserved. 09103

Atmel®, Atmel logo and combinations thereof, picoPower®, Adjacent Key Suppression®, AKS®, Qtouch®, and others are registered trademarks or trademarks of Atmel Corporation or its subsidiaries. ARM®, AMBA®, Thumb®, Cortex™ are registered trademarks or trademarks of ARM Ltd. Other terms and product names may be trademarks of others.

Disclaimer: The information in this document is provided in connection with Atmel products. No license, express or implied, by estoppel or otherwise, to any intellectual property right is granted by this document or in connection with the sale of Atmel products. **EXCEPT AS SET FORTH IN THE ATMEL TERMS AND CONDITIONS OF SALES LOCATED ON THE ATMEL WEBSITE, ATMEL ASSUMES NO LIABILITY WHATSOEVER AND DISCLAIMS ANY EXPRESS, IMPLIED OR STATUTORY WARRANTY RELATING TO ITS PRODUCTS INCLUDING, BUT NOT LIMITED TO, THE IMPLIED WARRANTY OF MERCHANTABILITY, FITNESS FOR A PARTICULAR PURPOSE, OR NON-INFRINGEMENT. IN NO EVENT SHALL ATMEL BE LIABLE FOR ANY DIRECT, INDIRECT, CONSEQUENTIAL, PUNITIVE, SPECIAL OR INCIDENTAL DAMAGES (INCLUDING, WITHOUT LIMITATION, DAMAGES FOR LOSS AND PROFITS, BUSINESS INTERRUPTION, OR LOSS OF INFORMATION) ARISING OUT OF THE USE OR INABILITY TO USE THIS DOCUMENT, EVEN IF ATMEL HAS BEEN ADVISED OF THE POSSIBILITY OF SUCH DAMAGES.** Atmel makes no representations or warranties with respect to the accuracy or completeness of the contents of this document and reserves the right to make changes to specifications and product descriptions at any time without notice. Atmel does not make any commitment to update the information contained herein. Unless specifically provided otherwise, Atmel products are not suitable for, and shall not be used in, automotive applications. Atmel products are not intended, authorized, or warranted for use as components in applications intended to support or sustain life.