

5V power supply, 1Mbps high-speed CAN transceiver

FEATURES

- Full compatible with ISO 11898 standard
- Thermally protected
- Over-current protection function
- Low-current standby mode (<math><5\mu\text{A}</math>)
- Unpowered nodes don't interfere with the bus
- At least 110 nodes can be connected
- High-speed CAN, transmit rate up to 1 Mbps
- High anti-electromagnetic interference ability

PRODUCT APPEARANCE

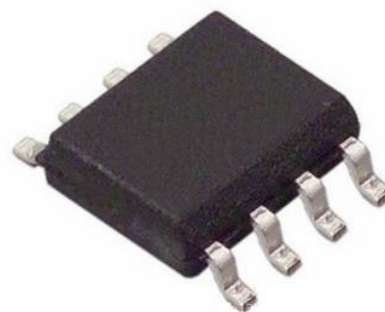

Provide Green and Environmentally Friendly
Lead-free package

DESCRIPTION

SL82C250 is the interface between the Controller Area Network (CAN) protocol controller and the physical bus. It is primarily intended for applications up to 1Mbps and is used for in-vehicle and industrial control. The device provides differential transmit capability to the bus and differential receive capability to the CAN controller.

PARAMETER	SYMBOL	CONDITION	MIN.	MAX.	UNIT
Supply voltage	V_{cc}		4.5	5.5	V
Supply current	I_{cc}	Standby mode		10	μA
Maximum transmission rate	$1/t_{\text{bit}}$	Non-return to zero code	1		Mbaud
CANH, CANL withstand voltage	V_{can}		-8	+18	V
Bus differential voltage	V_{diff}		1.5	3.0	V
Ambient temperature	T_{amb}		-40	125	$^{\circ}\text{C}$

PIN CONFIGURATION

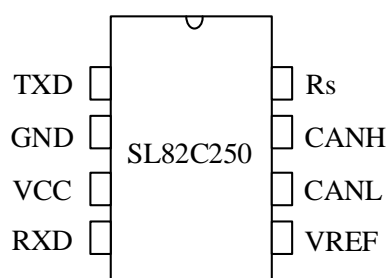

PIN DESCRIPTION

PIN	SYMBOL	DESCRIPTION
1	TXD	transmit data input
2	GND	ground supply
3	VCC	supply voltage
4	RXD	receive data output
5	VREF	reference voltage output
6	CANL	LOW-level CAN voltage input/output
7	CANH	HIGH-level CAN voltage input/output
8	Rs	Standby mode control input

LIMITING VALUES

PARAMETER	SYMBOL	VALUE	UNIT
Supply voltage	V_{CC}	-0.3~+7	V
MCU side port	TXD, RXD, VREF, Rs	-0.3~VCC+0.3	V
Bus side input voltage	CANL, CANH	-8~18	V
Transient voltage at pin 6, 7 See Fig 7	V_{tr}	-200~+200	V
Storage temperature	T_{stg}	-55~150	°C
Virtual junction temperature	T_j	-40~150	°C
Ambient temperature	T_{amb}	-40~125	°C
Welding temperature range		300	°C
Continuous power consumption	SOP8	400	mW
	DIP8	700	mW

The maximum limit parameters mean that exceeding these values may cause irreversible damage to the device. Under these conditions, it is not conducive to the normal operation of the device. The continuous operation of the device at the maximum allowable rating may affect the reliability of the device. The reference point for all voltages is ground.

DRIVER ELECTRICAL CHARACTERISTICS

PARAMETER	SYMBOL	CONDITION	MIN.	TYP.	MAX.	UNIT
CANH dominant output voltage	$V_{OH(D)}$	$V_I=0V, R_s=0V,$ $R_L=60\Omega,$ Fig 1, Fig 2	2.9	3.4	4.5	
CANL dominant output voltage	$V_{OL(D)}$		0.8		1.5	
Bus recessive output voltage	$V_{O(R)}$	$V_I=3V, R_s=0V,$ $R_L=60\Omega,$ Fig 1, Fig 2	2	2.5	3	V
Bus dominant differential output voltage	$V_{OD(D)}$	$V_I=0V, R_s=0V,$ $R_L=60\Omega,$ Fig 1, Fig 2	1.5		3	V
Bus recessive differential output voltage	$V_{OD(R)}$	$V_I=3V, R_s=0V,$ Fig 1, Fig 2	-0.012		0.012	V
		$V_I=3V, R_s=0V,$ NO LOAD	-0.5		0.05	V
Transmitter dominant voltage symmetry	$V_{dom(TX)sym}$	$V_{dom(TX)sym}=V_{CC}-$ $V_{CANH} - V_{CANL}$	-400		400	mV
Transmitter voltage symmetry	V_{TXsym}	$V_{TXsym}= V_{CANH} +$ V_{CANL}	$0.9V_{CC}$		$1.1V_{CC}$	V
Common-mode output voltage	V_{OC}	$R_s=0V,$ Fig 8	2	2.5	3	V
Peak-to-peak Common-mode output voltage	ΔV_{OC}			30		mV
Short-circuit output current	I_{OS}	CANH=-12V, CANL=open, Fig 10	-105	-72		mA
		CANH=12V, CANL=open, Fig 10		0.36	1	
		CANL=-12V, CANH=open, Fig 10	-1	0.5		
		CANL=12V, CANH=open, Fig 10		71	105	
Recessive output current	$I_{O(R)}$	$-27V < CANH < 32V$ $0 < V_{CC} < 5.25V$	-2.0		2.5	mA

(Unless specified otherwise, $V_{CC}=5V \pm 10\%$, $-40^\circ C \leq T_{amb} \leq 125^\circ C$, typical in $V_{CC}=+5V$, $T_{amb}=25^\circ C$).

DRIVER SWITCHING CHARACTERISTICS

PARAMETER	SYMBOL	CONDITION	MIN.	TYP.	MAX.	UNIT
Propagation delay time, low-to-high-level output	t_{PLH}	$R_s=0V$, Fig 4	25	65	120	ns
Propagation delay time, high-to-low-level output	t_{PHL}		25	45	90	ns
Differential output signal rise time	t_r			25		ns
Differential output signal fall time	t_f			50		ns
Enable time from standby mode to dominant	t_{EN}	Fig 7			10	μs
Bus wake-up filter time	t_{BUS}		0.7		5	μs

(Unless specified otherwise, $V_{CC}=5V\pm 10\%$, $-40^\circ C \leq T_{amb} \leq 125^\circ C$, typical in $V_{CC}=+5V$, $T_{amb}=25^\circ C$).

RECEIVER ELECTRICAL CHARACTERISTICS

PARAMETER	SYMBOL	CONDITION	MIN.	TYP.	MAX.	UNIT
Positive-going input threshold voltage	V_{IT+}	$R_s=0V$, Fig 5		800	900	mV
Negative-going input threshold voltage	V_{IT-}		500	650		
Hysteresis voltage ($V_{IT+} - V_{IT-}$)	V_{HYS}		100	125		
High-level output voltage	V_{OH}	$I_O=-2mA$, Fig 6	4	4.6		V
Low-level output voltage	V_{OL}	$I_O=2mA$, Fig 6		0.2	0.4	V
Power-off bus input current	$I_{(OFF)}$	CANH or CANL=5V, Other pin=0V			5	μA
Input capacitance to ground (CANH or CANL)	C_I			13		pF
Differential input capacitance	C_{ID}			5		pF
Input resistance, (CANH or CANL)	R_{IN}	TXD=3V, $R_s=0V$	15	30	40	k Ω
Differential input resistance	R_{ID}		30		80	k Ω

PARAMETER	SYMBOL	CONDITION	MIN.	TYP.	MAX.	UNIT
Input resistance matching	$R_{I_{match}}$	CANH=CANL	-3%		3%	
The range of common-mode voltage	V_{COM}		-12		12	V

(Unless specified otherwise, $V_{CC}=5V\pm 10\%$, $-40^{\circ}C \leq T_{amb} \leq 125^{\circ}C$, typical in $V_{CC}=+5V$, $T_{amb}=25^{\circ}C$).

RECEIVER SWITCHING CHARACTERISTICS

PARAMETER	SYMBOL	CONDITION	MIN.	TYP.	MAX.	UNIT
Propagation delay time, low-to-high-level output	t_{PLH}	$R_s=0V$ or V_{CC} , Fig 6	60	100	130	ns
Propagation delay time, high-to-low-level output	t_{PHL}		45	70	90	ns
RXD signal rise time	t_r			8		ns
RXD signal fall time	t_f			8		ns

(Unless specified otherwise, $V_{CC}=5V\pm 10\%$, $-40^{\circ}C \leq T_{amb} \leq 125^{\circ}C$, typical in $V_{CC}=+5V$, $T_{amb}=25^{\circ}C$).

DEVICE SWITCHING CHARACTERISTICS

PARAMETER	SYMBOL	CONDITION	MIN.	TYP.	MAX.	UNIT
Loop delay 1, driver input to receiver output, Recessive to Dominant	$t_{d(LOOP1)}$	$R_s=0V$, Fig 9	90		190	ns
Loop delay 2, driver input to receiver output, Dominant to Recessive	$t_{d(LOOP2)}$		90		190	ns

(Unless specified otherwise, $V_{CC}=5V\pm 10\%$, $-40^{\circ}C \leq T_{amb} \leq 125^{\circ}C$, typical in $V_{CC}=+5V$, $T_{amb}=25^{\circ}C$).

OVER TEMPERATURE PROTECTION

PARAMETER	SYMBOL	CONDITION	MIN.	TYP.	MAX.	UNIT
Shutdown junction temperature	$T_{j(sd)}$			160		$^{\circ}C$

DEVICE SWITCHING CHARACTERISTICS

PARAMETER	SYMBOL	CONDITION	MIN.	TYP.	MAX.	UNIT
HIGH-level input current	$I_{IH}(TXD)$	$V_I=V_{CC}$	-2		2	μA
LOW-level input current	$I_{IL}(TXD)$	$V_I=0$	-50		-10	μA
When $V_{CC}=0V$, current on TXD pin	$I_{O(off)}$	$V_{CC}=0V, TXD=5V$			1	μA
HIGH-level input voltage	V_{IH}		2		$V_{CC}+0.3$	V
LOW-level input voltage	V_{IL}		-0.3		0.8	V
Open voltage on TXD pin	TXD_O		H			logic

(Unless specified otherwise, $V_{CC}=5V\pm 10\%$, $-40^{\circ}C \leq T_{amb} \leq 125^{\circ}C$, typical in $V_{CC}=+5V$, $T_{amb}=25^{\circ}C$).

COMMON-MODE STABILIZATION OUTPUT

PARAMETER	SYMBOL	CONDITION	MIN.	TYP.	MAX.	UNIT
Common-mode stabilization output voltage	V_O	$-500\mu A < I_O < 500\mu A$	$0.3V_{CC}$		$0.7V_{CC}$	V
Leakage current	$I_{O(Rs)}$	$R_s=2V,$ $-12V < V_O < 12V$	-5		5	μA

(Unless specified otherwise, $V_{CC}=5V\pm 10\%$, $-40^{\circ}C \leq T_{amb} \leq 125^{\circ}C$, typical in $V_{CC}=+5V$, $T_{amb}=25^{\circ}C$).

SUPPLY CURRENT

PARAMETER	SYMBOL	CONDITION	MIN.	TYP.	MAX.	UNIT
Standby	I_{CC}	$R_s=V_{CC}, V_I=V_{CC}$		5	12	μA
Dominant		$V_I=0V, R_s=0V,$ $LOAD=60\Omega$		50	70	mA
Recessive		$V_I=V_{CC}, R_s=0V,$ NO LOAD		6	10	mA

(Unless specified otherwise, $V_{CC}=5V\pm 10\%$, $-40^{\circ}C \leq T_{amb} \leq 125^{\circ}C$, typical in $V_{CC}=+5V$, $T_{amb}=25^{\circ}C$).

ESD PERFORMANCE

PARAMETER	SYMBOL	CONDITION	MIN.	TYP.	MAX.	UNIT
CAN bus pin human body discharge model (HBM)	V_{ESD_HBM}		-8		+8	kV

FUNCTION TABLE
Table 1 CAN TRANSCEIVER TRUTH TABLE

V_{CC}	TXD ⁽¹⁾	Rs ⁽¹⁾	CANH ⁽¹⁾	CANL ⁽¹⁾	BUS STATE	RXD ⁽¹⁾
4.5V~5.5V	L	L	H	L	Dominate	L
4.5V~5.5V	H or Open	X	0.5V _{CC}	0.5V _{CC}	Recessive	H
4.5V~5.5V	X	H or Open	0.5V _{CC}	0.5V _{CC}	Recessive	H
0<V _{CC} <4.5V	X	X	0V<V _{CANH} <V _{CC}	0V<V _{CANL} <V _{CC}	Recessive	X

(1) H=high level; L=low level; X=irrelevant.

Table 2 DRIVER FUNCTION TABLE

INPUTS		OUTPUTS		Bus State
TXD ⁽¹⁾	Rs ⁽¹⁾	CANH ⁽¹⁾	CAL ⁽¹⁾	
L	L	H	L	Dominate
H or open	X	Z	Z	Recessive
X	H or open	Z	Z	Recessive

(1) H=high level; L=low level; X=irrelevant; Z=high impedance.

Table 3 RECEIVER FUNCTION TABLE

V _{ID} =CANH-CANL	RXD ⁽¹⁾	Bus State ⁽¹⁾
V _{ID} ≥0.9V	L	Dominate
0.5<V _{ID} <0.9V	?	?
V _{ID} ≤0.5V	H	Recessive
Open	H	Recessive

(1) H=high-level; L=low-level; ?=uncertain.

TEST CIRCUIT

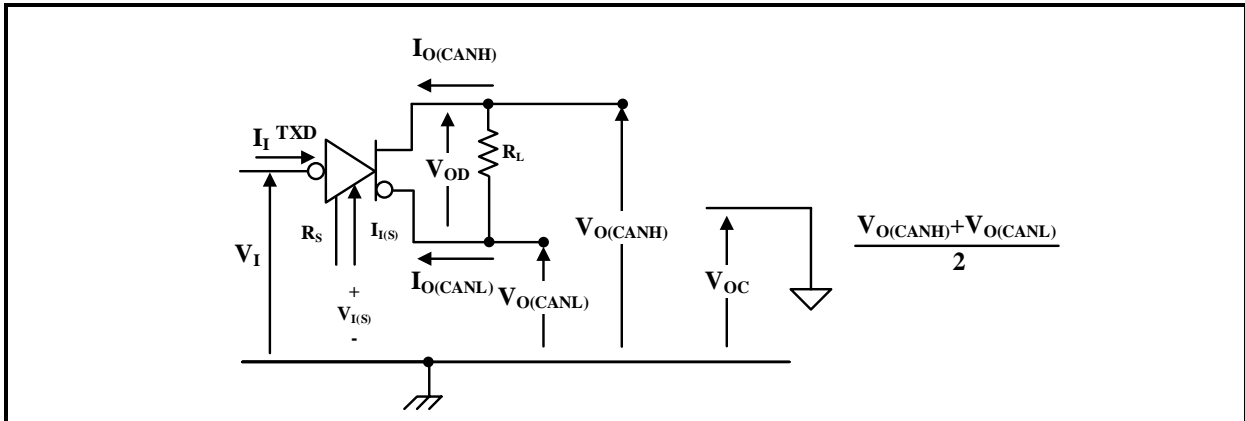

Fig 1 Driver Voltage, Current, and Test Definition

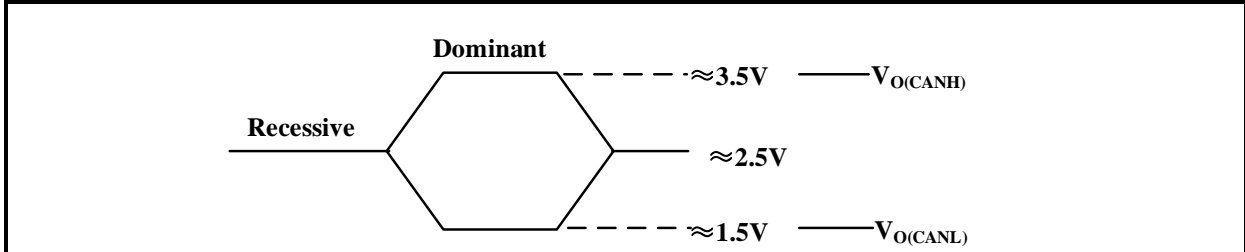

Fig 2 Bus Logic State Voltage Definition

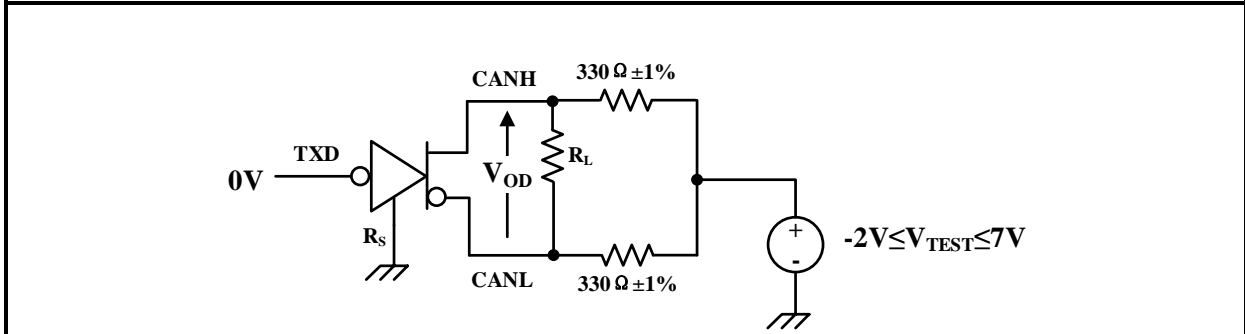

Fig 3 Driver VOD Test Circuit

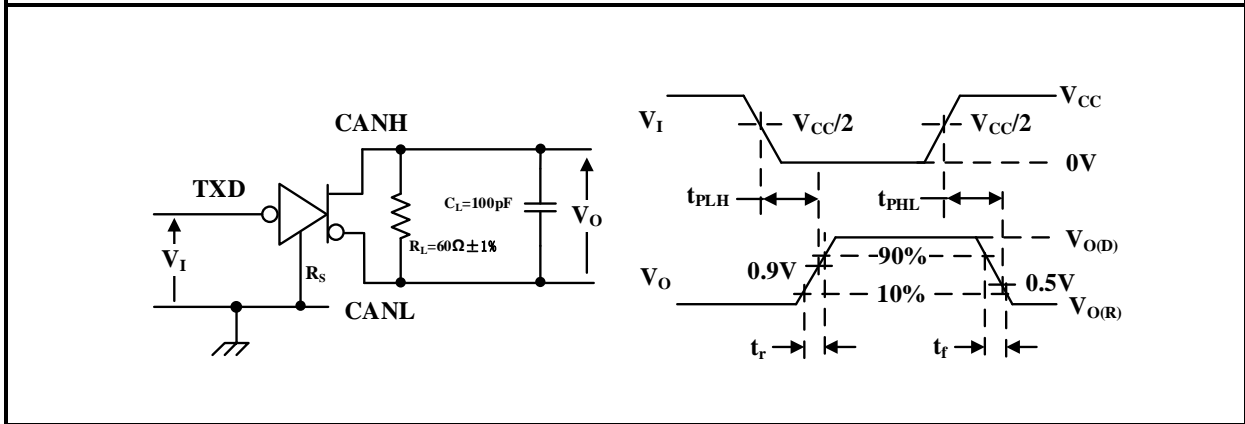

Fig 4 Driver Test Circuit and Waveform

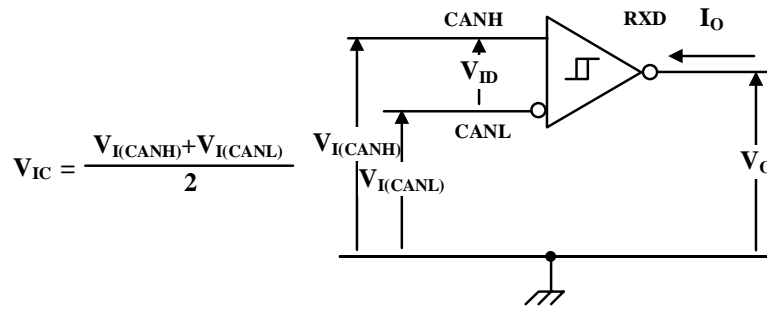
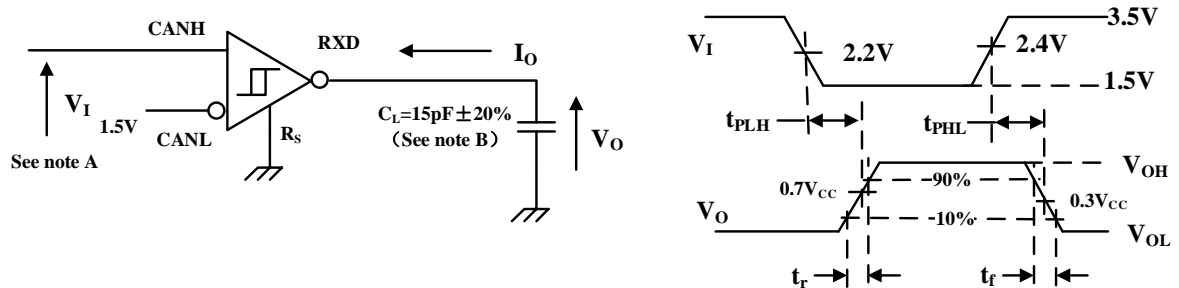

Fig 5 Receiver Voltage and Current Definition



A: The input pulse is supplied by a generator having the following characteristics: PRR ≤ 125kHz, 50% duty cycle, $t_r < 6ns$, $t_f < 6ns$, $Z_o = 50\Omega$;

B: C_L includes instrumentation and fixture capacitance within ±20%.

Fig 6 Receiver Test Circuit and Waveform

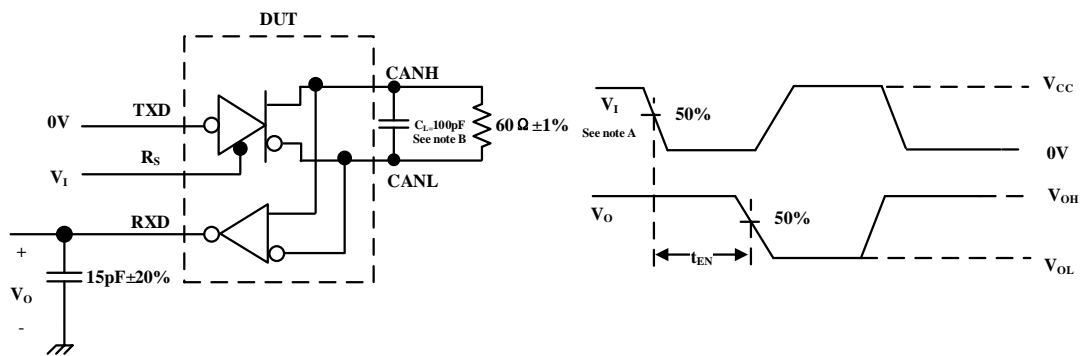

A: All V_I input pulses are supplied by a generator having the following characteristics: PRR ≤ 25kHz, 50% duty cycle, $t_r < 6ns$, $t_f < 6ns$;

B: C_L includes instrumentation and fixture capacitance within ±20%.

Fig 7 t_{EN} Test Circuit and Waveform

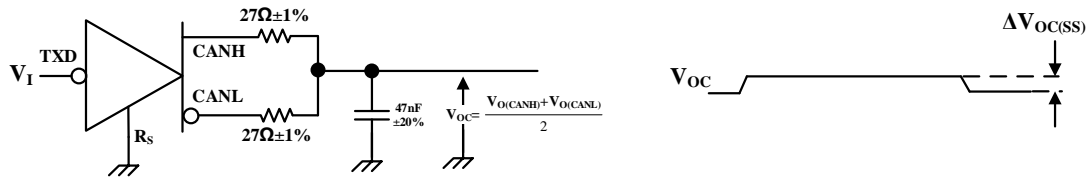

NOTE: V_I ranges from 0 to V_{CC} , the input pulse is supplied by a generator having the following characteristics: $PRR \leq 125\text{kHz}$, 50% duty cycle, $t_r < 6\text{ns}$, $t_f < 6\text{ns}$, $Z_o = 50\Omega$.

Fig 8 Common Mode Output Voltage Test and Waveform

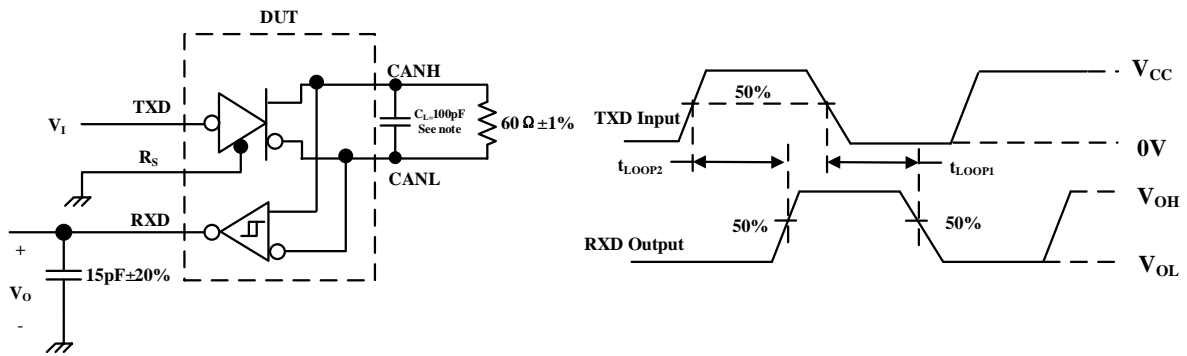

NOTE: C_L includes instrumentation and fixture capacitance within $\pm 20\%$.

Fig 9 t_{LOOP} Test Circuit and Waveform

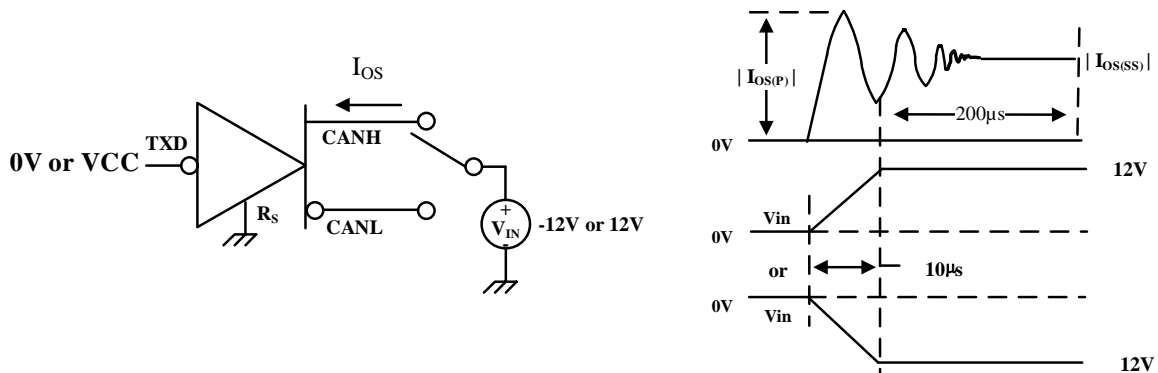

Fig 10 Driver Short-Circuit Current Test Circuit and Waveform

ADDITIONAL DESCRIPTION

1 Sketch

SL82C250 is an interface chip applied between the CAN protocol controller and the physical bus. It is primarily intended for applications up to 1 Mbps and can be used for in-vehicle and industrial control and other fields. The device provides differential transmit capability to the bus and differential receive capability to the CAN controller. It is fully compatible with the ISO 11898 standard.

2 Short circuit protection

The driver stage of SL82C250 has a current-limiting protection function to prevent the driver circuit from being short-circuited to the positive and negative power supply voltages. When a short-circuit occurs, the power consumption will increase. The short-circuit protection function can protect the driver stage from damage.

3 Overtemperature protect

SL82C250 has an over-temperature protection function. When the junction temperature exceeds 160°C, the current of the driver stage will be reduced, because the driver tube is the main energy-consuming part, and the current reduction can reduce the power consumption and thus reduce the chip temperature. At the same time, other parts of the chip are still working normally.

4 Electrical transient protection

Electrical transients often occur in automotive application environments. CANH and CANL of SL82C250 have the function of preventing electrical transient damage.

5 Control mode

The control pin Rs allows two working modes to be selected:

High-speed mode or low-power standby mode.

The high-speed mode is a normal operating mode and is selected by grounding the pin Rs. The transceiver can send and receive data through the bus CANH and CANL. The differential receiver converts the analog data on the bus into digital data, and outputs it to the pin RXD through a multiplexer (MUX).

If the pin Rs is connected to a high level or not connected, it works in a low-power standby mode. In the low-power standby mode, the transmitter is turned off and the receiver enters a low current state. If the receiver detects the bus dominance (bus differential voltage > 0.9V), RXD switches to low level, the MCU needs to respond to this action at this time, and enter the normal operating state by controlling the Rs pin. Because in the standby state, the current is small and the response time is longer, the first signal may be lost at a higher baud rate.

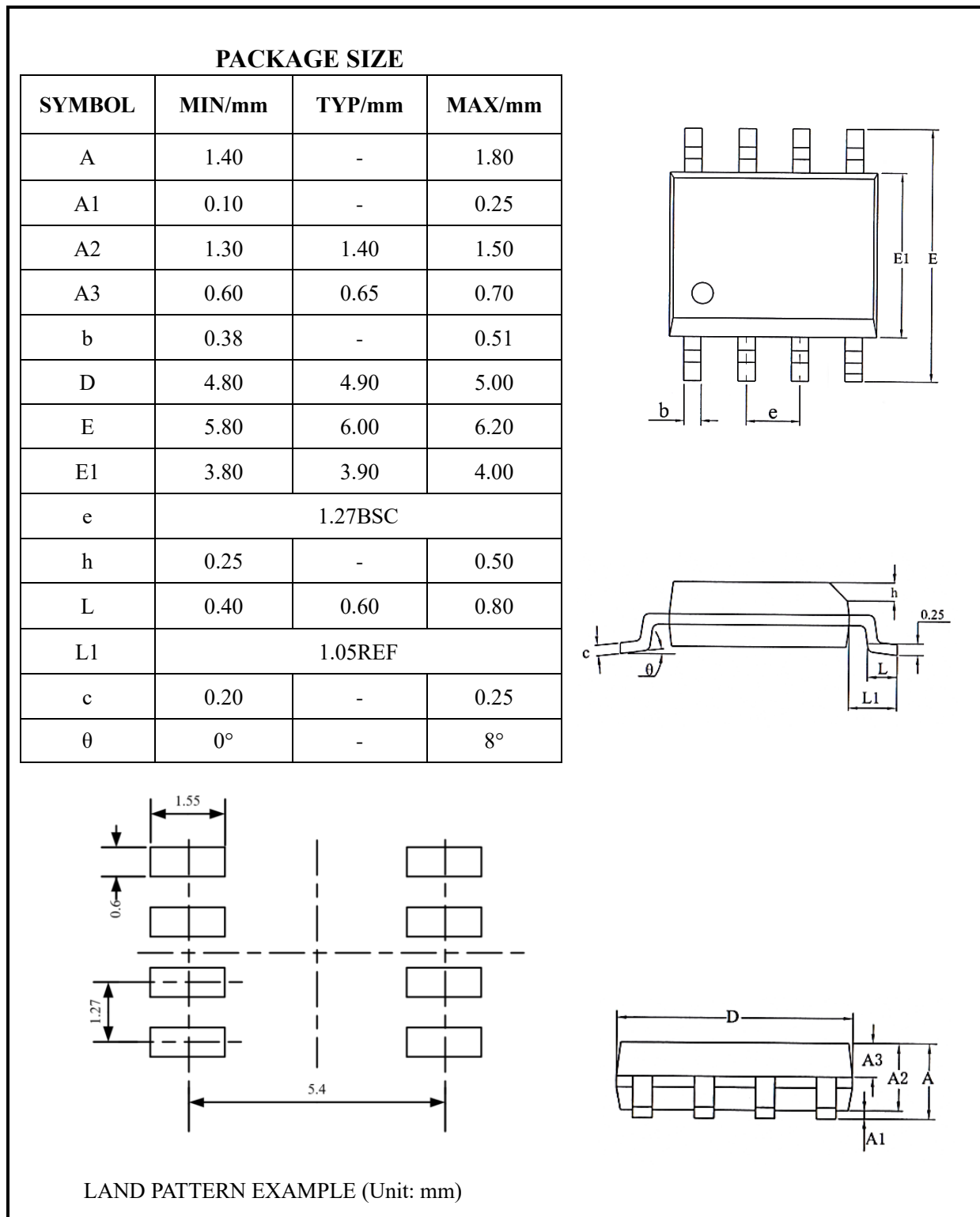
SOP8 DIMENSIONS

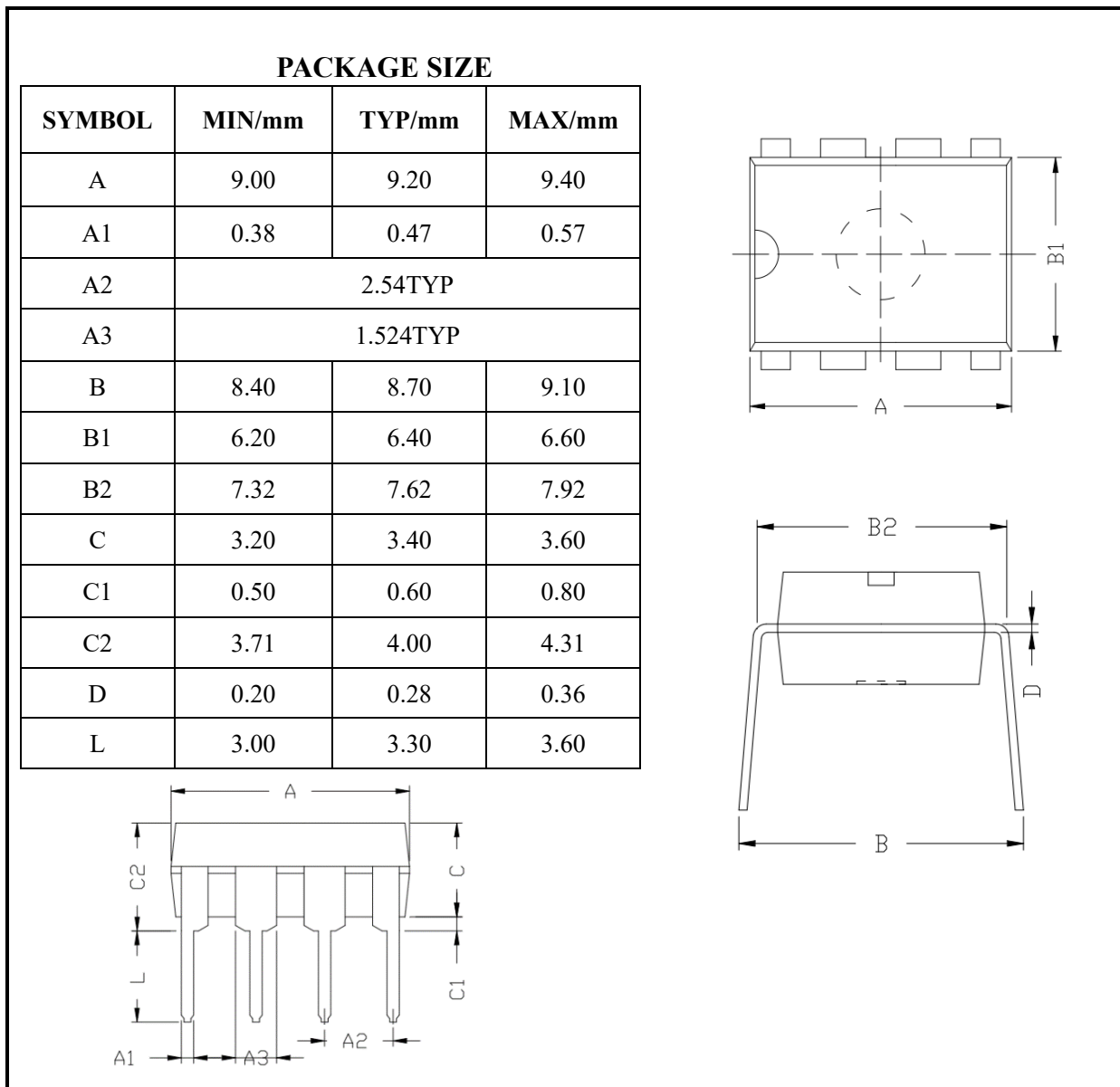
DIP8 DIMENSIONS

ORDERING INFORMATION

Type number	package	packing
SL82C250T	SOP8	Tape and reel
SL82C250	DIP8	Tube

SOP8 is packed with 2500 pieces/disc in braided packaging. DIP8 is packed with 50 pieces/tube in tubed packaging.

REFLOW SOLDERING

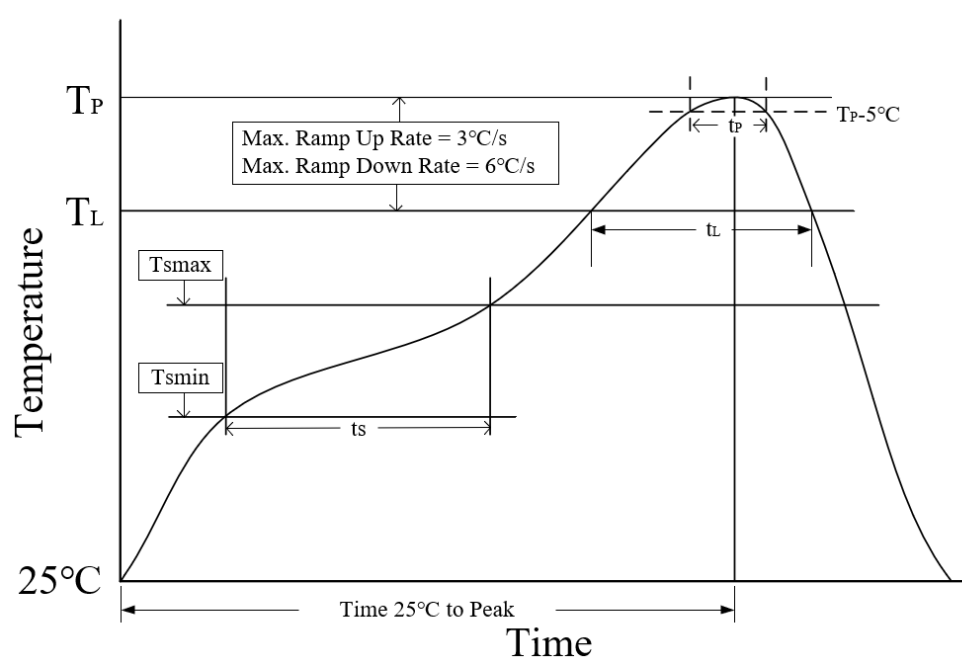

Parameter	Lead-free soldering conditions
Ave ramp up rate (T_L to T_P)	3°C/second max
Preheat time t_s ($T_{smin}=150\text{ °C}$ to $T_{smax}=200\text{ °C}$)	60-120 seconds
Melting time t_L ($T_L=217\text{ °C}$)	60-150 seconds
Peak temp T_P	260-265°C
5°C below peak temperature t_p	30 seconds
Ave cooling rate (T_P to T_L)	6°C/second max
Normal temperature 25°C to peak temperature T_P time	8 minutes max