



**Enhanced Poly-Phase  
High-Performance Wide-Span  
Energy Metering IC  
90E32AS**

Version 1.0  
April 2, 2013

---



**Atmel Corporation** 1600 Technology Drive, San Jose, CA 95110 USA T: (+1)(408) 441.0311 F: (+1)(408) 436.4200 | [www.atmel.com](http://www.atmel.com)

© 2013 Atmel Corporation. All rights reserved. / Rev.: Atmel-Meter-ATM90E32AS-Datasheet-Eng\_042013

Atmel®, Atmel logo and combinations thereof, Enabling Unlimited Possibilities®, and others are registered trademarks or trademarks of Atmel Corporation or its subsidiaries. Other terms and product names may be trademarks of others.

**DISCLAIMER:** The information in this document is provided in connection with Atmel products. No license, express or implied, by estoppel or otherwise, to any intellectual property right is granted by this document or in connection with the sale of Atmel products. EXCEPT AS SET FORTH IN THE ATMEL TERMS AND CONDITIONS OF SALES LOCATED ON THE ATMEL WEBSITE, ATMEL ASSUMES NO LIABILITY WHATSOEVER AND DISCLAIMS ANY EXPRESS, IMPLIED OR STATUTORY WARRANTY RELATING TO ITS PRODUCTS INCLUDING, BUT NOT LIMITED TO, THE IMPLIED WARRANTY OF MERCHANTABILITY, FITNESS FOR A PARTICULAR PURPOSE, OR NON-INFRINGEMENT. IN NO EVENT SHALL ATMEL BE LIABLE FOR ANY DIRECT, INDIRECT, CONSEQUENTIAL, PUNITIVE, SPECIAL OR INCIDENTAL DAMAGES (INCLUDING, WITHOUT LIMITATION, DAMAGES FOR LOSS AND PROFITS, BUSINESS INTERRUPTION, OR LOSS OF INFORMATION) ARISING OUT OF THE USE OR INABILITY TO USE THIS DOCUMENT, EVEN IF ATMEL HAS BEEN ADVISED OF THE POSSIBILITY OF SUCH DAMAGES. Atmel makes no representations or warranties with respect to the accuracy or completeness of the contents of this document and reserves the right to make changes to specifications and products descriptions at any time without notice. Atmel does not make any commitment to update the information contained herein. Unless specifically provided otherwise, Atmel products are not suitable for, and shall not be used in, automotive applications. Atmel products are not intended, authorized, or warranted for use as components in applications intended to support or sustain life.

**SAFETY-CRITICAL, MILITARY, AND AUTOMOTIVE APPLICATIONS DISCLAIMER:** Atmel products are not designed for and will not be used in connection with any applications where the failure of such products would reasonably be expected to result in significant personal injury or death ("Safety-Critical Applications") without an Atmel officer's specific written consent. Safety-Critical Applications include, without limitation, life support devices and systems, equipment or systems for the operation of nuclear facilities and weapons systems. Atmel products are not designed nor intended for use in military or aerospace applications or environments unless specifically designated by Atmel as military-grade. Atmel products are not designed nor intended for use in automotive applications unless specifically designated by Atmel as automotive-grade.

FEATURES .....	7
APPLICATION .....	7
GENERAL DESCRIPTION .....	7
BLOCK DIAGRAM .....	8
1 PIN ASSIGNMENT .....	9
2 PIN DESCRIPTION .....	10
3 FUNCTION DESCRIPTION .....	12
3.1 POWER SUPPLY .....	12
3.2 CLOCK .....	12
3.3 RESET .....	12
3.3.1 RESET Pin .....	12
3.3.2 Power On Reset (POR) .....	12
3.3.3 Software Reset .....	12
3.4 ANALOG/DIGITAL CHANNEL MAPPING .....	13
3.5 METERING FUNCTION .....	14
3.5.1 Theory of Energy Registers .....	14
3.5.2 Energy Registers .....	16
3.5.3 Energy Pulse Output .....	16
3.5.4 Startup and No-load Power .....	17
3.6 MEASUREMENT FUNCTION .....	19
3.6.1 Active/ Reactive/ Apparent Power .....	19
3.6.2 Fundamental / Harmonic Active Power .....	19
3.6.3 Mean Power Factor (PF) .....	19
3.6.4 Voltage / Current RMS .....	19
3.6.5 Phase Angle .....	20
3.6.6 Frequency .....	20
3.6.7 Temperature .....	20
3.6.8 Peak Value .....	20
3.7 POWER QUALITY MONITORING .....	21
3.7.1 Instantaneous Signal Monitoring .....	21
3.7.2 Instantaneous Signal Related Status And Events .....	21
3.7.3 Frequency Monitoring Related Status And Events .....	22
3.7.4 Zero-Crossing Detection .....	22
3.7.5 Neutral Line Overcurrent Detection .....	22
3.7.6 Phase Sequence Error Detection .....	22
3.8 POWER MODE .....	23
3.8.1 Normal Mode (N Mode) .....	23
3.8.2 Idle Mode (I Mode) .....	24
3.8.3 Detection Mode (D Mode) .....	26
3.8.4 Partial Measurement mode (M Mode) .....	27
3.8.5 Transition of Power Modes .....	28
3.9 EXTERNAL COMPONENT COMPENSATION .....	29
3.9.1 Gain Based Compensation .....	29
3.9.2 Delay/Phase Based Compensation .....	30
4 SPI INTERFACE .....	31
4.1 INTERFACE DESCRIPTION .....	31
4.2 SPI INTERFACE .....	32

4.2.1	SPI Slave Interface Format .....	32
4.2.2	Reliability Enhancement Feature .....	32
<b>5</b>	<b>REGISTER .....</b>	<b>33</b>
5.1	REGISTER LIST .....	33
5.2	SPECIAL REGISTERS .....	40
5.2.1	Configuration Registers CRC Generation .....	40
5.2.2	IRQ and WarnOut Signal Generation .....	41
5.2.3	Special Configuration Registers .....	45
5.3	LOW-POWER MODES REGISTERS .....	48
5.3.1	Detection Mode Registers .....	48
5.3.2	Partial Measurement mode Registers .....	50
5.4	CONFIGURATION AND CALIBRATION REGISTERS .....	55
5.4.1	Configuration Registers .....	55
5.4.2	Energy Calibration Registers .....	57
5.4.3	Fundamental/Harmonic Energy Calibration registers .....	58
5.4.4	Measurement Calibration .....	59
5.4.5	EMM Status .....	59
5.5	ENERGY REGISTER .....	66
5.5.1	Regular Energy Registers .....	66
5.5.2	Fundamental / Harmonic Energy Register .....	67
5.6	MEASUREMENT REGISTERS .....	68
5.6.1	Power and Power Factor Registers .....	68
5.6.2	Fundamental/ Harmonic Power and Voltage/ Current RMS Registers .....	68
5.6.3	Peak, Frequency, Angle and Temperature Registers .....	69
<b>6</b>	<b>ELECTRICAL SPECIFICATION .....</b>	<b>71</b>
6.1	ELECTRICAL SPECIFICATION .....	71
6.2	METERING/ MEASUREMENT ACCURACY .....	73
6.2.1	Metering Accuracy .....	73
6.2.2	Measurement Accuracy .....	74
6.3	INTERFACE TIMING .....	75
6.3.1	SPI Interface Timing (Slave Mode) .....	75
6.4	POWER ON RESET TIMING .....	76
6.5	ZERO-CROSSING TIMING .....	77
6.6	VOLTAGE SAG AND PHASE LOSS TIMING .....	78
6.7	ABSOLUTE MAXIMUM RATING .....	79
	PACKAGE DIMENSIONS.....	80
	ORDERING INFORMATION.....	81
	DATASHEET DOCUMENT HISTORY.....	81



# List of Tables

---

Table-1	Pin Description .....	10
Table-2	Power Mode Mapping .....	23
Table-3	Digital I/O and Power Pin States in Idle Mode .....	24
Table-4	Compensation Related Registers .....	29
Table-5	Register List .....	33
Table-6	Configuration Registers .....	55
Table-7	Calibration Registers .....	57
Table-8	Fundamental/Harmonic Energy Calibration Registers .....	58
Table-9	Measurement Calibration Registers .....	59
Table-10	EMM Status Registers .....	59
Table-11	Regular Energy Registers .....	66
Table-12	Fundamental / Harmonic Energy Register .....	67
Table-13	Power and Power Factor Register .....	68
Table-14	Fundamental/ Harmonic Power and Voltage/ Current RMS Registers .....	68
Table-15	Peak, Frequency, Angle and Temperature Registers .....	69
Table-16	Metering Accuracy for Different Energy within the Dynamic Range .....	73
Table-17	Measurement Parameter Range and Format .....	74
Table-18	SPI Timing Specification .....	75
Table-19	Power On Reset Specification .....	76
Table-20	Zero-Crossing Specification .....	77

---

Figure-1	90E32AS Block Diagram .....	8
Figure-2	Pin Assignment (Top View) .....	9
Figure-3	Channel to Phase Mapping .....	13
Figure-4	Energy Accumulation Diagram .....	15
Figure-5	CFx Pulse Output Regulation .....	16
Figure-6	Active Power Startup/No-load Processing .....	17
Figure-7	Fundamental Active Power Startup/No-load Processing .....	17
Figure-8	Harmonic Active Power Startup/No-load Processing .....	18
Figure-9	Power Quality Monitor in Datapath .....	21
Figure-10	Block Diagram in Normal Mode .....	23
Figure-11	Block Diagram in Idle Mode .....	24
Figure-12	Block Diagram in Detection Mode .....	26
Figure-13	Block Diagram in Partial Measurement mode .....	27
Figure-14	Power Mode Transition .....	28
Figure-15	Segment Gain Compensation .....	30
Figure-16	Slave Mode .....	31
Figure-17	Read Sequence .....	32
Figure-18	Write Sequence .....	32
Figure-19	CRC Checking Diagram .....	40
Figure-20	IRQ and WarnOut Generation .....	41
Figure-21	Current Detection Register Latching Scheme .....	48
Figure-22	SPI Timing Diagram .....	75
Figure-23	Power On Reset Timing (90E32AS and MCU are Powered on Simultaneously) .....	76
Figure-24	Power On Reset Timing in Normal & Partial Measurement Mode .....	76
Figure-25	Zero-Crossing Timing Diagram (per phase) .....	77
Figure-26	Voltage Sag and Phase Loss Timing Diagram .....	78

## FEATURES

### Metering Features

- Metering features fully in compliance with the requirements of IEC62052-11, IEC62053-22 and IEC62053-23, ANSI C12.1 and ANSI C12.20; applicable in poly-phase class 0.5S or class 1 watt-hour meter or class 2 var-hour meter.
- Accuracy of  $\pm 0.1\%$  for active energy and  $\pm 0.2\%$  for reactive energy over a dynamic range of 6000:1.
- Temperature coefficient is 6 ppm/ °C (typ.) for on-chip reference voltage. Automatically temperature compensated.
- Single-point calibration on each phase over the whole dynamic range for active energy; no calibration needed for reactive/ apparent energy.
- $\pm 1$  °C (typ.) temperature sensor accuracy.
- Flexible piece-wise non-linearity compensation: three current (RMS value)-based segments with two programmable thresholds for each phase. Independent gain and phase angle compensation for each segment.
- Electrical parameters measurement: less than  $\pm 0.5\%$  fiducial error for  $V_{rms}$ ,  $I_{rms}$ , mean active/ reactive/ apparent power, frequency, power factor and phase angle.
- Active (forward/reverse), reactive (forward/reverse), apparent energy with independent energy registers.
- Programmable startup and no-load power thresholds.
- 6 dedicated ADCs for phase A/B/C current and voltage sampling circuits. Current sampled over Current Transformer (CT) or

Rogowski coil (di/dt coil); voltage sampled over resistor divider network.

- Programmable power modes: Normal, Idle, Detection and Partial Measurement mode.
- Fundamental (0.2%) and harmonic (1%) active energy with dedicated energy / power registers and independent energy outputs.
- Current and voltage instantaneous signal monitoring.
- Enhanced event detection: sag, over voltage, phase loss, over current, reverse V/I phase sequence, calculated neutral line current  $I_{NC}$  over-current and frequency upper and lower threshold.

### Other Features

- 3.3V single power supply. Operating voltage range: 2.8V~3.6V. Metering accuracy guaranteed within 3.0V~3.6V.
- Four-wire SPI interface.
- Programmable voltage sag detection and zero-crossing output.
- Crystal oscillator frequency: 16.384MHz. On-chip two capacitors and no need of external capacitors.
- Lower power consumption.  $I=13mA$  (typ.) in Normal mode.
- TQFP48 package.
- Operating temperature:  $-40$  °C ~  $+85$  °C .

## APPLICATION

- Poly-phase energy meters of class 0.5S and class 1 which are used in three-phase four-wire (3P4W, Y0) or three-phase three-wire (3P3W, Y or  $\Delta$ ) systems.
- Power monitoring instruments which need to measure voltage, current, mean power, etc.

## GENERAL DESCRIPTION

The 90E32AS is a poly-phase high performance wide-dynamic range metering IC. The 90E32AS incorporates 6 independent 2nd order sigma-delta ADCs, which could be employed in three voltage channels (phase A, B and C) and three current channels (phase A, B, C) in a typical three-phase four-wire system.

The 90E32AS has an embedded DSP which executes calculation of active energy, reactive energy, apparent energy, fundamental and harmonic active energy over ADC signal and on-chip reference voltage. The DSP also calculates measurement parameters such as voltage and current RMS value as well as mean active/reactive/apparent power.

A four-wire SPI interface is provided between the 90E32AS and the external microcontroller.

The 90E32AS is suitable for poly-phase multi-function meters which could measure active/reactive/apparent energy and fundamental/harmonic energy either through four independent energy pulse outputs CF1/CF2/CF3/CF4 or through the corresponding registers.

The ADC and auto-temperature compensation technology for reference voltage ensure the 90E32AS's long-term stability over variations in grid and ambient environment conditions.

**BLOCK DIAGRAM**

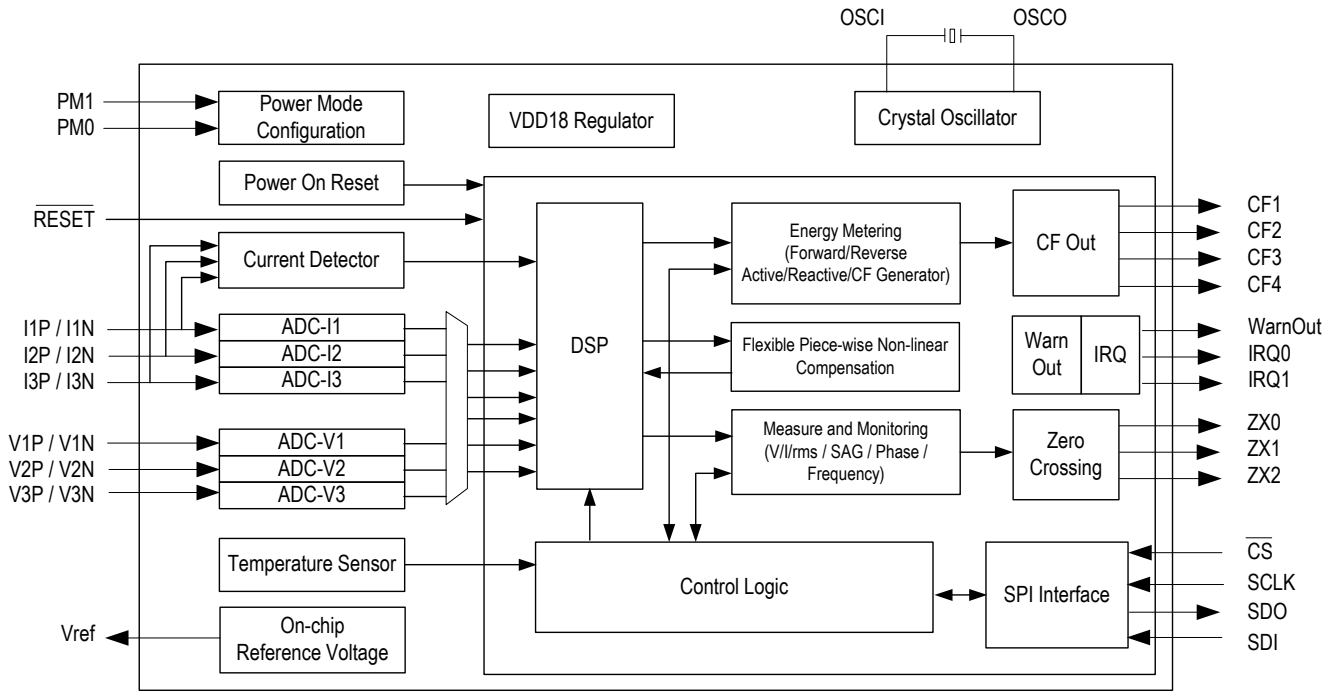

**Figure-1 90E32AS Block Diagram**



# 1 PIN ASSIGNMENT

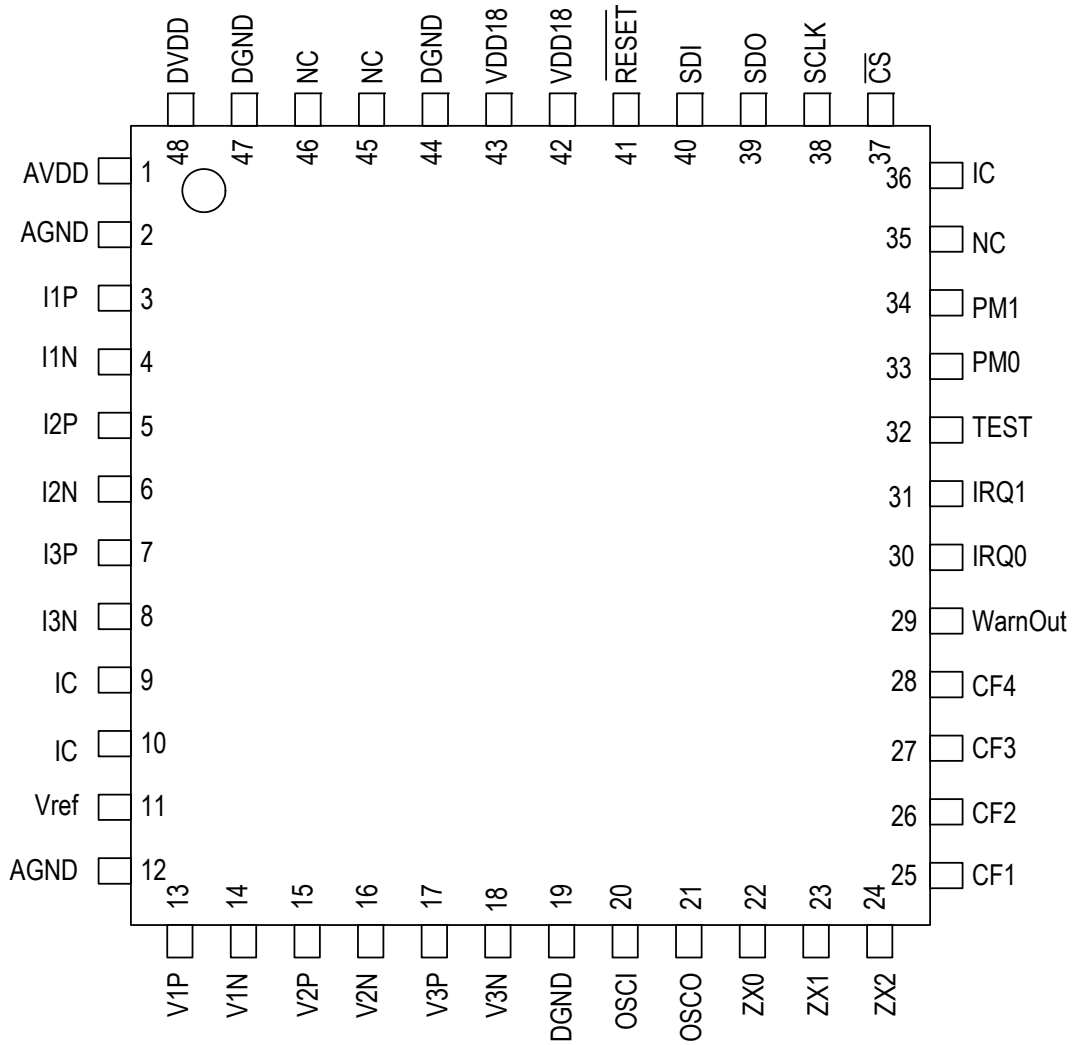

Figure-2 Pin Assignment (Top View)

## 2 PIN DESCRIPTION

Table-1 Pin Description

Name	Pin No.	I/O	Type	Description
$\overline{\text{Reset}}$	41	I	LVTTTL	<b>Reset: Reset Pin (active low)</b> This pin should connect to ground through a 0.1 $\mu\text{F}$ filter capacitor and a 10k $\Omega$ resistor to VDD. In application it can also directly connect to one output pin from microcontroller (MCU).
AVDD	1	I	Power	<b>AVDD: Analog Power Supply</b> This pin provides power supply to the analog part. This pin should connect to DVDD and be decoupled with a 0.1 $\mu\text{F}$ capacitor.
DVDD	48	I	Power	<b>DVDD: Digital Power Supply</b> This pin provides power supply to the digital part. It should be decoupled with a 10 $\mu\text{F}$ capacitor and a 0.1 $\mu\text{F}$ capacitor.
VDD18	42, 43	P	Power	<b>VDD18: Digital Power Supply (1.8 V)</b> These two pins should be connected together and connected to ground through a 10 $\mu\text{F}$ capacitor.
DGND	19, 44, 47	I	Power	<b>DGND: Digital Ground</b>
AGND	2, 12	I	Power	<b>AGND: Analog Ground</b>
I1P I1N	3 4	I	Analog	<b>I1P: Positive Input for Analog ADC Channel</b> <b>I1N: Negative Input for Analog ADC Channel</b> These pins are differential inputs for analog ADC channel. These 6 analog ADC channels can be flexibly mapped, refer to <a href="#">3.4 Analog/digital Channel Mapping</a> . <sup>1</sup>
I2P I2N	5 6	I	Analog	<b>I2P: Positive Input for Analog ADC Channel</b> <b>I2N: Negative Input for Analog ADC Channel</b> These pins are differential inputs for analog ADC channel. These 6 analog ADC channels can be flexibly mapped, refer to <a href="#">3.4 Analog/digital Channel Mapping</a> . <sup>1</sup>
I3P I3N	7 8	I	Analog	<b>I3P: Positive Input for Analog ADC Channel</b> <b>I3N: Negative Input for Analog ADC Channel</b> These pins are differential inputs for analog ADC channel. These 6 analog ADC channels can be flexibly mapped, refer to <a href="#">3.4 Analog/digital Channel Mapping</a> . <sup>1</sup>
Vref	11	O	Analog	<b>Vref: Output Pin for Reference Voltage</b> This pin should be decoupled with a 4.7 $\mu\text{F}$ capacitor, it is better to add a 0.1 $\mu\text{F}$ ceramic capacitor.
V1P V1N	13 14	I	Analog	<b>V1P: Positive Input for Analog ADC Channel</b> <b>V1N: Negative Input for Analog ADC Channel</b> These pins are differential inputs for analog ADC channel. These 6 analog ADC channels can be flexibly mapped, refer to <a href="#">3.4 Analog/digital Channel Mapping</a> . <sup>1</sup>
V2P V2N	15 16	I	Analog	<b>V2P: Positive Input for Analog ADC Channel</b> <b>V2N: Negative Input for Analog ADC Channel</b> These pins are differential inputs for analog ADC channel. These 6 analog ADC channels can be flexibly mapped, refer to <a href="#">3.4 Analog/digital Channel Mapping</a> . <sup>1</sup>
V3P V3N	17 18	I	Analog	<b>V3P: Positive Input for Analog ADC Channel</b> <b>V3N: Negative Input for Analog ADC Channel</b> These pins are differential inputs for analog ADC channel. These 6 analog ADC channels can be flexibly mapped, refer to <a href="#">3.4 Analog/digital Channel Mapping</a> . <sup>1</sup>

Table-1 Pin Description (Continued)

Name	Pin No.	I/O	Type	Description
OSCI	20	I	OSC	<b>OSCI: External Crystal Input</b>
OSCO	21	O	OSC	<b>OSCO: External Crystal Output</b> A 16.384 MHz crystal is connected between OSCI and OSCO. There are two on-chip capacitors, therefore no need of external capacitors.
ZX0 ZX1 ZX2	22 23 24	O	LVTTL	<b>ZX2/ZX1/ZX0: Zero-Crossing Output</b> These pins are asserted when voltage or current crosses zero. Zero-crossing mode can be configured by the <a href="#">ZXConfig</a> register (07H).
CF1	25	O	LVTTL	<b>CF1: (all-phase-sum total) Active Energy Pulse Output</b>
CF2	26	O	LVTTL	<b>CF2: (all-phase-sum total) Reactive/ Apparent Energy Pulse Output</b> The output of this pin is determined by the CF2varh bit (b7, <a href="#">MMode0</a> ).
CF3	27	O	LVTTL	<b>CF3: (all-phase-sum total) Active Fundamental Energy Pulse Output</b>
CF4	28	O	LVTTL	<b>CF4: (all-phase-sum total) Active Harmonic Energy Pulse Output</b>
WarnOut	29	O	LVTTL	<b>WarnOut: Fatal Error Warning</b> This pin is asserted high when there is metering related parameter checksum error. Otherwise this pin stays low. Refer to <a href="#">5.2.2 IRQ and WarnOut Signal Generation</a> .
IRQ0	30	O	LVTTL	<b>IRQ0: Interrupt Output 0</b> This pin is asserted when one or more events in the <a href="#">EMMIntState0</a> register (1CCH) occur. It is deasserted when there is no bit set in the <a href="#">EMMIntState0</a> register (1CCH). In Detection mode, the IRQ0 is used to indicate the output of current detector. The IRQ0 state is cleared when entering or exiting Detection mode.
IRQ1	31	O	LVTTL	<b>IRQ1: Interrupt Output 1</b> This pin is asserted when one or more events in the <a href="#">EMMIntState1</a> register (1D0H) occur. It is deasserted when there is no bit set in the <a href="#">EMMIntState1</a> register (1D0H). In Detection mode, the IRQ1 is used to indicate the output of current detector. The IRQ1 state is cleared when entering or exiting Detection mode.
PM0 PM1	33 34	I <sup>2</sup>	LVTTL	<b>PM1/0: Power Mode Configuration</b> These two pins define the power mode of 90E32AS. Refer to <a href="#">Table-2</a> .
$\overline{\text{CS}}$	37	I <sup>2</sup>	LVTTL	<b>CS: Chip Select (Active Low)</b> In SPI mode, this pin must be driven from high to low for each read/ write operation, and maintain low for the entire operation.
SCLK	38	I <sup>2</sup>	LVTTL	<b>SCLK: Serial Clock</b> This pin is used as the clock for the SPI interface. Refer to <a href="#">4 SPI Interface</a> .
SDO	39	O	LVTTL	<b>SDO: Serial Data Output</b> This pin is used as the data output for the SPI mode. Refer to <a href="#">4 SPI Interface</a> .
SDI	40	I <sup>2</sup>	LVTTL	<b>SDI: Serial Data Input</b> This pin is used as the data input for the SPI mode. Refer to <a href="#">4 SPI Interface</a> .
TEST	32	I	LVTTL	This pin should be always connected to DGND in system application.
IC	9, 10, 36		LVTTL	These pins should be always connected to DGND in system application.
NC	35, 45, 46			<b>NC: These pins should be left open.</b>

Note 1: The channel mapping is only valid in Normal mode and Patial Measurement mode.  
Note 2: All the digital input pins except OSCI are 5 V compatible.

## 3 FUNCTION DESCRIPTION

### 3.1 POWER SUPPLY

The 90E32AS works with single power rail 3.3V. An on-chip voltage regulator regulates the 1.8V voltage for the digital logic.

The regulated 1.8V power is connected to the VDD18 pin. It needs to be bypassed by an external capacitor.

The 90E32AS has four power modes: Normal (N mode), Partial Measurement (M mode), Detection (D mode) and Idle (I mode). In Idle and Detection modes the 1.8V power regulator is not turned on and the digital logic is not powered. When the logic is not powered, all the configured register values are not kept (all context lost) except for Detection mode related registers (10H~13H) for Detection mode configuration.

The registers in Partial Measurement mode or Normal mode have to be re-configured when transiting from Idle or Detection mode. Refer to [3.8 Power Mode](#) for power mode details.

### 3.2 CLOCK

The 90E32AS has an on-chip oscillator and can directly connect to an external crystal.

The OSC1 pin can also be driven with a clock source.

The oscillator will be powered down in Idle and Detection power modes, as described in [3.8 Power Mode](#).

### 3.3 RESET

There are three reset sources for the 90E32AS:

- $\overline{\text{RESET}}$  pin
- On-chip Power On Reset circuit
- Software Reset generated by the [SoftReset](#) register

#### 3.3.1 $\overline{\text{RESET}}$ PIN

The  $\overline{\text{RESET}}$  pin can be asserted to reset the 90E32AS. The  $\overline{\text{RESET}}$  pin has RC filter with typical time constant of 2 $\mu$ s in the I/O, as well as a 2 $\mu$ s (typical) de-glitch filter.

Any reset pulse that is shorter than 2 $\mu$ s can not reset the 90E32AS.

#### 3.3.2 POWER ON RESET (POR)

The POR circuit resets the 90E32AS at power up.

POR circuit triggers reset when:

- DVDD power up with crossing the power-up threshold. Refer to [Figure-24](#).
- VDD18 regulator changing from disable to enable, i.e. from Idle or Detection mode to Partial Measurement mode or Normal mode. Refer to [Figure-23](#).

#### 3.3.3 SOFTWARE RESET

Chip reset can be triggered by writing to the [SoftReset](#) register in Normal mode. The software reset is the same as the reset scope generated from the  $\overline{\text{RESET}}$  pin or POR.

These three reset sources have the same reset scope.

All digital logics and registers except for some special registers will be subjected to reset.

- Interface logic: clock dividers
- Digital core/ logic: All registers except for some special registers. Refer to [5.3.1 Detection Mode Registers](#).

### 3.4 ANALOG/DIGITAL CHANNEL MAPPING

Analog channel to digital channel mapping:

The 6 analog ADC channels can be flexibly mapped to the 6 digital metering/measuring channels (V/I phase A/B/C). Refer to the [ChannelMapI](#) and [ChannelMapU](#) registers for configuration.

Note that channel mapping is only valid in Normal mode and Partial Measurement mode.

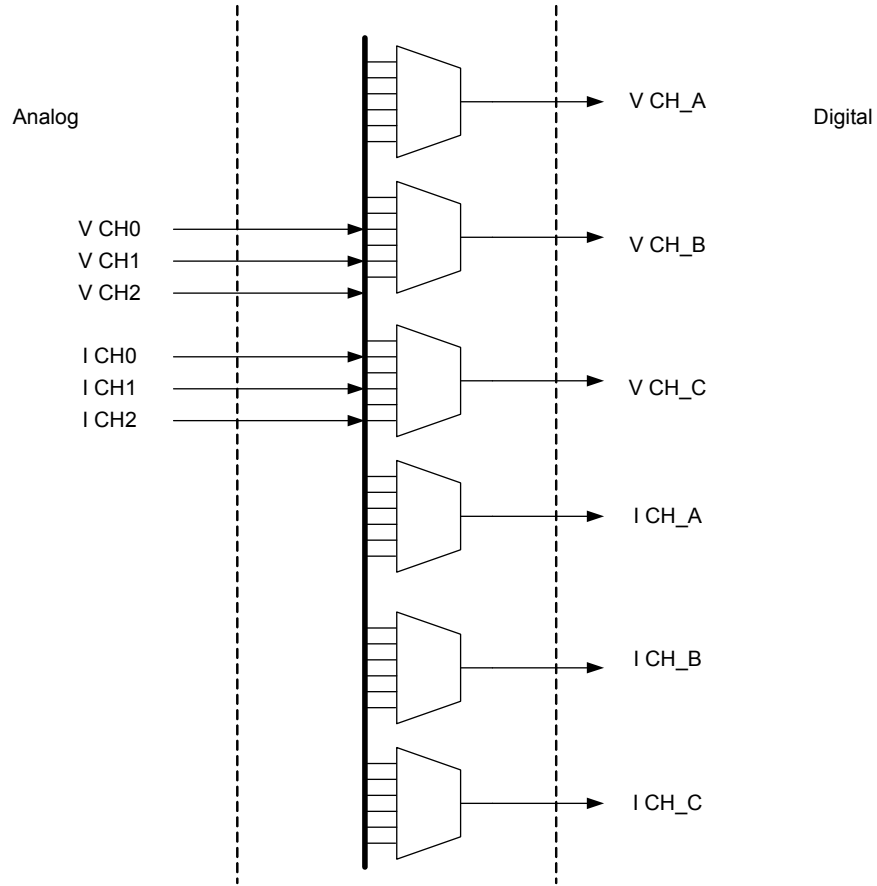

Flexible Channel mapping

**Figure-3 Channel to Phase Mapping**

### 3.5 METERING FUNCTION

Metering is enabled when any of the [MeterEn](#) bits are set.

When metering is not enabled, the CF pulse will not be generated and energy accumulator will not accumulate energy. All energy accumulation related status will be cleared, while startup/noload handling block related status will be still working.

The accumulated energy will be converted to pulse frequency on the CF pins and stored in the corresponding energy registers.

#### 3.5.1 THEORY OF ENERGY REGISTERS

The energy accumulation runs at 1 MHz clock rate by accumulating the power value calculated by the DSP processor.

The power accumulation process is equivalent to digitally integrating the instantaneous power with a delta-time of about 1 $\mu$ s. The accumulated energy is used to calculate the CF pulses and the corresponding internal energy registers.

The accumulated energy is converted to frequency of the CF pulses. One CF usually corresponds to 1KWh / MC (MC is Meter Constant, e.g.

3200 imp/kWh), and is usually referenced as an energy unit in this data-sheet. The internal energy resolution for accumulation and conversion is 0.01 CF.

The 0.01 CF pulse energy constant is referenced as 'PL\_constant'.

Within 0.01 CF, forward and reverse energy are counteracted. When energy exceeds 0.01 pulse, the respective forward/ reverse energy is increased.

Take the example of active energy. Suppose:

T0: Forward energy register is 12.34 pulses and reverse energy register is 1.23 pulses.

From t0 to t1: 0.005 forward pulses appeared.

From t1 to t2: 0.004 reverse pulses appeared.

From t2 to t3: 0.005 reverse pulses appeared.

From t3 to t4: 0.007 reverse pulses appeared.

The following table illustrates the process of energy accumulation process:

	t0	t1	t2	t3	t4
<b>Input energy</b>	+ 0.005	-0.004	-0.005	-0.007	
<b>Bidirectional energy accumulator</b>	0.005	0.001	-0.004	-0.001	
<b>Forward 0.01 CF</b>	0	0	0	0	
<b>Reverse 0.01CF</b>	0	0	0	1	
<b>Forward energy register</b>	12.34	12.34	12.34	12.34	12.34
<b>Reverse energy register</b>	1.23	1.23	1.23	1.23	1.24

When forward/reverse energy reaches 0.01 pulse, the respective register is updated. When forward or reverse energy reaches 1 pulse,

CFx pins output pulse and the CFxRevST bits (b3-0, [EMMState0](#)) are updated. Refer to [Figure-4](#).

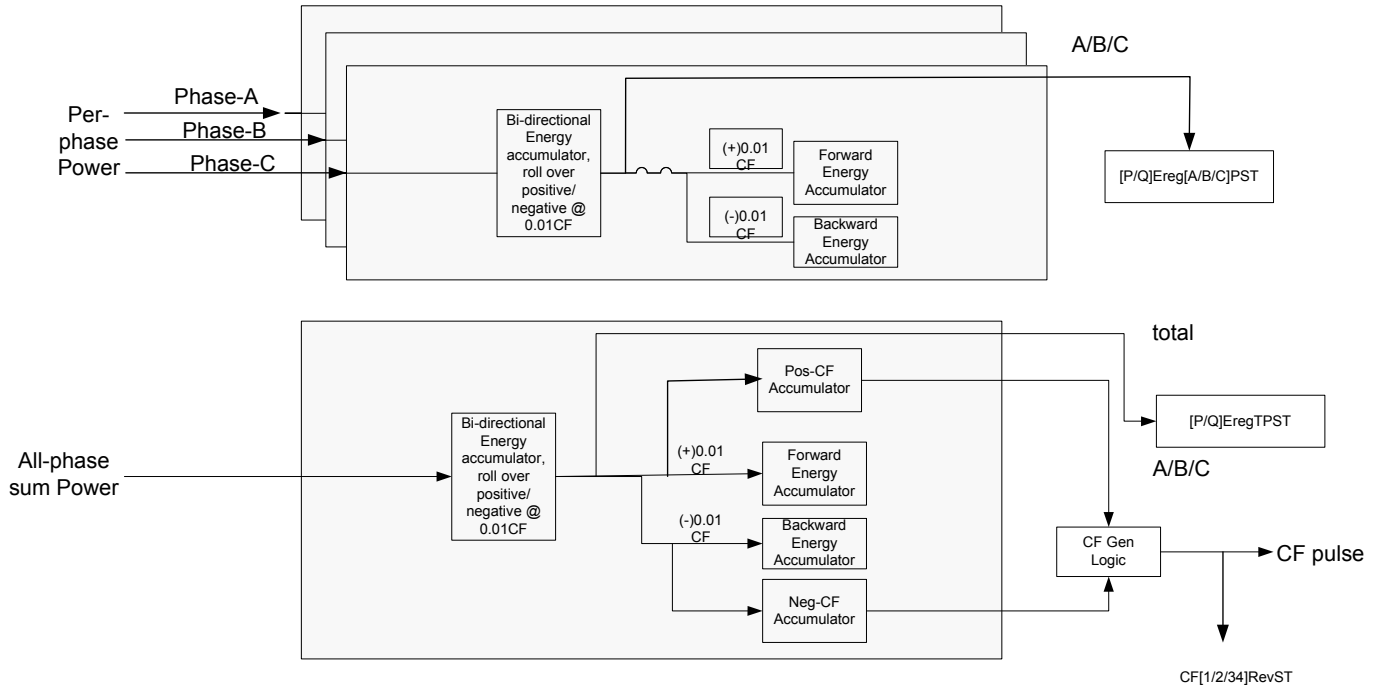

**Figure-4 Energy Accumulation Diagram**

For all-phase-sum total of active, reactive and (arithmetic sum) apparent energy, the associated power is obtained by summing the power of the three phases. The accumulation method of all-phase-sum

energy is determined by the EnPC/EnPB/EnPA/ABSEnP/ABSEnQ bits (b0~b4, *MMode0*).

Note that the direction of all-phase-sum power and single-phase power might be different.

### 3.5.2 ENERGY REGISTERS

The 90E32AS meters non-decomposed total active, reactive and apparent energy, as well as decomposed active fundamental and harmonic energy. The registers are listed as below.

#### 3.5.2.1 Total Energy Registers

Each phase and all-phase-sum has the following registers:

- Active forward/ reverse
- Reactive forward/ reverse
- Apparent energy

Altogether there are 20 energy registers. Those registers are defined in [5.5.1 Regular Energy Registers](#).

#### 3.5.2.2 Fundamental and Harmonic Energy Registers

The 90E32AS counts decomposed active fundamental and harmonic energy. Reactive energy is not decomposed to fundamental and harmonic.

The fundamental/harmonic energy is accumulated in the same way as active energy accumulation method described above.

Registers:

- Fundamental / harmonic
- all-phase-sum / phase A / phase B / phase C
- Forward / reverse

Altogether there are 16 energy registers. Refer to [5.5.2 Fundamental / Harmonic Energy Register](#).

### 3.5.3 ENERGY PULSE OUTPUT

CF1 is fixed to be total active energy output (all-phase-sum). Both forward and reverse energy registers can generate the CF pulse (change of forward/ reverse direction can generate an interrupt if enabled).

CF2 is reactive energy output (all-phase-sum) by default. It can also be configured to be arithmetic sum apparent energy output (all-phase-sum).

CF3 is fixed to be active fundamental energy output (all-phase-sum).

CF4 is fixed to be active harmonic energy output (all-phase-sum).

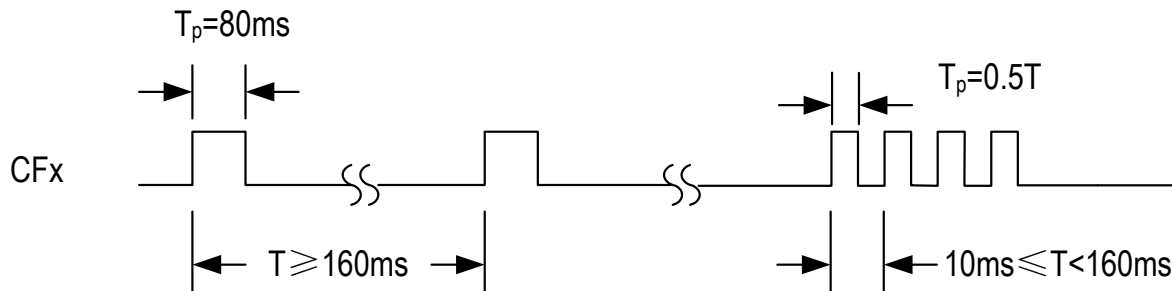

**Figure-5 CFx Pulse Output Regulation**

For CFx pulse width regulation, refer to [Figure-5](#).

Case1  $T \geq 160\text{ms}$ ,  $T_p = 80\text{ms}$

Case 2  $10\text{ms} \leq T < 160\text{ms}$ ,  $T_p = T/2$



3.5.4 STARTUP AND NO-LOAD POWER

There are startup power threshold registers (e.g. PStartTh(35H)). Refer to 5.4 Configuration and Calibration Registers. The power threshold registers are defined for all-phase-sum active, reactive and apparent power. The 90E32AS starts metering when the corresponding all-phase-sum power is greater than the startup threshold. When the power value is lower than the startup threshold, energy is not accumulated and it is assumed as in no-load status. Refer to Figure-6.

There are also no-load Current Threshold registers for Active, Reactive and Apparent energy metering participation for each of the 3 phases. If  $|P|+|Q|$  is lower than the corresponding power threshold, that particular phase will not be accumulated. Refer to the PStartTh register and other threshold registers.

There are also no-load status bits (the TPnoload/TQnoload bits (b14~15, Fundamental / Harmonic Energy Register)) defined to reflect the no-load status. The 90E32AS does not output any pulse in no-load status. The power-on state is of no-load status.

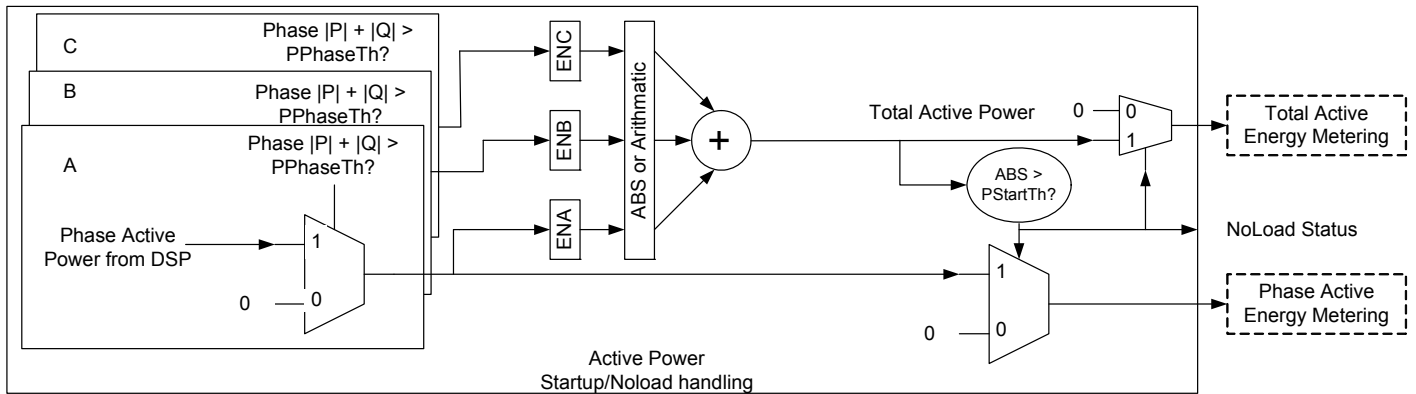

Figure-6 Active Power Startup/No-load Processing

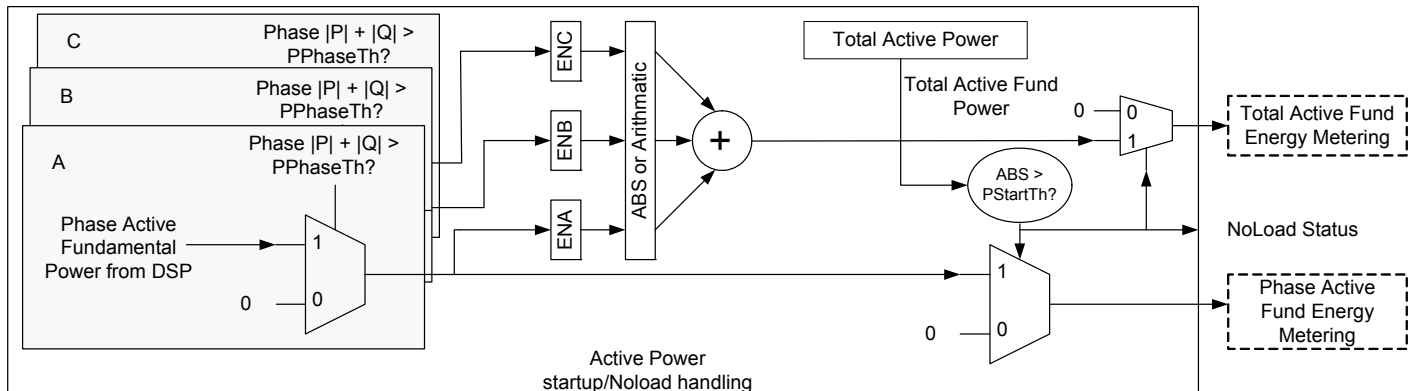

Figure-7 Fundamental Active Power Startup/No-load Processing

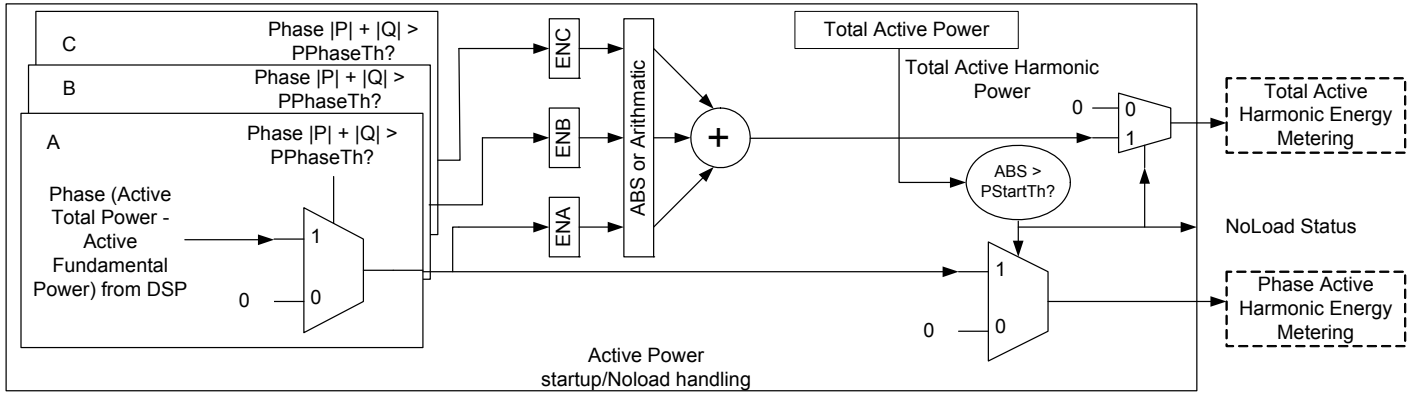

Figure-8 Harmonic Active Power Startup/No-load Processing

### 3.6 MEASUREMENT FUNCTION

Measured parameters can be divided to 8 types as follows:

- Active/ Reactive/ Apparent Power
- Fundamental/ Harmonic Power
- RMS for Voltage and Current
- Power Factor
- Phase Angle
- Frequency
- Temperature
- Peak Value

Measured parameters are average values that are averaged among 16 phase-voltage cycles (about 320ms at 50Hz) except for the temperature. The measured parameter update frequency is approximately 3Hz. Refer to [Table-17](#).

#### 3.6.1 ACTIVE/ REACTIVE/ APPARENT POWER

Active/ Reactive/ Apparent Power measurement registers can be divided as below:

- active, reactive, apparent power
- all-phase-sum / phase A / phase B / phase C

Altogether there are 12 power registers. Refer to [5.6.1 Power and Power Factor Registers](#).

Per-phase apparent power is defined as the product of measured  $V_{rms}$  and  $I_{rms}$  of that phase.

All-phase-sum power is measured by arithmetically summing the per-phase measured power. The summing of phases can be configured by the [MMode0](#) register.

#### 3.6.2 FUNDAMENTAL / HARMONIC ACTIVE POWER

Fundamental / harmonic active power measurement registers can be divided as below:

- fundamental and harmonic power
- all-phase-sum / phase A / phase B / phase C

Altogether there are 8 power registers. Refer to [5.6.2 Fundamental/ Harmonic Power and Voltage/ Current RMS Registers](#).

#### 3.6.3 MEAN POWER FACTOR (PF)

Power Factor is defined for those cases: all-phase-sum / phase A / phase B / phase C.

Altogether there are 4 power factor registers. Refer to [5.6.1 Power and Power Factor Registers](#).

For all-phase:

$$PF_{all} = \frac{\text{All\_phase\_sum active\_power}}{\text{All\_phase\_sum apparent\_power}}$$

For each of the phase::

$$PF_{phase} = \frac{\text{active\_power}}{\text{apparent\_power}}$$

#### 3.6.4 VOLTAGE / CURRENT RMS

Voltage/current RMS registers can be divided as follows:

##### Per-phase: Phase A / Phase B / Phase C

Voltage / Current

##### Neutral Line Current RMS:

Neutral line current can be calculated by instantaneous value

$$i_N = i_A + i_B + i_C .$$

Altogether there are 7 RMS registers.

Refer to [5.6.2 Fundamental/ Harmonic Power and Voltage/ Current RMS Registers](#).

### 3.6.5 PHASE ANGLE

Phase Angle measurement registers can be divided as below:

- phase A / phase B / phase C
- voltage / current

Altogether there are 6 phase angle registers. Refer to [5.6.3 Peak, Frequency, Angle and Temperature Registers](#).

Phase Angle is measured by the time-difference between the Voltage and Current channel of the same phase.

### 3.6.6 FREQUENCY

The frequency is measured basing on the zero-crossing point of voltage channels.

The phase A voltage signal zero-crossing will be used to compute the frequency. If phase A is in the SAG condition, phase C will be used. If phase C is also in SAG condition, phase B will be used.

If all the phases are in the SAG condition, Frequency will be measured based on the channels which are not in phaseLoss condition (with the same order). If all phases are lost, the frequency will return zero.

The frequency data is not averaged (updated cycle by cycle).

Refer to [5.6.3 Peak, Frequency, Angle and Temperature Registers](#).

### 3.6.7 TEMPERATURE

Chip Junction-Temperature is measured roughly every 100 ms by on-chip temperature sensor.

Refer to [5.6.3 Peak, Frequency, Angle and Temperature Registers](#).

### 3.6.8 PEAK VALUE

Altogether there are 6 peak value registers. Refer to [5.6.3 Peak, Frequency, Angle and Temperature Registers](#).

Refer to [3.7.1 Instantaneous Signal Monitoring](#).

### 3.7 POWER QUALITY MONITORING

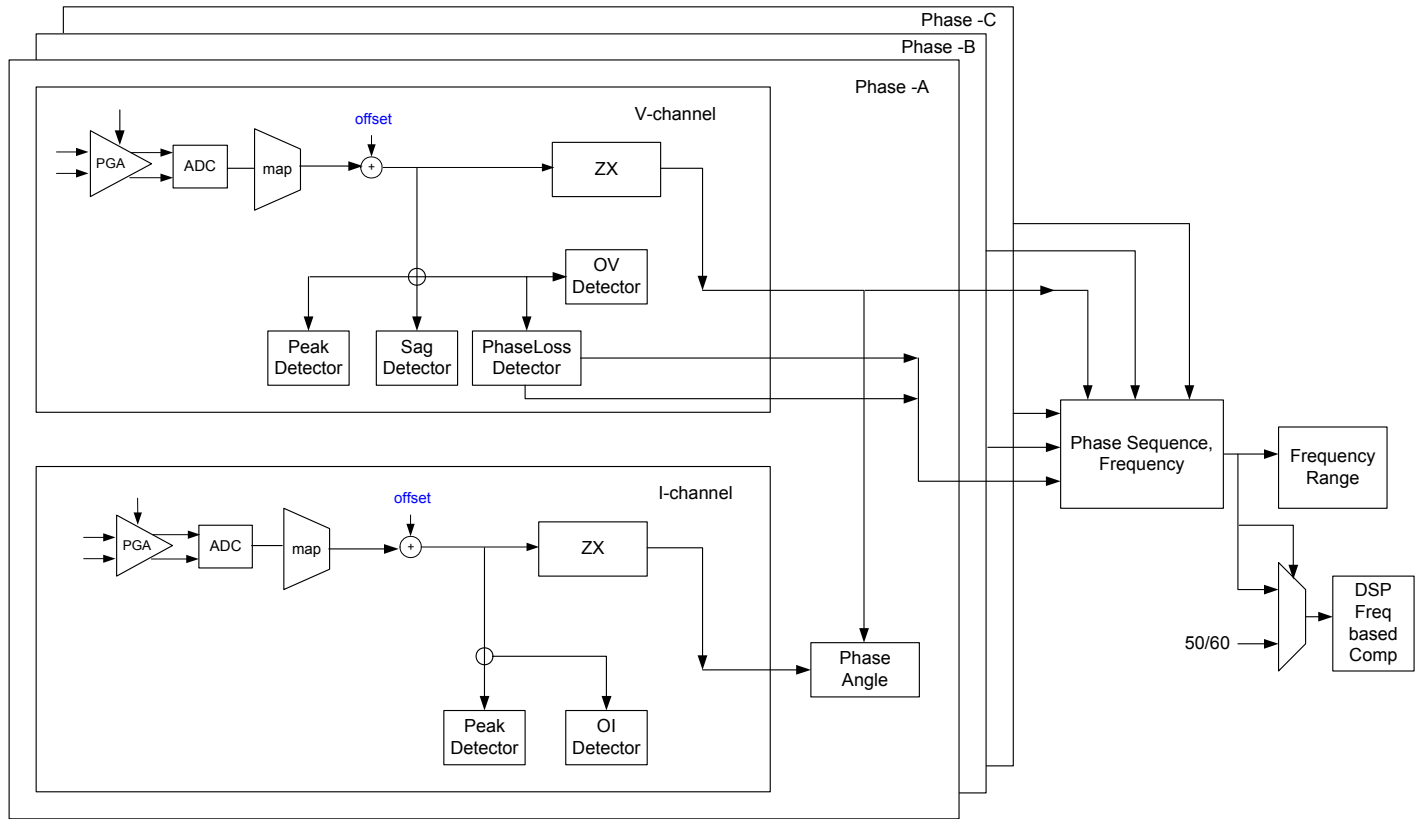

**Figure-9 Power Quality Monitor in Datapath**

#### 3.7.1 INSTANTANEOUS SIGNAL MONITORING

Peak detection function:

Peak value for each channel was detected within timing period configured by the PeakDet\_period bits (b15~8, SagPeakDetCfg).

The detected peak value is updated on period intersection.

Registers:

The peak value detected can be accessed through register U/I Peak registers. Refer to 5.6.3 Peak, Frequency, Angle and Temperature Registers.

#### 3.7.2 INSTANTANEOUS SIGNAL RELATED STATUS AND EVENTS

The registers involved are OVth, Olth, SagTh, PhaseLossTh and SagPeakDetCfg.

The result can be reflected in EMMState0 and EMMState1 registers, as well as EMMIntState0 and EMMIntState1 registers if the corresponding bits in EMMIntEn0/EMMIntEn1 registers are set.

The threshold value has the following relationship with the RMS register (MSB-16bit):

$$xxThRegValue = \frac{RmsRegValue * \sqrt{2}}{Vlgain / 2^{14}}$$

Here Vlgain is Ugain register value or Igain register value.

### 3.7.2.1 Sag Detection

Usually in the application the Sag threshold is set to be 78% of the reference voltage. The 90E32AS generates Sag event when there are less than three 8KHz samples (absolute value) greater than the sag threshold in one detecting period. Refer to [6.6 Voltage Sag and Phase Loss Timing](#). The detecting period length can be configured by the Sag\_Period bits (b7~0, [SagPeakDetCfg](#)).

Sag status is asserted when there is no voltage instantaneous sample's absolute value goes beyond the Sag threshold in any phase. Sag status is cleared when there are three samples detected with absolute value above the Sag threshold.

For the computation of Sag threshold register value, refer to AN-644.

The Sag event is captured by the SagPhaseIntST bits (b14-12, [EMMIntState1](#)). If the corresponding IRQ enable bits the SagPhaseIntEN bits (b14-12, [EMMIntEn1](#)) is set, IRQ can be generated. Refer to [Figure-26](#).

### 3.7.2.2 Phase Loss Detection

The phase loss detection detects if there is one or more phases' voltage is less than the phase-loss threshold voltage.

The processing and handling is similar to sag detection, only the threshold is different. The threshold computation flow is also similar. The typical threshold setting could be 10% Un or less.

If any phase line is detected as in phase-loss mode, that phase's zero-crossing detection function (both voltage and current) is disabled.

### 3.7.2.3 Over Voltage (OV) Detection

When any phase's absolute voltage sample instantaneous value goes beyond the over voltage threshold, the Over Voltage status is asserted. The status is de-asserted when the voltage sample instantaneous value go back below the over voltage threshold.

Change of the Over Voltage status can generate interrupt and flagged in the [EMMState0](#) and [EMMIntState0](#) registers.

### 3.7.2.4 Over Current (OI) Detection

When any phase's absolute current sample instantaneous value go beyond the over current threshold, the Over Current status is asserted. The status is de-asserted when the current sample instantaneous value go back below the over current threshold.

Change of the Over Current status can generate interrupt and flagged in the [EMMState0](#) and [EMMIntState0](#) registers.

### 3.7.3 FREQUENCY MONITORING RELATED STATUS AND EVENTS

The measured frequency is compared with two thresholds configured in the the [FreqLoTh](#) register and the [FreqHiTh](#) register.

If the measured frequency goes beyond the range defined by the two thresholds, the FreqLoST bit (b11, [EMMState1](#)) and FreqHiST bit (b15, [EMMState1](#)) will be asserted.

The interrupt status will be updated as well; and if enabled, interrupt signal can be asserted.

### 3.7.4 ZERO-CROSSING DETECTION

Zero-crossing detector detects the zero-crossing point of the fundamental component of voltage and current for each of the 3 phases. Refer to [6.5 Zero-Crossing Timing](#).

Zero-crossing signal can be independently configured and output. Refer to the definition of the [ZXConfig](#) register.

### 3.7.5 NEUTRAL LINE OVERCURRENT DETECTION

The neutral line rms current (calculated)  $I_{NC}$  is checked with the threshold defined in the [InWarnTh](#) register. If the N Line current is greater than the threshold, the INOV0ST bit (b7, [EMMState0](#)) is set. IRQ0 is generated if the INOV0IntEN bit (b7, [EMMIntEn0](#)) is set.

### 3.7.6 PHASE SEQUENCE ERROR DETECTION

The phase sequence is detected in two cases: 3P4W and 3P3W, which is defined by the 3P3W bit (b8, [MMMode0](#)).

#### 3P4W case:

Correct sequence: Voltage/current zero-crossing sequence: phase-A, phase-B and phase-C.

#### 3P3W case:

Correct sequence: Voltage/current zero-crossing between phase-A and phase-C is greater than 180 degree.

If the above mentioned criteria are violated, it is assumed as a phase sequence error, the URevWnST bit (b9, [EMMState0](#)) or the IRevWnST bit (b9, [EMMState0](#)) will be set.

### 3.8 POWER MODE

The 90E32AS has four power modes. The power mode is solely defined by the PM1 and PM0 pins.

**Table-2 Power Mode Mapping**

PM1:PM0 Value	Power Mode
11	Normal (N mode)
10	Partial Measurement (M mode)
01	Detection (D mode)
00	Idle (I mode)

#### 3.8.1 NORMAL MODE (N MODE)

In Normal mode, the default is that all function blocks are active except for current detector block. Refer to [Figure-10](#).

The current detector can be enabled and calibrated in normal mode using control bits in [DetectCtrl](#) register.

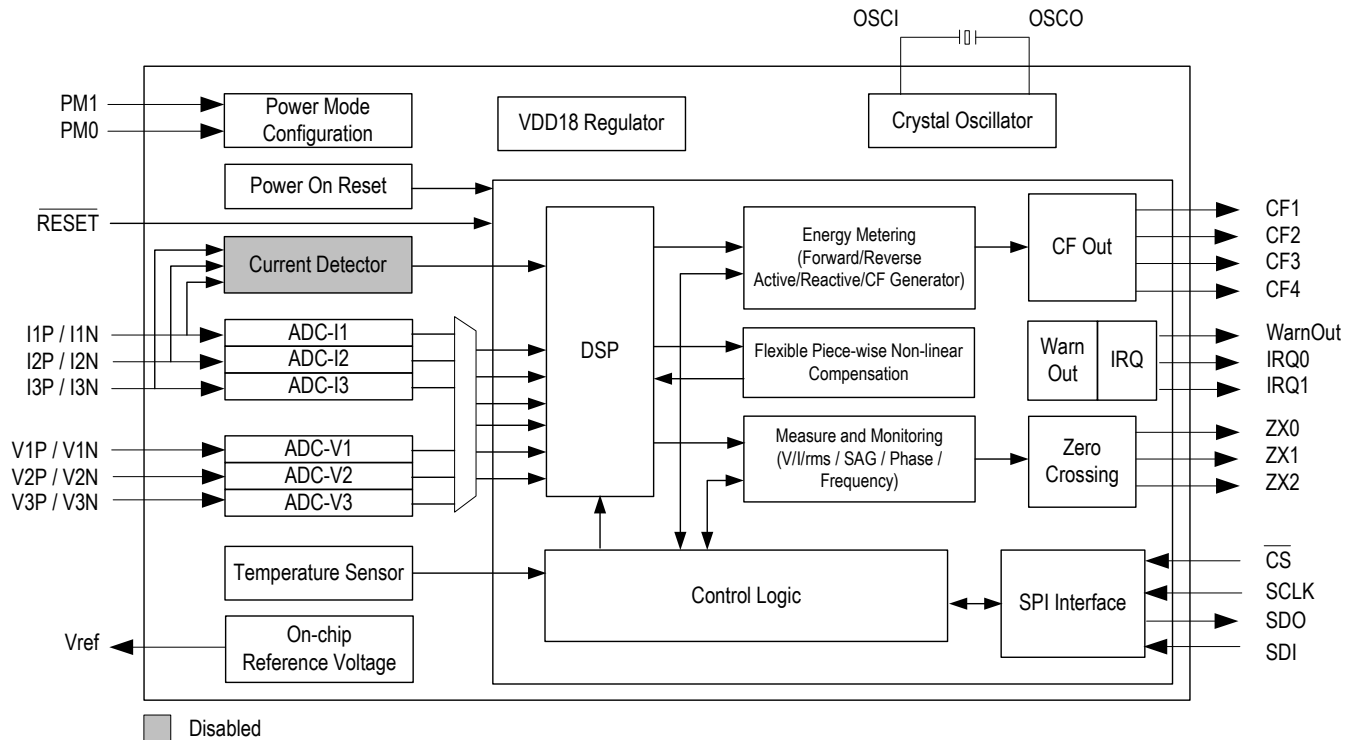

**Figure-10 Block Diagram in Normal Mode**

**3.8.2 IDLE MODE (I MODE)**

In Idle mode, all functions are shut off.

The analog blocks' power supply is powered but circuits are set into power-down mode, i.e. power supply applied but all current paths are shut off. There is very low current since only very low device leakage could exist in this mode.

The digital I/Os' supply is powered.

In I/O and analog interface, the input signals from digital core (which is not powered) will be set to known state as described in Table-3. The PM1 and PM0 pins which are controlled by external MCU are active and can configure the 90E32AS to other modes.

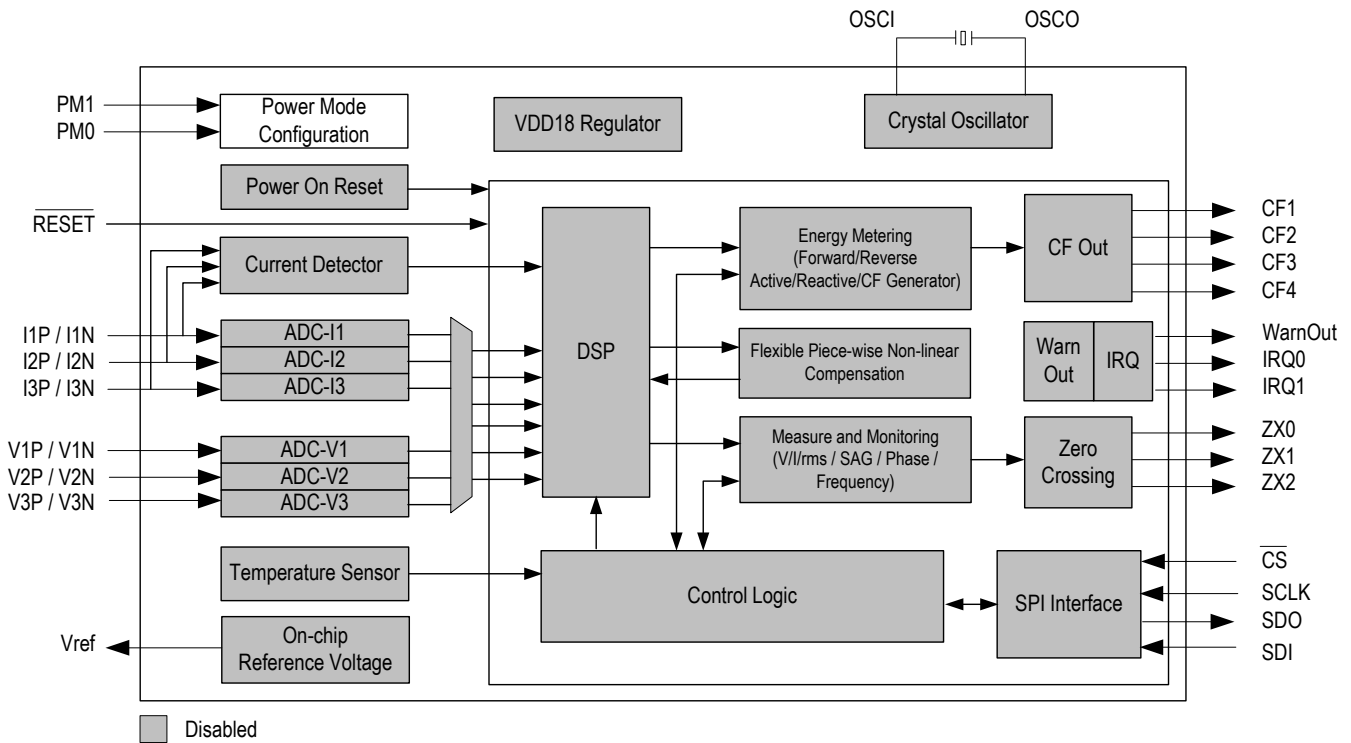

**Figure-11 Block Diagram in Idle Mode**

Please note that since the digital I/O is not shut off, the I/O circuit is active in the Idle mode. The application shall make sure that valid logic levels are applied to the I/O.

Table-3 lists digital I/O and power pins' states in Idle mode. It lists the requirements for inputs and the output level for output.

**Table-3 Digital I/O and Power Pin States in Idle Mode**

Name	I/O type	Type	Pin State in Idle Mode
Reset	I	LVTTL	Input level shall be VDD33.
CS	I	LVTTL	I/O set in input mode. Input level shall be VDD33 or VSS.
SCLK	I	LVTTL	I/O set in input mode. Input level shall be VDD33 or VSS.
SDO	O	LVTTL	I/O set in input mode. Input level shall be VDD33 or VSS.
SDI	I	LVTTL	I/O set in input mode. Input level shall be VDD33 or VSS.
PM1 PM0	I	LVTTL	As defined in Table-2.
OSCI OSCO	I O	OSC	Oscillator powered down. OSCO stays at fixed (low) level.



Table-3 Digital I/O and Power Pin States in Idle Mode (Continued)

Name	I/O type	Type	Pin State in Idle Mode
ZX0 ZX1 ZX2	0	LVTTTL	0
CF1 CF2 CF3 CF4	0	LVTTTL	0
WarnOut	0	LVTTTL	0
IRQ0 IRQ1	0	LVTTTL	0
VDD18	I	Power	Regulated 1.8V: high impedance
DVDD	I	Power	Digital Power Supply: powered by system
AVDD	I	Power	Analog Power Supply: powered by system
Test	I	Input	Always tie to ground in system application

**3.8.3 DETECTION MODE (D MODE)**

In Detection mode, the current detector is active. The current detector compares whether any phase current exceeds the configured threshold using low-power comparators.

When the current of one phase or multiple phases exceeds the configured threshold, the 90E32AS asserts the IRQ0 pin to high and hold it until power mode change. The IRQ0 state is cleared when entering or exiting Detection mode.

When the current of all three current channels exceed the configured threshold, the 90E32AS asserts the IRQ1 pin to high and hold it until power mode change. The IRQ1 state is cleared when entering or exiting Detection mode.

The threshold registers need to be programmed in Normal mode before entering Detection mode.

The digital I/O state is the same as that in Idle state (except for IRQ0/IRQ1 and PM1/PM0).

The 90E32AS has two comparators for detecting each phase's positive and negative current. Each comparator's threshold can be set individually. The two comparators are both active by default, which called 'double-side detection'. User also can enable one comparator only to save power consumption, which called 'single-side detection'.

Double-side detection has faster response and can detect 'half-wave' current. But it consumes nearly twice as much power as single-side detection.

Comparators can be power-down by configuring the [DetectCtrl](#) register. The current detector can be enabled and calibrated in normal mode using control bits in the [DetectCtrl](#) register.

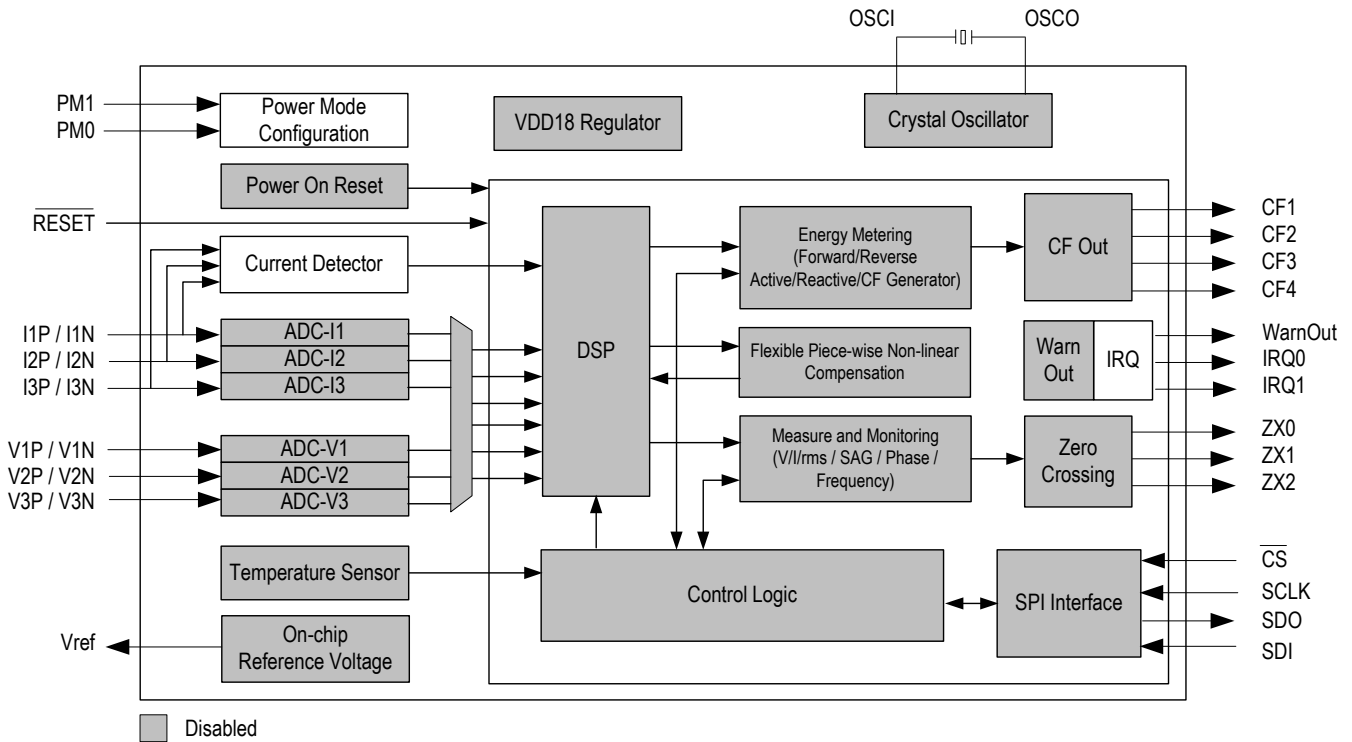

**Figure-12 Block Diagram in Detection Mode**

### 3.8.4 PARTIAL MEASUREMENT MODE (M MODE)

In this mode, all the measurements are through the same hardware that does the measurement in the normal mode. To save power, the energy accumulation block and a portion of the DSP computation code will not be running in this mode.

In this mode, There are configuration bits in the **PMPwrCtrl** register to get lower power if the application allows:

- Option to turn-off the three analog voltage channel if there is no need to measure voltage and power.
- Option to lower down the digital clock from 16.384Mhz to 8.192MHz

In Partial Measurement mode, CRC checking will be disabled. The interrupts will not be generated.

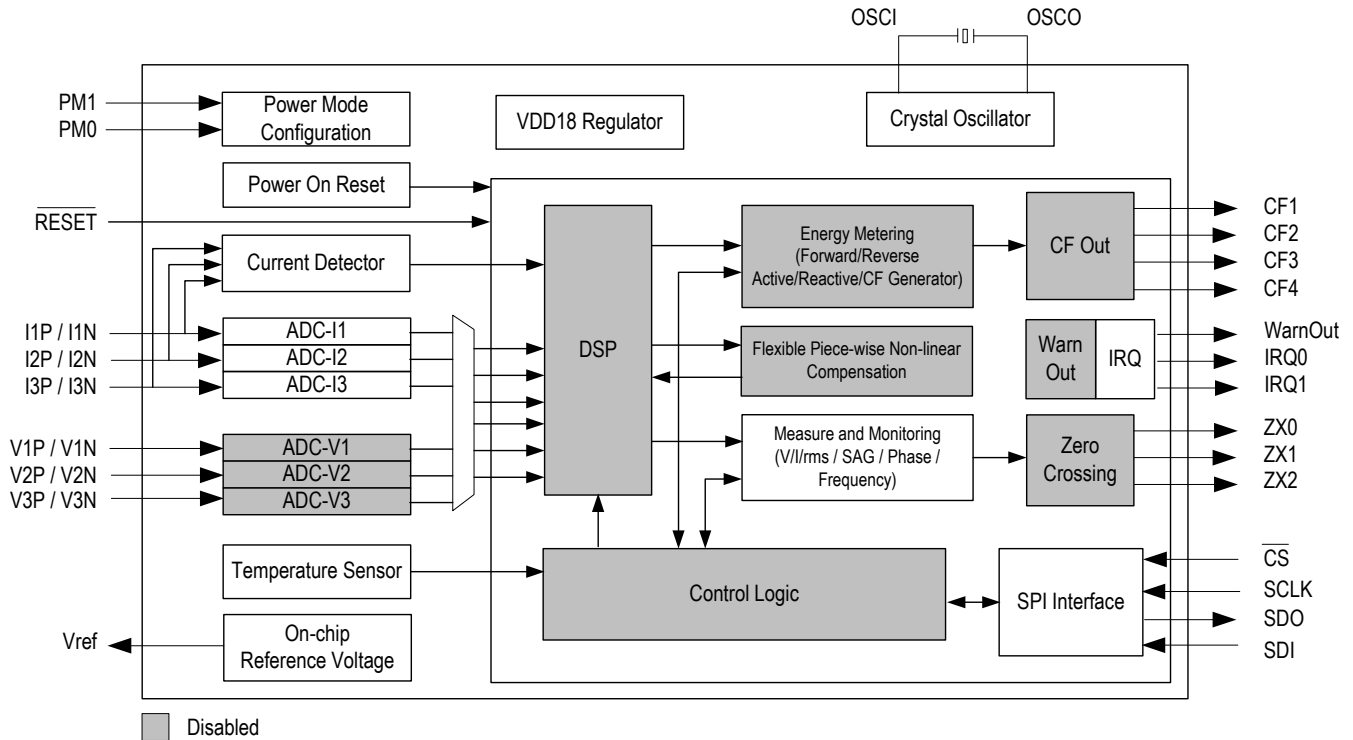

**Figure-13 Block Diagram in Partial Measurement mode**

### 3.8.5 TRANSITION OF POWER MODES

The above power modes are controlled by the PM0 and PM1 pins. In application, the PM0 and PM1 pins are connected to external MCU. The PM0 and PM1 pins have internal RC- filters.

Generally, the 90E32AS stays in Idle mode most of the time while outage. It enters Detection mode at a certain interval (for example 5s) as controlled by the MCU. It informs the MCU if the current exceeds the configured threshold. The MCU then commands the 90E32AS to enter Partial Measurement mode at a certain interval (e.g. 60s) to read related current. After current reading, the 90E32AS gets back to the Idle mode.

The measured current may be used to count energy according to some metering model (like current RMS multiplying the rated voltage to compute the power).

Any power mode transition goes through the Idle mode, as shown in [Figure-14](#).

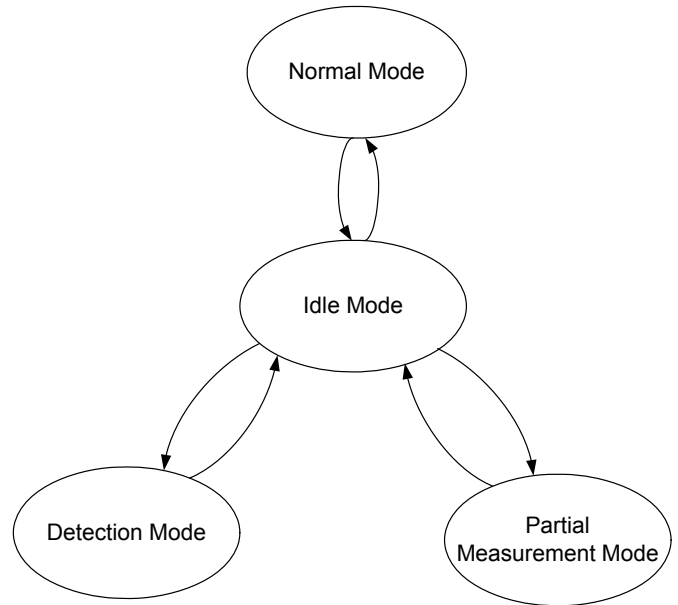

**Figure-14 Power Mode Transition**

### 3.9 EXTERNAL COMPONENT COMPENSATION

The calibrated channel gain and phase-delay offset could be tuned with respect to some reference parameter. This feature is useful when external component is not ideal and allow low cost sensors used in the system.

There are three reference parameters:

- Measured Current RMS (per phase)
- Measured line frequency (all phase in common)
- Measured temperature

There are two tuning parameters to compensate:

- Channel gain compensation
- Channel phase delay compensation

Following are the compensation correspondences:

- Measured current RMS is per phase. It goes to I<sub>gain</sub> and Phi for each phase.
  - This is to compensate the non-linearity of current sensors, like a Current-Transformer. Non-linearity can be gain-nonlinearity or phase nonlinearity. The gain nonlinearity is compensated by I<sub>gain</sub> compensation and phase nonlinearity is compensated by phase compensation.
- Frequency compensation only goes to Phi/Delay (all phases are the same).
- Temperature compensation only goes to U<sub>Gain</sub> (per phase).

**Table-4 Compensation Related Registers**

Parameter	Description	Registers
LogI <sub>rms</sub>	Measured Current RMS	LOGI <sub>rms</sub> 0, LOGI <sub>rms</sub> 1
F0	Nominal line frequency	F0
T0	Nominal temperature	T0
GainI <sub>rms</sub>	Gain compensation for I <sub>rms</sub>	GainAI <sub>rms</sub> 01, GainAI <sub>rms</sub> 2, GainBI <sub>rms</sub> 01, GainBI <sub>rms</sub> 2, GainCI <sub>rms</sub> 01, GainCI <sub>rms</sub> 2
PhiI <sub>rms</sub>	Phase compensation for I <sub>rms</sub>	PhiAI <sub>rms</sub> 01, PhiAI <sub>rms</sub> 2, PhiBI <sub>rms</sub> 01, PhiBI <sub>rms</sub> 2, PhiCI <sub>rms</sub> 01, PhiCI <sub>rms</sub> 2
UGainT	Temperature compensation only goes to U <sub>Gain</sub>	UGainTAB, UGainTC
PhiF	Frequency compensation only goes to Phi/Delay	PhiFreqComp

#### 3.9.1 GAIN BASED COMPENSATION

The channel gain can be tuned automatically according to measured temperature and current RMS.

$$\text{Channel\_Gain} = \text{Gain0} * \left( 1 + \frac{\text{GainI}_{rms} * (\text{Log}(I_{rms}/I_{rms\_ref}))}{2^{19}} + \text{GainI}_{rms\_offset} \right)$$

$$\text{Channel\_Gain\_Voltage} = \text{UGain0} * \left( 1 + \frac{\text{UGainT} * (T - T0)}{2^{20}} \right)$$

Here

Log(x) = Log<sub>2</sub>(x)\*16, e.g.: Log(2) = 16, Log(16) = 64

- Gain0 is the calibrated Gain at nominal condition,
- GainI<sub>rms</sub> is the gain adjustment per I<sub>rms</sub> change (8 bit)
- I<sub>rms\_ref</sub> is the reference current RMS
- GainI<sub>rms\_offset</sub> is the offset for segment calibration
- U<sub>Gain</sub>0 is the calibrated Gain at nominal temperature
- U<sub>Gain</sub>T is the gain adjustment per temperature degree change,
- T0 is the nominal temperature,

If (I<sub>rms</sub> > I<sub>rms</sub>0)

$$\text{GainI}_{rms} = \text{GainI}_{rms0},$$

$$I_{rms\_ref} = I_{rms0},$$

$$\text{GainI}_{rms\_offset} = 0,$$

If (I<sub>rms</sub>1 < I<sub>rms</sub> < I<sub>rms</sub>0)

$$\text{GainI}_{rms} = \text{GainI}_{rms1},$$

$$I_{rms\_ref} = I_{rms0},$$

$$\text{GainI}_{rms\_offset} = 0,$$

If (I<sub>rms</sub> < I<sub>rms</sub>1)

$$\text{GainI}_{rms} = \text{GainI}_{rms2},$$

$$I_{rms\_ref} = I_{rms1}$$

$$\text{GainI}_{rms\_offset} = \frac{\text{GainI}_{rms1} * (\text{Log}(I_{rms1}/I_{rms0}))}{2^{19}}$$

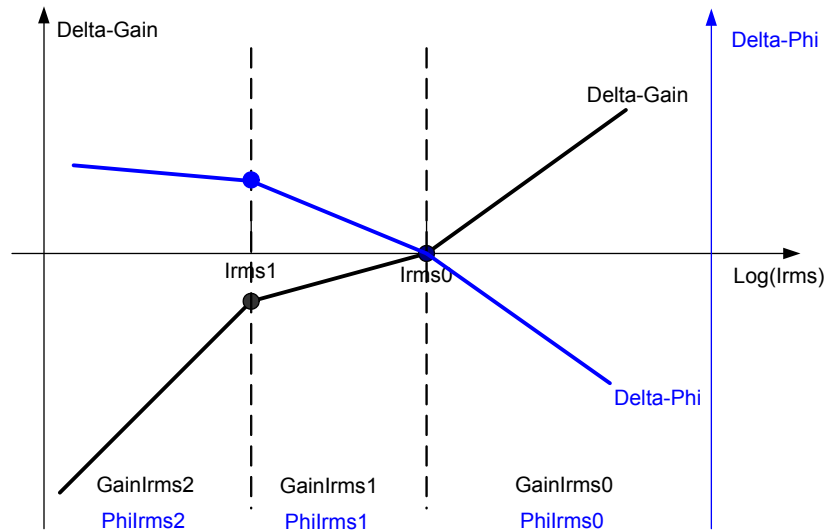

**Figure-15 Segment Gain Compensation**

**3.9.2 DELAY/PHASE BASED COMPENSATION**

The Channel phase compensation delay can be tuned according to the measured frequency and current RMS.

*Channel\_Phi*

$$= \text{Phi}0 + \frac{\text{Phi}F * (F - F0)}{512} + \frac{\text{Philrms} * (\text{Log}(\text{Irms} / \text{Irms\_ref}))}{256} + \text{Phi\_offset}$$

- Phi0 is the calibrated delay between the V/I channel (in terms of 2.048Mhz clock cycles)
- PhiF is the delay change per frequency change
- F0 is the nominal frequency,
- Philrms is the delay change per current change
- Phi\_offset is the offset for segment calibration
- $\text{Log}(x) = \text{Log}_2(x) * 16$

*If (Irms > Irms0)*

$$\text{Philrms} = \text{Philrms}0, \text{Irms\_ref} = \text{Irms}0,$$

$$\text{Phi\_offset} = 0$$

*If (Irms1 < Irms < Irms0)*

$$\text{Philrms} = \text{Philrms}1, \text{Irms\_ref} = \text{Irms}0,$$

$$\text{Phi\_offset} = 0$$

*If (Irms < Irms1)*

$$\text{Philrms} = \text{Philrms}2, \text{Irms\_ref} = \text{Irms}1,$$

$$\text{Phi\_offset} = \frac{\text{Philrms}1 * (\text{Log}(\text{Irms}1 / \text{Irms}0))}{256}$$

Implementation Note:

The channel\_phi could be computed at the 8Khz rate. The computed channel\_phi (before applied to the delay chain in the decimator) shall be averaged and updated every 8192 8Khz-samples (about one update per second). This is to attenuate the fluctuation generated in the computation when the current is small and avoid frequent updating of the delay, which is assumed to be a fixed value in the decimator.

## 4 SPI INTERFACE

### 4.1 INTERFACE DESCRIPTION

Four pins are associated with the interface as below:

- SDI – Data pin, input.
- SDO – Data pin, output.
- SCLK – Clock input pin.
- $\overline{\text{CS}}$  – Chip select pin Input.

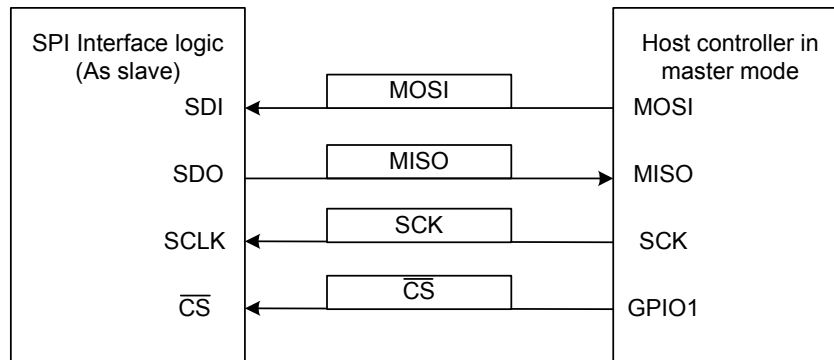

**Figure-16 Slave Mode**

## 4.2 SPI INTERFACE

The interface works in slave mode as shown in Figure-16.

### 4.2.1 SPI SLAVE INTERFACE FORMAT

In the SPI mode, data on SDI is shifted into the chip on the rising edge of SCLK while data on SDO is shifted out of the chip on the falling edge of SCLK.

Refer to Figure-17 and Figure-18 below for the timing diagram.

#### Access type:

The first bit on SDI defines the access type as below:

#### Read Sequence:

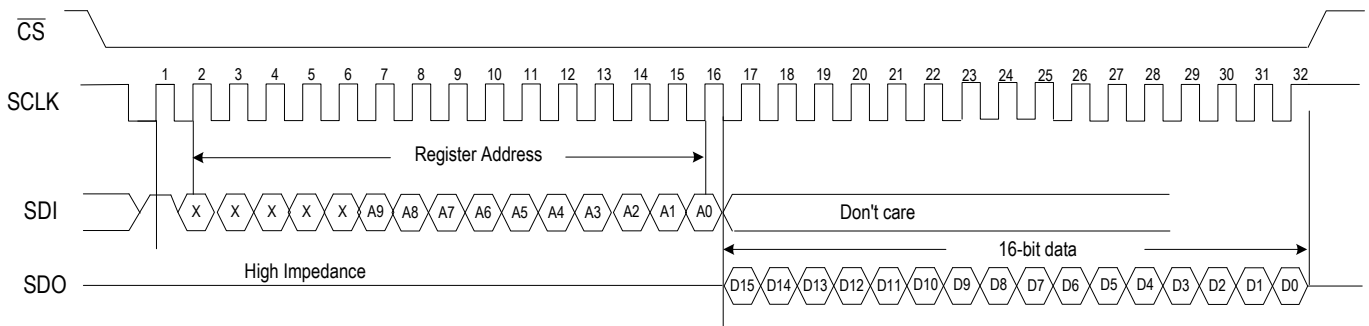

Figure-17 Read Sequence

#### Write Sequence:

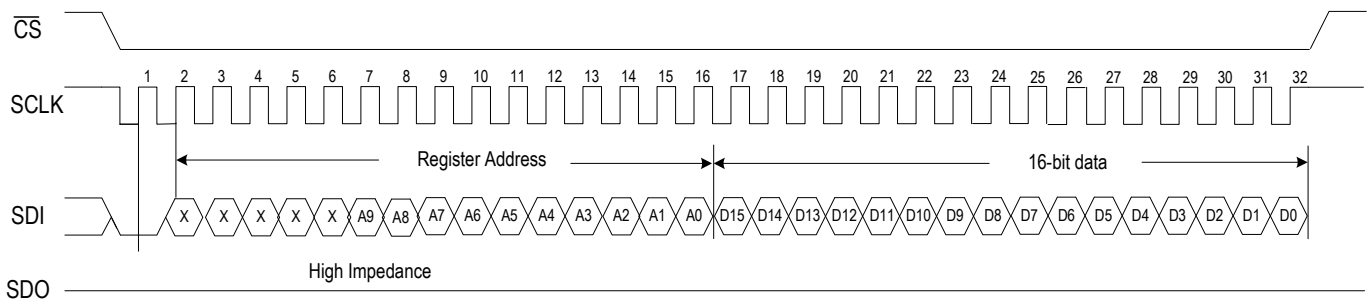

Figure-18 Write Sequence

### 4.2.2 RELIABILITY ENHANCEMENT FEATURE

The SPI read/write transaction is  $\overline{CS}$ -low defined. Each transaction can only access one register.

Within each  $\overline{CS}$ -low defined transaction:

Instruction	Description	Instruction Format
Read	read from registers	1
Write	write to registers	0

#### Address:

Fixed 15-bit, following the access type bits. The lower 10-bit is decoded as address; the higher 5 bits are 'Don't Care'.

#### Read/Write data:

Fixed as 16 bits.

Write: access occurs only when  $\overline{CS}$  goes from low to high and there are exactly 32 SCLK cycles received during  $\overline{CS}$  low period.

Read: if  $SCLK \geq 16$  (full address received), data is read out from internal registers and gets to the SDO pin; and the [LastSPIData](#) register is updated. The R/C registers can only be cleared after the [LastSPIData](#) register is updated.



## 5 REGISTER

### 5.1 REGISTER LIST

Table-5 Register List

Register Address	Register Name	Read/Write Type	Functional Description	Comment	Page
<b>Status and Special Register</b>					
00H	<a href="#">MeterEn</a>	R/W	Metering Enable		<a href="#">P 42</a>
01H	<a href="#">ChannelMapI</a>	R/W	Current Channel Mapping Configuration		<a href="#">P 43</a>
02H	<a href="#">ChannelMapU</a>	R/W	Voltage Channel Mapping Configuration		<a href="#">P 43</a>
05H	<a href="#">SagPeakDetCfg</a>	R/W	Sag and Peak Detector Period Configuration		<a href="#">P 45</a>
06H	<a href="#">OVth</a>	R/W	Over Voltage Threshold		<a href="#">P 45</a>
07H	<a href="#">ZXConfig</a>	R/W	Zero-Crossing Configuration	Configuration of ZX0/1/2 pins' source	<a href="#">P 45</a>
08H	<a href="#">SagTh</a>	R/W	Voltage Sag Threshold		<a href="#">P 46</a>
09H	<a href="#">PhaseLossTh</a>	R/W	Voltage Phase Losing Threshold	Similar to Voltage Sag Threshold register	<a href="#">P 46</a>
0AH	<a href="#">InWarnTh</a>	R/W	Neutral Current (Calculated) Warning Threshold		<a href="#">P 46</a>
0BH	<a href="#">Olth</a>	R/W	Over Current Threshold		<a href="#">P 46</a>
0CH	<a href="#">FreqLoTh</a>	R/W	Low Threshold for Frequency Detection		<a href="#">P 46</a>
0DH	<a href="#">FreqHiTh</a>	R/W	High Threshold for Frequency Detection		<a href="#">P 47</a>
0EH	<a href="#">PMPwrCtrl</a>	R/W	Partial Measurement Mode Power Control		<a href="#">P 47</a>
0FH	<a href="#">IRQ0MergeCfg</a>	R/W	IRQ0 Merge Configuration	Refer to <a href="#">4.2.2 Reliability Enhancement Feature</a>	<a href="#">P 47</a>
<b>Low Power Mode Register</b>					
10H	<a href="#">DetectCtrl</a>	R/W	Current Detect Control		<a href="#">P 48</a>
11H	<a href="#">DetectTh1</a>	R/W	Channel 1 Current Threshold in Detection Mode		<a href="#">P 49</a>
12H	<a href="#">DetectTh2</a>	R/W	Channel 2 Current Threshold in Detection Mode		<a href="#">P 49</a>
13H	<a href="#">DetectTh3</a>	R/W	Channel 3 Current Threshold in Detection Mode		<a href="#">P 49</a>
14H	<a href="#">IDCoffsetA</a>	R/W	Phase A Current DC offset		<a href="#">P 50</a>
15H	<a href="#">IDCoffsetB</a>	R/W	Phase B Current DC offset		<a href="#">P 50</a>
16H	<a href="#">IDCoffsetC</a>	R/W	Phase C Current DC offset		<a href="#">P 50</a>
17H	<a href="#">UDCoffsetA</a>	R/W	Voltage DC offset for Channel A		<a href="#">P 50</a>
18H	<a href="#">UDCoffsetB</a>	R/W	Voltage DC offset for Channel B		<a href="#">P 50</a>
19H	<a href="#">UDCoffsetC</a>	R/W	Voltage DC offset for Channel C		<a href="#">P 51</a>
1AH	<a href="#">UGainTAB</a>	R/W	Voltage Gain Temperature Compensation for Phase A/B		<a href="#">P 51</a>
1BH	<a href="#">UGainTC</a>	R/W	Voltage Gain Temperature Compensation for Phase C		<a href="#">P 51</a>
1CH	<a href="#">PhiFreqComp</a>	R/W	Phase Compensation for Frequency		<a href="#">P 51</a>
20H	<a href="#">LOGIrms0</a>	R/W	Current (Log Irms0) Configuration for Segment Compensation		<a href="#">P 51</a>
21H	<a href="#">LOGIrms1</a>	R/W	Current (Log Irms1) Configuration for Segment Compensation		<a href="#">P 51</a>
22H	<a href="#">F0</a>	R/W	Nominal Frequency		<a href="#">P 52</a>
23H	<a href="#">T0</a>	R/W	Nominal Temperature		<a href="#">P 52</a>
24H	<a href="#">PhiAlrms01</a>	R/W	Phase A Phase Compensation for Current Segment 0 and 1		<a href="#">P 52</a>
25H	<a href="#">PhiAlrms2</a>	R/W	Phase A Phase Compensation for Current Segment 2		<a href="#">P 52</a>

Table-5 Register List (Continued)

Register Address	Register Name	Read/Write Type	Functional Description	Comment	Page
26H	<a href="#">GainAlrms01</a>	R/W	Phase A Gain Compensation for Current Segment 0 and 1		<a href="#">P 53</a>
27H	<a href="#">GainAlrms2</a>	R/W	Phase A Gain Compensation for Current Segment 2		<a href="#">P 53</a>
28H	<a href="#">PhiBlrms01</a>	R/W	Phase B Phase Compensation for Current Segment 0 and 1		<a href="#">P 53</a>
29H	<a href="#">PhiBlrms2</a>	R/W	Phase B Phase Compensation for Current Segment 2		<a href="#">P 54</a>
2AH	<a href="#">GainBlrms01</a>	R/W	Phase B Gain Compensation for Current Segment 0 and 1		<a href="#">P 53</a>
2BH	<a href="#">GainBlrms2</a>	R/W	Phase B Gain Compensation for Current Segment 2		<a href="#">P 54</a>
2CH	<a href="#">PhiClrms01</a>	R/W	Phase C Phase Compensation for Current Segment 0 and 1		<a href="#">P 54</a>
2DH	<a href="#">PhiClrms2</a>	R/W	Phase C Phase Compensation for Current Segment 2		<a href="#">P 54</a>
2EH	<a href="#">GainClrms01</a>	R/W	Phase C Gain Compensation for Current Segment 0 and 1		<a href="#">P 54</a>
2FH	<a href="#">GainClrms2</a>	R/W	Phase C Gain Compensation for Current Segment 2		<a href="#">P 54</a>
<b>Configuration Registers</b>					
31H	<a href="#">PLconstH</a>	R/W	High Word of PL_Constant	Refer to <a href="#">Table-6</a> .	<a href="#">P 55</a>
32H	<a href="#">PLconstL</a>	R/W	Low Word of PL_Constant		<a href="#">P 55</a>
33H	<a href="#">MMode0</a>	R/W	Metering Method Configuration		<a href="#">P 56</a>
34H	<a href="#">MMode1</a>	R/W	PGA Gain Configuration		<a href="#">P 57</a>
35H	<a href="#">PStartTh</a>	R/W	Active Startup Power Threshold		
36H	<a href="#">QStartTh</a>	R/W	Reactive Startup Power Threshold		
37H	<a href="#">SStartTh</a>	R/W	Apparent Startup Power Threshold		
38H	<a href="#">PPhaseTh</a>	R/W	Startup Power Threshold for Any Phase (Active Energy Accumulation)		
39H	<a href="#">QPhaseTh</a>	R/W	Startup Power Threshold for Any Phase (ReActive Energy Accumulation)		
3AH	<a href="#">SPhaseTh</a>	R/W	Startup Power Threshold for Any Phase (Apparent Energy Accumulation)		
<b>Calibration Registers</b>					
41H	<a href="#">PoffsetA</a>	R/W	Phase A Active Power offset	Refer to <a href="#">Table-7</a> .	<a href="#">P 58</a>
42H	<a href="#">QoffsetA</a>	R/W	Phase A Reactive Power offset		<a href="#">P 58</a>
43H	<a href="#">PoffsetB</a>	R/W	Phase B Active Power offset		
44H	<a href="#">QoffsetB</a>	R/W	Phase B Reactive Power offset		
45H	<a href="#">PoffsetC</a>	R/W	Phase C Active Power offset		
46H	<a href="#">QoffsetC</a>	R/W	Phase C Reactive Power offset		
47H	<a href="#">GainA</a>	R/W	Phase A Calibration Gain		<a href="#">P 58</a>
48H	<a href="#">PhiA</a>	R/W	Phase A Calibration Phase Angle		<a href="#">P 58</a>
49H	<a href="#">PQGainB</a>	R/W	Phase B Calibration Gain		
4AH	<a href="#">PhiB</a>	R/W	Phase B Calibration Phase Angle		
4BH	<a href="#">PQGainC</a>	R/W	Phase C Calibration Gain		
4CH	<a href="#">PhiC</a>	R/W	Phase C Calibration Phase Angle		

Table-5 Register List (Continued)

Register Address	Register Name	Read/Write Type	Functional Description	Comment	Page
<b>Fundamental/ Harmonic Energy Calibration Registers</b>					
51H	PoffsetAF	R/W	Phase A Fundamental Active Power offset	Refer to <a href="#">Table-8</a> .	
52H	PoffsetBF	R/W	Phase B Fundamental Active Power offset		
53H	PoffsetCF	R/W	Phase C Fundamental Active Power offset		
54H	PGainAF	R/W	Phase A Fundamental Calibration Gain		
55H	PGainBF	R/W	Phase B Fundamental Calibration Gain		
56H	PGainCF	R/W	Phase C Fundamental Calibration Gain		
<b>Measurement Calibration Registers</b>					
61H	UgainA	R/W	Phase A Voltage RMS Gain	Refer to <a href="#">Table-9</a> .	
62H	IgainA	R/W	Phase A Current RMS Gain		
63H	UoffsetA	R/W	Phase A Voltage RMS offset		
64H	IoffsetA	R/W	Phase A Current RMS offset		
65H	UgainB	R/W	Phase B Voltage RMS Gain		
66H	IgainB	R/W	Phase B Current RMS Gain		
67H	UoffsetB	R/W	Phase B Voltage RMS offset		
68H	IoffsetB	R/W	Phase B Current RMS offset		
69H	UgainC	R/W	Phase C Voltage RMS Gain		
6AH	IgainC	R/W	Phase C Current RMS Gain		
6BH	UoffsetC	R/W	Phase C Voltage RMS offset		
6CH	IoffsetC	R/W	Phase C Current RMS offset		
<b>EMM Status Registers</b>					
70H	<a href="#">SoftReset</a>	R/W	Software Reset		<a href="#">P 59</a>
71H	<a href="#">EMMState0</a>	R	EMM State 0		<a href="#">P 60</a>
72H	<a href="#">EMMState1</a>	R	EMM State 1		<a href="#">P 61</a>
73H	<a href="#">EMMIntState0</a>	R/W1C	EMM Interrupt Status 0		<a href="#">P 61</a>
74H	<a href="#">EMMIntState1</a>	R/W1C	EMM Interrupt Status 1		<a href="#">P 62</a>
75H	<a href="#">EMMIntEn0</a>	R/W	EMM Interrupt Enable 0		<a href="#">P 63</a>
76H	<a href="#">EMMIntEn1</a>	R/W	EMM Interrupt Enable 1		<a href="#">P 64</a>
78H	<a href="#">LastSPIData</a>	R	Last Read/Write SPI Value		<a href="#">P 64</a>
79H	<a href="#">CRCErrStatus</a>	R	CRC Error Status		<a href="#">P 64</a>
7AH	<a href="#">CRCDigest</a>	R/W	CRC Digest		<a href="#">P 65</a>
7FH	<a href="#">CfgRegAccEn</a>	R/W	Configure Register Access Enable		<a href="#">P 65</a>

Table-5 Register List (Continued)

Register Address	Register Name	Read/Write Type	Functional Description	Comment	Page
<b>Energy Register</b>					
80H	APenergyT	R/C	Total Forward Active Energy	Refer to <a href="#">Table-11</a> .	P 66
81H	APenergyA	R/C	Phase A Forward Active Energy		
82H	APenergyB	R/C	Phase B Forward Active Energy		
83H	APenergyC	R/C	Phase C Forward Active Energy		
84H	ANenergyT	R/C	Total Reverse Active Energy		
85H	ANenergyA	R/C	Phase A Reverse Active Energy		
86H	ANenergyB	R/C	Phase B Reverse Active Energy		
87H	ANenergyC	R/C	Phase C Reverse Active Energy		
88H	RPenergyT	R/C	Total Forward Reactive Energy		
89H	RPenergyA	R/C	Phase A Forward Reactive Energy		
8AH	RPenergyB	R/C	Phase B Forward Reactive Energy		
8BH	RPenergyC	R/C	Phase C Forward Reactive Energy		
8CH	RNenergyT	R/C	Total Reverse Reactive Energy		
8DH	RNenergyA	R/C	Phase A Reverse Reactive Energy		
8EH	RNenergyB	R/C	Phase B Reverse Reactive Energy		
8FH	RNenergyC	R/C	Phase C Reverse Reactive Energy		
90H	SAenergyT	R/C	Total (Arithmetic Sum) Apparent Energy		
91H	SenenergyA	R/C	Phase A Apparent Energy		
92H	SenenergyB	R/C	Phase B Apparent Energy		
93H	SenenergyC	R/C	Phase C Apparent Energy		
<b>Fundamental / Harmonic Energy Register</b>					
A0H	APenergyTF	R/C	Total Forward Active Fundamental Energy	Refer to <a href="#">Table-12</a> .	P 67
A1H	APenergyAF	R/C	Phase A Forward Active Fundamental Energy		
A2H	APenergyBF	R/C	Phase B Forward Active Fundamental Energy		
A3H	APenergyCF	R/C	Phase C Forward Active Fundamental Energy		
A4H	ANenergyTF	R/C	Total Reverse Active Fundamental Energy		
A5H	ANenergyAF	R/C	Phase A Reverse Active Fundamental Energy		
A6H	ANenergyBF	R/C	Phase B Reverse Active Fundamental Energy		
A7H	ANenergyCF	R/C	Phase C Reverse Active Fundamental Energy		
A8H	APenergyTH	R/C	Total Forward Active Harmonic Energy		
A9H	APenergyAH	R/C	Phase A Forward Active Harmonic Energy		
AAH	APenergyBH	R/C	Phase B Forward Active Harmonic Energy		
ABH	APenergyCH	R/C	Phase C Forward Active Harmonic Energy		
ACH	ANenergyTH	R/C	Total Reverse Active Harmonic Energy		
ADH	ANenergyAH	R/C	Phase A Reverse Active Harmonic Energy		
AEH	ANenergyBH	R/C	Phase B Reverse Active Harmonic Energy		
AFH	ANenergyCH	R/C	Phase C Reverse Active Harmonic Energy		

Table-5 Register List (Continued)

Register Address	Register Name	Read/Write Type	Functional Description	Comment	Page
<b>Power and Power Factor Registers</b>					
B0H	PmeanT	R	Total (all-phase-sum) Active Power	Refer to <a href="#">Table-13</a> .	<a href="#">P 68</a>
B1H	PmeanA	R	Phase A Active Power		
B2H	PmeanB	R	Phase B Active Power		
B3H	PmeanC	R	Phase C Active Power		
B4H	QmeanT	R	Total (all-phase-sum) Reactive Power		
B5H	QmeanA	R	Phase A Reactive Power		
B6H	QmeanB	R	Phase B Reactive Power		
B7H	QmeanC	R	Phase C Reactive Power		
B8H	SmeanT	R	Total (Arithmetic Sum) Apparent Power		
B9H	SmeanA	R	Phase A Apparent Power		
BAH	SmeanB	R	Phase B Apparent Power		
BBH	SmeanC	R	Phase C Apparent Power		
BCH	PFmeanT	R	Total Power Factor		
BDH	PFmeanA	R	Phase A Power Factor		
BEH	PFmeanB	R	Phase B Power Factor		
BFH	PFmeanC	R	Phase C Power Factor		
C0H	PmeanTLSB	R	Lower Word of Total (all-phase-sum) Active Power		
C1H	PmeanALSB	R	Lower Word of Phase A Active Power		
C2H	PmeanBLSB	R	Lower Word of Phase B Active Power		
C3H	PmeanCLSB	R	Lower Word of Phase C Active Power		
C4H	QmeanTLSB	R	Lower Word of Total (all-phase-sum) Reactive Power		
C5H	QmeanALSB	R	Lower Word of Phase A Reactive Power		
C6H	QmeanBLSB	R	Lower Word of Phase B Reactive Power		
C7H	QmeanCLSB	R	Lower Word of Phase C Reactive Power		
C8H	SAmeanTLSB	R	Lower Word of Total (Arithmetic Sum) Apparent Power		
C9H	SmeanALSB	R	Lower Word of Phase A Apparent Power		
CAH	SmeanBLSB	R	Lower Word of Phase B Apparent Power		
CBH	SmeanCLSB	R	Lower Word of Phase C Apparent Power		

Table-5 Register List (Continued)

Register Address	Register Name	Read/Write Type	Functional Description	Comment	Page
<b>Fundamental / Harmonic Power and Voltage / Current RMS Registers</b>					
D0H	PmeanTF	R	Total Active Fundamental Power	Refer to <a href="#">Table-14</a> .	P 68
D1H	PmeanAF	R	Phase A Active Fundamental Power		
D2H	PmeanBF	R	Phase B Active Fundamental Power		
D3H	PmeanCF	R	Phase C Active Fundamental Power		
D4H	PmeanTH	R	Total Active Harmonic Power		
D5H	PmeanAH	R	Phase A Active Harmonic Power		
D6H	PmeanBH	R	Phase B Active Harmonic Power		
D7H	PmeanCH	R	Phase C Active Harmonic Power		
D9H	UrmsA	R	Phase A Voltage RMS		
DAH	UrmsB	R	Phase B Voltage RMS		
DBH	UrmsC	R	Phase C Voltage RMS		
DCH	IrmsN	R	N Line Calculated Current RMS		
DDH	IrmsA	R	Phase A Current RMS		
DEH	IrmsB	R	Phase B Current RMS		
DFH	IrmsC	R	Phase C Current RMS		
E0H	PmeanTFLSB	R	Lower Word of Total Active Fundamental Power		
E1H	PmeanAFLSB	R	Lower Word of Phase A Active Fundamental Power		
E2H	PmeanBFLSB	R	Lower Word of Phase B Active Fundamental Power		
E3H	PmeanCFLSB	R	Lower Word of Phase C Active Fundamental Power		
E4H	PmeanTHLSB	R	Lower Word of Total Active Harmonic Power		
E5H	PmeanAHLSB	R	Lower Word of Phase A Active Harmonic Power		
E6H	PmeanBHLSB	R	Lower Word of Phase B Active Harmonic Power		
E7H	PmeanCHLSB	R	Lower Word of Phase C Active Harmonic Power		
E9H	UrmsALSB	R	Lower Word of Phase A Voltage RMS		
EAH	UrmsBLSB	R	Lower Word of Phase B Voltage RMS		
EBH	UrmsCLSB	R	Lower Word of Phase C Voltage RMS		
EDH	IrmsALSB	R	Lower Word of Phase A Current RMS		
EEH	IrmsBLSB	R	Lower Word of Phase B Current RMS		
EFH	IrmsCLSB	R	Lower Word of Phase C Current RMS		

Table-5 Register List (Continued)

Register Address	Register Name	Read/Write Type	Functional Description	Comment	Page
<b>Peak, Frequency, Angle and Temperature Registers</b>					
F1H	<a href="#">UPeakA</a>	R	Channel A Voltage Peak	Refer to <a href="#">Table-15</a> .	<a href="#">P 70</a>
F2H	<a href="#">IPeakA</a>	R	Channel A Current Peak		<a href="#">P 70</a>
F3H	UPeakB	R	Channel B Voltage Peak		
F5H	IPeakB	R	Channel B Current Peak		
F6H	UPeakC	R	Channel C Voltage Peak		
F7H	IPeakC	R	Channel C Current Peak		
F8H	Freq	R	Frequency		
F9H	PAngleA	R	Phase A Mean Phase Angle		
FAH	PAngleB	R	Phase B Mean Phase Angle		
FBH	PAngleC	R	Phase C Mean Phase Angle		
FCH	Temp	R	Measured Temperature		
FDH	UangleA	R	Phase A Voltage Phase Angle		
FEH	UangleB	R	Phase B Voltage Phase Angle		
FFH	UangleC	R	Phase C Voltage Phase Angle		

## 5.2 SPECIAL REGISTERS

### 5.2.1 CONFIGURATION REGISTERS CRC GENERATION

The registers between address '0H' to '6FH' are considered as user configuration registers. CRC-16 with the following polynomial was used to compute the CRC digest:

$$Polynomial = x^{16} + x^{12} + x^5 + 1$$

The CRC computation rate is every 16 bit word per 125us. The result can be read from the CRC result register.

The device can automatically monitor the CRC changes versus a golden CRC which is latched after the first time the CRC computation is done. The latching event is triggered by none "0x55AA" value written to the [CfgRegAccEn](#) register (which means configuration done), followed by a new CRC result available event. Once golden CRC is latched, the CRC\_CMP signal is enabled. Subsequent CRC result will be compared with the latched CRC to generate the CRC error status. CRC error status can be read, and if configured, can go to WARN or IRQ0 pins to alert the MCU in the case of CRC error.

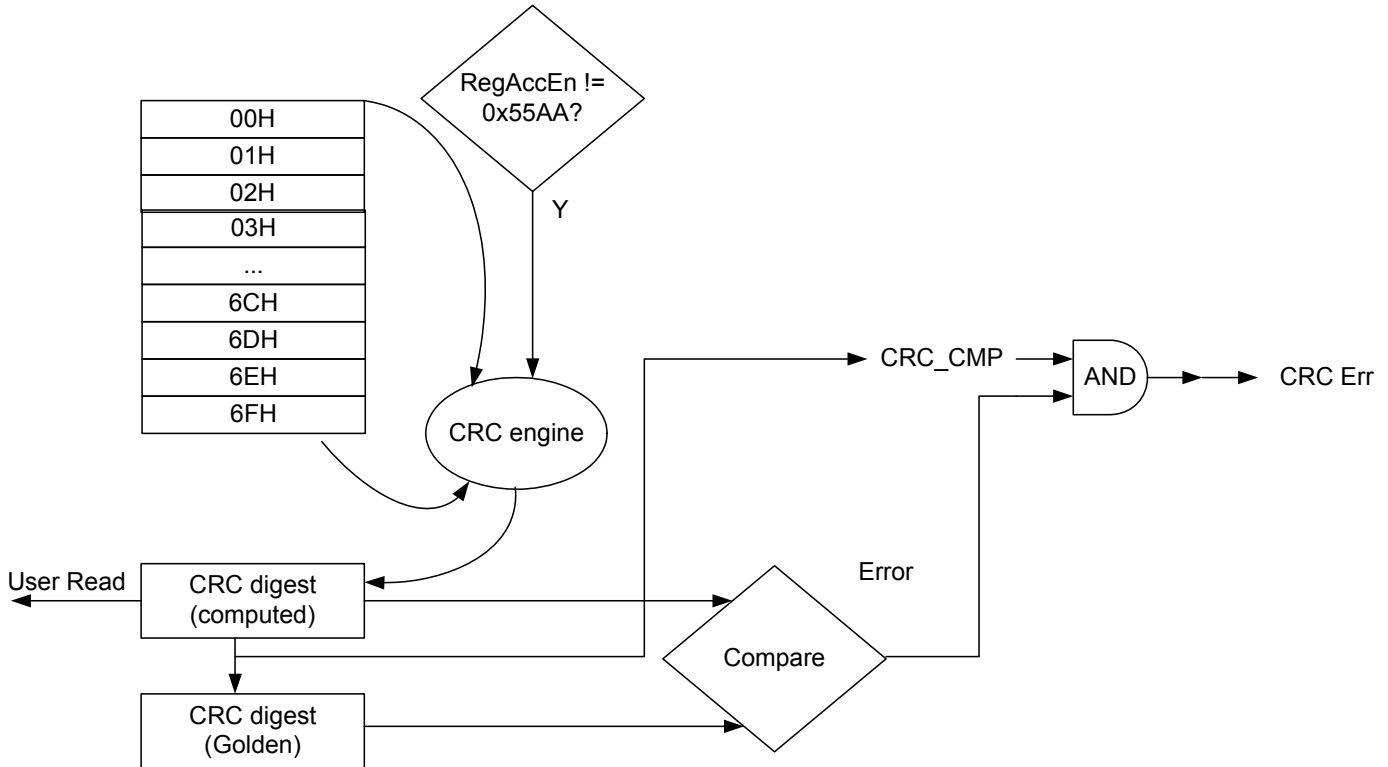

Figure-19 CRC Checking Diagram



## 5.2.2 IRQ AND WARNOUT SIGNAL GENERATION

The interrupt generation scheme is consistent for all the interrupt sources. For any interrupt source, there is an interrupt status register and an interrupt enable register. Interrupt status register latches the interrupt event and is always available for polling. If the interrupt enable register is set, that interrupt can go to IRQ pin to notify the processor.

The interrupt status register is write-1-to-clear. It captures the interrupt event which is usually an internal state change. The (real time) internal state for that event is also available for read at any time.

The following diagram illustrates how the status bits, enable bits and IRQ/ WarnOut pins work together.

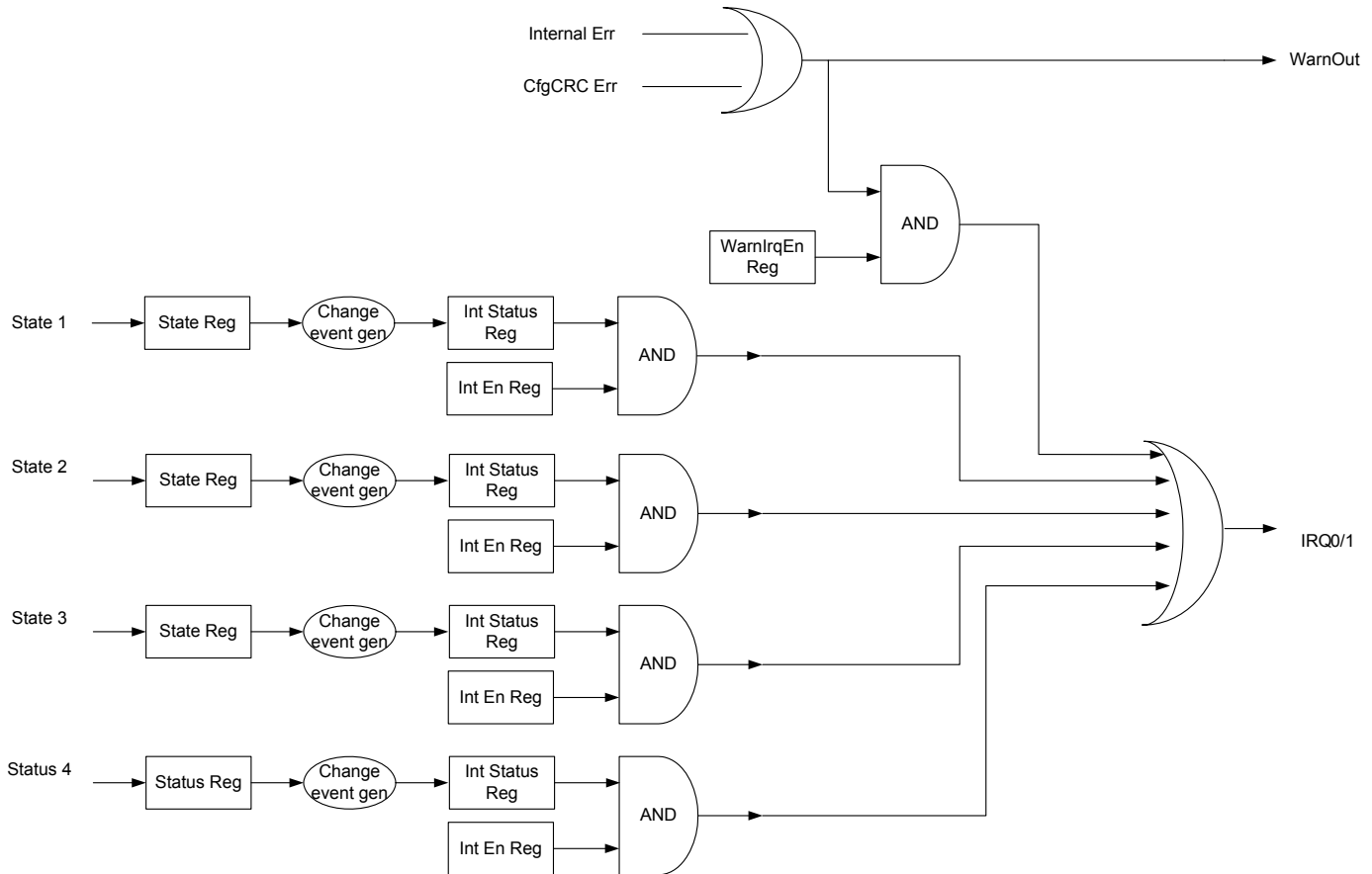

**Figure-20 IRQ and WarnOut Generation**

There are two interrupt output pins: IRQ0 and IRQ1.

The IRQ 0 is associated with interrupt sources defined in [EMMState0](#) register.

The IRQ 1 is associated with interrupt sources defined in [EMMState1](#) register.

If configured, IRQ 1 state can be ORed together with IRQ0 state and output to IRQ0, in that case MCU need only process one IRQ pin. It is up to system designer to trade off between conveniences of locating interrupt source and saving GPIO pins.

The Warn pin will be asserted when there is a configuration register CRC check error. The Warn signal can be merged to IRQ0 if configured.

**MeterEn**  
**Metering Enable**

Address: 00H  
Type: Read/Write  
Default Value: 00H

Bit	Name	Description
7:0	MeterEn[7:0]	Metering is enabled when any bit in this register is set.

### ChannelMap1 Current Channel Mapping Configuration

Address: 01H  
Type: Read/Write  
Default Value: 0210H

Bit	Name	Description																		
15:11	-	Reserved.																		
10:8	IC_SRC	ADC Input source for phase C current channel  <table border="1"> <thead> <tr> <th>Code</th> <th>ADC Input Source</th> </tr> </thead> <tbody> <tr><td>000</td><td>I0</td></tr> <tr><td>001</td><td>I1</td></tr> <tr><td>010</td><td>I2</td></tr> <tr><td>011</td><td>Fixed-0</td></tr> <tr><td>100</td><td>U0</td></tr> <tr><td>101</td><td>U1</td></tr> <tr><td>110</td><td>U2</td></tr> <tr><td>111</td><td>Fixed-0</td></tr> </tbody> </table>	Code	ADC Input Source	000	I0	001	I1	010	I2	011	Fixed-0	100	U0	101	U1	110	U2	111	Fixed-0
Code	ADC Input Source																			
000	I0																			
001	I1																			
010	I2																			
011	Fixed-0																			
100	U0																			
101	U1																			
110	U2																			
111	Fixed-0																			
7	-	Reserved.																		
6:4	IB_SRC	ADC Input source for phase B current channel  <table border="1"> <thead> <tr> <th>Code</th> <th>ADC Input Source</th> </tr> </thead> <tbody> <tr><td>000</td><td>I0</td></tr> <tr><td>001</td><td>I1</td></tr> <tr><td>010</td><td>I2</td></tr> <tr><td>011</td><td>Fixed-0</td></tr> <tr><td>100</td><td>U0</td></tr> <tr><td>101</td><td>U1</td></tr> <tr><td>110</td><td>U2</td></tr> <tr><td>111</td><td>Fixed-0</td></tr> </tbody> </table>	Code	ADC Input Source	000	I0	001	I1	010	I2	011	Fixed-0	100	U0	101	U1	110	U2	111	Fixed-0
Code	ADC Input Source																			
000	I0																			
001	I1																			
010	I2																			
011	Fixed-0																			
100	U0																			
101	U1																			
110	U2																			
111	Fixed-0																			
3	-	Reserved.																		
2:0	IA_SRC	ADC Input source for phase A current channel  <table border="1"> <thead> <tr> <th>Code</th> <th>ADC Input Source</th> </tr> </thead> <tbody> <tr><td>000</td><td>I0</td></tr> <tr><td>001</td><td>I1</td></tr> <tr><td>010</td><td>I2</td></tr> <tr><td>011</td><td>Fixed-0</td></tr> <tr><td>100</td><td>U0</td></tr> <tr><td>101</td><td>U1</td></tr> <tr><td>110</td><td>U2</td></tr> <tr><td>111</td><td>Fixed-0</td></tr> </tbody> </table>	Code	ADC Input Source	000	I0	001	I1	010	I2	011	Fixed-0	100	U0	101	U1	110	U2	111	Fixed-0
Code	ADC Input Source																			
000	I0																			
001	I1																			
010	I2																			
011	Fixed-0																			
100	U0																			
101	U1																			
110	U2																			
111	Fixed-0																			

### ChannelMapU Voltage Channel Mapping Configuration

Address: 02H  
Type: Read/Write  
Default Value: 0654H

Bit	Name	Description																		
15:11	-	Reserved.																		
10:8	UC_SRC	ADC Input source for phase C voltage channel  <table border="1"> <thead> <tr> <th>Code</th> <th>ADC Input Source</th> </tr> </thead> <tbody> <tr><td>000</td><td>I0</td></tr> <tr><td>001</td><td>I1</td></tr> <tr><td>010</td><td>I2</td></tr> <tr><td>011</td><td>Fixed-0</td></tr> <tr><td>100</td><td>U0</td></tr> <tr><td>101</td><td>U1</td></tr> <tr><td>110</td><td>U2</td></tr> <tr><td>111</td><td>Fixed-0</td></tr> </tbody> </table>	Code	ADC Input Source	000	I0	001	I1	010	I2	011	Fixed-0	100	U0	101	U1	110	U2	111	Fixed-0
Code	ADC Input Source																			
000	I0																			
001	I1																			
010	I2																			
011	Fixed-0																			
100	U0																			
101	U1																			
110	U2																			
111	Fixed-0																			
7	-	Reserved.																		
6:4	UB_SRC	ADC Input source for phase B voltage channel  <table border="1"> <thead> <tr> <th>Code</th> <th>ADC Input Source</th> </tr> </thead> <tbody> <tr><td>000</td><td>I0</td></tr> <tr><td>001</td><td>I1</td></tr> <tr><td>010</td><td>I2</td></tr> <tr><td>011</td><td>Fixed-0</td></tr> <tr><td>100</td><td>U0</td></tr> <tr><td>101</td><td>U1</td></tr> <tr><td>110</td><td>U2</td></tr> <tr><td>111</td><td>Fixed-0</td></tr> </tbody> </table>	Code	ADC Input Source	000	I0	001	I1	010	I2	011	Fixed-0	100	U0	101	U1	110	U2	111	Fixed-0
Code	ADC Input Source																			
000	I0																			
001	I1																			
010	I2																			
011	Fixed-0																			
100	U0																			
101	U1																			
110	U2																			
111	Fixed-0																			
3	-	Reserved.																		
2:0	UA_SRC	ADC Input source for phase A voltage channel  <table border="1"> <thead> <tr> <th>Code</th> <th>ADC Input Source</th> </tr> </thead> <tbody> <tr><td>000</td><td>I0</td></tr> <tr><td>001</td><td>I1</td></tr> <tr><td>010</td><td>I2</td></tr> <tr><td>011</td><td>Fixed-0</td></tr> <tr><td>100</td><td>U0</td></tr> <tr><td>101</td><td>U1</td></tr> <tr><td>110</td><td>U2</td></tr> <tr><td>111</td><td>Fixed-0</td></tr> </tbody> </table>	Code	ADC Input Source	000	I0	001	I1	010	I2	011	Fixed-0	100	U0	101	U1	110	U2	111	Fixed-0
Code	ADC Input Source																			
000	I0																			
001	I1																			
010	I2																			
011	Fixed-0																			
100	U0																			
101	U1																			
110	U2																			
111	Fixed-0																			

### SagPeakDetCfg Sag and Peak Detector Period Configuration

Address: 05H Type: Read/Write Default Value: 143FH		
Bit	Name	Description
15:8	PeakDet_period	Period in which the peak detector detects the U/I peak. Unit is ms.
7:0	Sag_Period	Period in which the phase voltage needs to stay below the <a href="#">SagTh</a> before to assert the Sag status. Unit is ms. The Phase Loss detector also uses this parameter in detecting Phase Loss.

### OVth Over Voltage Threshold

Address: 06H Type: Read/Write Default Value: C000H		
Bit	Name	Description
15:0	OVth	Over Voltage threshold. 0xFFFF maps to ADC output full-scale peak.

## 5.2.3 SPECIAL CONFIGURATION REGISTERS

### ZXConfig Zero-Crossing Configuration

Address: 07H Type: Read/Write Default Value: 0001H																				
Bit	Name	Description																		
15:13	ZX2Src[2:0]	These bits select the signal source for the ZX2, ZX1 or ZX0 pins.																		
12:10	ZX1Src[2:0]																			
9:7	ZX0Src[2:0]	<table border="1"> <thead> <tr> <th>Code</th> <th>Source</th> </tr> </thead> <tbody> <tr> <td>011</td> <td>Fixed-0</td> </tr> <tr> <td>000</td> <td>Ua</td> </tr> <tr> <td>001</td> <td>Ub</td> </tr> <tr> <td>010</td> <td>Uc</td> </tr> <tr> <td>111</td> <td>Fixed-0</td> </tr> <tr> <td>100</td> <td>Ia</td> </tr> <tr> <td>101</td> <td>Ib</td> </tr> <tr> <td>110</td> <td>Ic</td> </tr> </tbody> </table>	Code	Source	011	Fixed-0	000	Ua	001	Ub	010	Uc	111	Fixed-0	100	Ia	101	Ib	110	Ic
		Code	Source																	
		011	Fixed-0																	
		000	Ua																	
		001	Ub																	
		010	Uc																	
		111	Fixed-0																	
		100	Ia																	
101	Ib																			
110	Ic																			
6:5	ZX2Con[1:0]	These bits configure zero-crossing type for the ZX2, ZX1 and ZX0 pins.																		
4:3	ZX1Con[1:0]																			
2:1	ZX0Con[1:0]	<table border="1"> <thead> <tr> <th>Code</th> <th>Zero-Crossing Configuration</th> </tr> </thead> <tbody> <tr> <td>00</td> <td>Positive Zero-crossing</td> </tr> <tr> <td>01</td> <td>Negative Zero-crossing</td> </tr> <tr> <td>10</td> <td>All Zero-crossing</td> </tr> <tr> <td>11</td> <td>No Zero-crossing Output</td> </tr> </tbody> </table>	Code	Zero-Crossing Configuration	00	Positive Zero-crossing	01	Negative Zero-crossing	10	All Zero-crossing	11	No Zero-crossing Output								
		Code	Zero-Crossing Configuration																	
		00	Positive Zero-crossing																	
		01	Negative Zero-crossing																	
10	All Zero-crossing																			
11	No Zero-crossing Output																			
0	ZXdis	This bit determines whether to disable the ZX signals: 0: enable 1: disable all the ZX signals to '0' (default).																		

### SagTh Voltage Sag Threshold

Address: 08H  
Type: Read/Write  
Default Value: 1000H

Bit	Name	Description
15:0	SagTh	Voltage sag threshold level. 0xFFFF map to ADC output full-scale peak.

### PhaseLossTh Voltage Phase Losing Threshold

Address: 09H  
Type: Read/Write  
Default Value: 0400H

Bit	Name	Description
15:0	PhaseLossTh	PhaseLoss threshold level 0xFFFF map to ADC output full-scale peak.

### InWarnTh Neutral Current (Calculated) Warning Threshold

Address: 0AH  
Type: Read/Write  
Default Value: FFFFH

Bit	Name	Description
15:0	INWarnTh0	Neutral current (calculated) warning threshold. Threshold for calculated (Ia + Ib +Ic) N line rms current. Unsigned 16 bit, unit 1mA. If N line rms current is greater than the threshold, the INOV0ST bit (b7, <a href="#">EMMState0</a> ) bit is asserted if enabled. Refer to <a href="#">3.7.5 Neutral Line Overcurrent Detection</a> .

### Olth Over Current Threshold

Address: 0BH  
Type: Read/Write  
Default Value: C000H

Bit	Name	Description
15:0	Olth	Over Current threshold. 0xFFFF maps to ADC output full-scale peak.

### FreqLoTh Low Threshold for Frequency Detection

Address: 0CH  
Type: Read/Write  
Default Value: 1324H

Bit	Name	Description
15:0	FreqLoTh	Low threshold for frequency detection.

### FreqHiTh High Threshold for Frequency Detection

Address: 0DH  
Type: Read/Write  
Default Value: 13ECH

Bit	Name	Description
15:0	FreqHiTh	High threshold for frequency detection.

### PMPwrCtrl Partial Measurement Mode Power Control

Address: 0EH  
Type: Read/Write  
Default Value: 010FH

Bit	Name	Description
15:9	-	Reserved.
8	PMPwrDownVch	In Partial Measurement Mode the V0/V1/V2 analog channel can be powered off to save power 0: Power on 1: Power off This feature can be used when voltage measurement is not required in partial mode.
3	ACTRL_CLK_GATE	Power off the clock of analog control block to save power. 0: Power on 1: Power off
2	DSP_CLK_GATE	Power off the clock of DSP register to save power. 0: Power on 1: Power off
1	MTMS_CLK_GATE	Power off the metering and measuring block to save power. 0: Power on 1: Power off
0	PMClkLow	In Partial Measurement Mode the main clock can be reduced to 8.192MHz to save power. 0: 16.384MHz 1: 8.192MHz In this low rate mode, the SPI interface only support half the access rate at normal mode.

### IRQ0MergeCfg IRQ0 Merge Configuration

Address: 0FH  
Type: Read/Write  
Default Value: 0000H

Bit	Name	Description
15:2	-	Reserved.
1	WARN_OR	The WARN state can be ORed to IRQ0 output 0: normal 1: ORed
0	IRQ1_OR	The IRQ1 state can be ORed to IRQ0 output 0: normal 1: ORed

## 5.3 LOW-POWER MODES REGISTERS

### 5.3.1 DETECTION MODE REGISTERS

Current Detection register latching scheme is:

When any of the 4 current detection registers (0x10 - 0x13) were programmed, all the 4 current detection registers (including the registers that not being programmed) will be automatically latched into the current detector's internal configuration latches at the same time. Those latched configuration values are not subject to digital reset signals and will be kept in all the 4 power modes. The power up value of those latches is not deterministic, so user needs to program the current detection registers to update.

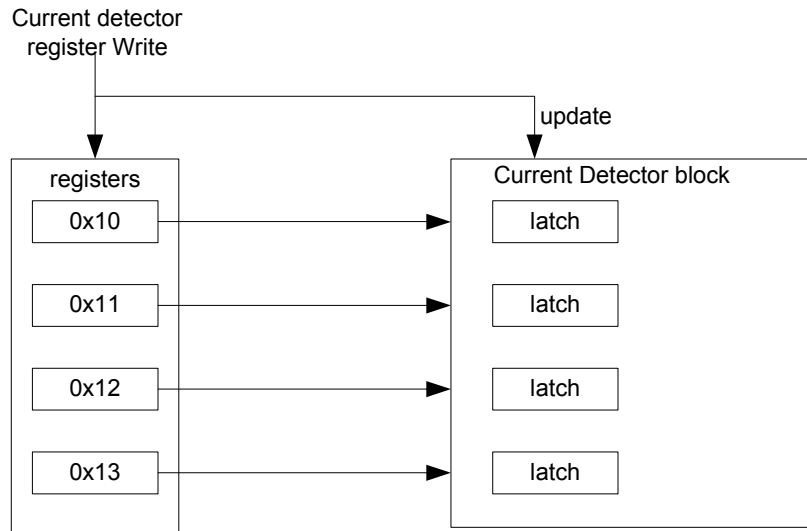

**Figure-21 Current Detection Register Latching Scheme**

#### DetectCtrl Current Detect Control

Address: 10H		
Type: Read/Write		
Default Value: xxxxH		
Bit	Name	Description
15:7	-	Must be written '3'.
6	DetCalEn	Detector calibration in Normal mode is enabled if this bit is set. The default written value is '0'. If set, current detectors are enabled and IRQ0/1 are assigned to current detector outputs as in Detect mode. The current detector can be calibrated.
5:0	DetectCtrl	Detector power-down, active high: [5:3]: Power-down for negative detector of channel 3/2/1; [2:0]: Power-down for positive detector of channel 3/2/1. The default written value is '0'.



### DetectTh1 Channel 1 Current Threshold in Detection Mode

Address: 11H Type: Read/Write Default Value: 0000H		
Bit	Name	Description
15:8	CalCodeN	Channel 1 current negative detector calculation code. Code mapping: 7'b000-0000, Vc = -1.2mV = -0.85mVrms (Vc is the threshold of low power computation) 7'b111-1111, Vc = 9mV = 6.35mVrms DAC typical resolution is $[9 - (-1.2)]/256 = 40\mu\text{V} = 28\mu\text{Vrms}$
7:0	CalCodeP	Channel 1 current positive detector calculation code. Code mapping: 7'b000-0000, Vc = -1.2mV = -0.85mVrms (Vc is the threshold of low power computation) 7'b111-1111, Vc = 9mV = 6.35mVrms DAC typical resolution is $[9 - (-1.2)]/256 = 40\mu\text{V} = 28\mu\text{Vrms}$

### DetectTh2 Channel 2 Current Threshold in Detection Mode

Address: 12H Type: Read/Write Default Value: 0000H		
Bit	Name	Description
15:8	CalCodeN	Channel 2 current negative detector calculation code. Code mapping: 7'b000-0000, Vc = -1.2mV = -0.85mVrms (Vc is the threshold of low power computation) 7'b111-1111, Vc = 9mV = 6.35mVrms DAC typical resolution is $[9 - (-1.2)]/256 = 40\mu\text{V} = 28\mu\text{Vrms}$
7:0	CalCodeP	Channel 2 current positive detector calculation code. Code mapping: 7'b000-0000, Vc = -1.2mV = -0.85mVrms (Vc is the threshold of low power computation) 7'b111-1111, Vc = 9mV = 6.35mVrms DAC typical resolution is $[9 - (-1.2)]/256 = 40\mu\text{V} = 28\mu\text{Vrms}$

### DetectTh3 Channel 3 Current Threshold in Detection Mode

Address: 13H Type: Read/Write Default Value: 0000H		
Bit	Name	Description
15:8	CalCodeN	Channel 3 current negative detector calculation code. Code mapping: 7'b000-0000, Vc = -1.2mV = -0.85mVrms (Vc is the threshold of low power computation) 7'b111-1111, Vc = 9mV = 6.35mVrms DAC typical resolution is $[9 - (-1.2)]/256 = 40\mu\text{V} = 28\mu\text{Vrms}$
7:0	CalCodeP	Channel 3 current positive detector calculation code. Code mapping: 7'b000-0000, Vc = -1.2mV = -0.85mVrms (Vc is the threshold of low power computation) 7'b111-1111, Vc = 9mV = 6.35mVrms DAC typical resolution is $[9 - (-1.2)]/256 = 40\mu\text{V} = 28\mu\text{Vrms}$

## 5.3.2 PARTIAL MEASUREMENT MODE REGISTERS

**IDCOffsetA****Phase A Current DC offset**

Address: 14H Type: Read/Write Default Value: 0000H		
Bit	Name	Description
15:0	IDCOffsetA	Phase A current DC offset in decimator, signed with complement format.

**IDCOffsetB****Phase B Current DC offset**

Address: 15H Type: Read/Write Default Value: 0000H		
Bit	Name	Description
15:0	IDCOffsetB	Phase B current DC offset in decimator, signed with complement format.

**IDCOffsetC****Phase C Current DC offset**

Address: 16H Type: Read/Write Default Value: 0000H		
Bit	Name	Description
15:0	IDCOffsetC	Phase C current DC offset in decimator, signed with complement format.

**UDCOffsetA****Voltage DC offset for Channel A**

Address: 17H Type: Read/Write Default Value: 0000H		
Bit	Name	Description
15:0	UDCOffsetA	Phase A voltage DC offset in decimator, signed with complement format.

**UDCOffsetB****Voltage DC offset for Channel B**

Address: 18H Type: Read/Write Default Value: 0000H		
Bit	Name	Description
15:0	UDCOffsetB	Phase B voltage DC offset in decimator, signed with complement format.

**UDCoffsetC****Voltage DC offset for Channel C**

Address: 19H

Type: Read/Write

Default Value: 0000H

Bit	Name	Description
15:0	UDCoffsetC	Phase C voltage DC offset in decimator, signed with complement format.

**UGainTAB****Voltage Gain Temperature Compensation for Phase A/B**

Address: 1AH

Type: Read/Write

Default Value: 0000H

Bit	Name	Description
15:8	UGainTB	Voltage gain temperature compensation for phase B.
7:0	UGainTA	Voltage gain temperature compensation for phase A.

**UGainTC****Voltage Gain Temperature Compensation for Phase C**

Address: 1BH

Type: Read/Write

Default Value: 0000H

Bit	Name	Description
15:8	-	Reserved.
7:0	UGainTC	Voltage gain temperature compensation for phase C.

**PhiFreqComp****Phase Compensation for Frequency**

Address: 1CH

Type: Read/Write

Default Value: 0000H

Bit	Name	Description
15:8	-	Reserved.
7:0	PhiF	Phase compensation for frequency.

**LOGIrms0****Current (Log Irms0) Configuration for Segment Compensation**

Address: 20H

Type: Read/Write

Default Value: 0000H

Bit	Name	Description
15:8	-	Reserved.
7:0	LogIrms0	= $\log_2(I_{rms0})$ , $I_{rms0}$ is the nominal RMS current at calibration.

### LOGIrms1 Current (Log Irms1) Configuration for Segment Compensation

Address: 21H Type: Read/Write Default Value: 0000H		
Bit	Name	Description
15:8	-	Reserved.
7:0	LogIrms1	= $\log_2(I_{rms1})$ , $I_{rms1}$ is the nominal RMS current at calibration.

### F0 Nominal Frequency

Address: 22H Type: Read/Write Default Value: 5000		
Bit	Name	Description
15:0	F0	Nominal frequency. For example, 5000 corresponds to 50.00Hz.

### T0 Nominal Temperature

Address: 23H Type: Read/Write Default Value: 25		
Bit	Name	Description
15:8	-	Reserved.
7:0	T0	Signed, Nominal temperature in degree C.

### PhiArms01 Phase A Phase Compensation for Current Segment 0 and 1

Address: 24H Type: Read/Write Default Value: 0000H		
Bit	Name	Description
15:8	PhiArms1	Phase compensation for current segment 1 ( $I_{rms1} < I_{rms} < I_{rms0}$ ). Refer to <a href="#">3.9.2 Delay/Phase Based Compensation</a> .
7:0	PhiArms0	Phase compensation for current segment 0 ( $I_{rms} > I_{rms0}$ ). Refer to <a href="#">3.9.2 Delay/Phase Based Compensation</a> .

### PhiArms2 Phase A Phase Compensation for Current Segment 2

Address: 25H Type: Read/Write Default Value: 0000H		
Bit	Name	Description
15:8	-	Reserved.
7:0	PhiArms2	Phase compensation for current segment 2 ( $I_{rms} < I_{rms1}$ ). Refer to <a href="#">3.9.2 Delay/Phase Based Compensation</a> .

### GainAlrms01 Phase A Gain Compensation for Current Segment 0 and 1

Address: 26H Type: Read/Write Default Value: 0000H		
Bit	Name	Description
15:8	GainIrms1	Gain compensation for current segment 1 ( $I_{rms1} < I_{rms} < I_{rms0}$ ). Refer to <a href="#">3.9.1 Gain Based Compensation</a> .
7:0	GainIrms0	Gain compensation for current segment 0 ( $I_{rms} > I_{rms0}$ ). Refer to <a href="#">3.9.1 Gain Based Compensation</a> .

### GainAlrms2 Phase A Gain Compensation for Current Segment 2

Address: 27H Type: Read/Write Default Value: 0000H		
Bit	Name	Description
15:8	-	Reserved.
7:0	GainIrms2	Gain compensation for current segment 2 ( $I_{rms} < I_{rms1}$ ). Refer to <a href="#">3.9.1 Gain Based Compensation</a> .

### PhiBlrms01 Phase B Phase Compensation for Current Segment 0 and 1

Address: 28H Type: Read/Write Default Value: 0000H		
Bit	Name	Description
15:8	PhiIrms1	Phase compensation for current segment 1 ( $I_{rms1} < I_{rms} < I_{rms0}$ ). Refer to <a href="#">3.9.2 Delay/Phase Based Compensation</a> .
7:0	PhiIrms0	Phase compensation for current segment 0 ( $I_{rms} > I_{rms0}$ ). Refer to <a href="#">3.9.2 Delay/Phase Based Compensation</a> .

### PhiBlrms2 Phase B Phase Compensation for Current Segment 2

Address: 29H Type: Read/Write Default Value: 0000H		
Bit	Name	Description
15:8	-	Reserved.
7:0	PhiIrms2	Phase compensation for current segment 2 ( $I_{rms} < I_{rms1}$ ). Refer to <a href="#">3.9.2 Delay/Phase Based Compensation</a> .

### GainBlrms01 Phase B Gain Compensation for Current Segment 0 and 1

Address: 2AH Type: Read/Write Default Value: 0000H		
Bit	Name	Description
15:8	GainIrms1	Gain compensation for current segment 1 ( $I_{rms1} < I_{rms} < I_{rms0}$ ). Refer to <a href="#">3.9.1 Gain Based Compensation</a> .
7:0	GainIrms0	Gain compensation for current segment 0 ( $I_{rms} > I_{rms0}$ ). Refer to <a href="#">3.9.1 Gain Based Compensation</a> .

### GainIrms2 Phase B Gain Compensation for Current Segment 2

Address: 2BH Type: Read/Write Default Value: 0000H		
Bit	Name	Description
15:8	-	Reserved.
7:0	GainIrms2	Gain compensation for current segment 2 ( $I_{rms} < I_{rms1}$ ). Refer to <a href="#">3.9.1 Gain Based Compensation</a> .

### PhiClrms01 Phase C Phase Compensation for Current Segment 0 and 1

Address: 2CH Type: Read/Write Default Value: 0000H		
Bit	Name	Description
15:8	PhiIrms1	Phase compensation for current segment 1 ( $I_{rms1} < I_{rms} < I_{rms0}$ ). Refer to <a href="#">3.9.2 Delay/Phase Based Compensation</a> .
7:0	PhiIrms0	Phase compensation for current segment 0 ( $I_{rms} > I_{rms0}$ ). Refer to <a href="#">3.9.2 Delay/Phase Based Compensation</a> .

### PhiClrms2 Phase C Phase Compensation for Current Segment 2

Address: 2DH Type: Read/Write Default Value: 0000H		
Bit	Name	Description
15:8	-	Reserved.
7:0	PhiIrms2	Phase compensation for current segment 2 ( $I_{rms} < I_{rms1}$ ). Refer to <a href="#">3.9.2 Delay/Phase Based Compensation</a> .

### GainClrms01 Phase C Gain Compensation for Current Segment 0 and 1

Address: 2EH Type: Read/Write Default Value: 0000H		
Bit	Name	Description
15:8	GainIrms1	Gain compensation for current segment 1 ( $I_{rms1} < I_{rms} < I_{rms0}$ ). Refer to <a href="#">3.9.1 Gain Based Compensation</a> .
7:0	GainIrms0	Gain compensation for current segment 0 ( $I_{rms} > I_{rms0}$ ). Refer to <a href="#">3.9.1 Gain Based Compensation</a> .

### GainClrms2 Phase C Gain Compensation for Current Segment 2

Address: 2FH Type: Read/Write Default Value: 0000H		
Bit	Name	Description
15:8	-	Reserved.
7:0	GainIrms2	Gain compensation for current segment 2 ( $I_{rms} < I_{rms1}$ ). Refer to <a href="#">3.9.1 Gain Based Compensation</a> .

## 5.4 CONFIGURATION AND CALIBRATION REGISTERS

### 5.4.1 CONFIGURATION REGISTERS

Table-6 Configuration Registers

Register Address	Register Name	Read/Write Type	Functional Description	Power-on Value and Comments
<b>Configuration Registers</b>				
31H	PLconstH	R/W	High Word of PL_Constant	0861H
32H	PLconstL	R/W	Low Word of PL_Constant	C468H
33H	MMode0	R/W	HPF/Integrator On/Off, CF and all-phase energy computation configuration	0087H
34H	MMode1	R/W	Pga Gain Configuration	0000H
35H	PStartTh	R/W	Active Startup Power Threshold.	0000H. 16 bit unsigned integer, Unit: 0.00032 Watt
36H	QStartTh	R/W	Reactive Startup Power Threshold.	0000H 16 bit unsigned integer, Unit: 0.00032 var
37H	SStartTh	R/W	Apparent Startup Power Threshold.	0000H 16 bit unsigned integer, Unit: 0.00032 VA
38H	PPhaseTh	R/W	Startup power threshold (for $ P + Q $ of a phase) for any phase participating Active Energy Accumulation. Common for phase A/B/C.	0000H 16 bit unsigned integer, Unit: 0.00032 Watt/var
39H	QPhaseTh	R/W	Startup power threshold (for $ P + Q $ of a phase) for any phase participating ReActive Energy Accumulation. Common for phase A/B/C.	0000H 16bit unsigned integer, Unit: 0.00032 Watt/var
3AH	SPhaseTh	RW	Startup power threshold (for $ P + Q $ of a phase) for any phase participating Apparent Energy Accumulation. Common for phase A/B/C.	0000H 16 bit unsigned integer, Unit: 0.00032 Watt/var

#### PLconstH High Word of PL\_Constant

Address: 31H Type: Read/Write Default Value: 0861H		
Bit	Name	Description
15:0	PLconstH[15:0]	The PLconstH[15:0] and PLconstL[15:0] bits are high word and low word of PL_Constant respectively. PL_Constant is a constant which is proportional to the sampling ratios of voltage and current, and inversely proportional to the Meter Constant. PL_Constant is a threshold for energy calculated inside the chip, i.e., energy larger than PL_Constant will be accumulated as 0.01CFx in the corresponding energy registers and then output on CFx if one CF reaches. It is suggested to set PL_constant as a multiple of 4 so as to double or redouble Meter Constant in low current state to save verification time.

#### PLconstL Low Word of PL\_Constant

Address: 32H Type: Read/Write Default Value: C468H		
Bit	Name	Description
15:0	PLconstL[15:0]	The PLconstH[15:0] and PLconstL[15:0] bits are high word and low word of PL_Constant respectively. It is suggested to set PL_constant as a multiple of 4.

**MMode0**  
**Metering Method Configuration**

Address: 33H		
Type: Read/Write		
Default Value: 0087H		
Bit	Name	Description
15-13	-	Reserved.
12	Freq60Hz	Current Grid operating line frequency. 0: 50Hz (default) 1: 60Hz
11	HPFoff	Disable HPF in the signal processing path.
10	didtEn	Enable Integrator for didt current sensor. 0: disable (default) 1: enable
9	-	Reserved.
8	3P3W	This bit defines the voltage/current phase sequence detection mode: 0: 3P4W (default) 1: 3P3W (Ua is Uab, Uc is Ucb, Ub is not used)
7	CF2varh	CF2 pin source: 0: apparent energy 1: reactive energy (default)
6-5	-	Reserved.
4	ABSEnQ	These bits configure the calculation method of total (all-phase-sum) reactive/active energy and power: 0: Arithmetic sum: (default) ET=EA*EnPA+ EB*EnPB+ EC*EnPC PT= PA*EnPA+ PB*EnPB+ PC*EnPC 1: Absolute sum:
3	ABSEnP	ET= EA *EnPA+  EB *EnPB+  EC *EnPC PT= PA *EnPA+  PB *EnPB+  PC *EnPC Note: ET is the total (all-phase-sum) energy, EA/EB/EC are the signed phase A/B/C energy respectively. Reverse energy is negative. PT is the total (all-phase-sum) power, PA/PB/PC are the signed phase A/B/C power respectively. Reverse power is negative.
2	EnPA	These bits configure whether Phase A/B/C are counted into the all-phase sum energy/power (P/Q/S).
1	EnPB	1: Corresponding Phase A/B/C to be counted into the all-phase sum energy/power (P/Q/S) (default)
0	EnPC	0: Corresponding Phase A/B/C not counted into the all-phase sum energy/power (P/Q/S)



**MMode1**  
**PGA Gain Configuration**

Address: 34H		
Type: Read/Write		
Default Value: 0000H		
Bit	Name	Description
15-14	-	Reserved.
13-0	PGA_GAIN	PGA gain for all ADC channels.  Mapping: [13:12]: V3 [11:10]: V2 [9:8]: V1 [7:6]: - [5:4]: I3 [3:2]: I2 [1:0]: I1  Encoding: 00: 1X (default) 01: 2X 10: 4X 11: N/A

**5.4.2 ENERGY CALIBRATION REGISTERS**
**Table-7 Calibration Registers**

Register Address	Register Name	Read/Write Type	Functional Description	Power-on Value
<b>Calibration Registers</b>				
41H	PoffsetA	R/W	Phase A Active Power Offset	0000H
42H	QoffsetA	R/W	Phase A Reactive Power Offset	0000H
43H	PoffsetB	R/W	Phase B Active Power Offset	0000H
44H	QoffsetB	R/W	Phase B Reactive Power Offset	0000H
45H	PoffsetC	R/W	Phase C Active Power Offset	0000H
46H	QoffsetC	R/W	Phase C Reactive Power Offset	0000H
47H	GainA	R/W	Phase A Active/reactive Energy Calibration Gain	0000H
48H	PhiA	R/W	Phase A Calibration Phase Angle	0000H
49H	GainB	R/W	Phase B Active/reactive Energy Calibration Gain	0000H
4AH	PhiB	R/W	Phase B Calibration Phase Angle	0000H
4BH	GainC	R/W	Phase C Active/reactive Energy Calibration Gain	0000H
4CH	PhiC	R/W	Phase C Calibration Phase Angle	0000H

### PoffsetA Phase A Active Power offset

Address: 41H Type: Read/Write Default Value: 0000H		
Bit	Name	Description
15-0	offset	Phase A active power offset, signed with complement format.

### QoffsetA Phase A Reactive Power offset

Address: 42H Type: Read/Write Default Value: 0000H		
Bit	Name	Description
15-0	offset	Phase A reactive power offset, signed with complement format.

### GainA Phase A Active/Reactive Energy Calibration Gain

Address: 47H Type: Read/Write Default Value: 0000H		
Bit	Name	Description
15-0	Gain	Phase A energy gain, signed with complement format.

### PhiA Phase A Calibration Phase Angle

Address: 48H Type: Read/Write Default Value: 0000H		
Bit	Name	Description
15	DelayV	0: Delay Cycles are applied to current channel. (default) 1: Delay Cycles are applied to voltage channel.
14:8	-	Reserved.
7:0	DelayCycles	Number of delay cycles calculated in phase compensation. Unit is 2.048MHz cycle. It is an unsigned 8 bit integer.

## 5.4.3 FUNDAMENTAL/HARMONIC ENERGY CALIBRATION REGISTERS

Table-8 Fundamental/Harmonic Energy Calibration Registers

Register Address	Register Name	Read/Write Type	Functional Description	Power-on Value
51H	PoffsetAF	R/W	Phase A Fundamental Active Power offset	0000H
52H	PoffsetBF	R/W	Phase B Fundamental Active Power offset	0000H
53H	PoffsetCF	R/W	Phase C Fundamental Active Power offset	0000H
54H	PGainAF	R/W	Phase A Fundamental Calibration Gain	0000H
55H	PGainBF	R/W	Phase B Fundamental Calibration Gain	0000H
56H	PGainCF	R/W	Phase C Fundamental Calibration Gain	0000H

## 5.4.4 MEASUREMENT CALIBRATION

Table-9 Measurement Calibration Registers

Register Address	Register Name	Read/Write Type	Functional Description	Power-on Value
61H	UgainA	R/W	Phase A Voltage RMS Gain	8000H
62H	IgainA	R/W	Phase A Current RMS Gain	8000H
63H	UoffsetA	R/W	Phase A Voltage RMS offset	0000H
64H	IoffsetA	R/W	Phase A Current RMS offset	0000H
65H	UgainB	R/W	Phase B Voltage RMS Gain	8000H
66H	IgainB	R/W	Phase B Current RMS Gain	8000H
67H	UoffsetB	R/W	Phase B Voltage RMS offset	0000H
68H	IoffsetB	R/W	Phase B Current RMS offset	0000H
69H	UgainC	R/W	Phase C Voltage RMS Gain	8000H
6AH	IgainC	R/W	Phase C Current RMS Gain	8000H
6BH	UoffsetC	R/W	Phase C Voltage RMS offset	0000H
6CH	IoffsetC	R/W	Phase C Current RMS offset	0000H

## 5.4.5 EMM STATUS

Table-10 EMM Status Registers

Register Address	Register Name	Read/Write Type	Functional Description	Power-on Value
70H	<a href="#">SoftReset</a>	W	Software Reset	
71H	<a href="#">EMMState0</a>	R	EMM State 0	
72H	<a href="#">EMMState1</a>	R	EMM State 1	
73H	<a href="#">EMMIntState0</a>	R/W1C	EMM Interrupt Status 0	
74H	<a href="#">EMMIntState1</a>	R/W1C	EMM Interrupt Status 1	
75H	<a href="#">EMMIntEn0</a>	R/W	EMM Interrupt Enable 0	
76H	<a href="#">EMMIntEn1</a>	R/W	EMM Interrupt Enable 1	
78H	<a href="#">LastSPIData</a>	R/W1C	Last Read/Write SPI Value	
79H	<a href="#">CRCErrStatus</a>	R	CRC Error Status	
7AH	<a href="#">CRCDigest</a>	R/W	CRC Digest	
7FH	<a href="#">CfgRegAccEn</a>	R/W	Configure Register Access Enable	

**SoftReset**  
**Software Reset**

Address: 70H  
 Type: Write  
 Default Value: 0000H

Bit	Name	Description
15:0	SoftReset[15:0]	Software reset register. The 90E32AS resets if 789AH is written to this register. The reset domain is the same as the $\overline{\text{RESET}}$ pin or Power On Reset. Reading this register always return 0.

**EMMState0**  
**EMM State 0**

Address: 71H  
 Type: Read  
 Default Value: 0000H

Bit	Name	Description
15	OIPhaseAST	Set to 1: if there is over current on phase A
14	OIPhaseBST	Set to 1: if there is over current on phase B
13	OIPhaseCST	Set to 1: if there is over current on phase C
12	OVPhaseAST	Set to 1: if there is over voltage on phase A
11	OVPhaseBST	Set to 1: if there is over voltage on phase B
10	OVPhaseCST	Set to 1: if there is over voltage on phase C
9	URevWnST	Voltage Phase Sequence Error status
8	IRevWnST	Current Phase Sequence Error status
7	INOV0ST	When the calculated N line current is greater than the threshold set by the INWarnTh register, this bit is set.
6	TQNoloadST	All phase sum reactive power no-load condition status
5	TPNoloadST	All phase sum active power no-load condition status
4	TASNoloadST	All phase arithmetic sum apparent power no-load condition status
3	CF1RevST	Energy for CF1 Forward/Reverse status: 0: Forward 1: Reverse
2	CF2RevST	Energy for CF2 Forward/Reverse status: 0: Forward 1: Reverse
1	CF3RevST	Energy for CF3 Forward/Reverse status: 0: Forward 1: Reverse
0	CF4RevST	Energy for CF4 Forward/Reverse status: 0: Forward 1: Reverse

**EMMState1**  
**EMM State 1**

Address: 72H  
 Type: Read  
 Default Value: 0000H

Bit	Name	Description
15	FreqHiST	This bit indicates whether frequency is greater than the high threshold
14	SagPhaseAST	This bit indicates whether there is voltage sag on phase A
13	SagPhaseBST	This bit indicates whether there is voltage sag on phase B
12	SagPhaseCST	This bit indicates whether there is voltage sag on phase C
11	FreqLoST	This bit indicates whether frequency is lesser than the low threshold
10	PhaseLossAST	This bit indicates whether there is a phase loss in Phase A
9	PhaseLossBST	This bit indicates whether there is a phase loss in Phase B
8	PhaseLossCST	This bit indicates whether there is a phase loss in Phase C
7	QERegTPST	ReActive (Q) Energy (E) Register (Reg) of all channel total sum (T) Positive (P) Status (ST): 0: Positive, 1: Negative
6	QERegAPST	ReActive (Q) Energy (E) Register (Reg) of Channel (A/B/C) Positive (P) Status (ST): 0: Positive, 1: Negative
5	QERegBPST	
4	QERegCPST	
3	PERegTPST	Active (P) Energy (E) Register (Reg) of all channel total sum (T) Positive (P) Status (ST) 0: Positive, 1: Negative
2	PERegAPST	Active (P) Energy (E) Register (Reg) of Channel (A/B/C) Positive (P) Status (ST) 0: Positive, 1: Negative
1	PERegBPST	
0	PERegCPST	

**EMMIntState0**  
**EMM Interrupt Status 0**

Address: 73H  
 Type: Read/ Write 1 Clear  
 Default Value: 0000H

Bit	Name	Description
15	OIPhaseAIntST	Over current on phase A status change flag
14	OIPhaseBIntST	Over current on phase B status change flag
13	OIPhaseCIntST	Over current on phase C status change flag
12	OVPhaseAIntST	Over Voltage on phase A status change flag

11	OVPhaseBIntST	Over Voltage on phase B status change flag
10	OVPhaseCIntST	Over Voltage on phase C status change flag
9	URevWnIntST	Voltage Phase Sequence Error status change flag
8	IRevWnIntST	Current Phase Sequence Error status change flag
7	INOV0IntST	Neutral line over current status change flag
6	TQNoloadIntST	All phase sum reactive power no-load condition status change flag
5	TPNoloadIntST	All phase sum active power no-load condition status change flag
4	TASNoloadIntST	All phase arithmetic sum apparent power no-load condition status change flag
3	CF1RevIntST	Energy for CF1 Forward/Reverse status change flag
2	CF2RevIntST	Energy for CF2 Forward/Reverse status change flag
1	CF3RevIntST	Energy for CF3 Forward/Reverse status change flag
0	CF4RevIntST	Energy for CF4 Forward/Reverse status change flag

### EMMIntState1 EMM Interrupt Status 1

Address: 74H		
Type: Read/ Write 1 Clear		
Default Value: 0000H		
Bit	Name	Description
15	FreqHiIntST	FreqHiST change flag
14	SagPhaseAIntST	Voltage sag on phase A status change flag
13	SagPhaseBIntST	Voltage sag on phase B status change flag
12	SagPhaseCIntST	Voltage sag on phase C status change flag
11	FreqLoIntST	FreqLoST change flag
10	PhaseLoss-AIntST	Voltage PhaseLoss on phase A status change flag
9	PhaseLoss-BIntST	Voltage PhaseLoss on phase B status change flag
8	PhaseLoss-CIntST	Voltage PhaseLoss on phase C status change flag
7	QERegTPIntST	ReActive (Q) Energy (E) Register (Reg) of all channel total sum (T) Positive (P) status change flag (IntST)
6	QERegAPIntST	ReActive (Q) Energy (E) Register (Reg) of all channel (A/B/C) Positive (P) status change flag (IntST)
5	QERegBPIntST	
4	QERegCPIntST	
3	PERegTPIntST	Active (P) Energy (E) Register (Reg) of all channel total sum (T) Positive (P) status change flag (IntST)
2	PERegAPIntST	Active (P) Energy(E) Register (Reg) of Channel (A/B/C) Positive (P) status change flag (IntST)
1	PERegBPIntST	
0	PERegCPIntST	

**EMMIntEn0**  
**EMM Interrupt Enable 0**

Address: 75H  
 Type: Read/ Write  
 Default Value: 0000H

Bit	Name	Description
15	OIPhaseAIntEN	Phase A Over current status change interrupt generation enable
14	OIPhaseBIntEN	Phase B Over current status change interrupt generation enable
13	OIPhaseCIntEN	Phase C Over current status change interrupt generation enable
12	OVPPhaseAIntEN	Phase A Over Voltage status change interrupt generation enable
11	OVPPhaseBIntEN	Phase B Over Voltage status change interrupt generation enable
10	OVPPhaseCIntEN	Phase C Over Voltage status change interrupt generation enable
9	URevWnIntEN	Voltage Phase Sequence Error Status Change Interrupt Generation Enable
8	IRevWnIntEN	Current Phase Sequence Error Status Change Interrupt Generation Enable
7	INOv0IntEN	Neutral line over current Status Change Interrupt Generation Enable
6	TQNoloadIntEN	All phase sum reactive power no-load condition Status Change Interrupt Generation Enable
5	TPNoloadIntEN	All phase sum active power no-load condition Status Change Interrupt Generation Enable
4	TASNoloadIntEN	All phase arithmetic sum apparent power no-load condition Status Change Interrupt Generation Enable
3	CF1RevIntEN	Energy for CF1 Forward/Reverse Status Change Interrupt Generation Enable
2	CF2RevIntEN	Energy for CF2 Forward/Reverse Status Change Interrupt Generation Enable
1	CF3RevIntEN	Energy for CF3 Forward/Reverse Status Change Interrupt Generation Enable
0	CF4RevIntEN	Energy for CF4 Forward/Reverse Status Change Interrupt Generation Enable

### EMMIntEn1 EMM Interrupt Enable 1

Address: 76H		
Type: Read/ Write		
Default Value: 0000H		
Bit	Name	Description
15	FreqHiIntEn	FreqHiIntST status change interrupt generation enable
14	SagPhaseAIntEN	Phase A Sag status change interrupt generation enable
13	SagPhaseBIntEN	Phase B Sag status change interrupt generation enable
12	SagPhaseCIntEN	Phase C Sag status change interrupt generation enable
11	FreqLoIntEn	FreqLoIntST status change interrupt generation enable
10	PhaseLossAIntEN	Phase A Phase Loss status change interrupt generation enable
9	PhaseLossBIntEN	Phase B Phase Loss status change interrupt generation enable
8	PhaseLossCIntEN	Phase C Phase Loss status change interrupt generation enable
7	QERegTPIntEN	ReActive (Q) Energy(E) Register (Reg) of all channel total sum (T) Positive (P) Status Change Interrupt Generation Enable (IntEN)
6	QERegAPIntEN	
5	QERegBPIntEN	
4	QERegCPIntEN	
3	PERegTPIntEN	Active (P) Energy (E) Register (Reg) of Channel A (A) Positive (P) Status Change Interrupt Generation Enable (ST)
2	PERegAPIntEN	
1	PERegBPIntEN	
0	PERegCPIntEN	

### LastSPIData Last Read/Write SPI Value

Address: 78H		
Type: Read		
Default Value: 0000H		
Bit	Name	Description
15:0	LastSPI-Data[15:0]	This register is a special register which logs data of the previous SPI Read or Write access especially for Read/Clear registers. This register is useful when the user wants to check the integrity of the last SPI access.

### CRCErrStatus CRC Error Status

Address: 79H		
Type: Read		
Default Value: 0000H		
Bit	Name	Description
15:2	-	Reserved.
1	INT_ERR	Internal register CRC error
0	CFG_CRC_ERR	Configuration registers CRC error



### CRCDigest CRC Digest

Address: 7AH  
Type: Read/ Write  
Default Value: 0000H

Bit	Name	Description
15:0	CRCDigest	This register returns the computed CRC remainder (Digest) value of the public configuration register upon read operation. This register can be conditionally written as the portal to update the golden CRC that internally latched. Refer to register <a href="#">CfgRegAccEn</a> for the details.

### CfgRegAccEn Configure Register Access Enable

Address: 7FH  
Type: Read/ Write  
Default Value: 0000H

Bit	Name	Description
15:0	CfgRegAccEn	Enable register access configuration. '0x55AA': Allow register configuration access (configuration operation). '0xAA55': Allow write to the "Golden CRC" register at the address of CRCDigest, on top of normal operation/CRC checking mode. This is just for validation of this feature. other: Normal operation. The device will start to compute a CRC digest/checksum and latch it the golden CRC register, then continuously running to check with it.

## 5.5 ENERGY REGISTER

### 5.5.1 REGULAR ENERGY REGISTERS

Table-11 Regular Energy Registers

Register Address	Register Name	Read/Write Type	Functional Description	Comment
80H	APenergyT	R/C	Total Forward Active Energy	Resolution is 0.01CF. Cleared after read.
81H	APenergyA	R/C	Phase A Forward Active Energy	
82H	APenergyB	R/C	Phase B Forward Active Energy	
83H	APenergyC	R/C	Phase C Forward Active Energy	
84H	ANenergyT	R/C	Total Reverse Active Energy	
85H	ANenergyA	R/C	Phase A Reverse Active Energy	
86H	ANenergyB	R/C	Phase B Reverse Active Energy	
87H	ANenergyC	R/C	Phase C Reverse Active Energy	
88H	RPenergyT	R/C	Total Forward Reactive Energy	
89H	RPenergyA	R/C	Phase A Forward Reactive Energy	
8AH	RPenergyB	R/C	Phase B Forward Reactive Energy	
8BH	RPenergyC	R/C	Phase C Forward Reactive Energy	
8CH	RNenergyT	R/C	Total Reverse Reactive Energy	
8DH	RNenergyA	R/C	Phase A Reverse Reactive Energy	
8EH	RNenergyB	R/C	Phase B Reverse Reactive Energy	
8FH	RNenergyC	R/C	Phase C Reverse Reactive Energy	
90H	SAenergyT	R/C	Total (Arithmetic Sum) Apparent Energy	
91H	SenenergyA	R/C	Phase A Apparent Energy	
92H	SenenergyB	R/C	Phase B Apparent Energy	
93H	SenenergyC	R/C	Phase C Apparent Energy	

## 5.5.2 FUNDAMENTAL / HARMONIC ENERGY REGISTER

Table-12 Fundamental / Harmonic Energy Register

Register Address	Register Name	Read/Write Type	Functional Description	Comment
A0H	APenergyTF	R/C	Total Forward Active Fundamental Energy	Resolution is 0.01CF. Cleared after read.
A1H	APenergyAF	R/C	Phase A Forward Active Fundamental Energy	
A2H	APenergyBF	R/C	Phase B Forward Active Fundamental Energy	
A3H	APenergyCF	R/C	Phase C Forward Active Fundamental Energy	
A4H	ANenergyTF	R/C	Total Reverse Active Fundamental Energy	
A5H	ANenergyAF	R/C	Phase A Reverse Active Fundamental Energy	
A6H	ANenergyBF	R/C	Phase B Reverse Active Fundamental Energy	
A7H	ANenergyCF	R/C	Phase C Reverse Active Fundamental Energy	
A8H	APenergyTH	R/C	Total Forward Active Harmonic Energy	
A9H	APenergyAH	R/C	Phase A Forward Active Harmonic Energy	
AAH	APenergyBH	R/C	Phase B Forward Active Harmonic Energy	
ABH	APenergyCH	R/C	Phase C Forward Active Harmonic Energy	
ACH	ANenergyTH	R/C	Total Reverse Active Harmonic Energy	
ADH	ANenergyAH	R/C	Phase A Reverse Active Harmonic Energy	
AEH	ANenergyBH	R/C	Phase B Reverse Active Harmonic Energy	
AFH	ANenergyCH	R/C	Phase C Reverse Active Harmonic Energy	

## 5.6 MEASUREMENT REGISTERS

### 5.6.1 POWER AND POWER FACTOR REGISTERS

Table-13 Power and Power Factor Register

Register Address	Register Name	Read/Write Type	Functional Description	Comment
B0H	PmeanT	R	Total (All-phase-sum) Active Power	Complement, Power=32-bit register value* 0.00032 W
B1H	PmeanA	R	Phase A Active Power	
B2H	PmeanB	R	Phase B Active Power	
B3H	PmeanC	R	Phase C Active Power	
B4H	QmeanT	R	Total (All-phase-sum) Reactive Power	Complement, Power=32-bit register value* 0.00032 var
B5H	QmeanA	R	Phase A Reactive Power	
B6H	QmeanB	R	Phase B Reactive Power	
B7H	QmeanC	R	Phase C Reactive Power	
B8H	SAmeanT	R	Total (Arithmetic Sum) Apparent Power	Complement, Power=32-bit register value* 0.00032 VA
B9H	SmeanA	R	Phase A Apparent Power	
BAH	SmeanB	R	Phase B Apparent Power	
BBH	SmeanC	R	Phase C Apparent Power	
BCH	PFmeanT	R	Total Power Factor	Signed with complement format, X.XXX LSB is 0.001. Range from -1000 to +1000
BDH	PFmeanA	R	Phase A Power Factor	
BEH	PFmeanB	R	Phase B Power Factor	
BFH	PFmeanC	R	Phase C Power Factor	
C0H	PmeanTL SB	R	Lower Word of Total (All-phase-sum) Active Power	Lower word of Active Powers.
C1H	PmeanAL SB	R	Lower Word of Phase A Active Power	Lower word of Active Powers.
C2H	PmeanBL SB	R	Lower Word of Phase B Active Power	
C3H	PmeanCL SB	R	Lower Word of Phase C Active Power	
C4H	QmeanTL SB	R	Lower Word of Total (All-phase-sum) Reactive Power	Lower word of ReActive Powers.
C5H	QmeanAL SB	R	Lower Word of Phase A Reactive Power	Lower word of ReActive Powers.
C6H	QmeanBL SB	R	Lower Word of Phase B Reactive Power	
C7H	QmeanCL SB	R	Lower Word of Phase C Reactive Power	
C8H	SAmeanTL SB	R	Lower Word of Total (Arithmetic Sum) Apparent Power	Lower word of Apparent Powers.
C9H	SmeanAL SB	R	Lower Word of Phase A Apparent Power	Lower word of Apparent Powers.
CAH	SmeanBL SB	R	Lower Word of Phase B Apparent Power	
CBH	SmeanCL SB	R	Lower Word of Phase C Apparent Power	

Note: The power registers are all of 32-bit. The C0H~CBH registers are the lower words of the B0H~BFH registers.

### 5.6.2 FUNDAMENTAL/ HARMONIC POWER AND VOLTAGE/ CURRENT RMS REGISTERS

Table-14 Fundamental/ Harmonic Power and Voltage/ Current RMS Registers

Register Address	Register Name	Read/Write Type	Functional Description	Comment
D0H	PmeanTF	R	Total Active Fundamental Power	Complement, Power=32-bit register value* 0.00032 W

Table-14 Fundamental/ Harmonic Power and Voltage/ Current RMS Registers

Register Address	Register Name	Read/Write Type	Functional Description	Comment
D1H	PmeanAF	R	Phase A Active Fundamental Power	Complement, Power=32-bit register value* 0.00032 W
D2H	PmeanBF	R	Phase B Active Fundamental Power	
D3H	PmeanCF	R	Phase C Active Fundamental Power	
D4H	PmeanTH	R	Total Active Harmonic Power	Complement, Power=32-bit register value* 0.00032 W
D5H	PmeanAH	R	Phase A Active Harmonic Power	Complement, Power=32-bit register value* 0.00032 W
D6H	PmeanBH	R	Phase B Active Harmonic Power	
D7H	PmeanCH	R	Phase C Active Harmonic Power	
D9H	UrmsA	R	Phase A Voltage RMS	Unsigned, 1LSB corresponds to 0.01 V
DAH	UrmsB	R	Phase B Voltage RMS	
DBH	UrmsC	R	Phase C Voltage RMS	
DCH	IrmsN	R	N Line Calculated Current RMS	Unsigned 16-bit integer with unit of 0.001A 1LSB corresponds to 0.001 A
DDH	IrmsA	R	Phase A Current RMS	
DEH	IrmsB	R	Phase B Current RMS	
DFH	IrmsC	R	Phase C Current RMS	
E0H	PmeanTFLSB	R	Lower Word of Total Active Fundamental Power	Lower word of D0H register.
E1H	PmeanAFLSB	R	Lower Word of Phase A Active Fundamental Power	Lower word of registers from D1H to D3H.
E2H	PmeanBFLSB	R	Lower Word of Phase B Active Fundamental Power	
E3H	PmeanCFLSB	R	Lower Word of phase C active fundamental Power	
E9H	UrmsALSB	R	Lower Word of Phase A Voltage RMS	Lower word of registers from D9H to DBH.
EAH	UrmsBLSB	R	Lower Word of Phase B Voltage RMS	
EBH	UrmsCLSB	R	Lower Word of Phase C Voltage RMS	
EDH	IrmsALSB	R	Lower Word of Phase A Current RMS	Lower word of registers from DDH to DFH.
EEH	IrmsBLSB	R	Lower Word of Phase B Current RMS	
EFH	IrmsCLSB	R	Lower Word of Phase C Current RMS	

Note: The power registers are all of 32-bit. The E0H-EFH registers are the lower words of the D0H-DFH registers.

### 5.6.3 PEAK, FREQUENCY, ANGLE AND TEMPERATURE REGISTERS

Table-15 Peak, Frequency, Angle and Temperature Registers

Register Address	Register Name	Read/Write Type	Functional Description	Comment
F1H	UPeakA	R	Channel A Voltage Peak	
F2H	IPeakA	R	Channel A Current Peak	
F3H	UPeakB	R	Channel B Voltage Peak	
F5H	IPeakB	R	Channel B Current Peak	
F6H	UPeakC	R	Channel C Voltage Peak	
F7H	IPeakC	R	Channel C Current Peak	
F8H	Freq	R	Frequency	1LSB corresponds to 0.01 Hz

Table-15 Peak, Frequency, Angle and Temperature Registers

Register Address	Register Name	Read/Write Type	Functional Description	Comment
F9H	PAngleA	R	Phase A Mean Phase Angle	Unsigned, 1LSB corresponds to 0.1 degree, 0°~+360.0°
FAH	PAngleB	R	Phase B Mean Phase Angle	
FBH	PAngleC	R	Phase C Mean Phase Angle	
FCH	Temp	R	Measured Temperature	1LSB corresponds to 1 °C Signed, MSB as the sign bit
FDH	UangleA	R	Phase A Voltage Phase Angle	Always '0'
FEH	UangleB	R	Phase B Voltage Phase Angle	Unsigned, 1LSB corresponds to 0.1 degree, 0°~+360.0°
FFH	UangleC	R	Phase C Voltage Phase Angle	

### UPeakA Channel A Voltage Peak

Address: F1H  
Type: Read  
Default Value: 0000H

Bit	Name	Description
15:0	UPeakDataA	<p>Channel A voltage peak data detected in the configured period. Component. Unit is V. UPeak is calculated as below:</p> $UPeak = UPeakRegValue \times \frac{UgainRegValue}{100 \times 2^{13}}$ <p>Here UgainRegValue is the register value of the Ugain (61H/65H/69H) register.</p>

### IPeakA Channel A Current Peak

Address: F5H  
Type: Read  
Default Value: 0000H

Bit	Name	Description
15:0	IPeakDataA	<p>Channel A current peak data detected in the configured period. Component. Unit is A. IPeak is calculated as below:</p> $IPeak = IPeakRegValue \times \frac{IgainRegValue}{1000 \times 2^{13}}$ <p>Here IgainRegValue is the register value of the Igain (62H/66H/6AH) register.</p>

## 6 ELECTRICAL SPECIFICATION

### 6.1 ELECTRICAL SPECIFICATION

Parameter	Min	Typ	Max	Unit	Test Condition/ Comments
<b>Accuracy</b>					
DC Power Supply Rejection Ratio (PSRR)			±0.1	%	VDD=3.3V±0.3V, I=5A, V=220V, CT 1000:1, sampling resistor 4.8Ω
AC Power Supply Rejection Ratio (PSRR)			±0.1	%	VDD=3.3V superimposes 400mVrms, I=5A, V=220V, CT 1000:1, sampling resistor 4.8Ω
Active Energy Error (Dynamic Range 6000:1)			±0.1	%	CT 1000:1, sampling resistor 4.8Ω
<b>ADC Channel</b>					
Channel Differential Input	120μ		720m	Vrms	PGA=1 <sup>note1</sup>
Voltage Channel Input Impedance		120		KΩ	PGA=1
Current Channel Input Impedance		120		KΩ	PGA=1
		80			PGA=2
		50			PGA=4
Channel Sampling Frequency		8		kHz	
Channel Sampling Bandwidth		2		kHz	
<b>Temperature Sensor and Reference</b>					
Temperature Sensor Accuracy		1		°C	
Reference voltage		1.2		V	3.3 V, 25 °C
Reference voltage temperature coefficient		6	15	ppm/°C	From -40 to 85 °C
<b>Current detectors</b>					
Current Detector threshold range	1.5		4	mVrms	3.3 V, 25 °C
Current Detector threshold setting step/ resolution		0.05		mVrms	3.3 V, 25 °C
Current Detector detection time (single-side)	32			ms	
Current Detector detection time (double-side)	17			ms	
<b>Crystal Oscillator</b>					
Oscillator Frequency (f <sub>sys_clk</sub> )		16.384		MHz	The Accuracy of crystal or external clock is ±20 ppm, 10pF ~ 20pF crystal load capacitor integrated.
<b>Power Supply</b>					
AVDD	2.8	3.3	3.6	V	
DVDD	2.8	3.3	3.6	V	
VDD18		1.8		V	
<b>Operating Currents</b>					
Normal mode operating current (I-Normal)		13		mA	3.3 V, 25 °C
Idle mode operating current (I-Idle)		<0.1	1	μA	
Detection mode operating current (I-Detection)		200	230	μA	Double-side detection
		100	115		Single-side detection
Partial Measurement mode operating current (I-Measurement)		7		mA	3.3 V, 25 °C
<b>SPI</b>					
Slave mode (SPI) bit rate	400		1100k <sup>note 2</sup>	bps	
<b>ESD</b>					
Machine Model (MM)	400			V	JESD22-A115
Charged Device Model (CDM)	1000			V	JESD22-C101
Human Body Model (HBM)	6000			V	JESD22-A114
Latch Up			±100	mA	JESD78A
Latch Up			5.4	V	JESD78A
<b>DC Characteristics</b>					
Digital Input High Level (all digital pins except OSC1)	2.0		5.5	V	VDD=3.3V, 5V digital input compatible
Digital Input Low Level (all digital pins except OSC1)			0.8	V	VDD=3.3V
Digital Input Leakage Current			±1	μA	VDD=3.6V, VI=VDD or GND

Parameter	Min	Typ	Max	Unit	Test Condition/ Comments
Digital Output Low Level (CF1, CF2, CF3, CF4, ZX0, ZX1, ZX2, SDO)			0.4	V	VDD=3.3V, I <sub>OL</sub> =8mA
Digital Output Low Level (IRQ0, IRQ1, WarnOut)			0.4	V	VDD=3.3V, I <sub>OL</sub> =5mA
Digital Output High Level (CF1, CF2, CF3, CF4, ZX0, ZX1, ZX2, SDO)	VDD-0.4			V	VDD=3.3V, I <sub>OH</sub> =-8mA, by separately
Digital Output High Level (IRQ0, IRQ1, WarnOut)	VDD-0.4			V	VDD=3.3V, I <sub>OH</sub> =-5mA, by separately
note1: Guaranteed by design or characterization, not production tested.					
note2: The maximum SPI bit rate during current detector calibration is 900k bps.					



## 6.2 METERING/ MEASUREMENT ACCURACY

### 6.2.1 METERING ACCURACY

Metering accuracy or energy accuracy is calculated with relative error:

$$\gamma = \frac{E_{mea} - E_{real}}{E_{real}} \times 100\%$$

Where  $E_{mea}$  is the energy measured by the meter,  $E_{real}$  is the actual energy measured by a high accurate normative meter.

**Table-16 Metering Accuracy for Different Energy within the Dynamic Range**

Energy Type	Energy Pulse	ADC Range When Gain=1	Metering Accuracy <sup>note 1</sup>
Active energy (Per phase and all-phase-sum)	CF1	PF=1.0 120 $\mu$ V-720mV	0.1%
		PF=0.5L, 180 $\mu$ V-720mV	
		PF=0.8C, 150 $\mu$ V-720mV	
Reactive energy (Per phase and all-phase-sum)	CF2	sin $\Phi$ =1.0 120 $\mu$ V-720mV	0.2%
		sin $\Phi$ =0.5L, 180 $\mu$ V-720mV	
		sin $\Phi$ =0.8C, 150 $\mu$ V-720mV	
Apparent energy (Per phase and arithmetic all-phase-sum)	CF2	600 $\mu$ V-720mV <sup>note 2</sup>	0.2%
Fundamental active energy (Per phase and all-phase-sum)	CF3	PF=1.0 120 $\mu$ V-720mV	0.2%
		PF=0.5L, 180 $\mu$ V-720mV	
		PF=0.8C, 150 $\mu$ V-720mV	
Harmonic active energy (Per phase and all-phase-sum)	CF4	PF=1.0 120 $\mu$ V-720mV	0.5%
		PF=0.5L, 180 $\mu$ V-720mV	
		PF=0.8C, 150 $\mu$ V-720mV	

Note 1: All the parameters in this table is tested on Atmel test platform.

Note 2: Apparent energy is tested using active energy with unity power factor since there's no standard for apparent energy. Signal below 600  $\mu$ V is not tested.

### 6.2.2 MEASUREMENT ACCURACY

The measurements are all calculated with fiducial error except for frequency.

Fiducial error is calculated as follows:

$$\text{Fiducial\_Error} = \frac{U_{\text{mea}} - U_{\text{real}}}{U_{\text{FV}}} * 100\%$$

Where  $U_{\text{mea}}$  means the measured data of one measurement parameter, and  $U_{\text{real}}$  means the real/actual data of the parameter,

$U_{\text{FV}}$  means the fiducial value of this measurement parameter, which can be defined as [Table-17](#).

**Table-17 Measurement Parameter Range and Format**

Measurement	Fiducial Value (FV)	90E32AS Defined Format	Range	Comment
Voltage	reference voltage $U_n$	XXX.XX	0 ~ 655.35V	Unsigned integer with unit of 0.01V
Current	maximum current $I_{\text{max}}$ ( $4 \times I_n$ is recommended)	XX.XXX	0 ~ 65.535A	Unsigned integer with unit of 0.001A
Voltage rms	$U_n$	XXX.XX	0 ~ 655.35V	Unsigned integer with unit of 0.01V
Current rms <sup>note 1</sup>	$I_b/I_n$	XX.XXX	0 ~ 65.535A	Unsigned integer with unit of 0.001A
Frequency	Reference Frequency 50 Hz	XX.XX	45.00~65.00 Hz	Signed integer with unit/LSB of 0.01Hz
Power Factor	1.000	X.XXX	-1.000 ~ +1.000	Signed integer, LSB/Unit = 0.001
Phase Angle <sup>note 2</sup>	180°	XXX.X	-180° ~ +180°	Signed integer, unit/LSB = 0.1°

Note 1:

All registers are of 16-bit. For cases when the current or active/reactive/apparent power goes beyond the above range, it is suggested to be handled by MCU in application. For example, register value can be calibrated to 1/2 of the actual value during calibration, then multiply 2 in application.

Note 2:

Phase angle is obtained when voltage/current crosses zero at the sampling frequency of 256kHz.

For the above mentioned parameters, the measurement accuracy requirement is 0.5% maximum.

For frequency, temperature,:

Parameter Accuracy

Frequency: 0.01Hz

Temperature: 1 °C

Accuracy of all orders of harmonics: 5% relative error

## 6.3 INTERFACE TIMING

### 6.3.1 SPI INTERFACE TIMING (SLAVE MODE)

The SPI interface timing is as shown in Figure-22 and Table-18.

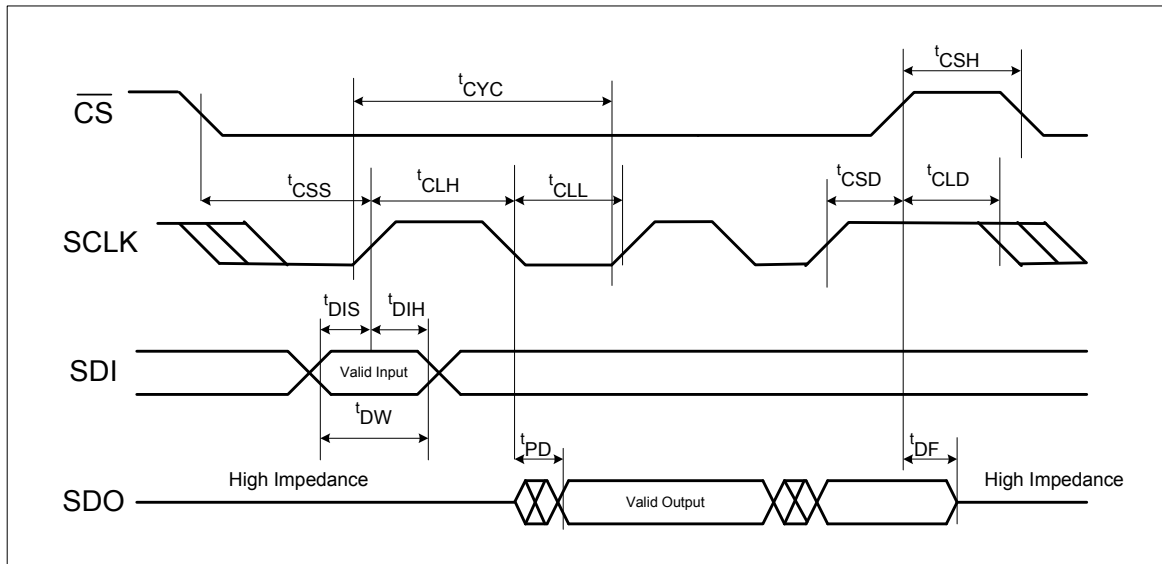

Figure-22 SPI Timing Diagram

Table-18 SPI Timing Specification

Symbol	Description	Min.	Typical	Max.	Unit
$t_{CSH}$	Minimum $\overline{CS}$ High Level Time	$2T^{note\ 1} + 10$			ns
$t_{CSS}$	$\overline{CS}$ Setup Time	$2T + 10$			ns
$t_{CSD}$	$\overline{CS}$ Hold Time	$3T + 10$			ns
$t_{CLD}$	Clock Disable Time	$1T$			ns
$t_{CYC}$	SCLK cycle	$7T + 10$			ns
$t_{CLH}$	Clock High Level Time	$5T + 10$			ns
$t_{CLL}$	Clock Low Level Time	$2T + 10$			ns
$t_{DIS}$	Data Setup Time	$2T + 10$			ns
$t_{DIH}$	Data Hold Time	$1T + 10$			ns
$t_{DW}$	Minimum Data Width	$3T + 10$			ns
$t_{PD}$	Output Delay			$2T + 20$	ns
$t_{DF}$	Output Disable Time			$2T + 20$	ns

**Note:**

1. T means system clock cycle.  $T = 1/f_{sys\_clk}$

### 6.4 POWER ON RESET TIMING

In most case, the power of 90E32AS and MCU are both derived from 220V power lines. To make sure 90E32AS is reset and can work properly, MCU must force 90E32AS into idle mode firstly and then into nor-

mal mode. In this operation,  $\overline{\text{RESET}}$  is held to high in idle mode and de-asserted by delay  $T_1$  after idle-normal transition. Refer to [Figure-23](#).

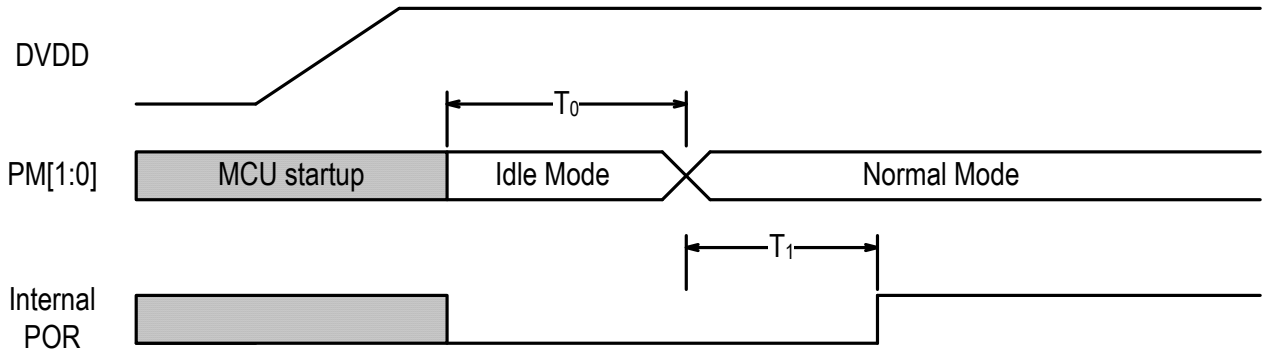

**Figure-23 Power On Reset Timing (90E32AS and MCU are Powered on Simultaneously)**

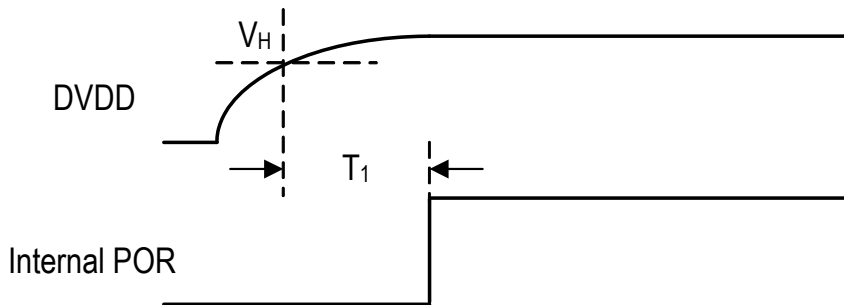
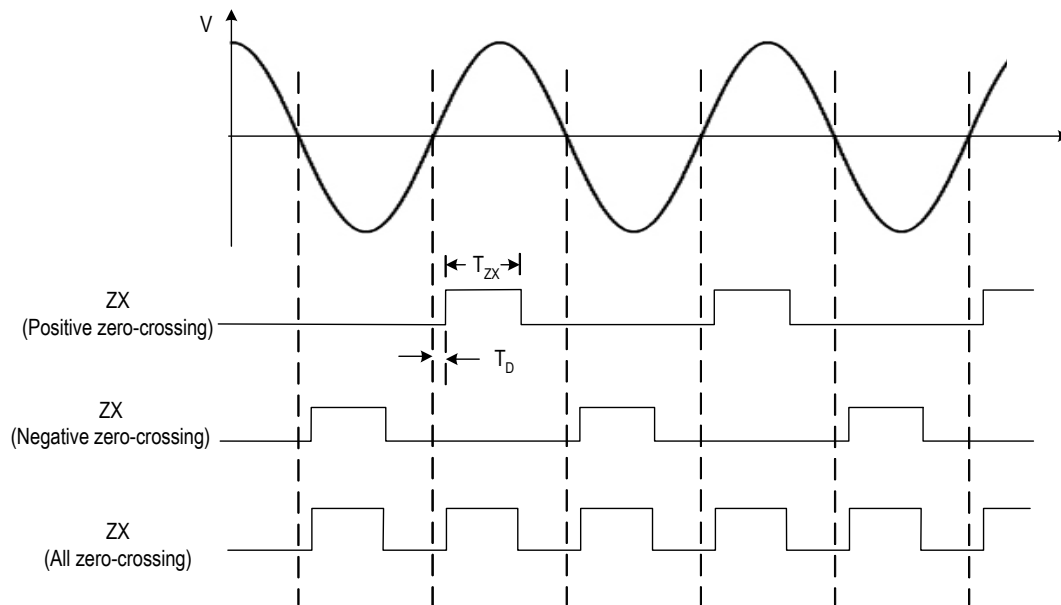

**Figure-24 Power On Reset Timing in Normal & Partial Measurement Mode**

**Table-19 Power On Reset Specification**

Symbol	Description	Min	Typ	Max	Unit
$V_H$	Power On Trigger Voltage		2.5	2.7	V
$T_0$	Duration forced in idle mode after power on	1			ms
$T_1$	Delay time after power on or exit idle mode	5	16	40	ms

## 6.5 ZERO-CROSSING TIMING

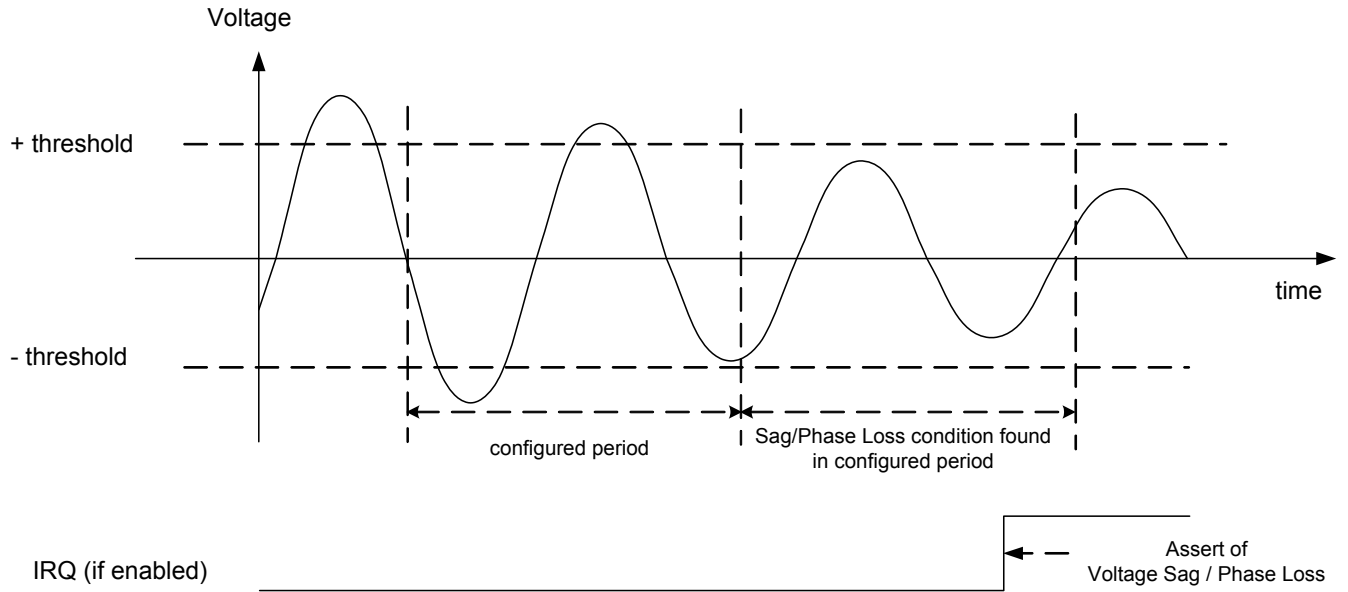

**Figure-25 Zero-Crossing Timing Diagram (per phase)**

**Table-20 Zero-Crossing Specification**

Symbol	Description	Min	Typ	Max	Unit
$T_{ZX}$	High Level Width		5		ms
$T_D$	Delay Time		0.2	0.5	ms

### 6.6 VOLTAGE SAG AND PHASE LOSS TIMING



**Figure-26 Voltage Sag and Phase Loss Timing Diagram**

## 6.7 ABSOLUTE MAXIMUM RATING

Parameter	Maximum Limit
Relative Voltage Between AVDD and AGND	-0.3V~4.5V
Relative Voltage Between DVDD and DGND	-0.3V~4.5V
Analog Input Voltage (I1P, I1N, I2P, I2N, I3P, I3N, V1P, V1N, V2P, V2N, V3P, V3N)	-0.6V~AVDD
Digital Input Voltage	-0.3V~DVDD
	-0.3V~5.5V, for 5V tolerance pins
Operating Temperature Range	-50~120 °C
Maximum Junction Temperature	150 °C

Package Type	Thermal Resistance $\theta_{JA}$	Unit	Condition
TQFP48	58.5	°C/W	No Airflow

# PACKAGE DIMENSIONS

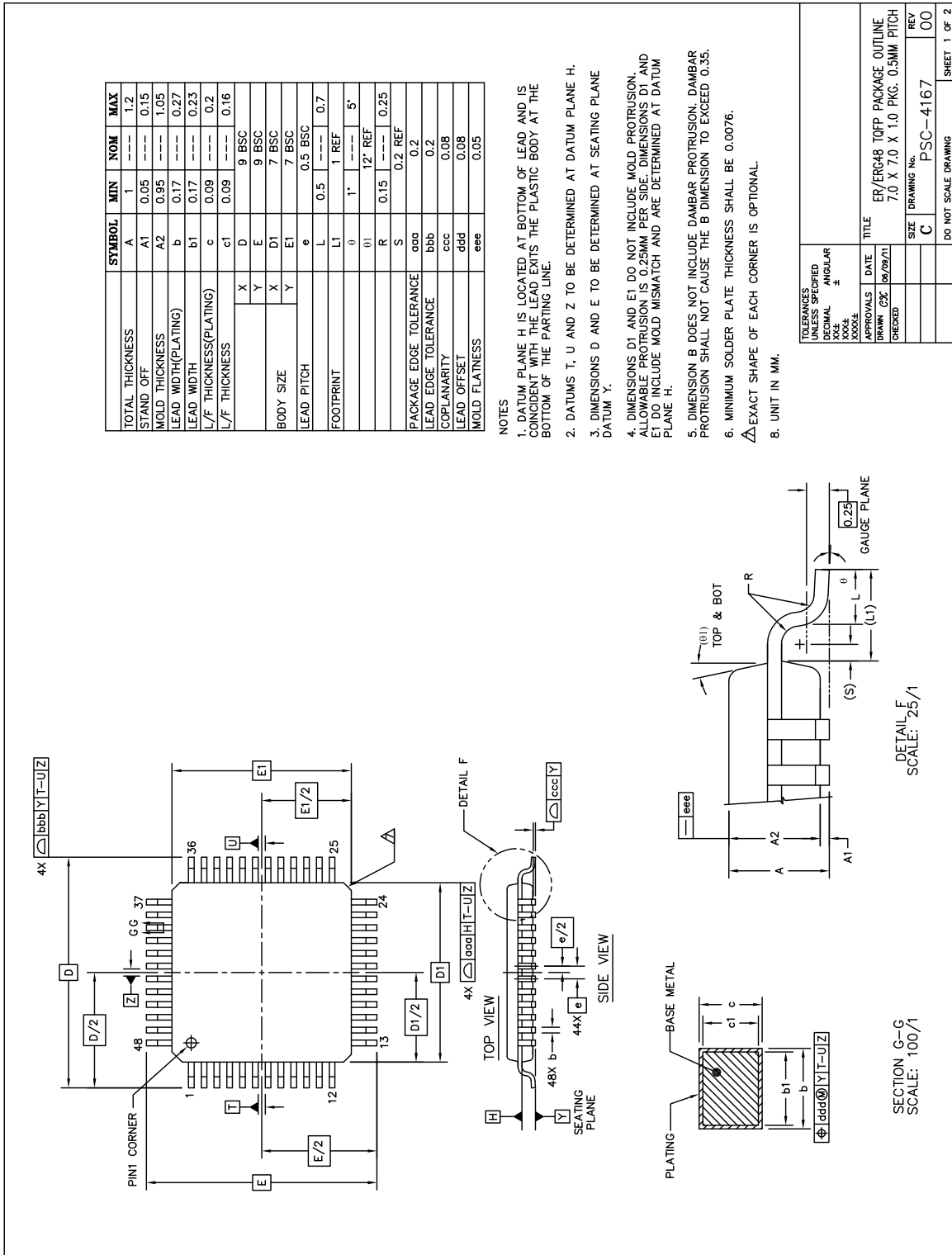



## ORDERING INFORMATION

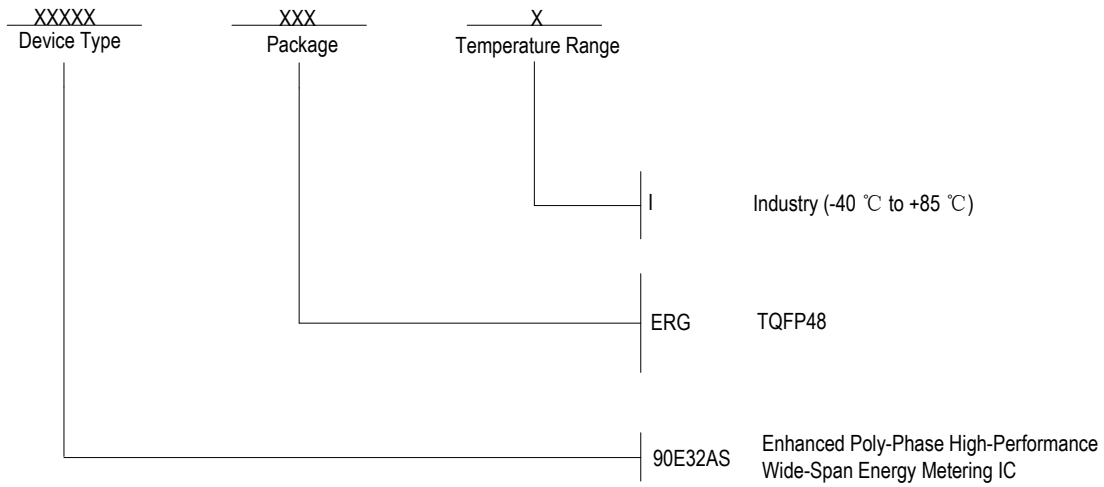

## DATASHEET DOCUMENT HISTORY