

# DC-DC Converter FN1-XXXXXB3N Series



## Typical Features

- ◆ Fixed input voltage, Isolated & unregulated output, Output power 1W
- ◆ High Efficiency up to 86%
- ◆ Small compact SIP packing
- ◆ No external component required
- ◆ Isolation Voltage 3000VDC
- ◆ Operating Temperature: -40°C ~ +105°C
- ◆ Plastic Case, meet UL94 V-0 standard



Test Condition: Unless otherwise specified, data in the datasheet should be tested under the conditions of inputting nominal voltage, pure resistance rated load and Ta=25°C

## Application Field

It could be widely used for instrument, communication, pure digital circuit, general low frequency analog circuit, relay drive circuit, data exchange circuit, etc.

## Typical Product List

Model	Input Voltage Range (VDC)		Output Voltage/Current (Vo/Io)		Input Current(mA) Nominal Voltage		Max. Capacitive Load uF	Ripple & Noise (Max.) mVp-p	Efficiency (%)	
	Nominal	Range	Voltage (VDC)	Current(mA) MAX./Min.	Full load Typ.	No Load Typ.			Min.	Typ.
FN1-3V3S3V3B3N	3.3	2.97 - 3.63	3.3	303	415	25	470	100	69	73
FN1-3V3S05B3N			5	200	415	25	470	100	74	78
FN1-3V3S24B3N			24	42	415	25	470	100	74	78
FN1-05S3V3B3N	5	4.5 - 5.5	3.3	303	274	20	470	100	69	73
FN1-05S05B3N			5	200	274	20	2400	100	76	80
FN1-05S07B3N			7	143	230	10	470	100	78	82
FN1-05S09B3N			9	111	274	20	470	100	76	80
FN1-05S12B3N			12	83	274	20	470	100	76	80
FN1-05S15B3N			15	67	274	20	470	100	77	81
FN1-05S24B3N			24	42	274	20	470	100	77	81
FN1-09S09B3N	9	8.1-9.9	9	111	122	10	470	100	82	86
FN1-12S3V3B3N	12	10.8 - 13.2	3.3	303	114	20	470	100	71	75
FN1-12S05B3N			5	200	114	20	470	100	76	80
FN1-12S09B3N			9	111	114	20	470	100	76	80
FN1-12S12B3N			12	83	114	20	470	100	76	80

## DC-DC Converter FN1-XXXXXB3N Series



FN1-12S15B3N			15	67	114	20	470	100	77	81
FN1-12S24B3N			24	42	114	20	470	100	77	81
FN1-15S05B3N	15	13.5	5	200	84	12	470	100	76	80
FN1-15S09B3N			9	111	84	12	470	100	76	80
FN1-15S12B3N		-	12	83	84	10	470	100	76	80
FN1-15S15B3N		16.5	15	67	84	12	470	100	77	81
FN1-15S24B3N		24	24	42	84	12	470	100	76	80
FN1-24S3V3B3N		24	21.6 - 26.4	3.3	303	58	8	470	100	71
FN1-24S05B3N	5			200	58	6	470	100	75	79
FN1-24S09B3N	9			111	58	8	470	100	76	80
FN1-24S12B3N	12			83	58	8	470	100	77	81
FN1-24S15B3N	15			67	58	10	470	100	77	81
FN1-24S24B3N	24			42	50	7	470	100	81	83
FN1-05D05B3N	5	4.5	±5	±100	274	17	220	100	76	80
FN1-05D09B3N			±9	±56	274	23	220	100	76	80
FN1-05D12B3N		-	±12	±42	274	25	220	100	76	80
FN1-05D15B3N		5.5	±15	±33	274	28	220	100	77	81
FN1-05D24B3N		±24	±21	274	33	220	100	77	81	
FN1-12D05B3N	12	10.8	±5	±100	114	12	220	100	76	80
FN1-12D09B3N			±9	±56	114	14	220	100	77	81
FN1-12D12B3N		-	±12	±42	114	6	220	100	79	83
FN1-12D15B3N		13.2	±15	±33	114	16	220	100	77	81
FN1-12D24B3N		±24	±21	114	16	220	120	76	80	
FN1-15D05B3N	15	13.5	±5	±100	84	12	220	100	76	80
FN1-15D15B3N		-	±15	±33	84	13	220	100	77	81
FN1-15D24B3N		16.5	±24	±21	84	12	220	100	74	78
FN1-24D05B3N	24	21.6 - 26.4	±5	±100	58	8	220	100	76	80
FN1-24D09B3N			±9	±56	58	8	220	100	76	80
FN1-24D12B3N			±12	±42	58	8	220	100	77	81
FN1-24D15B3N			±15	±33	58	8	220	100	75	79

Note:

1. “\*” are models under developing.
2. In order to ensure the converter can work reliably with high efficiency, the minimum load should not less than 10% rated load when it is used. If the needed power is indeed small, please parallel a resistor at the output side, the resistance recommended equal to 10% nominal power.
3. The capacitive loads of positive and negative outputs are identical.

Input Specifications

Item	Test Condition	Min.	Typ.	Max.	Unit
Input Overshoot Voltage (1Second.max.)	3.3Vdc Input	-0.7	-	7	VDC
	5Vdc Input	-0.7	-	9	
	12Vdc Input	-0.7	-	18	
	15Vdc Input	-0.7	-	21	
	24Vdc Input	-0.7	-	30	
Input Filter	Capacitor Filter				

Output Specifications

ITEM	Working Conditions		Min.	Typ.	Max.	Unit
Output Power			0.2	--	1	W
Output Voltage Accuracy	Nominal input, Full load		--	±2	±5	%
Load Regulation	10% ~ 100% nominal load	3.3Vdc output	--	--	20	
		Other output	--	--	15	
Line Voltage Regulation	Input Voltage Change±1%	3.3Vdc output	--	--	±1.5	
		Other output	--	--	±1.2	
Ripple & Noise①	Nominal input,full load, 20MHZ bandwidth	Other output	--	75	100	mVp-p
		24Vdc output	--	90	100	
Temperature Drift Coefficient	100% Full Load		--	--	±0.03	%/°C
Output Short Circuit Protection	Continuous short-circuit protection, self-recovery					

NOTE:①Ripple & Noise tested by twisted-pair method.

General Specifications

Switching Frequency	typical	100KHz (Typ.)
Operating Temperature	Refer to Temperature Derating Curve	-40°C ~ +105°C
Storage Temperature		-55°C ~ +125°C
Shell temperature rise during work	Within Temperature Derating Curve	25°C
Relative Humidity	No condensing	5%~95%
Case Material		Black flame-retardant heat-resistant Plastic(UL94 V-0)

# DC-DC Converter FN1-XXXXXB3N Series



Pin Withstand Welding Temp	Distance to case 1.5mm, 10S	300°C MAX
Isolation Voltage	Test 1 minute, leakage current < 0.5mA	3000Vdc
Isolation Capacitor	Input/output, 100KHz/0.1V	20 pF (Typ.)
MTBF	MIL-HDBK-217F@25°C	35X10 <sup>5</sup> Hrs
Product Weight		2.1g(Typ.)
Package	Tube(225*20.5*12.5mm) Inner	25PCS
	Box(245*155*85mm)	2000PCS(Total 80Tubes)

## EMC Characteristics

Items	Sub-Items	Test Standard	Class
EMS	ESD	1. IEC/EN61000-4-2	Contact ±6KV perf. Criteria B
		2. IEC/EN61000-4-2	Contact ±8KV perf. Criteria B

## Packing Dimension

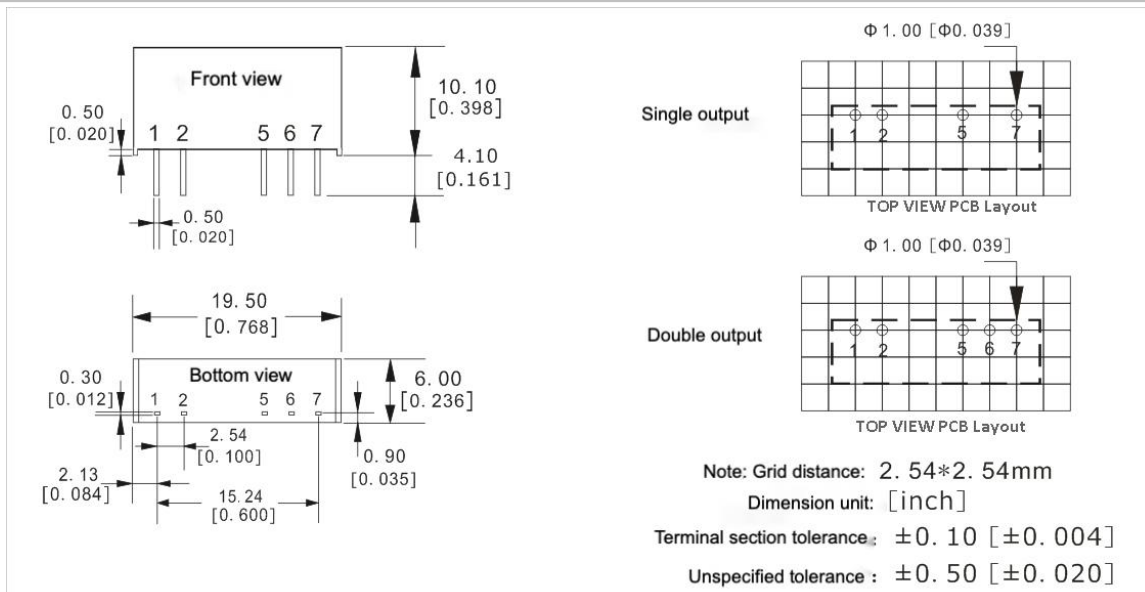

Packing Code	L x W x H	
B	19.50× 6.00 × 10.00mm	0.768 × 0.236 × 0.394inch

## Pin Function

Pin Function	1	2	3	4	5	6	7
Single(S)	+Vin	GND	NP	NP	-Vo	NP	+Vo
Dual(D)	+Vin	GND	NP	NP	-Vo	COM	+Vo

Note: if the definition of pin is not in accordance with the model selection manual, please refer to the label on actual item.

Ripple & Noise Test: (Twisted Pair Method 20MHZ bandwidth)

Test Method:

a. 12# twisted pair to connect, Oscilloscope bandwidth set as 20MHz, 100M bandwidth probe, terminated with 0.1uF polypropylene capacitor and 10uF high frequency low resistance electrolytic capacitor in parallel, oscilloscope set as Sample pattern.

b. Input terminal connect to power supply, output terminal connect to electronic load through jig plate, Use 30cm±2 cm sampling line, Power line selected from corresponding diameter wire with insulation according to the flow of output current.

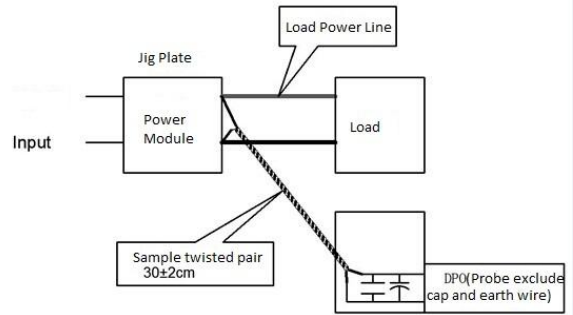

Temperature Curve

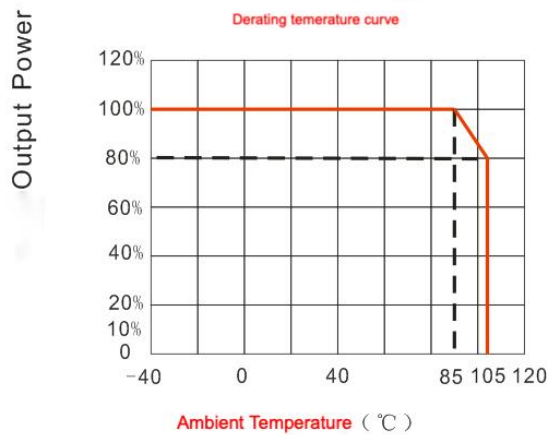

Design and Application Circuit Recommended

1. Output load requirements

a. In order to ensure the converter can work reliably with high efficiency, the minimum load should not less than 10% rated load when it is used. If the needed power is indeed small, please parallel a resistor at the output side, the resistance equal to 10% nominal load.

b. The maximum capacitive load is tested under nominal input full load, and cannot exceed the maximum capacitive load of output terminal under operation, otherwise it will cause it difficult to start up and damage the product.

2. Recommended circuit

In order to ensure the input/output ripple and noise decreased, capacitor filter net could be connected to input and output terminal, application circuit as below photo 1; choosing suitable filter capacitor is very important, start-up problems may be caused by too large capacitance. To ensure the modules running safely and reliably, the recommended capacitive load values as shown in Table 1. (But for the actual output power of application circuit is less than 0.5W, suggest not to connect external capacitor)

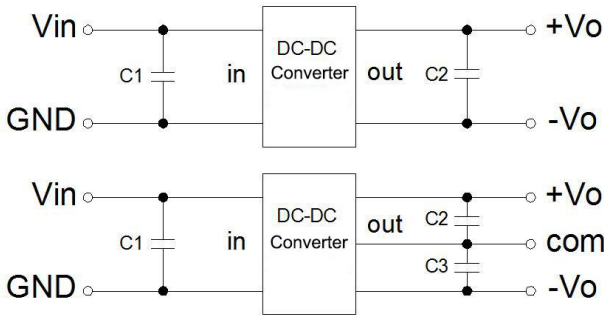

Recommended capacitive load value (Table 1)

Vin (Vdc)	C1 (μF)	Vout (Vdc)	C2 (μF)	Vout (Vdc)	C2, C3 (μF)
3.3/5	4.7	3.3/5	10	±3.3/±5	4.7
12	2.2	9	4.7	±9	2.2
15	1	12	2.2	±12	1
24	1	15	1	±15	0.47
--	--	24	0.47	±24	0.22

### 3. Output regulated voltage and over voltage protection circuit

The simplest device to protect output regulated voltage, over voltage and over current is to cascade a linear regulator with overheat protection at input or output terminal, and connect a capacitor filter net (see below picture), filter capacitive value recommended see table 1, Linear regulator is chosen according to the actual voltage, current needed in working, or choose our NW series products.

#### Single

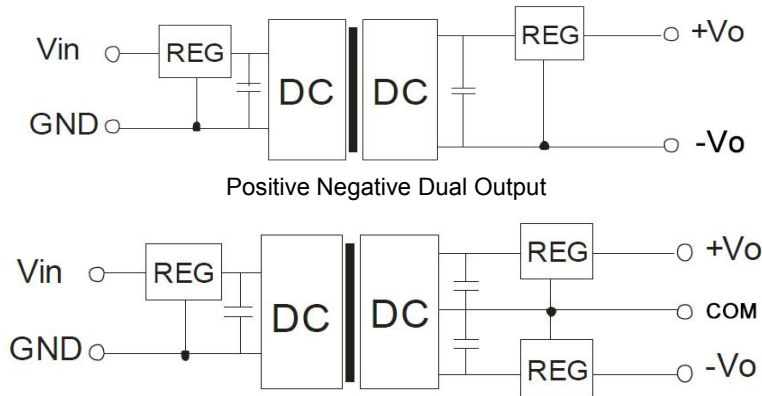

#### Note:

1. This product cannot be used in parallel, and do not support hot-plugging;
2. If the product works below the minimum required load, it cannot guarantee that the product performance meets all performance indicators in this manual;
3. All index testing methods in this datasheet are based on our Company's corporate standards.
4. The product specification may be changed at any time without prior notice.