

DC-DC Converter

NWV75-XXSXXAN Series

Typical Features

- ◆ Fixed input voltage, Isolated & regulated output, Output power 0.75W
- ◆ High Efficiency up to 75%
- ◆ Small compact SIP packing
- ◆ No external component required
- ◆ Isolation Voltage 1500VDC
- ◆ Operating Temperature: -40°C ~ +85°C
- ◆ Plastic Case, meet UL94 V-0 standard



Test Condition: Unless otherwise specified, data in the datasheet should be tested under the conditions of inputting nominal voltage, pure resistance rated load and Ta=25°C

Application Field

It could be widely used for instrument, communication, pure digital circuit, general low frequency analog circuit, relay drive circuit, data exchange circuit, etc.

Typical Product List

Part No.	Input Voltage Range (VDC)		Output Voltage/Current (Vo/Io)		Input Current(mA) Nominal Voltage		Max. Capacitive Load uF	Ripple & Noise (Max.) mVp-p	Efficiency (%)@output full load, nominal input voltage	
	Nominal	Range	Voltage (VDC)	Current(mA) MAX./Min.	Full load Typ.	No Load Typ.			Min.	Typ.
NWV75-05S3V3AN	5	4.75 - 5.25	3.3	200/20	200	6	2400	80	67	70
NWV75-05S05AN			5	150/15	205	6	2400	80	70	73
NWV75-05S12AN			12	62/7	186	8	560	80	72	75
NWV75-12S3V3AN	12	11.4 - 12.6	3.3	200/20	86	8	2400	80	67	70
NWV75-12S05AN			5	150/15	83	8	2400	80	70	73
NWV75-12S12AN			12	62/7	83	8	560	80	72	75
NWV75-24S3V3AN	24	22.8 - 25.2	3.3	200/20	45	8	2400	80	67	70
NWV75-24S05AN			5	150/15	41	8	2400	80	70	73
NWV75-24S12AN			12	62/7	41	8	560	80	72	75

In order to ensure the converter can work reliably with high efficiency, the minimum load should not less than 10% rated load when it is used. If the needed power is indeed small, please parallel a resistor at the output side, the resistance recommended equal to 10% nominal power.

Input Specifications

Item	Test Condition	Min.	Typ.	Max.	Unit
Input Overshoot Voltage (1Second.max.)	5Vdc Input	-0.7	-	9	VDC
	12Vdc Input	-0.7	-	18	

DC-DC Converter NWV75-XXSXXAN Series

	24Vdc Input	-0.7	-	30	
Input Filter	Capacitor Filter				

Output Specifications

ITEM	Working Conditions	Min.	Typ.	Max.	Unit
Output Power		0.07	--	0.75	W
Output Voltage Accuracy	Nominal input, Full load	--	±2	±3	%
Load Regulation	10% ~ 100% nominal load	--	--	±3	
Line Voltage Regulation	Input Voltage Change±1%	--	--	±0.25	
Ripple & Noise①	Nominal input, full load,20MHZ bandwidth	--	35	80	mVp-p
Temperature Drift Coefficient	100% Load	--	--	±0.03	%/°C
Output Short Circuit Protection	Continuous, self-recovery				

NOTE:① Ripple & Noise Tested by twisted-pair method, for details please check Design and Application Circuit.

General Specifications

Switching Frequency	typical	260KHz (Typ.)
Operating Temperature	Refer to Temperature Derating Curve	-40°C ~ +85°C
Storage Temperature		-55°C ~ +125°C
Shell temperature rise during work	Within Temperature Derating Curve	25°C(Typ.)
Relative Humidity	No condensing	5%~95%
Case Material		Black flame-retardant heat-resistant Plastic(UL94 V-0)
Pin withstand welding temp	Distance to case 1.5mm, 10s	300°C MAX
Isolation Voltage	Test 1 minute, leakage current<0.5mA	1500Vdc
Isolation Capacitor	Input/Output, 100KHz/0.1V	20 pF (Typ.)
MTBF	MIL-HDBK-217F@25°C	35X10 ⁵ Hrs
Product Weight		1.4g(Typ.)
Package	Tube(525*18*10mm)	43PCS
	Inner Box(542*110*155mm)	3440PCS(Total 80Tubes)

Packing Dimension

DC-DC Converter

NWX75-XXSXXAN Series

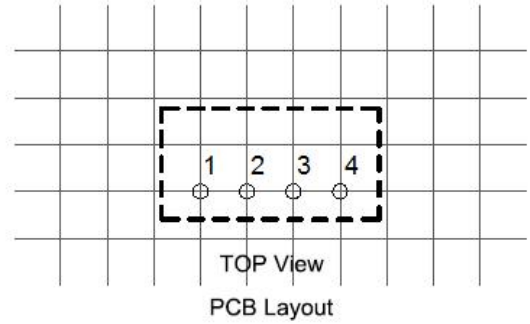
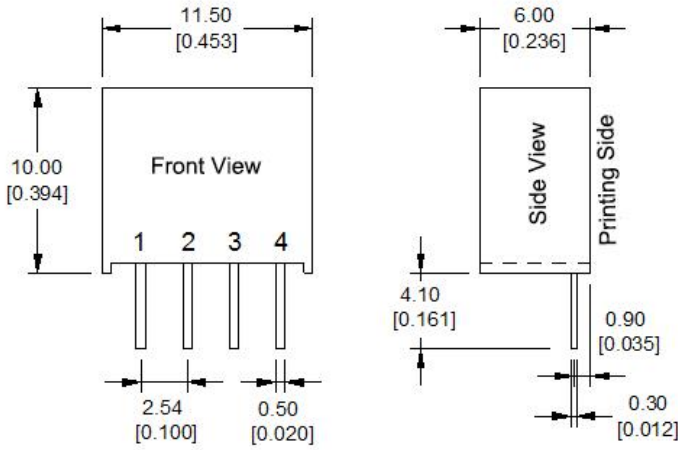

Note: Grid 2.54x2.54mm
 unit:mm[inch]
 pin tolerance:±0.10[±0.004]
 general tolerance:±0.50[±0.020]

Packing Dimension

Recommend PCB Circuit

Packing Code	L x W x H	
A	11.50× 6.00 × 10.00mm	0.453 × 0.236 × 0.394inch

Pin Function

Single(S)	1	2	3	4
	GND	+Vin	-Vo	+Vo

Note: if the definition of pin is not in accordance with the model selection manual, please refer to the label on actual item.

Ripple & Noise Test: (Twisted Pair Method 20MHZ bandwidth)

Test Method:

a. 12# twisted pair to connect, Oscilloscope bandwidth set as 20MHZ, 100M bandwidth probe, terminated with 0.1uF polypropylene capacitor and 10uF high frequency low resistance electrolytic capacitor in parallel, oscilloscope set as Sample pattern.

b. Input terminal connect to power supply, output terminal connect to electronic load through jig plate, Use 30cm±2 cm sampling line, Power line selected from corresponding diameter wire with insulation according to the flow of output current.

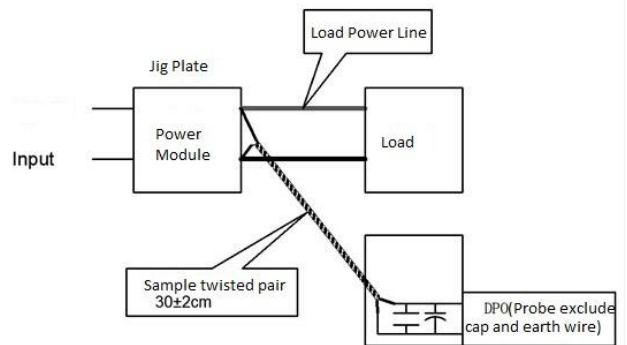

Product Characteristic Curve

DC-DC Converter NWV75-XXSXXAN Series

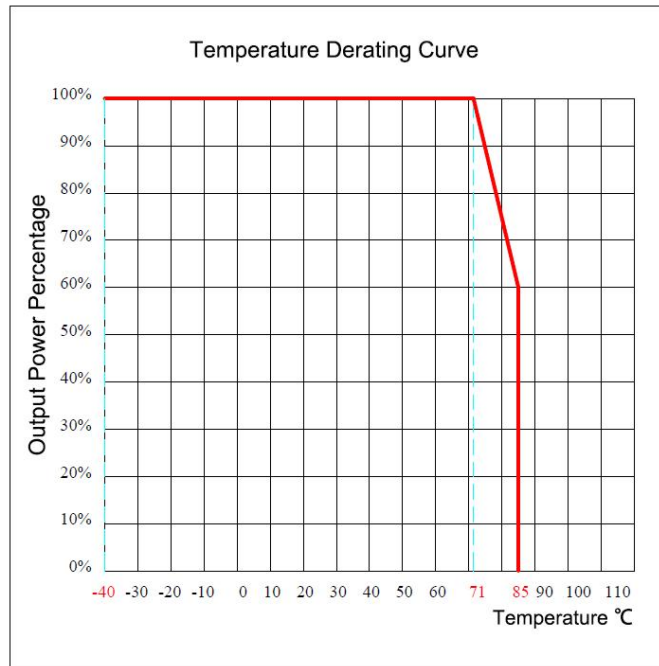

Design and Application Circuit Recommended

1. Output load requirements

- a. In order to ensure the converter can work reliably with high efficiency, the minimum load should not less than 10% rated load when it is used. If the needed power is indeed small, please parallel a resistor at the output side, the resistance equal to 10% nominal load.
- b. The maximum capacitive load is tested under nominal input full load, and cannot exceed the maximum capacitive load of output terminal under operation, otherwise it will cause it difficult to start up and damage the product.

2. Recommended circuit

a. In order to ensure the input/output ripple and noise decreased, capacitor filter net could be connected to input and output terminal, application circuit as below photo 1; choosing suitable filter capacitor is very important, start-up problems may be caused by too large capacitance. To ensure the modules running safely and reliably, the recommended capacitive load values as shown in Table 1.

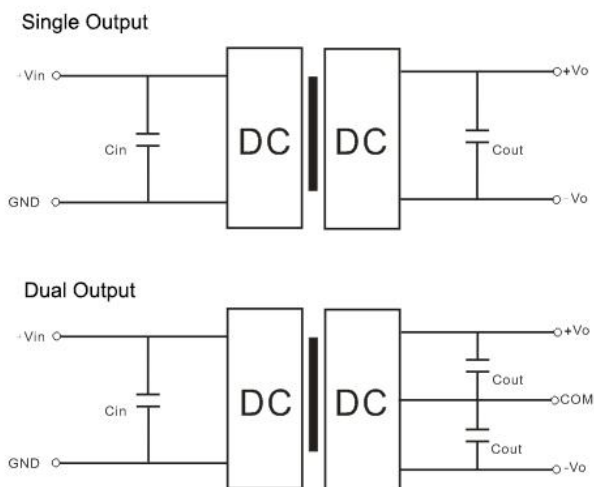

Recommended capacitive load value(Table 1)

Vin (Vdc)	Cin	Single Vout Vdc	Cout (μF)	Dual Vout (Vdc)	Cout (μF)
5	10 μF/16V	3.3	10 μF/16V	±3.3	4.7 μF/16V
12	2.2 μF/25V	5	10 μF/16V	±5	4.7 μF/16V
15	2.2 μF/25V	9	2.2 μF/25V	±9	2.2 μF/25V
24	1 μF/50V	12	2.2 μF/25V	±12	1 μF/25V
--	--	15	1 μF/25V	±15	1 μF/16V
--	--	24	1 μF/50V	±24	0.47 μF/50V

DC-DC Converter

NWX75-XXSXXAN Series

3. EMC typical recommended circuit

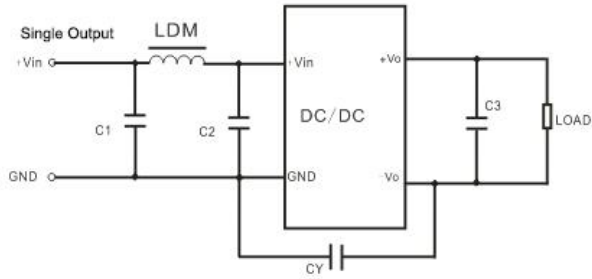

Input Voltage		5VDC	12/15/24VDC
EMI	C1/C2	4.7 μ F/16V	4.7 μ F/50V
	CY	270pF/2kV	270pF/2kV
	C3	Refer to Cout Spes	according to Table 1
	LDM	6.8 μ H	6.8 μ H

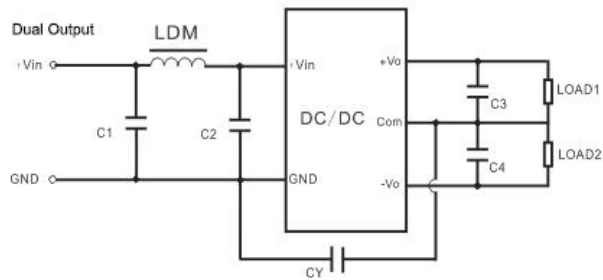

Input Voltage		5VDC	12/15/24VDC
EMI	C1/C2	4.7 μ F/16V	4.7 μ F/50V
	CY	270pF/3kVdc	270pF/3kVdc
	C3/C4	Refer to Cout Spes	according to Table 1
	LDM	6.8 μ H	6.8 μ H

Note:

1. This product cannot be used in parallel, and do not support hot-plugging;
2. If the product works below the minimum required load, it cannot guarantee that the product performance meets all performance indicators in this manual;
3. All index testing methods in this datasheet are based on our Company's corporate standards
4. The product specification may be changed at any time without prior notice.