

DC/DC Converter

PFD12-XXSXXA3(C)2(-T)(-TS) Series



Typical Feature

- ◆ Wide input voltage range (4:1),Output Power 12W
- ◆ Transfer Efficiency up to 89%
- ◆ Stand-by Power Consumption as low as 0.15W
- ◆ Output super-fast start up
- ◆ Continuous Short Circuit protection, Self-recovery
- ◆ Input under voltage, output over voltage, short circuit, over current protection
- ◆ Switching Frequency 330KHz
- ◆ Isolation Voltage 1500VDC
- ◆ Operating Temperature: -40°C~+85°C
- ◆ Good EMI performance
- ◆ International standard pin-out



Application Field

PFD12-XXSXXA3(C)2(-T)(-TS) is a newly designed DIP 1X1 packed, 12W output power, ultra wide input range 4:1, low stand-by power consumption, isolated regulated output DC-DC converter, could be widely used for industrial control, instrument, communication, power electricity, internet of things field. For harsh EMC environment, the application circuit in the datasheet is strongly recommended.

Typical Product List

Certificate	Part No	Input Voltage Range (VDC)		Output Voltage/Current (Vo/Io)		Input Current (mA) Nominal Voltage		Max. Capacitive Load uF	Ripple & Noise		Efficiency (%)@output full load, input nominal voltage	
		Nominal	Range	Voltage (VDC)	Current(mA) MAX./Min.	Full load typ.	No Load typ.		mVp-p		Min	Typ
									Typ.	Max.		
-	PFD12-18S3V3A3(C)2	24	9-36	3.3	2400/0	407	2	5000	50	100	79	81
-	PFD12-18S05A3(C)2	24	9-36	5	2000/0	502	2	3000	50	100	81	83
-	PFD12-18S06A3(C)2	24	9-36	6	2000/0	588	2	3000	50	100	83	85
-	PFD12-18S09A3(C)2	24	9-36	9	1333/0	581	2	1500	50	100	84	86
-	PFD12-18S12A3(C)2	24	9-36	12	1000/0	575	2	1000	50	100	85	87
-	PFD12-18S15A3(C)2	24	9-36	15	800/0	568	2	1000	50	100	86	88
	PFD12-18S17A3(C)2	24	9-36	17	706/0	568	2	1000	50	100	86	88
	PFD12-18S20A3(C)2	24	9-36	20	600/0	581	2	680	50	100	84	86
-	PFD12-18S24A3(C)2	24	9-36	24	500/0	568	2	470	50	100	86	88

DC/DC Converter

PFD12-XXSXXA3(C)2(-T)(-TS) Series



-	PFD12-36S3V3A3(C)2	48	18-75	3.3	2400/0	211	2	5000	50	100	76	78
-	PFD12-36S05A3(C)2	48	18-75	5	2000/0	251	2	3000	50	100	81	83
	PFD12-36S5V5A3(C)2	48	18-75	5.5	2181/0	297	2	3000	50	100	82	84
-	PFD12-36S09A3(C)2	48	18-75	9	1333/0	291	2	1500	50	100	84	86
-	PFD12-36S12A3(C)2	48	18-75	12	1000/0	287	2	1000	50	100	85	87
-	PFD12-36S15A3(C)2	48	18-75	15	800/0	281	2	1000	50	100	87	89
-	PFD12-36S24A3(C)2	48	18-75	24	500/0	284	2	470	50	100	86	88

- Suffix "C" is with control function; "N" is without control function. "-T" for chassis mounting, "-TS" for DIN-Rail mounting, DIN-Rail width is: 35mm;
-
- Max capacitive load is, when the power supply is fully loaded, the max capacity could be connected to output, if exceed, the power supply cannot start-up;

Input Specification

Stand-by Consumption	Typ: 0.15 W		
Input Filter	π filter		
Input Under-Voltage Protection	Typ: 6.5VDC(24V nominal input); Typ:13VDC(48V nominal input)		
CTRL*	Module turn-on	CTRL suspended or TTL high level (3.3-12VDC)	
	Module turn-off	CTRL connect to -Vin or low level (0-1.2VDC)	
	Input current when switched off	2mA (TYP)	

Note: *The voltage of CTRL pin is relative to -Vin pin.

Output Specification

Output Voltage Accuracy	Full voltage full load	Vo	±2.0% Max
Line Regulation	Nominal load, full voltage range	Vo	±0.5% Max
Load Regulation	5% ~ 100% nominal load	Vo	±1.0% Max
Ripple & Noise	Twisted Pair Method, 20M Hz bandwidth; 5%~100% load		50mVp-p Typ, 100mVp-p Max
Output Over-voltage Protection	110%~160%Vo		
Output Over-load Protection	110%~250%Io		
Output Short circuit Protection	Continuous, Self-recovery		
Dynamic Response	25% nominal load step change $\Delta Vo/\Delta t$		±3% typ, ±5% max /500us
Turn-on delay time	Typical	10ms	
Output Turn-on Overshoot Voltage			≤10%Vo

Note: 0% - 5% of load ripple & noise is less than or equal to 5% Vo.

DC/DC Converter

PFD12-XXSXXA3(C)2(-T)-(-TS) Series



General Specification

Switching Frequency	Typical	330KHz
Operating Temperature	Refer to Temperature Derating Curve	-40°C ~ +85°C
Storage Temperature	-	-55°C ~ +125°C
Max Case Temperature	Within Operating Curve	+105°C
Relative Humidity	No condensing	5%~95%
Case Material	-	Aluminum Metal Case
Cooling Method	-	Free air convection
Isolation Voltage	Input to Output(1500Vdc)	≤ 0.5mA / 1min
Insulation Resistance	Input to Output(500VDC)	≥ 1000MΩ
MTBF	MIL-HDBK-217F@25°C	2X10 ⁵ Hrs
Product Weight	Average	15g

EMC Characteristics

	Total Items	Sub Items	Test Standard	Class
E M C	EMI	CE	CISPR22/EN55032	CLASS B (see recommended circuit photo ②)
		RE	CISPR22/EN55032	CLASS B (see recommended circuit photo ②)
	EMS	RS	IEC/EN61000-4-3	10V/m Perf.Criteria B (see recommended circuit photo 2)
		CS	IEC/EN61000-4-6	3Vr.m.s Perf.Criteria B (see recommended circuit photo 2)
		ESD	IEC/EN61000-4-2	Contact ±4KV Perf.Criteria B
		Surge	IEC/EN61000-4-5	±2KV Perf.Criteria B (see recommended circuit photo 1)
		EFT	IEC/EN61000-4-4	±2KV Perf.Criteria B (see recommended circuit photo 1)
		Voltage dips, short interruptions and voltage variations immunity	IEC/EN61000-4-11	0%~70% Perf.Criteria B

A3 Packing Dimension

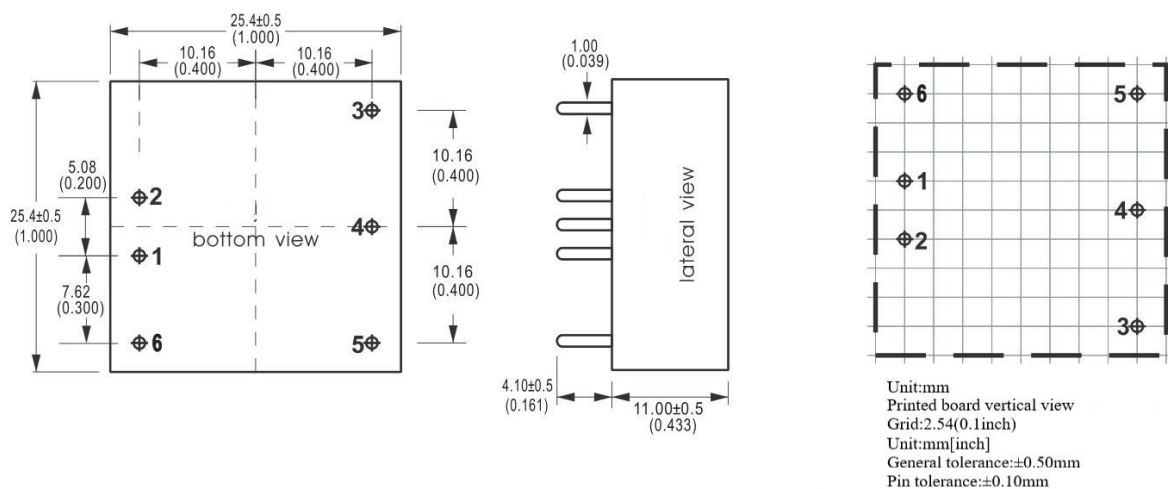

DC/DC Converter

PFD12-XXSXXA3(C)2(-T)(-TS) Series



Pin-out

Pin-Out	1	2	3	4	5	6
PFD12-XXSXXA3C2	-Vin	+Vin	+Vout	NP	GND	CTRL
PFD12-XXSXXA3N2	-Vin	+Vin	+Vout	NP	GND	NP

A3-T Packing Dimension

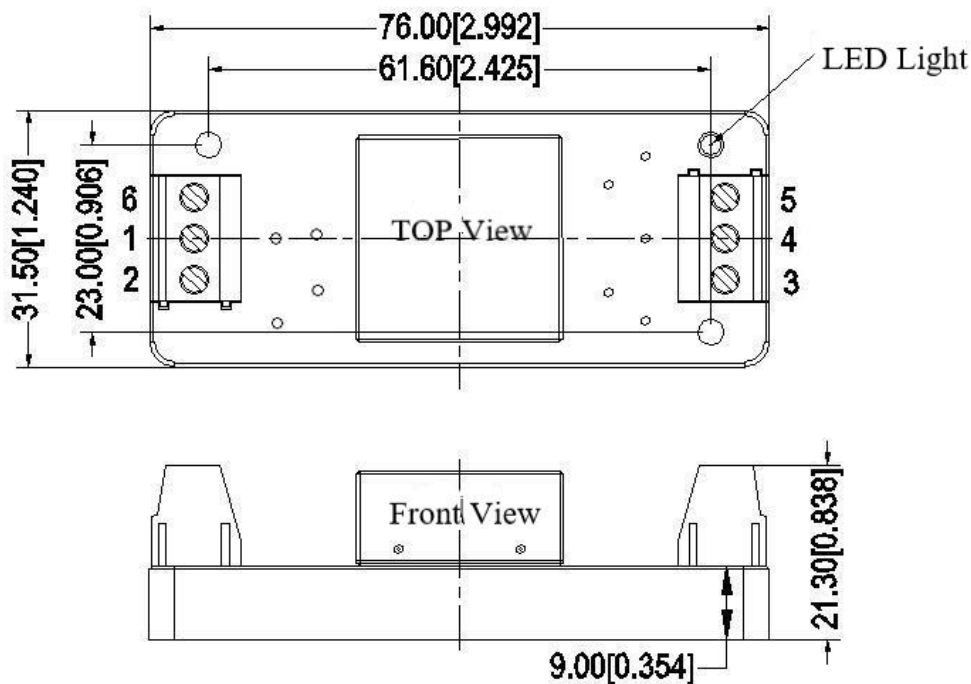

A3-TS Packing Dimension

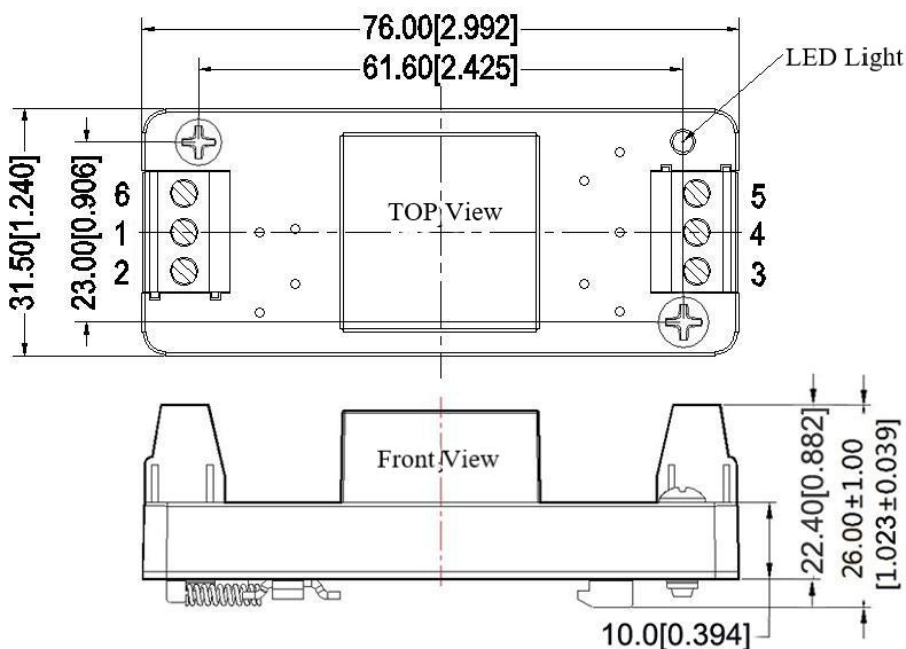

Packing Code

L x W x H

DC/DC Converter

PFD12-XXSXXA3(C)2(-T)(-TS) Series



A3	25.4X 25.4X11 mm	1X1 X0.433inch
A3-T	76X31.5X21.3mm	2.99X1.24X0.838inch
A3-TS	76X31.5X26mm	2.99X1.24X1.023inch

Ripple & Noise Test: (Twisted Pair Method 20MHZ bandwidth)

Test Method:

- a. 12# twisted pair to connect, Oscilloscope bandwidth set as 20MHz, 100M bandwidth probe, terminated with 0.1uF polypropylene capacitor and 10uF high frequency low resistance electrolytic capacitor in parallel, oscilloscope set as Sample pattern.
- b. Input terminal connect to power supply, output terminal connect to electronic load through jig plate, Use 30cm±2 cm sampling line, Power line selected from corresponding diameter wire with insulation according to the flow of output current.

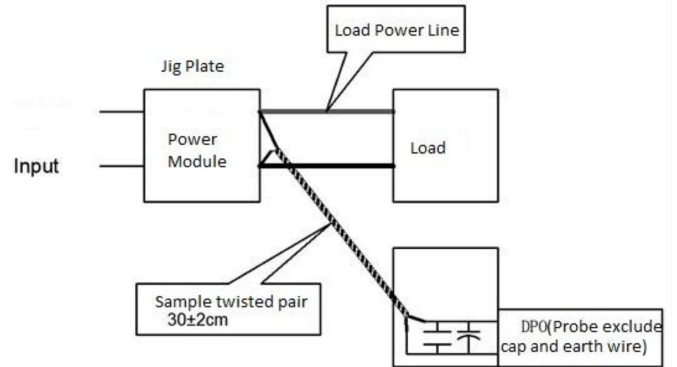

Application Reference:

1. The recommended minimum load is 5% or above 100uF high frequency low resistance electrolytic capacitor.
2. The maximum capacitive load is tested under pure resistance and full load condition;

Product Characteristic Curve

Temperature Derating Curve

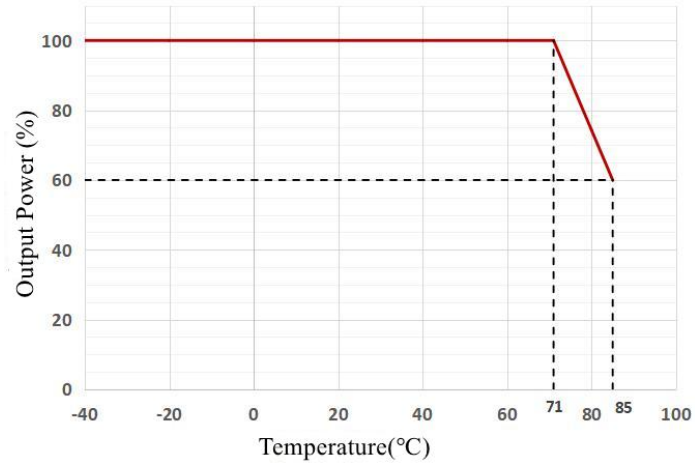

Recommended circuit

1. DC/DC test circuit:

Normal recommended capacitors: C0:47-100uF; C1:100uF.

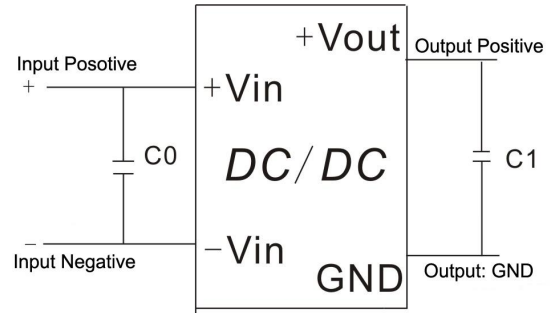

2. Input reflecting ripple current test circuit:

Capacitor C choose low ESR ones, withstand voltage value should be bigger than max input voltage;

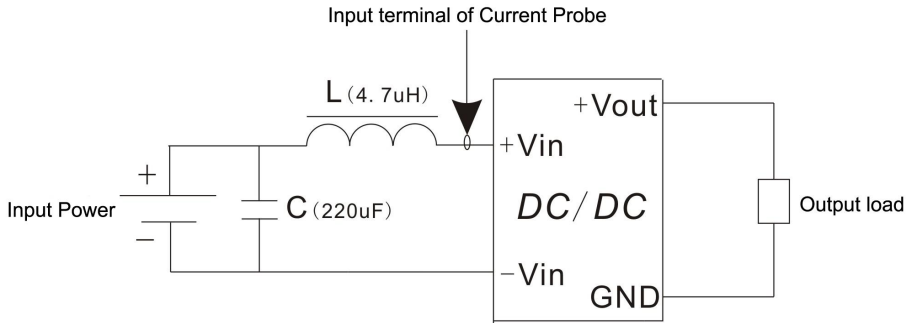

3. EMC external recommended circuit:(Photo 1 and Photo 2)

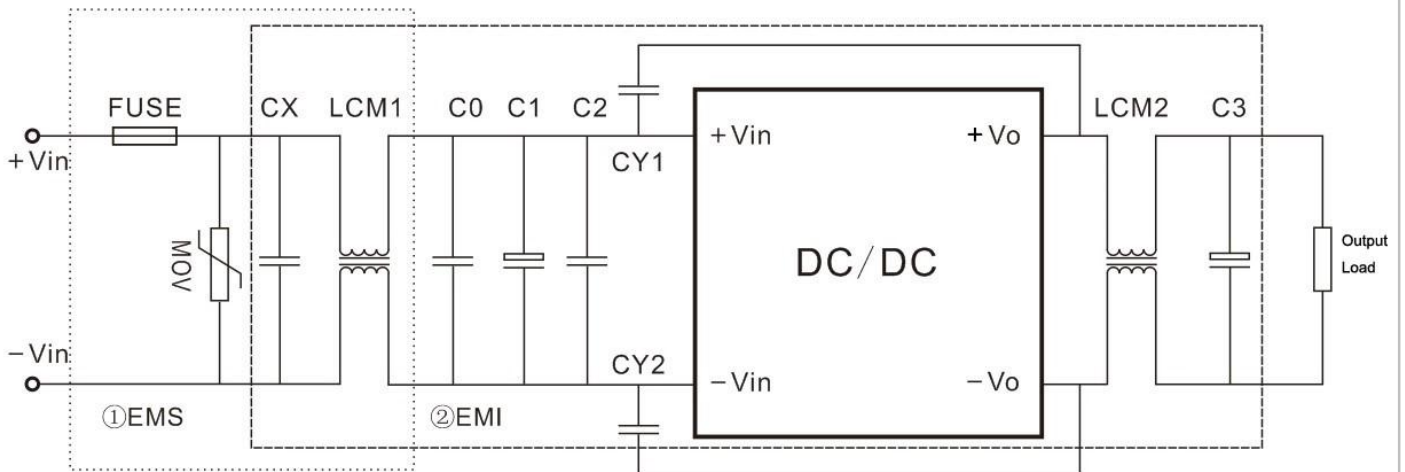

Recommended Spec:

DC/DC Converter

PFD12-XXSXXA3(C)2(-T)(-TS) Series



Component	PFD12-18SXXA3C2 Input	PFD12-36SXXA3C2 Input
FUSE	According to customer's request	
MOV	14D470K	14D101K
CX	0.47uF	0.47uF
LCM1	5mH	5mH
C0	0.1uF/250V	0.1uF/250V
C1	470uF/100V	470uF/100V
C2	0.1uF/250V	0.1uF/250V
LCM2	30uH	30uH
C3	47uF/50V	47uF/50V
CY1,CY2	2.2nF/2000V	

Note:

1. The product should be used under the specification range, otherwise it will cause permanent damage to it.
2. If the product worked beyond the load range or below the minimum load, we cannot ensure that the performance of product is in accordance with all the indexes in this manual;
3. Unless otherwise specified, data in this datasheet should be tested under conditions of Ta=25℃, humidity<75% when inputting nominal voltage and outputting rated load(pure resistance load);
4. All index testing methods in this datasheet are based on our Company's corporate standards;
5. The performance indexes of the product models listed in this manual are as above, but some indexes of non-standard model products will exceed the above-mentioned requirements, and please directly contact our technician for specific information;
6. We can provide customized product service;
7. The product specification may be changed at any time without prior notice.