

# D V0470.001/0.25A

(PRODUCT)	INDUCTANCE		6*8-470UH±15%
-----------	------------	--	---------------

1、DIMENSION(外形尺寸图 单位: mm) : 2、SCHEMATIC

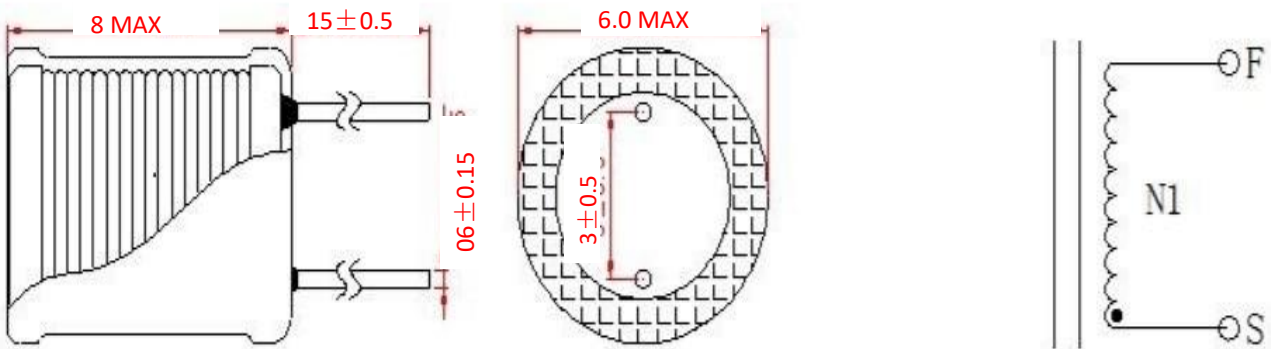

### 3、WINDING TABLE

NO.	S-F	Wire SPEC. & Shares	Turns (TS)	Winding Way	是否应力释放	TUBE
N1	1-2	2UEW Φ0.180MM*1C	135TS REF	Closely(密绕)	否	φ 7

### 4、ELECTRICAL SPECIFICATION

Test Environment Humidity测试环境湿度:65%±20% RH; Temperature温度:25±2℃

序号	Item	SPEC	Test equipment
1	INDUCTANCE	L(N1)=470UH±15% @ 1KHz 0.3V	VR115 (仪器内阻20Ω)
		L(0.2A) ≥ L(0A)*90% @ 1KHz 0.3V 25℃	VR7220+VR115 (仪器内阻20Ω)
		L(0.25A) ≥ L(0A)*70% @ 1KHz 0.3V 100℃ (抽测)	
2	Q	Q(N1)=0.5 MIN @ 1KHz 0.25V	VR115 (仪器内阻20Ω)
3	DC RESISTANCE(电阻)	R(N1)=3.2Ω MAX	RK2511N
4	HI-POT(抗电强度)	COIL~CORE: AC 500V 5mA 5s	VG2670
5	I/R(绝缘电阻)	COIL~CORE: DC 500V R ≥ 100MΩ	LK2679D
6	Rated Current (额定电流)	0.25A	
7	IsatA (磁饱和电流)	0.25A (使电感量比初始值下降约 30%)	

## 5、Material List

NO.	MATERIAL	SPECIFICATION	UL	MANU FACTURER
1	Core	DR 2W 6*8	N/A	Zhongshan Tongwang Electronic Appliance Co Ltd
				or Equate
2	Wire	xUEW/155, QA-x/155	E221719	ZHEJIANG HONGBO TECHNOLOGY CO LTD
		QA/155	E484764	HUZHOU JUCHENG ELECTRONICS CO LTD
3	TUBE	φ 7	E352639	SHENZHEN WOER HEAT SHRINKABLE MATERIAL CO LTD
				or Equate

## 6、ELECTRICAL TEST

Test Environment Humidity测试环境湿度:65%±20% RH; Temperature温度:20±2℃

Item	Sample No.	1	2	3	4	5
	SPEC					
L	L(N1)=470UH±15% @ 1KHz 0.3V					
Q	Q(N1)=0.5 MIN @ 1KHz 0.25V					
DCR	R(N1)=3.2 Ω MAX					
HI-POT	COIL~CORE: AC 500V 5mA 5s					