

D VK001.00k/0.75A

(PRODUCT)	INDUCTANCE	(DRAWING NO.)	DR 9*12-1MH±10%
-----------	------------	---------------	-----------------

1、DIMENSION (外形尺寸图 单位: mm) :

2、SCHEMATIC

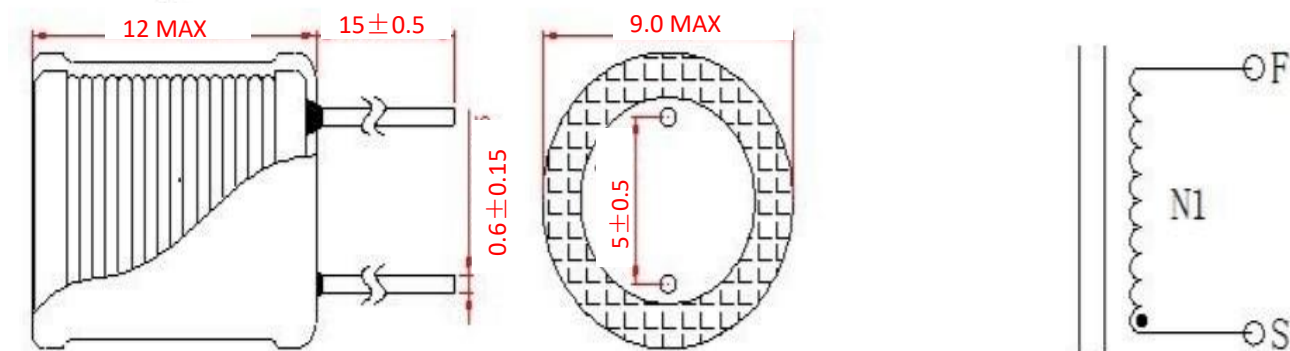

3、WINDING TABLE

NO.	S-F	Wire SPEC. & Shares	Turns (TS)	Winding Way		
N1	1-2	2UEW Φ0.250MM*1C	160TS REF	Closely		φ 10

4、ELECTRICAL SPECIFICATION

Test Environment Humidity 测试环境湿度: 65%±20% RH; Temperature 温度: 25±2°C

序号	Item	SPEC	Test equipment
1	INDUCTANCE (电感)	L(N1)=1MH±10% @ 1KHz 0.3V	VR115 (仪器内阻20Ω)
		L(0.2A) ≥ L(0A)*90% @ 1KHz 0.3V 25°C	VR7220+VR115 (仪器内阻20Ω)
		L(0.3A) ≥ L(0A)*70% @ 1KHz 0.3V 100°C (抽测)	
2	Q	Q(N1)=0.5 MIN @ 1KHz 0.25V	VR115 (仪器内阻20Ω)
3	DC RESISTANCE (电阻)	R(N1)=3.2Ω MAX	RK2511N
4	HI-POT (抗电强度)	COIL~CORE: AC 500V 5mA 5s	VG2670
5	I/R (绝缘电阻)	COIL~CORE: DC 500V R ≥ 100MΩ	LK2679D
6	Rated Current (额定电流)	0.75A	
7	IsatA (磁饱和电流)	0.75A (使电感量比初始值下降约 30%)	

(PRODUCT)	INDUCTANCE	(DRAWING NO.)	9*12-1MH±10%		
-----------	------------	---------------	--------------	--	--

5、Material List

NO.	MATERIAL	SPECIFICATION	UL	MANU FACTURER
1	Core	DR 2W 9*12	N/A	Zhongshan Tongwang Electronic Appliance Co Ltd
				or Equate
2	Wire	xUEW/155, QA-x/155	E221719	ZHEJIANG HONGBO TECHNOLOGY CO LTD
		QA/155	E484764	HUZHOU JUCHENG ELECTRONICS CO LTD
3	TUBE	φ 10	E352639	SHENZHEN WOER HEAT SHRINKABLE MATERIAL CO LTD
				or Equate

6、ELECTRICAL TEST(电气性能测试)

Test Environment Humidity测试环境湿度:65%±20% RH; Temperature温度:20±2℃

Item 项目	SPEC	Sample No.	1	2	3	4	5
L							
Q	Q(N1)=0.5 MIN @ 1KHz 0.25V						
DCR	R(N1)=3.2 Ω MAX						
HI- POT	COIL~CORE: AC 500V 5mA 5s						