

# DM11H

---

**Version** : PRE.002  
**Issue Date** : 2009/10/13  
**File Name** : SP-DM11H-PRE.002.doc  
**Total Pages** : 23

## ***8-Channel Constant Current LED Driver with Error Detection***



新竹市科學園區展業一路9號7樓之1  
SILICON TOUCH TECHNOLOGY INC.  
9-7F-1, Prosperity Road I, Science Based Industrial Park,  
Hsin-Chu, Taiwan 300, R.O.C.  
Tel : 886-3-5645656 Fax : 886-3-5645626

---

---

## DM11H

### 8-Channel Constant Current LED Driver With Error Detection

#### General Description

DM11H is a 8-channel constant-current sink driver specifically designed for LED display applications. The device incorporates shift registers, data latches, and constant current circuitry on the silicon CMOS chip. The maximum output current of each channel is set by a single external resistor. Overall output currents can be adjusted by a 7-bit serial shift-in data. Its built-in LED open/short detection, output channels short to GND detection help users to detect LED failures, outputs short. The thermal alarm and shutdown functions provide the over-temperature protection.

#### Features

- 8-Channel Constant-current outputs: 5mA to 90mA adjustable by one external resistor
- Maximum output voltage: 17V
- Maximum cascade clock frequency: 25MHz
- 7-bit linear global brightness control
- Built-in LED open/short detection: Real-time detection or Smart detection
- Built-in Outputs short to GND detection: Real-time or Smart detection
- Fast detecting response: 100ns (min.)
- Over temperature protection: Alarm (junction temperature > 130°C)  
Shutdown (junction temperature > 170°C)
- Sleep mode (sleep current : <5uA)
- In-rush current control
- Schmitt trigger input
- Power supply voltage: 3.0V to 5.5V
- Package pin assignment compatible to conventional LED drivers (DM114B/115B,DM11C)

#### Applications

- LED Variable Message Signs (VMS) System
- Indoor/Outdoor LED Video Display

#### Packages

SOP16, SSOP16

Block Diagram

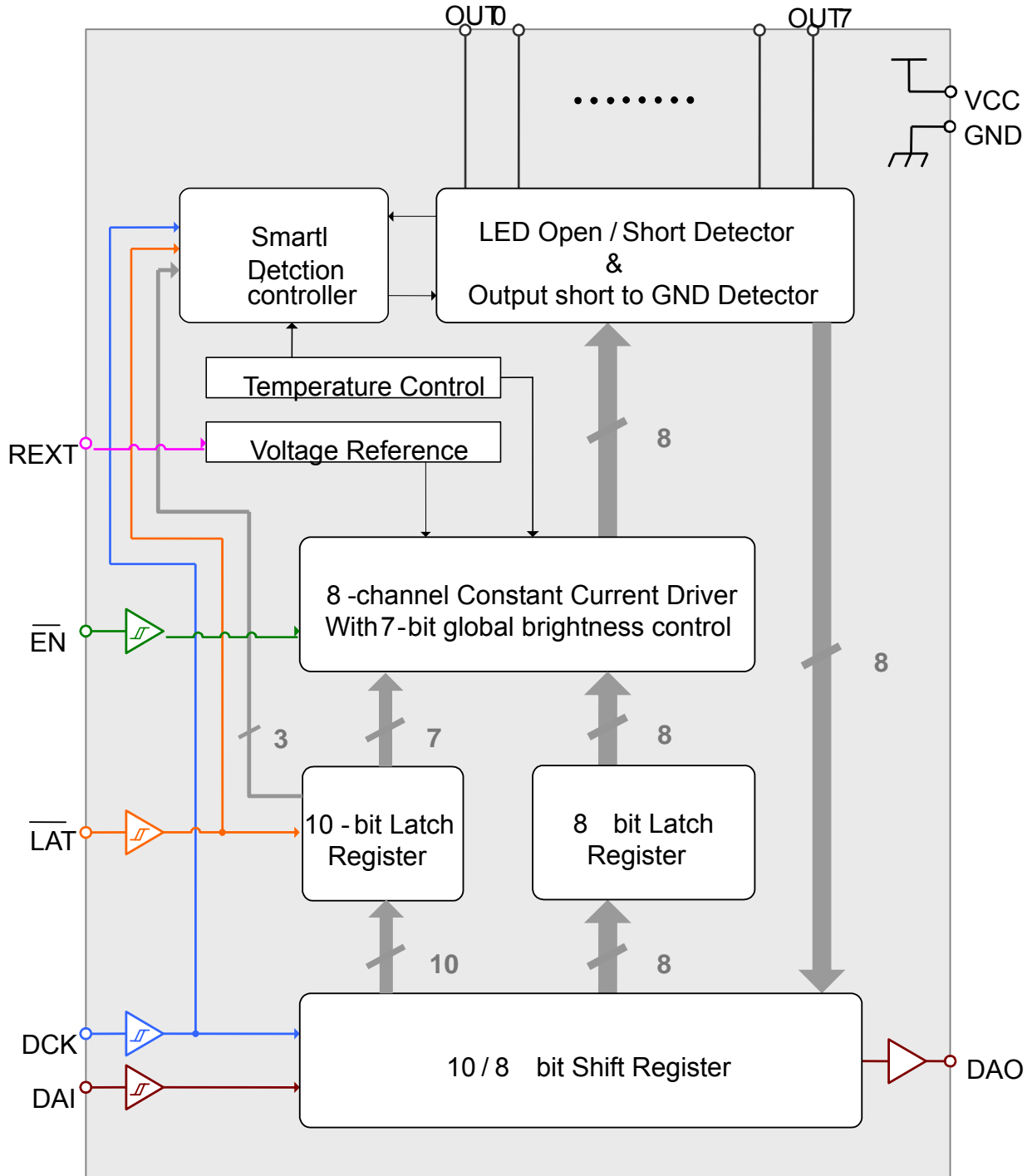

## Pin Connection

SOP16/SSOP16

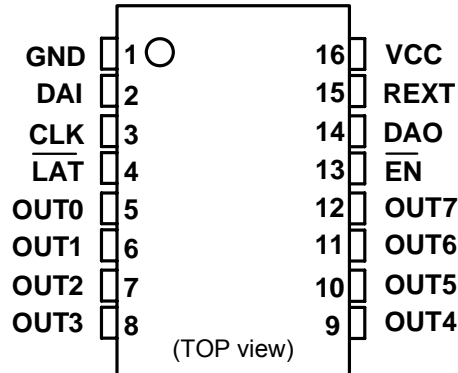

## Pin Description

PIN No.	PIN NAME	FUNCTION
1	GND	Ground terminal.
2	DAI	Serial data input terminal.
3	CLK	Synchronous clock input terminal for serial data transfer. Data is sampled at the rising edge of CLK.
4	$\overline{\text{LAT}}$	Input terminal of data strobe. Data on shift register goes through at the rising edge (edge trigger). Otherwise, data is latched.
5~12	OUT0~7	Sink constant-current outputs (open-drain).
13	$\overline{\text{EN}}$	Output enable terminal: 'H' for all outputs are turned off , 'L' for all outputs are active.
14	DAO	Serial data output terminal.
15	REXT	External resistors connected between REXT and GND for output current value setting.
16	VCC	Supply voltage terminal.

## Equivalent Circuit of Inputs and Outputs

1. CLK, DAI,  $\overline{\text{LAT}}$ ,  $\overline{\text{EN}}$  terminals ( Schmitt Trigger Input )

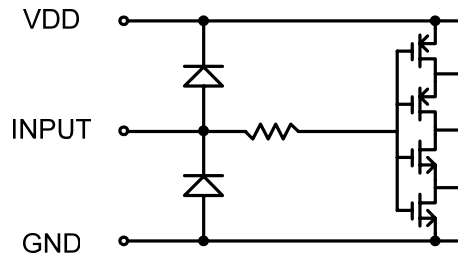

2. DAO terminals

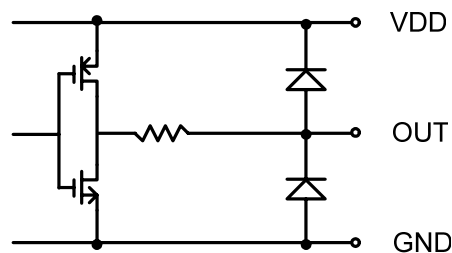

## Maximum Ratings (Ta=25°C, Tj(max) = 120°C)

CHARACTERISTIC	SYMBOL	RATING	UNIT
Supply Voltage	VCC	-0.3 ~ 7.0	V
Input Voltage	VIN	-0.3 ~ VCC+0.3	V
Output Current	IOOUT	90	mA
Output Voltage	VOOUT	-0.3 ~ 17	V
Input Clock Frequency	FCKI	30	MHz
GND Terminal Current	IGND	1500	mA
Power Dissipation	PD	1.17 (SOP16)	W
		0.82 (SSOP16)	
Thermal Resistance	Rth(j-a)	81.2 (SOP16)	°C/W
		115.9 (SSOP16)	
Operating Temperature	Top	-40 ~ 85	°C
Storage Temperature	Tstg	-55 ~ 150	°C

## Recommended Operating Condition

CHARACTERISTIC	SYMBOL	CONDITION	MIN.	TYP.	MAX.	UNIT	
Supply Voltage	VCC	—	3.0	—	5.5	V	
Output Voltage	VOOUT	Driver Off <sup>*1</sup>	—	—	17	V	
Output Current	IO	OUTn, VCC=5V	5	—	90	mA	
	IOH	VOH = VCC – 0.2 V	—	—	+4		
	IOL	VOL = 0.2 V	—	—	-4		
Input Voltage	VIH	VCC = 3.3 V ~ 5V	0.7VCC	—	VCC	V	
	VIL		0.0	—	0.3VCC		
Input Clock Frequency	FCKI	Single Chip Operation	—	—	30	MHz	
		Cascade Operation	—	—	—		
LAT Pulse Width	twLAT	VCC = 5.0V	—	15	—	ns	
CLK Pulse Width	tw CLK		—	13	—		
EN Pulse Width	twEN		50	—	—		
Set-up Time for DAI	tsetup(D)		—	10	—		
Hold Time for DAI	thold(D)		—	10	—		
Set-up Time for LAT	tsetup(L)		—	10	—		
Hold Time for LAT	thold(L)		—	10	—		
Detection Response	tdet		—	—	100		—

<sup>\*1</sup> The driver output voltage including any overshoot stress has to be compliant with the maximum voltage (17V).

unless otherwise noted)

CHARACTERISTIC	SYMBOL	CONDITION	MIN.	TYP.	MAX.	UNIT
Input Voltage "H" Level	VIH	CMOS logic level	0.7VCC	—	VCC	V
Input Voltage "L" Level	VIL	CMOS logic level	GND	—	0.3VCC	
Output Leakage Current	IOL	VOH = 17 V	—	—	±1	uA
Output Voltage (S-OUT)	VOL	IOL = -4 mA	—	—	0.2	V
	VOH	IOH = 4 mA	VCC-0.2	—	—	
Output Current Skew (Channel-to-Channel) <sup>*1</sup>	IOL1	VOUT = 1.0 V Rrest = 3.9 KΩ	—	—	±3	%
Output Current Skew (Chip-to-Chip) <sup>*2</sup>	IOL2		—	—	±6	%
Output Voltage Regulation	% / VOUT	Rrest = 3.9 KΩ VOUT = 1 V ~ 3 V	—	±0.1	±0.5	% / V
Supply Voltage Regulation	% / VCC	Rrest = 3.9 KΩ	—	±1	±4	
Differential Linearity	DLE	Rrest = 3.9 KΩ	—	±1.5	—	LSB
Output Voltage Short to GND, LED Open Detection Threshold	V(od)	all outputs turn on	—	0.1	—	V
LED Short Detection Threshold <sup>*3</sup> (output turns on)		SV = "H"	—	VCC	—	V
	V(sd)	SV = "L"	—	5/6VCC	—	V
Thermal Threshold	T(130)	junction temperature	—	130	—	°C
	T(170)		—	170	—	
Thermal Shutdown Threshold	T(sht)		—	170	—	
Supply Current (Input signal is static)	IDD(off)	power on all pins are open unless VCC and GND	—	1.2	—	mA
	IDD(off)	Rrest = 3.9 KΩ all outputs turn off	—	7	—	
	IDD(on)	Rrest = 3.9 KΩ all outputs turn on	—	7.6	—	
	IDD(off)	Rrest = 820 Ω all outputs turn off	—	27.5	—	
	IDD(on)	Rrest = 820 Ω all outputs turn on	—	25.3	—	
	IDD(sleep)	Sleep current	—	5	50	uA

<sup>\*1</sup> Channel-to-channel skew is defined as the ratio between (any Iout – average Iout) and average Iout, where average Iout = (Imax + Imin) / 2.

<sup>\*2</sup> Chip-to-Chip skew is defined as the range into which any output current of any IC falls.

<sup>\*3</sup> LED short detection voltage level default value is VCC, refer to Page 12 for level selection.

**Switching Characteristics** (VCC = 5.0V, Ta = 25°C unless otherwise noted)

CHARACTERISTIC		SYMBOL	CONDITION	MIN.	TYP.	MAX.	UNIT	
Propagation Delay (‘L to ‘H’)	$\overline{EN}$ -to-OUT0	tpLH	VIH = VCC VIL = GND R <sub>rext</sub> = 3.9 KΩ VL = 5.0 V RL = 0.18 KΩ CL = 13 pF	—	26	—	ns	
	$\overline{LAT}$ -to-OUT0			—	31	—		
	CLK-to-DAO			—	19	—		
Propagation Delay (‘H’ to ‘L’)	$\overline{EN}$ -to-OUT0	tpHL		—	31	—		
	$\overline{LAT}$ -to-OUT0			—	32	—		
	CLK-to-DAO			—	20	—		
Output Current Rise Time		tor		—	10	—		
Output Current Fall Time		tof		—	10	—		
Output Delay Time (OUT <sub>(n)</sub> -to-OUT <sub>(n+1)</sub> )		tod		—	3	—		

**Switching Characteristics** (VCC = 3.3V, Ta = 25°C unless otherwise noted)

CHARACTERISTIC		SYMBOL	CONDITION	MIN.	TYP.	MAX.	UNIT	
Propagation Delay (‘L to ‘H’)	$\overline{EN}$ -to-OUT0	tpLH	VIH = VCC VIL = GND R <sub>rext</sub> = 3.9 KΩ VL = 5 V RL = 0.18 KΩ CL = 13 pF	—	36	—	ns	
	$\overline{LAT}$ -to-OUT0			—	37	—		
	CLK-to-DAO			—	22	—		
Propagation Delay (‘H’ to ‘L’)	$\overline{EN}$ -to-OUT0	tpHL		—	35	—		
	$\overline{LAT}$ -to-OUT0			—	37	—		
	CLK-to-DAO			—	23	—		
Output Current Rise Time		tor		—	14	—		
Output Current Fall Time		tof		—	14	—		
Output Delay Time (OUT <sub>(n)</sub> -to-OUT <sub>(n+1)</sub> )		tod		—	3	—		

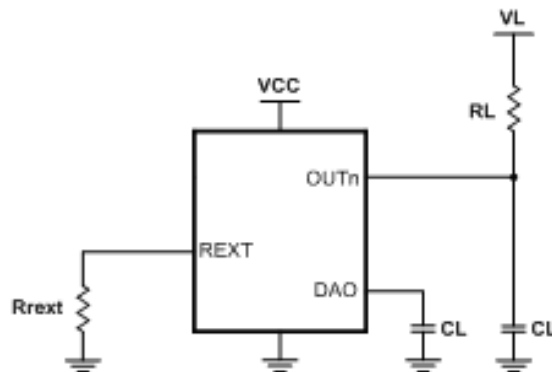

Switching Characteristics Test Circuit



## Timing Diagram

### 1. CLK-DAI, DAO

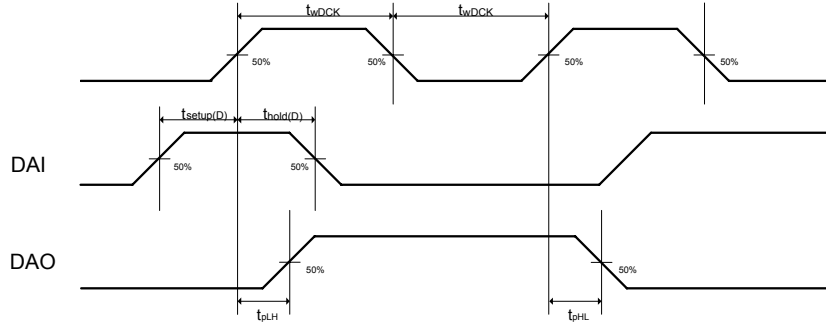

### 2. CLK-LAT

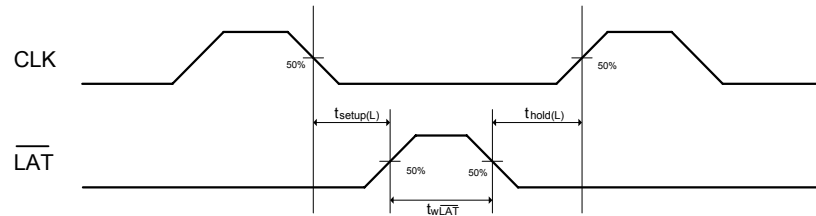

### 3. LAT-OUT0

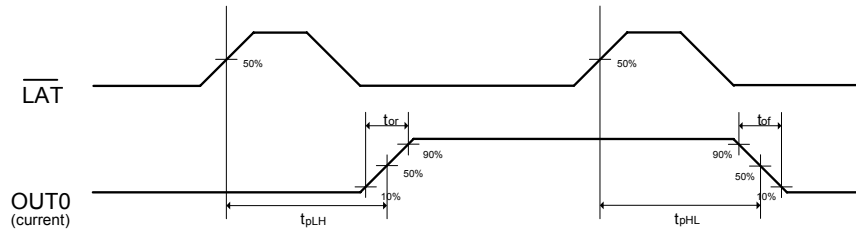

### 4. EN-OUT0

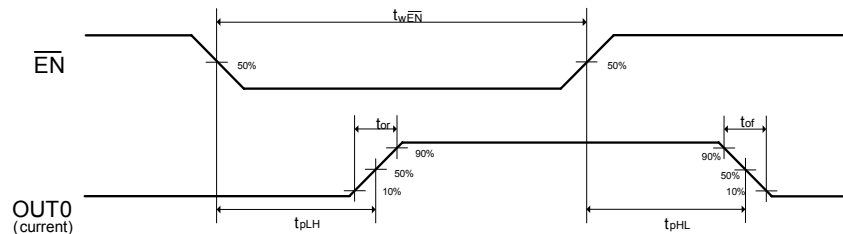

### 5. OUT<sub>n+1</sub>-OUT<sub>n</sub>

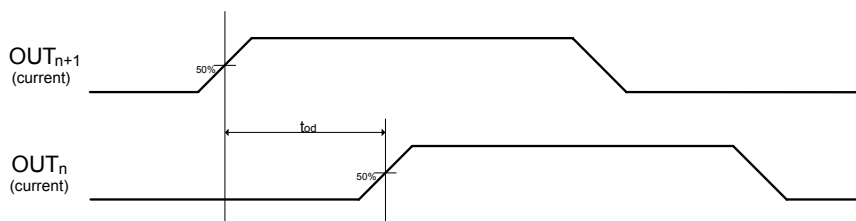

## Constant-Current Output

Constant-current value of each output channel is set by an external resistor connected between the REXT pin and GND. Varying the resistor value can adjust the current scale ranging from 5mA to 90mA. The reference voltage of REXT terminal ( $V_{\text{rext}}$ ) is approximately 1.23V. The output current value is calculated by the following equation:

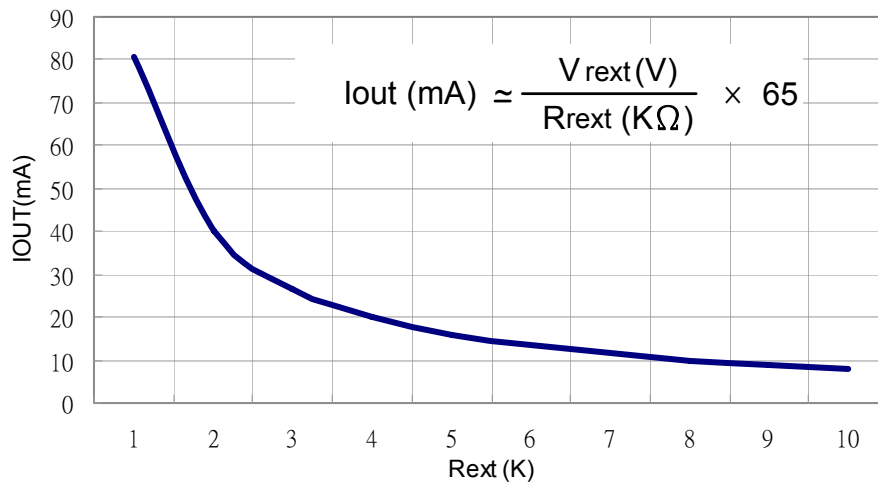

In order to obtain a good performance of constant-current output, a suitable output voltage is necessary. Users can get related information about the minimum output voltage below.

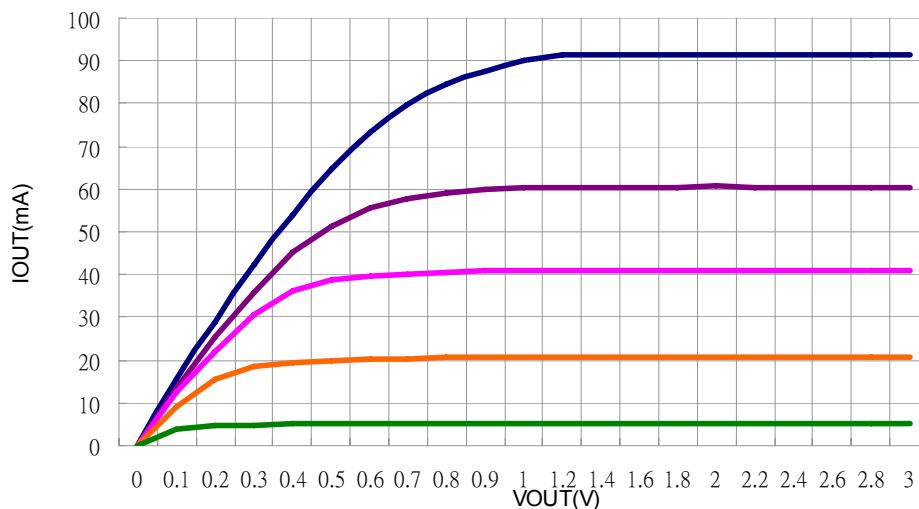

## Serial Data Interface

DM11H includes a flexible data transfer interface. The data can be transferred from DAI pin to the shift registers at the rising edge of CLK. After all data are clocked in, a rising edge of the  $\overline{\text{LAT}}$  signal can transfer the serial data to the data latches (Edge trigger). The serial data format can be 8-bit or 10-bit wide, depending on the operating mode of the device.

## Operation Mode

DM11H has two operating modes depending on the combination of CLK and  $\overline{\text{LAT}}$  signals. The table below shows the available operating modes. For normal operation (SD mode), the data width of shift register is 8-bit, which is used to set 8 bits serial-in image data. The sequence of the combination of CLK and  $\overline{\text{LAT}}$  explains in following pages is used to change the operation mode. If there are four triggering clock pulses (CLK) with high level latch ( $\overline{\text{LAT}}$ ), DM11H will change to command data input mode (CD mode) at falling edge of the latch pulse ( $\overline{\text{LAT}}$ ) then user can make ten triggering clock pulses to set 7-bit GBC data (default value after power-on is 7'b1000000), 2-bit voltage level selection of short detection (default value after power-on is 1'b10) and 1-bit sleep control data (default value is 1'b0)

OPERATION MODE	SHIFT REGISTER
Serial-in Data Input Mode (SD mode)	8-bit
Command Data Input Mode (CD mode)	10-bit

## SD Mode Data Format

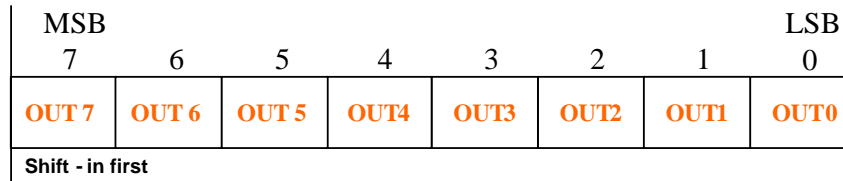

When DM11H operates at SD mode, the serial-in data (DAI) will be clocked into 8-bit shift register synchronized on the rising edge of the clock (CLK). The data '1' represents the corresponding current output 'ON', while the data '0' stands for 'OFF'. The data will be transferred into the 8-bit latch synchronized on the rising edge of the strobe signal ( $\overline{\text{LAT}}$ ); otherwise, the output data won't be changed. The latch pulse should be sent after the falling edge of the last clock within a frame data.

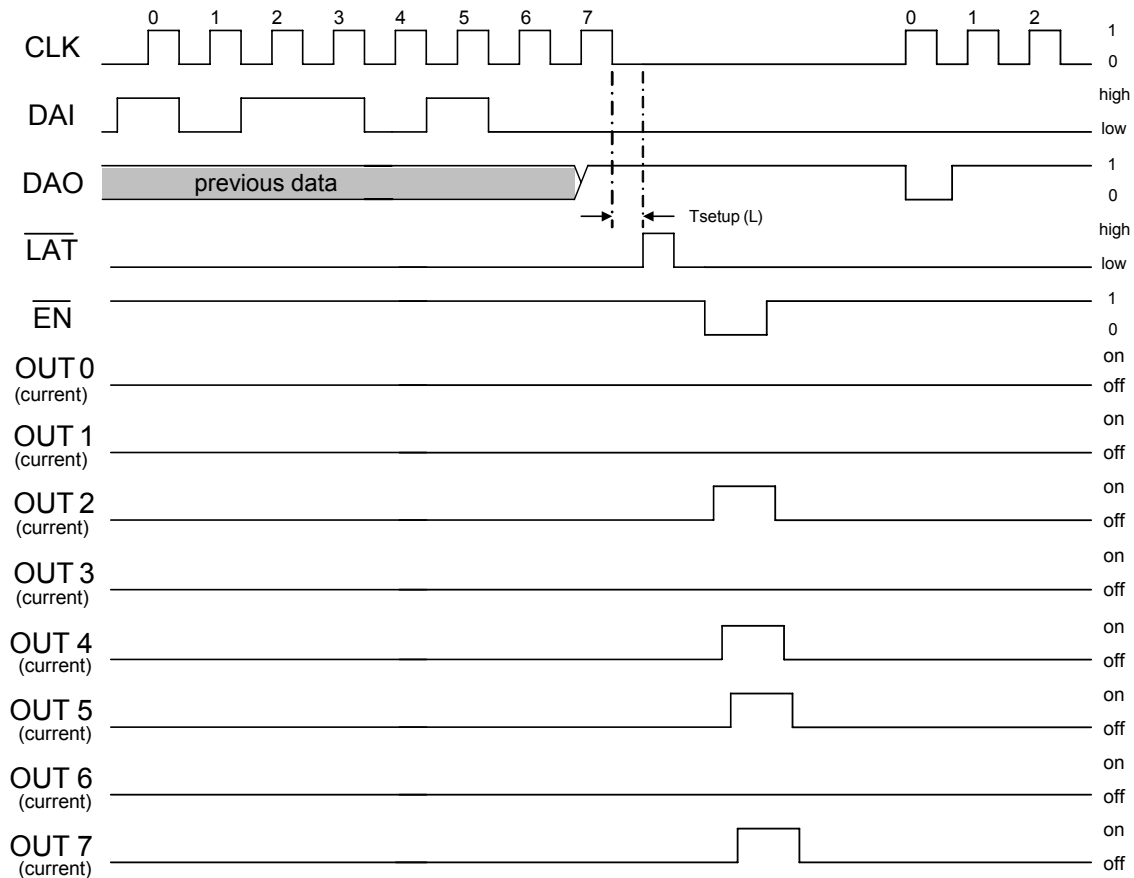

## CD Mode Data Format

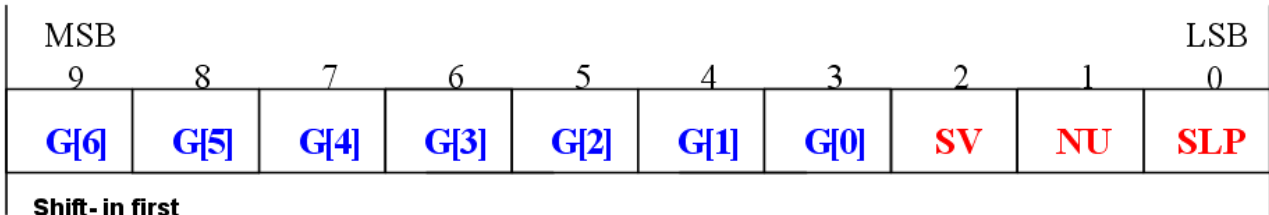

G[6:0] : Global Brightness Control   
 SV : LED short detection Level select   
 SLP : Sleep select  
NU : "0" for normal operation

### a. Global Brightness Control

DM11H offers a convenient way to fine tune the whole chip output currents for the uniformity of brightness between modules, ICs or the accommodation to ambient light. To further adjust the current level linearly, the system shall enter the CD MODE and then shift in 7-bit GBC data code through DAI pin. The MSB should be shifted-in first. Take the input code. G[6:0]= (MSB)1001011(LSB) for example. The new current is then equal to the base current multiplied by the ratio  $(2^6 + 2^3 + 2^1 + 2^0 + 1) / 128$ . The 7-bit data won't be changed until the next new data is latched. Note that the default code 7'b1000000 exists in chip memory when power on, so the output current is equal to the half of base current.

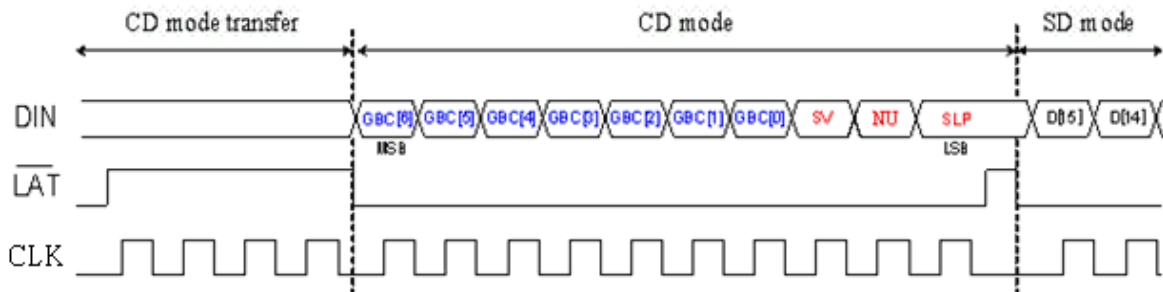

### b. Short detection voltage level selection

DM11H provides 2 voltage levels in coordination with LED short detection on system. VCC voltage level is the default value while power-on. DAO will send an error signal = H if the output voltage is greater than a respectively predetermined threshold value.

SV	Short Voltage
0	5/6 * VCC
1	VCC (default)

### c. Sleep mode

When SLP=1, DM11H will enter sleep mode, all outputs turn off and the IDD of DM11H will drop down to less than 5uA. This function is especially designed for battery or solar powered system.

## Error Detection

DM11H includes Real-time and Smart detection mode for LED open/short and driver outputs short to GND detection. It can be set as six types which are showing as following table.

Detection Type	Detection Operation
Real time LED Open Detection	CLK rising edge x1, with $\overline{LAT} = H$
Real time Output Short to GND Detection	CLK rising edge x2, with $\overline{LAT} = H$
Real time LED Short Detection	CLK rising edge x3, with $\overline{LAT} = H$
Smart LED Open Detection	CLK rising edge x1, with $\overline{LAT} = H$ then $\overline{LAT}$ falling edge x2 with CLK=H
Smart Output Short to GND Detection	CLK rising edge x2, with $\overline{LAT} = H$ then $\overline{LAT}$ falling edge x2 with CLK=H
Smart LED Short Detection	CLK rising edge x3, with $\overline{LAT} = H$ then $\overline{LAT}$ falling edge x2 with CLK=H

Selection of detection types is a collocation of CLK and  $\overline{LAT}$ . After detection executed, the error report will be saved in the particular shift register and could be retrieved from serial-out(DAO) data.

For Real-Time LED open/short detections, it's necessary to set the image data of the particular output channel as '1'. The serial-out data is '0' in the LED normal state, and the serial-out data will be '1' while a LED failure has occurred. If the image data is written to "0" or the output terminal is inactive ( $\overline{EN} = H$ ), it will not execute any detection process for the corresponding channel. Therefore, the serial-data will remain as "0".

For Real-Time Output Short to GND detection type, set the image data of the particular output channel to '0', outputs' state will be identified from DAO as above. In output normal state, the serial-out data is '0', but if the serial-out data is '1' then a DM11H output voltage lower than 0.2V. If the image data of particular channel is '1', no detection will be executed for the corresponding channel, and the serial-out data will be '0'. Otherwise, If output enable terminal is active ( $\overline{EN} = L$ ), the serial-out data will be '0'.

DM11H specializes in fast detection response, 100ns minima. Moreover, it offers multi selections like **Real-Time monitor** and **Smart detection**. Accordingly, it is more flexible and well adapted to the system requirements.

### a. Normal operation

When DM11H operates at normal operation (Latch only) the DAO pin will send out the original serial-in data not the error message.

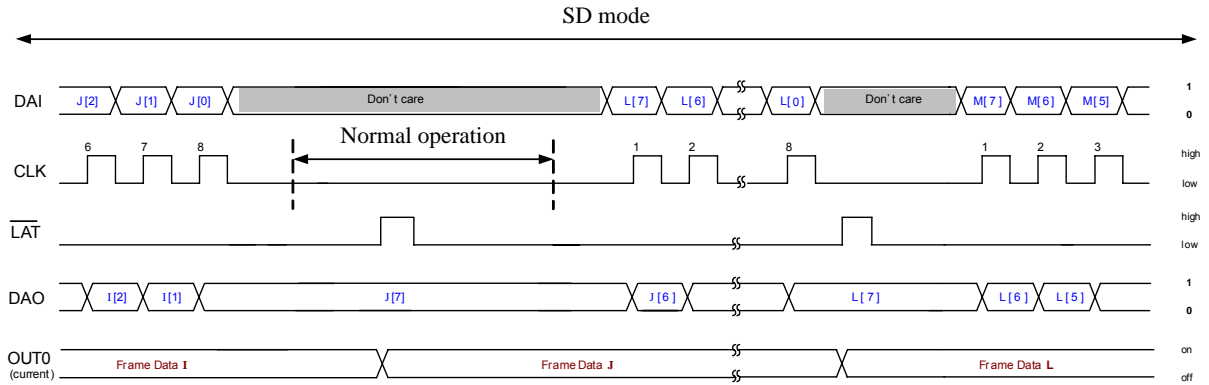

### b. LED Open/Short Detection(Real-time)

Set one CLK rising edge with  $\overline{\text{LAT}} = 'H'$  to operate Open Real-Time detection. Each channel will be identified as a LED open failure when there is a current passing through the output but the voltage is below 0.1V.

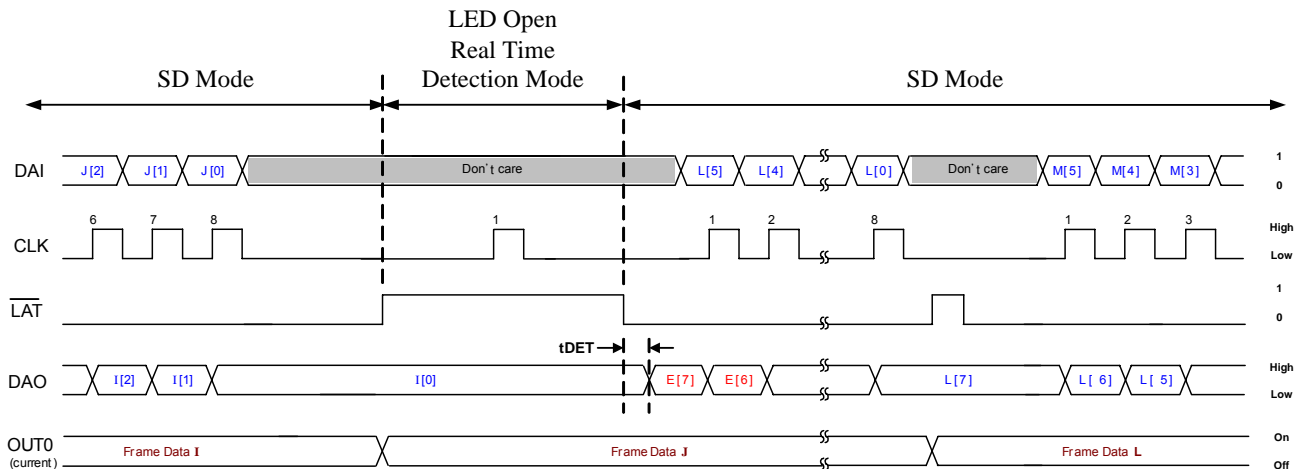

Set three CLK rising edges with  $\overline{\text{LAT}} = 'H'$  to operate Short Real-Time detection. A LED short failure will be identified when the output channel is on and the output voltage is higher VCC.

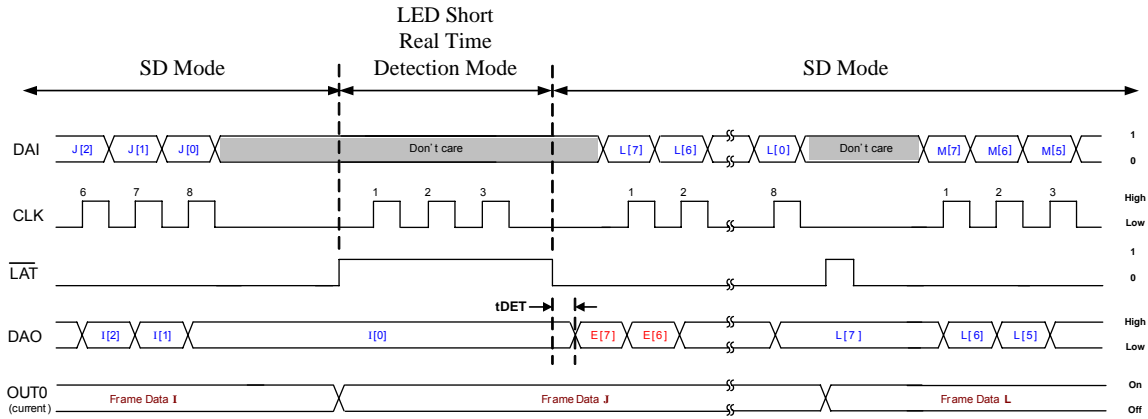

With the above operating principle, the controller could continuously retrieve LED status from serial-out(DAO) then compare with the last frame data one by one. Once there is any serial-out data at '1' be retrieved, it pinpoints the channel with failed LED. Since the process is ongoing and without shifting between image and detection mode, it does not interrupt the image data flow and the output display. This is known as “**Real-Time Monitor**”.

### c. LED Open/Short Detection(Smart Detection)

DM11H also specially provides another “**smart**” detection method. In Smart detection mode, DM11H will automatically turns on all output channels with  $I_{out}=50\mu A$  until the next rising edge of the CLK pulse. After the rising edge of CLK, the output current will return to original state. Notice that enable control ( $\overline{\text{EN}}$ ) won't affect smart detection result.

Set one CLK rising edge with  $\overline{\text{LAT}} = 'H'$  then two  $\overline{\text{LAT}}$  falling edges with CLK is 'H' to operate Open Smart detection. Each channel will be identified as a LED open failure when there is a current passing through the output but the voltage is below 0.1V.

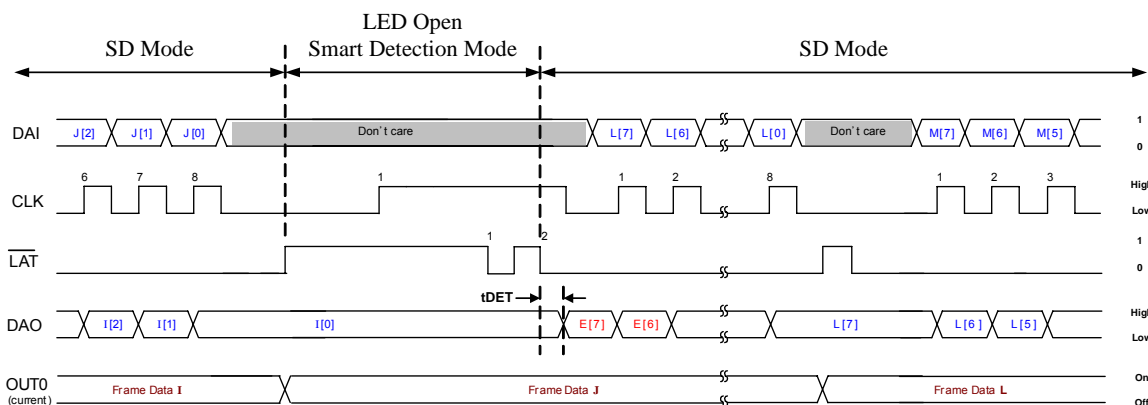



Set three CLK rising edges with  $\overline{\text{LAT}} = 'H'$  then two  $\overline{\text{LAT}}$  falling edges with CLK is 'H' to operate Short Smart detection. A LED short failure will be identified when the output channel is off and there is a current passing through the output but the voltage is above VCC.

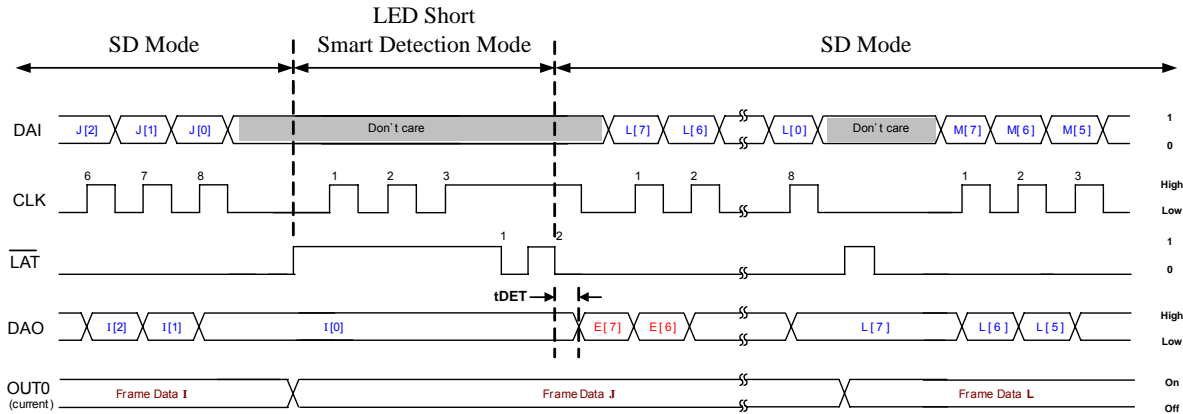

The error report of LED status will be retrieved from DAO. Once there is any serial-out data at '1' be retrieved, controller can counts clocks to identify the locations of fail LED. The impression of “invisible failure detection” is achievable because of less data clock-in cycle and small current during detection to avoid a flash. After Smart detection, DM11H will return to normal operation until next detection.

#### d. Outputs Short to GND Detection (Real-Time/Smart)

This error detection mode could detect the failure of IC and PCB. If IC output pins are burned-out or output pins on PCB layout are short to ground, the voltage of IC output pins would be pulled to low voltage. It will make LEDs turn on all the time. Therefore, DM11H would determine the failure of IC output pins when the output voltage is below 0.1V. For the duration of output short to GND smart detection, the output would be turned off automatically and pulled high to VDD no matter channel is on or off.

Set two CLK rising edges with  $\overline{\text{LAT}} = 'H'$  to operate Output Short to GND Real-Time detection. An output short failure will be identified when the output turn off but the voltage is below 0.1V.

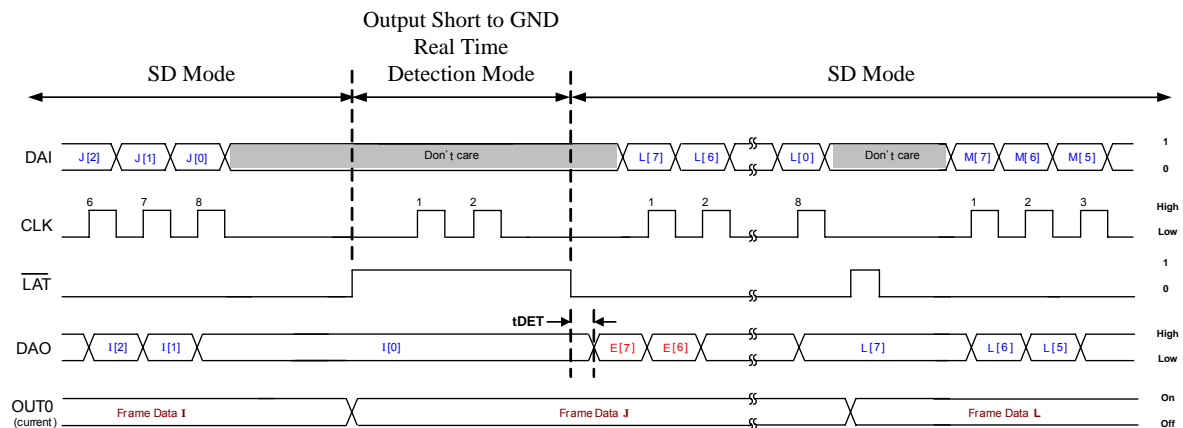

Set two CLK rising edges with  $\overline{\text{LAT}} = 'H'$  then sending two  $\overline{\text{LAT}}$  falling edges with CLK is 'H' to operate Output Short to GND Smart detection. DM11H will force all outputs to turn off automatically, and start to detect output short error until the next rising edge of CLK pulse. After the rising edge of CLK, the output current will return to original value. After the detection, device will return to Normal Operation. Notice that enable control ( $\overline{\text{EN}}$ ) won't affect smart detection result.

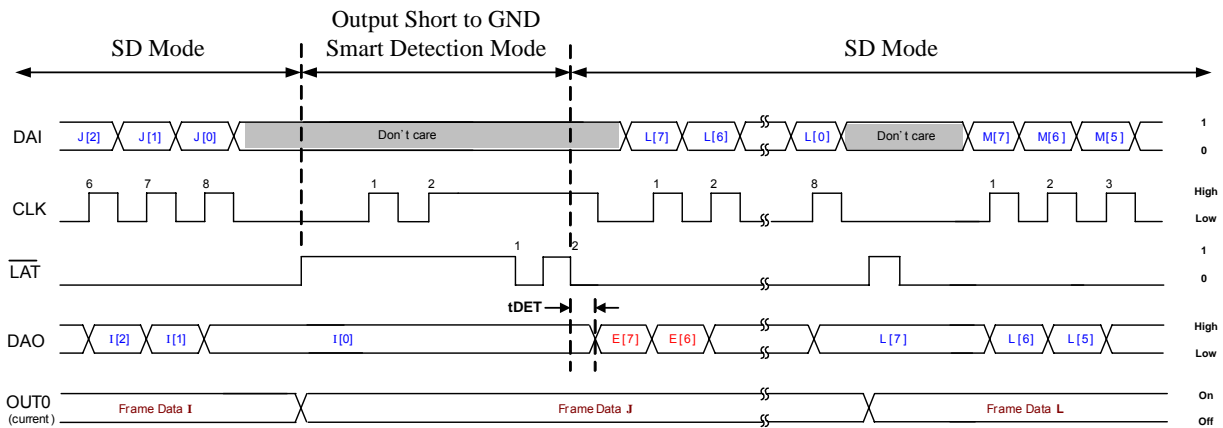

## Outputs Delay

Large in-rush currents will occur when the system activates all the outputs at once. To prevent this effect, a constant unit of delay between outputs is built-in DM11H. All outputs are divided into four groups and each group contains four outputs. For example, OUT0 ~ OUT3 form the group1; OUT4 ~ OUT7 form the group2. There is no delay between every group. But each output delay between channels in a group is 3ns @VDD=3.3V (typical).

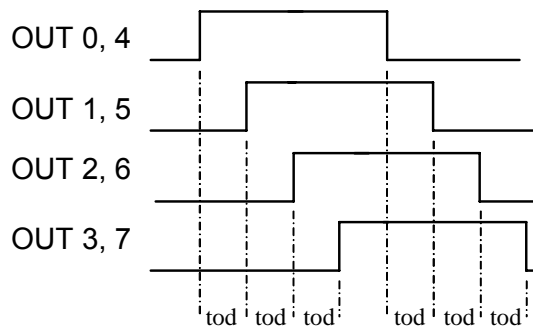

## Thermal Alarm and Shutdown

DM11H provides a temperature error detection circuit for thermal alarm and shutdown protection. When junction temperature of the IC exceeds 130°C, the thermal flag(T130) will be serial-out in the CD mode. If no cooling measures to reduce the temperature(by system), the junction temperature might continue to rise. Once it reaches to 170°C, DM11H will turn off all outputs. When the junction temperature is lower than 130°C, DM11H will restart automatically. Operation in the over-temperature situation( > 130°C) for a long time may cause chip damage permanently.

Thermal Flag	Description
T130	130°C temperature flag "H" : Temp $\geq$ 130°C ,      "L" : Temp < 130°C
T170	170°C temperature flag "H" : Temp $\geq$ 170°C ,      "L" : Temp < 170°C
Tshut	Shutdown Flag "H" : 8 outputs off,      "L" : normal operation

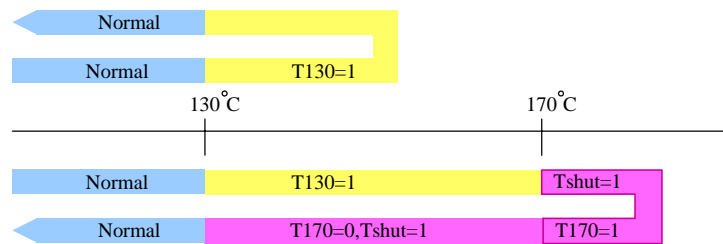

In CD mode, thermal flags will be serial-out through DAO. According to these thermal flags, the control system can adopt proper way to protect whole display system. Please note the thermal flags are all 'L' in normal operation.

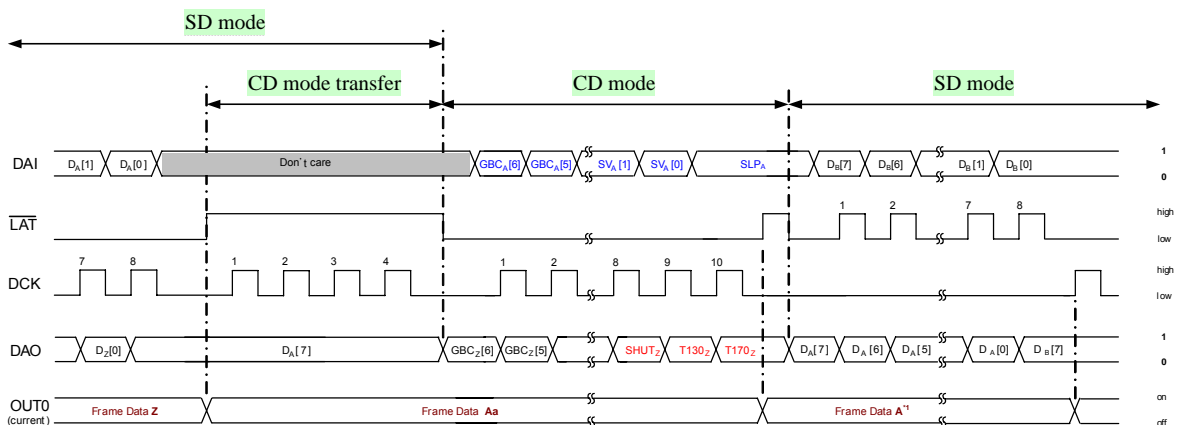

\*1 The difference between Frame data A and Aa is the max output current.

## Power Dissipation

Notice that the power dissipation of a semiconductor chip is limited to its package and ambient temperature, in which the device requires the maximum output current calculated for given operating conditions. The maximum allowable power consumption can be calculated by the following equation:

$$Pd(max)(Watt) = \frac{Tj(junction\ temperature)(max)(^{\circ}C) - Ta(ambient\ temperature)(^{\circ}C)}{Rth(junction-to-air\ thermal\ resistance)(^{\circ}C/Watt)}$$

The relationship between power dissipation and operating temperature can be refer to the figure below:

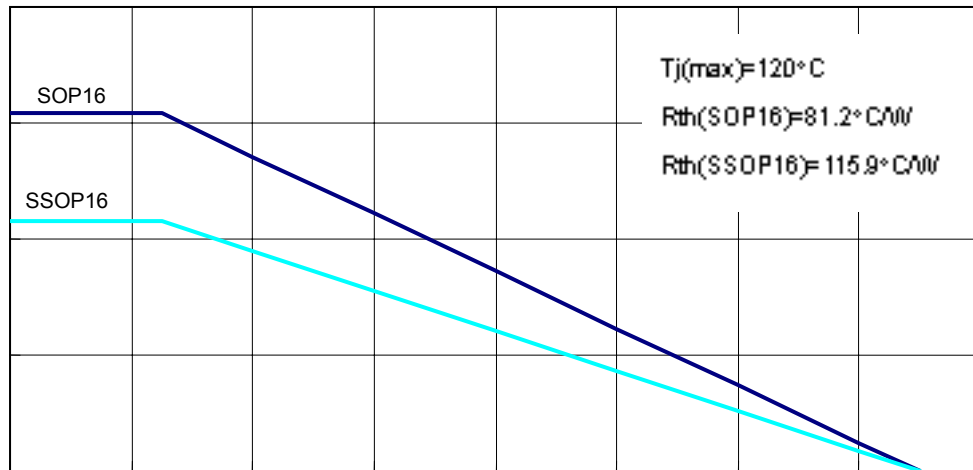

The power consumption of IC can be determined by the following equation and should be less than the maximum allowable power dissipation:

$$Pd(W) = Vcc(V) \times IdD(A) + Vout0 \times Iout0 \times Duty0 + \dots + Vout15 \times Iout15 \times Duty15 \leq Pd(max)(W)$$

## Package Outline Dimension

### SOP16 (exposed pad)

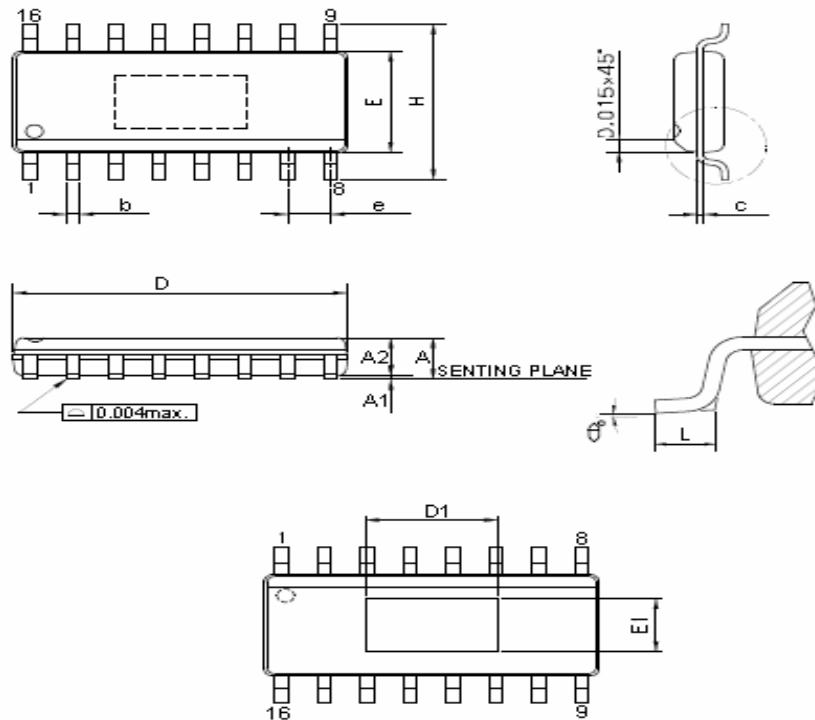

SYMBOL	DIMENSION IN MM			DIMENSION IN INCH		
	MIN	TYP	MAX	MIN	TYP	MAX
A	1.346	-	1.753	0.053	-	0.069
A1	0.051	-	0.152	0.002	-	0.006
A2	1.245	-	1.651	0.061		0.065
b	0.406 BSC			0.406 BSC		
c	0.203 BSC			0.203 BSC		
D	9.804	-	10.008	0.386	-	0.394
E	3.810	-	3.988	0.150	-	0.157
e	1.270 BSC			1.270 BSC		
H	5.791	-	6.198	0.228	-	0.244
L	0.406	-	1.270	0.016	-	0.050
θ°	0	-	8	0	-	8
PAD SIZE1 (95×18E)						
E1	1.930	-	2.413	0.076	-	0.095
D1	3.658	-	4.572	0.144	-	0.180

**SSOP16**

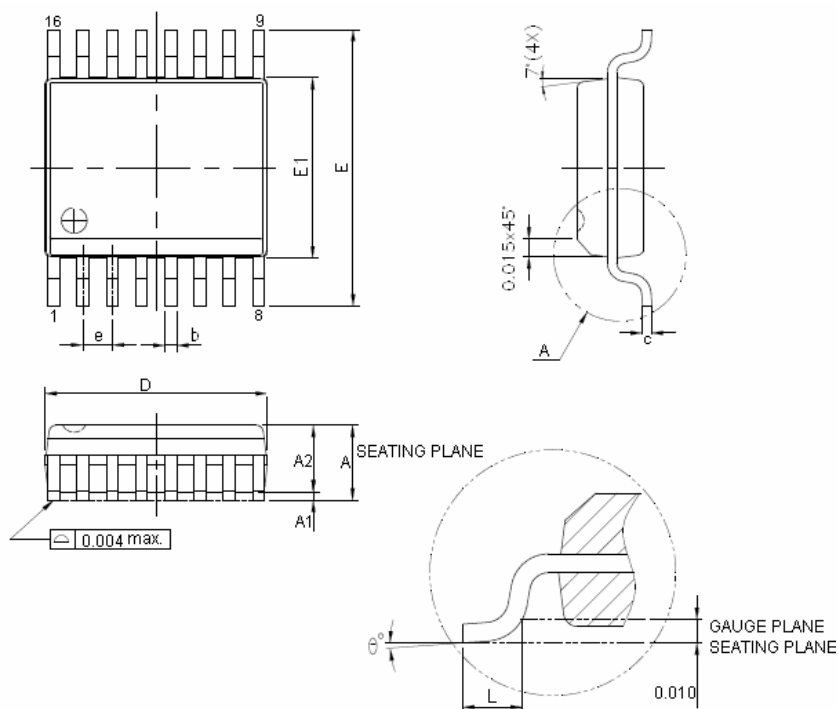

SYMBOLS	DIMENSIONS IN INCH			DIMENSIONS IN MM		
	MIN.	TYP.	MAX.	MIN.	TYP.	MAX.
A	0.053		0.069	1.346	-	1.753
A1	0.004		0.010	0.102	-	0.254
A2	0.049		0.059	1.245	-	1.499
b	0.007		0.012	0.190	-	0.305
c	0.007		0.014	0.178	-	0.350
D	0.189	0.193	0.197	4.801	4.902	5.004
E	0.228	-	0.244	5.791	-	6.200
e	0.025 BSC			0.635 BSC		
E1	0.150	-	0.157	3.800	-	4.000
L	0.016	-	0.050	0.400	-	1.270
$\theta^\circ$	0.000	-	8.000	0	-	8

The products listed herein are designed for ordinary electronic applications, such as electrical appliances, audio-visual equipment, communications devices and so on. Hence, it is advisable that the devices should not be used in medical instruments, surgical implants, aerospace machinery, nuclear power control systems, disaster/crime-prevention equipment and the like. Misusing those products may directly or indirectly endanger human life, or cause injury and property loss.

Silicon Touch Technology, Inc. will not take any responsibilities regarding the misuse of the products mentioned above. Anyone who purchases any products described herein with the above-mentioned intention or with such misused applications should accept full responsibility and indemnify. Silicon Touch Technology, Inc. and its distributors and all their officers and employees shall defend jointly and severally against any and all claims and litigation and all damages, cost and expenses associated with such intention and manipulation.