



**WINCOM TECH**  
盈达顺科技

# Wincom Tech CO., LTD.

**The LCD(M) Specialist**

CONTACT ADDRESS : 3F, Block 13, WangJingKeng Industrial Park,  
DaKan XiLi. NanShan, Shenzhen City,China.

Tel: 0086-755-83308729

Fax: 0086-755-83308659

E-mail: [craig.jiang@wincomlcd.com](mailto:craig.jiang@wincomlcd.com)



PART NO. : WC2002A-SFYLYHC06

FOR MESSRS. : \_\_\_\_\_

## CONTENTS

<i>NO.</i>	<i>ITEM</i>	<i>PAGE</i>
1.	COVER	1
2.	RECORD OF REVISION	2
3.	GENERAL SPECIFICATION	3
4.	MECHANICAL DATA	3
5.	ABSOLUTE MAXIMUM RATINGS	4
6.	ELECTRICAL CHARACTERISTICS	5
7.	OPTICAL CHARACTERISTICS	5
8.	OUTLINE DIMENSION	6~7
9.	BLOCK DIAGRAM	7
10	INTERFACE TIMING CHART	8~9
11	INSTRUCTION CODE	10~11
12	CHARACTER GENERATOR ROM	12
13	SPECIFICATION OF QUALITY ASSURANCE	13~17

ACCEPTED BY: .....

PROPOSED BY: .....

## RECORD OF REVISION

DATE	PAGE	SUMMARY
2008-8-12	6	Change the "106mm" to "108mm"
2009-6-19	6	Change the center of LCD "59mm" to "58mm"
2011-7-20	3	Change the controller to SPLC780

### **3. General specifications**

#### **3.1 General specifications**

PLEASE REFER TO:

“CUSTOMER ACCEPTANCE STANDARD SPECIFICATIONS (MS-10-10000)”.

#### **3.2 Quality Assurance and Warranty**

PLEASE REFER TO:

“QUALITY ASSURANCE MANUL (MS-10-10001)”.

#### **3.3 This individual specification is prior to general specifications**

### **4. Mechanical data**

- Display format: 20 characters x 2 lines
- LCD type: STN Positive, Yellow-Green mode , Transflective
- Backlight: Side LED, Yellow-Green ,
- Viewing angle: 6:00
- Data transfer: 8Bit Parallel
- LCD controller: SPLC780 or equivalent
- Module size: 116 x 37 x14 mm
- View area: 83 x 18.6 mm
- Dot size: 0.6 x 0.65 mm
- Dot pitch: 0.65 x 0.7 mm
- Driving method: 1/16 Duty, 1/5 Bias

## 5. Absolute maximum ratings

### 5.1 Electrical absolute maximum ratings

<i>I T E M</i>	<i>SYMBOL</i>	<i>MIN.</i>	<i>MAX.</i>	<i>UNIT</i>	<i>COMMENT</i>
INPUT VOLTAGE	V <sub>I</sub>	0	6	V	-----
STATIC ELECTRICITY	-----	-----	-----	V	
POWER SUPPLY FOR BACKLIGHT	V <sub>S</sub>	---	3.3	V <sub>rms</sub>	-----
	f <sub>FL</sub>	-----	-----	KHz	-----
STARTING VOLTAGE FOR BACKLIGHT	-----	-----	-----	V <sub>rms</sub>	Ta = 25°C
	-----	-----	-----	V <sub>rms</sub>	Ta = 25°C

### 5.2 Environmental absolute maximum ratings

<i>I T E M</i>	<i>OPERATING</i>		<i>STORAGE</i>		<i>COMMENT</i>
	<i>MIN.</i>	<i>MAX.</i>	<i>MIN.</i>	<i>MAX.</i>	
AMBIENT TEMPERATURE	-20°C	70°C	-30°C	80°C	-----
HUMIDITY	NOTE (2)		NOTE (2)		NO CONDENSATION
VIBRATION NOTE (3)	-----	0.5G	-----	2G	10~300Hz XYZ DIRECTIONS 1 Hr EACH
SHOCK NOTE (3)	-----	3G	-----	5G	10 msec XYZ DIRECTIONS 1 TIME EACH
CORROSIVE GAS	NOT ACCEPTABLE		NOT ACCEPTABLE		-----

NOTE (2): Ta ≅ 70°C: 75% RH MAX.

Ta > 70°C: ABSOLUTE HUMIDITY MUST BE LOWER THAN THE  
HUMIDITY OF 75% RH AT 70°C.

NOTE (3): 1G = 9.8 m/s<sup>2</sup>

## 6. Electrical characteristics

Ta = 25°C VDD = 5.0 V

ITEM	SYMBOL	CONDITION	MIN.	TYP.	MAX.	UNIT
Power supply voltage for circuit	VDD-VSS	-----	4.75	5.0	5.25	V
Power supply voltage for LCD drive	VDD-Vo	-----	-----	4.7	-----	V
Data input voltage	V <sub>IH</sub>	H LEVEL	0.7V <sub>DD</sub>	-----	V <sub>DD</sub> +0.3	V
	V <sub>IL</sub>	L LEVEL	-0.3	-----	0.2V <sub>DD</sub>	V
LCD display duty ratio	DUTY	-----	-----	1/16	-----	-----
LED BACKLIGHT	Ifp	I meson plus 10% Dutg cyele		----		mA
		Operating voltage	-----	3.0	3.2	V
		Forward current		30	40	mA
LED Lifetime	-----	V <sub>FL</sub> =3.0 V <sub>rms</sub> I <sub>FL</sub> =30mA	-----	100000	-----	Hr

**LED backlight:** Due to the LED backlight working current is XXX Max, and LED chips Vop may be different, Wincom will adjust the backlight resistor according to the LED chips Vop, to meet the brightness maximum.

## 7. Optical characteristics

Ta = 25°C VDD-Vo = 4.7V

ITEM	SYMBOL	CONDITION	MIN.	TYP.	MAX.	UNIT	NOTE
Viewing angle	Φ2-Φ1	K ≧ 2.0	-35	----	20	deg.	1
Contrast ratio	K	Φ = 10° θ = 0°	4.0	----	-----	-----	1
Response time (at 25°C)	tr (rise)	Φ = 10° θ = 0°	-----	----	250	ms	1
	tf (fall)	Φ = 10° θ = 0°	-----	----	250	ms	1
The brightness of backlighting source	B	DOTS ALL ON V <sub>FL</sub> = 3.0 V <sub>rms</sub> I <sub>FL</sub> =30mA	-----	----	-----	cd/m <sup>2</sup>	2

NOTE (1): SEE CUSTOMER ACCEPTANCE STANDARD SPECIFICATION FOR DEFINITION OF OPTICAL CHARACTERISTICS

NOTE (2): UNDER NORMAL TEMPERATURE AND HUMIDITY IN A DARK ROOM

# 8. Outline dimension

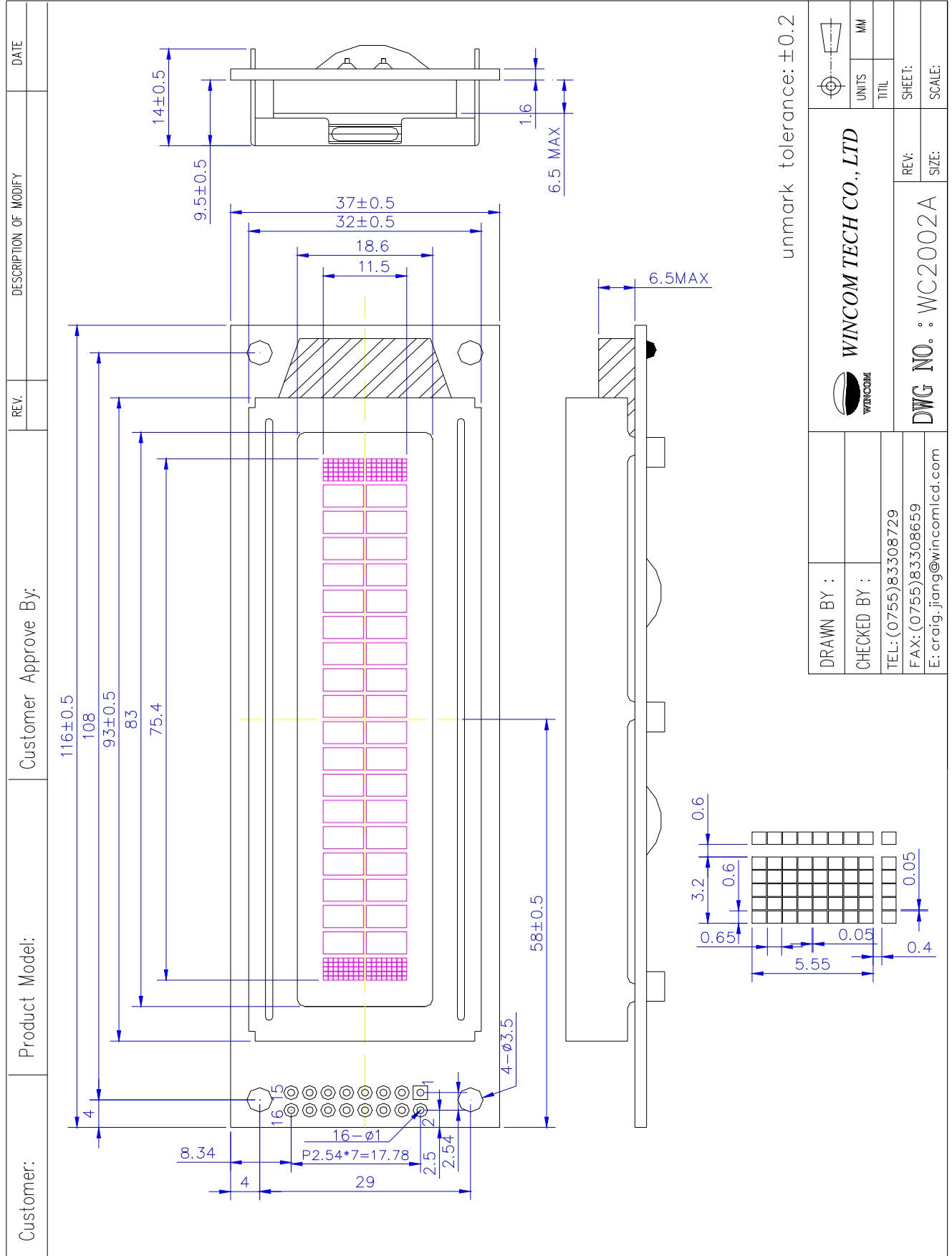

## 8.1 Interface

### Pin Assignment

PIN NO.	Symbol	Level	Function
1	VSS	0V	ground
2	VDD	5.0V	Power Supply for LCM(+)
3	V0	----	Contrast Adjust
4	RS	H/L	Register select signal
5	RW	H/L	Data read / write
6	E	H/L	Enable signal
7	DB0	H/L	Data bus line
8	DB1	H/L	Data bus line
9	DB2	H/L	Data bus line
10	DB3	H/L	Data bus line
11	DB4	H/L	Data bus line
12	DB5	H/L	Data bus line
13	DB6	H/L	Data bus line
14	DB7	H/L	Data bus line
15	A	+5.0V	Power Supply for Backlight “+”
16	K	0	Power Supply for Backlight “-”

## 9. Block diagram

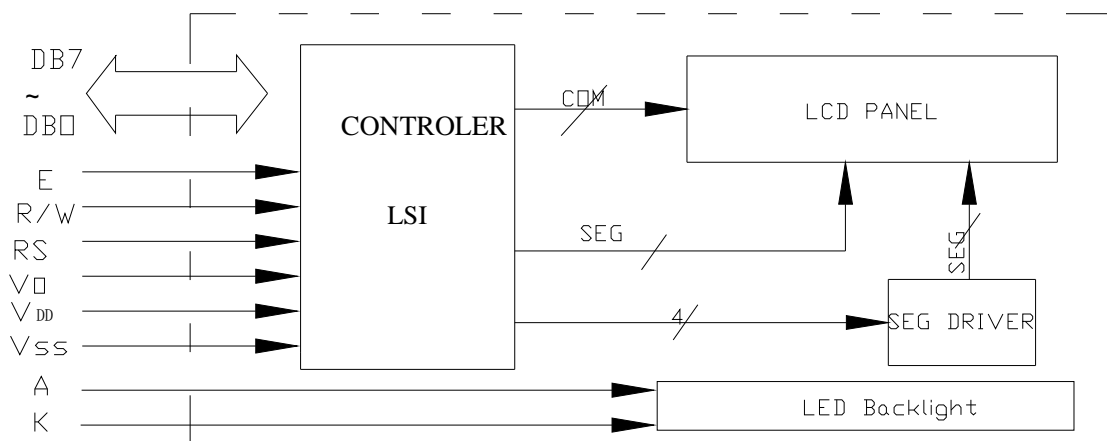

## Power for LCM

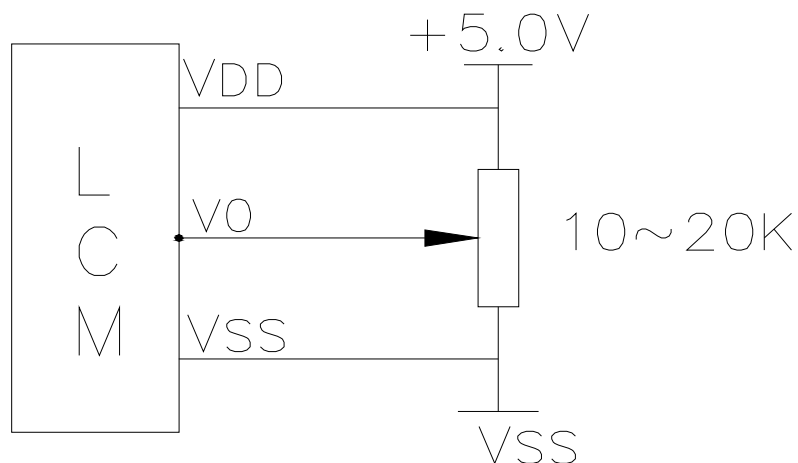

## 10.Interface Timing Chart

AC Characteristics( $V_{DD}=4.5V\sim 5.5V, T_a=-30\sim +85^{\circ}C$  )

Mode	Characteristic	Symbol	Min.	Typ.	Max.	Unit
Write Mode (Refer to Fig-6)	E Cycle Time	$t_c$	500	-	-	ns
	E Rise / Fall Time	$t_{R,t_F}$	-	-	20	
	E Pulse Width (High, Low)	$t_w$	230	-	-	
	R/W and RS Setup Time	$t_{su1}$	40	-	-	
	R/W and RS Hold Time	$t_{H1}$	10	-	-	
	Data Setup Time	$t_{su2}$	80	-	-	
	Data Hold Time	$t_{H2}$	10	-	-	
Read Mode (Refer to Fig-7)	E Cycle Time	$t_c$	500	-	-	ns
	E Rise / Fall Time	$t_{R,t_F}$	-	-	20	
	E Pulse Width (High, Low)	$t_w$	230	-	-	
	R/W and RS Setup Time	$t_{su}$	40	-	-	
	R/W and RS Hold Time	$t_H$	10	-	-	
	Data Output Delay Time	$t_D$	-	-	120	
	Data Hold Time	$t_{DH}$	5	-	-	



## Timing Characteristics

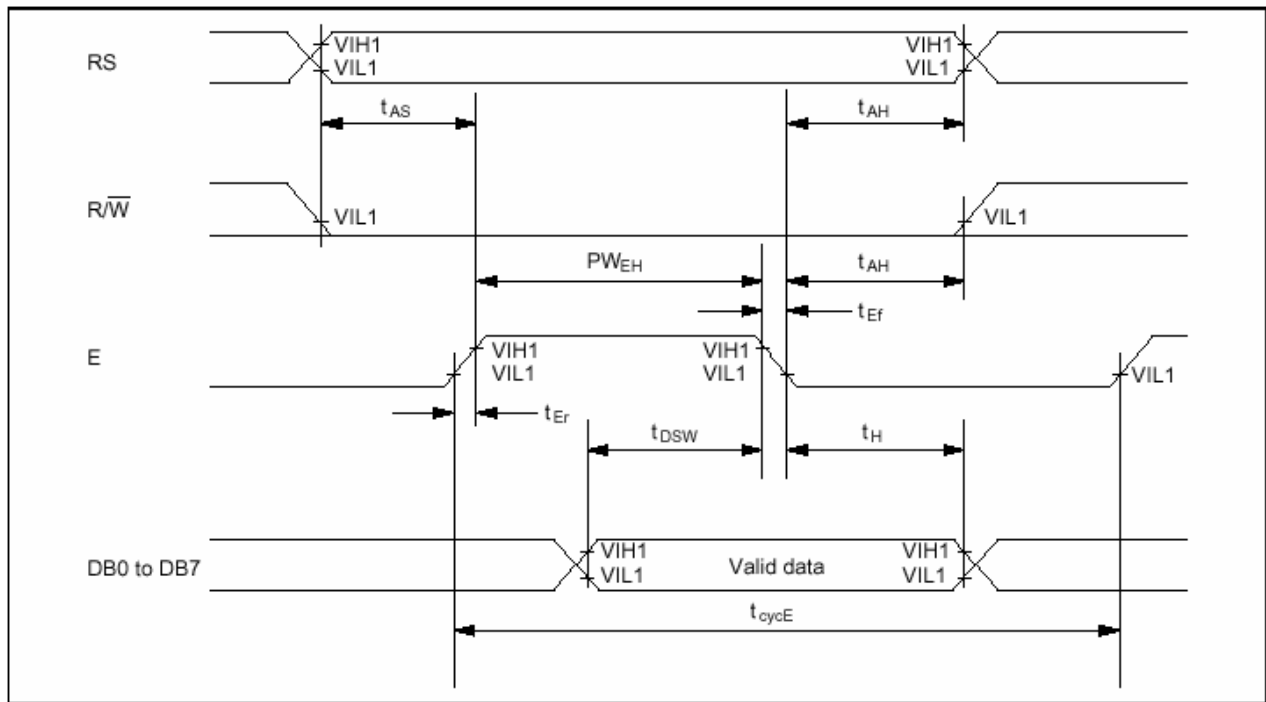

**Write Operation**

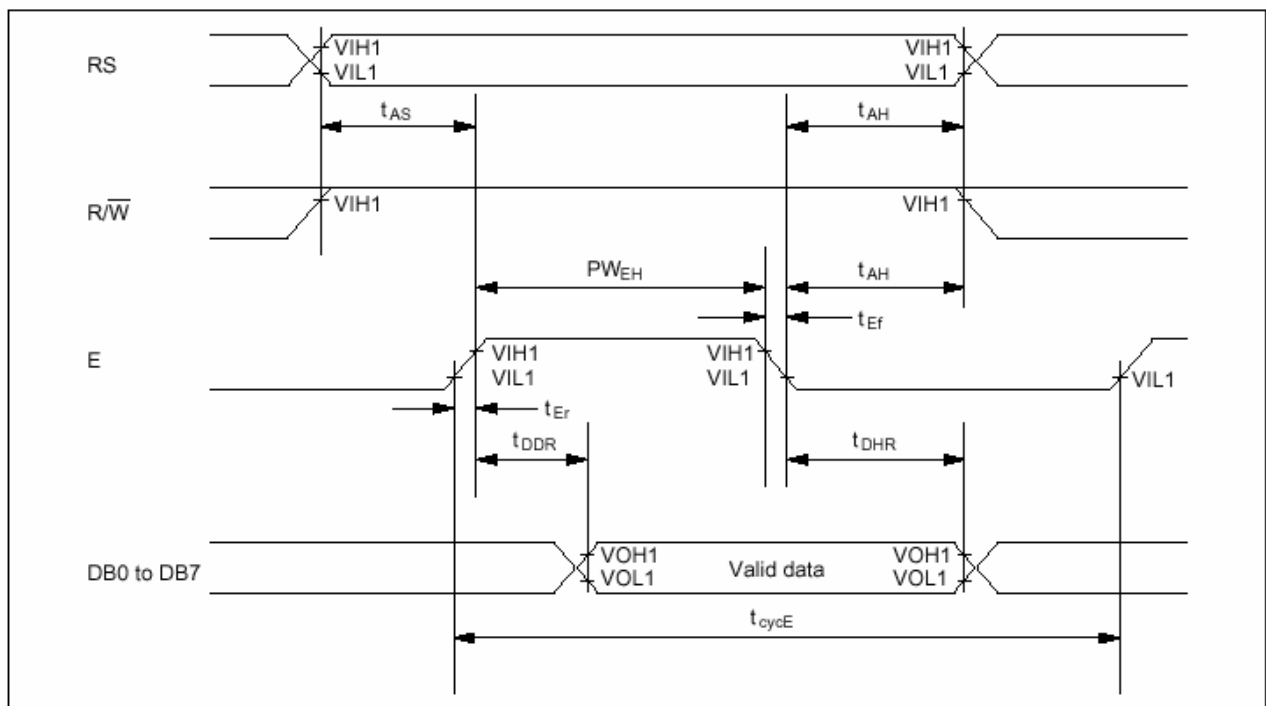

**Read Operation**

## 11. Instruction Code

Instruction Table

Instruction	Instruction Code										Description	Execution time (fosc= 270 kHz)	
	RS	R/W	DB7	DB6	DB5	DB4	DB3	DB2	DB1	DB0			
Clear Display	0	0	0	0	0	0	0	0	0	1	Write "20H" to DDRAM and set DDRAM address to "00H" from AC	1.53 ms	
Return Home	0	0	0	0	0	0	0	0	0	1	-	Set DDRAM address to "00H" from AC and return cursor to its original position if shifted. The contents of DDRAM are not changed.	1.53 ms
Entry Mode Set	0	0	0	0	0	0	0	0	1	I/D	SH	Assign cursor moving direction and enable the shift of entire display.	39 μs
Display ON/OFF Control	0	0	0	0	0	0	0	1	D	C	B	Set display(D), cursor(C), and blinking of cursor(B) on/off control bit.	39 μs
Cursor or Display Shift	0	0	0	0	0	0	1	S/C	R/L	-	-	Set cursor moving and display shift control bit, and the direction, without changing of DDRAM data.	39 μs
Function Set	0	0	0	0	0	1	DL	N	F	-	-	Set interface data length (DL: 8-bit/4-bit), numbers of display line (N: 2-line/1-line) and, display font type (F:5×11dots/5×8 dots)	39 μs
Set CGRAM Address	0	0	0	1	AC5	AC4	AC3	AC2	AC1	AC0		Set CGRAM address in address counter.	39 μs
Set DDRAM Address	0	0	1	AC6	AC5	AC4	AC3	AC2	AC1	AC0		Set DDRAM address in address counter.	39 μs
Read Busy Flag and Address	0	1	BF	AC6	AC5	AC4	AC3	AC2	AC1	AC0		Whether during internal operation or not can be known by reading BF. The contents of address counter can also be read.	0 μs
Write Data to RAM	1	0	D7	D6	D5	D4	D3	D2	D1	D0		Write data into internal RAM (DDRAM/CGRAM).	43 μs
Read Data from RAM	1	1	D7	D6	D5	D4	D3	D2	D1	D0		Read data from internal RAM (DDRAM/CGRAM).	43 μs

\* "-": don't care

NOTE: When an MPU program with checking the Busy Flag(DB7) is made, it must be necessary 1/2Fosc is necessary for executing the next instruction by the falling edge of the 'E' signal after the Busy Flag (DB7) goes to "Low".

8-bit interface mode (Condition: fosc = 270KHZ)

Power on

Wait for more than 30 ms  
after VDD rises to 4.5 v

Function set									
RS	R/W	DB7	DB6	DB5	DB4	DB3	DB2	DB1	DB0
0	0	0	0	1	1	N	F	X	X

Wait for more than 39 μs

Display ON/OFF Control									
RS	R/W	DB7	DB6	DB5	DB4	DB3	DB2	DB1	DB0
0	0	0	0	0	0	1	D	C	B

Wait for more than 39 μs

Display Clear									
RS	R/W	DB7	DB6	DB5	DB4	DB3	DB2	DB1	DB0
0	0	0	0	0	0	0	0	0	1

Wait for more than 1.53 ms

Entry Mode Set									
RS	R/W	DB7	DB6	DB5	DB4	DB3	DB2	DB1	DB0
0	0	0	0	0	0	0	1	I/D	SH

Initialization end

N	0	1-line mode
	1	2-line mode

F	0	display off
	1	display on

D	0	display off
	1	display on

C	0	cursor off
	1	cursor on

B	0	blink off
	1	blink on

I/D	0	decrement mode
	1	increment mode

SH	0	entire shift off
	1	entire shift on

## 12.Character generator ROM

Lower 4 Bits \ Upper 4 Bits	0000	0010	0011	0100	0101	0110	0111	1010	1011	1100	1101	1110	1111
xxxx0000	CG RAM (1)		Ø	Q	P	`	P		-	タ	三	α	ρ
xxxx0001	(2)	!	1	A	Q	a	q	。	ア	チ	△	ä	g
xxxx0010	(3)	"	2	B	R	b	r	「	イ	ツ	×	ß	θ
xxxx0011	(4)	#	3	C	S	c	s	」	ウ	テ	モ	ε	ω
xxxx0100	(5)	\$	4	D	T	d	t	、	エ	ト	ト	μ	Ω
xxxx0101	(6)	%	5	E	U	e	u	・	オ	ナ	1	ε	ü
xxxx0110	(7)	&	6	F	V	f	v	ヲ	カ	ニ	ヨ	ρ	Σ
xxxx0111	(8)	'	7	G	W	g	w	ア	キ	ヌ	ラ	g	π
xxxx1000	(1)	(	8	H	X	h	x	イ	ク	ネ	リ	r	×
xxxx1001	(2)	)	9	I	Y	i	y	ウ	ケ	ル		´	y
xxxx1010	(3)	*	:	J	Z	j	z	エ	コ	ン	レ	j	¥
xxxx1011	(4)	+	;	K	C	k	c	オ	サ	ヒ	ロ	*	万
xxxx1100	(5)	,	<	L	¥	l	l	ヤ	シ	フ	ワ	φ	円
xxxx1101	(6)	-	=	M	J	m	j	ユ	ズ	ン	シ	も	÷
xxxx1110	(7)	.	>	N	^	n	→	ヨ	セ	ホ	°	ñ	
xxxx1111	(8)	/	?	O	_	o	←	ッ	ソ	マ	°	ö	■

### 13. Specification of quality assurance

AQL inspection standard

Sampling method: MIL-STD-105E, Level II, single sampling

Defect classification (**Note: \* is not including**)

Classify	Item	Note	AQL	
Major	Display state	Short or open circuit	1	0.65
		LC leakage		
		Flickering		
		No display		
		Wrong viewing direction		
		Contrast defect (dim, ghost)		
		Back-light	1,8	
	Non-display	Flat cable or pin reverse	10	
		Wrong or missing component	11	
Minor	Display state	Background color deviation	2	1.0
		Black spot and dust	3	
		Line defect, Scratch	4	
		Rainbow	5	
		Chip	6	
		Pin hole	7	
	Polarizer	Protruded	12	
		Bubble and foreign material	3	
	Soldering	Poor connection	9	
	Wire	Poor connection	10	
	TAB	Position, Bonding strength	13	

**Note on defect classification**

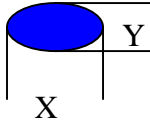
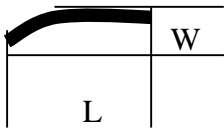
No.	Item	Criterion																			
1	Short or open circuit	Not allow																			
	LC leakage																				
	Flickering																				
	No display																				
	Wrong viewing direction																				
	Wrong Back-light																				
2	Contrast defect	Refer to approval sample																			
	Background color deviation																				
3	Point defect, Black spot, dust (including Polarizer)  $\phi = (X+Y)/2$	<table border="1"> <thead> <tr> <th>Point Size</th> <th>Acceptable Qty.</th> </tr> </thead> <tbody> <tr> <td><math>\phi &lt; 0.10</math></td> <td>Disregard</td> </tr> <tr> <td><math>0.10 &lt; \phi \leq 0.20</math></td> <td>3</td> </tr> <tr> <td><math>0.20 &lt; \phi \leq 0.25</math></td> <td>2</td> </tr> <tr> <td><math>0.25 &lt; \phi \leq 0.30</math></td> <td>1</td> </tr> <tr> <td><math>\phi &gt; 0.30</math></td> <td>0</td> </tr> </tbody> </table>	Point Size	Acceptable Qty.	$\phi < 0.10$	Disregard	$0.10 < \phi \leq 0.20$	3	$0.20 < \phi \leq 0.25$	2	$0.25 < \phi \leq 0.30$	1	$\phi > 0.30$	0							
		Point Size	Acceptable Qty.																		
		$\phi < 0.10$	Disregard																		
		$0.10 < \phi \leq 0.20$	3																		
		$0.20 < \phi \leq 0.25$	2																		
		$0.25 < \phi \leq 0.30$	1																		
$\phi > 0.30$	0																				
																					
Unit:mm																					
4	Line defect, Scratch	<table border="1"> <thead> <tr> <th colspan="2">Line</th> <th rowspan="2">Acceptable Qty.</th> </tr> <tr> <th>L</th> <th>W</th> </tr> </thead> <tbody> <tr> <td>---</td> <td><math>0.015 \geq W</math></td> <td>Disregard</td> </tr> <tr> <td><math>3.0 \geq L</math></td> <td><math>0.03 \geq W</math></td> <td rowspan="2">2</td> </tr> <tr> <td><math>2.0 \geq L</math></td> <td><math>.05 \geq W</math></td> </tr> <tr> <td><math>1.0 \geq L</math></td> <td><math>0.1 &gt; W</math></td> <td>1</td> </tr> <tr> <td>---</td> <td><math>0.05 &lt; W</math></td> <td>Applied as point defect</td> </tr> </tbody> </table>	Line		Acceptable Qty.	L	W	---	$0.015 \geq W$	Disregard	$3.0 \geq L$	$0.03 \geq W$	2	$2.0 \geq L$	$.05 \geq W$	$1.0 \geq L$	$0.1 > W$	1	---	$0.05 < W$	Applied as point defect
		Line		Acceptable Qty.																	
		L	W																		
		---	$0.015 \geq W$	Disregard																	
		$3.0 \geq L$	$0.03 \geq W$	2																	
		$2.0 \geq L$	$.05 \geq W$																		
$1.0 \geq L$	$0.1 > W$	1																			
---	$0.05 < W$	Applied as point defect																			
																					
5	Rainbow	Not more than two color changes across the viewing area.																			

NO.	Item	Criterion
-----	------	-----------

6

Chip

Remark:

X: Length direction

Y: Short direction

Z: Thickness direction

t: Glass thickness

W: Terminal Width

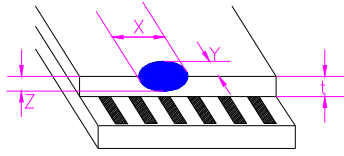

Acceptable criterion		
X	Y	Z
$\leq 2$	0.5mm	$\leq t/2$

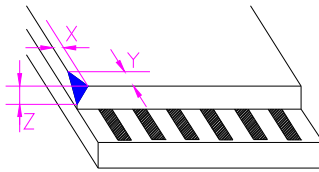

Acceptable criterion		
X	Y	Z
$\leq 2$	0.5mm	$\leq t$

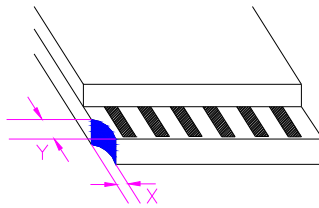

Acceptable criterion		
X	Y	Z
$\leq 3$	$\leq 2$	$\leq t$
shall not reach to ITO		

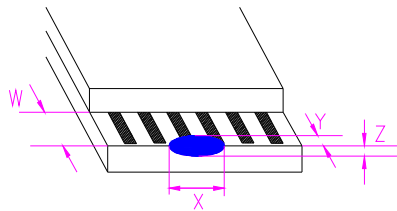

Acceptable criterion		
X	Y	Z
Disregard	$\leq 0.2$	$\leq t$

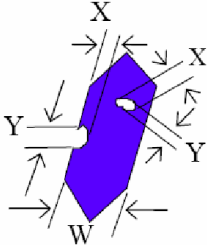
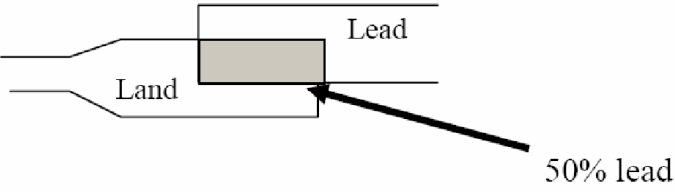
7	<p>Segment pattern</p> <p><math>W = \text{Segment width}</math></p> <p><math>\phi = (X+Y)/2</math></p>	<p>(1) Pin hole  <math>\phi &lt; 0.10\text{mm}</math> is acceptable.</p>  <table border="1" data-bbox="1029 212 1468 380"> <thead> <tr> <th>Point Size</th> <th>Acceptable Qty</th> </tr> </thead> <tbody> <tr> <td><math>\phi \leq 1/4W</math></td> <td>Disregard</td> </tr> <tr> <td><math>1/4W &lt; \phi \leq 1/2W</math></td> <td>1</td> </tr> <tr> <td><math>\phi &gt; 1/2W</math></td> <td>0</td> </tr> </tbody> </table> <p>Unit: mm</p>	Point Size	Acceptable Qty	$\phi \leq 1/4W$	Disregard	$1/4W < \phi \leq 1/2W$	1	$\phi > 1/2W$	0
Point Size	Acceptable Qty									
$\phi \leq 1/4W$	Disregard									
$1/4W < \phi \leq 1/2W$	1									
$\phi > 1/2W$	0									
8	Back-light	<p>(1) The color of backlight should correspond its specification.</p> <p>(2) Not allow flickering</p>								
9	Soldering	<p>(1) Not allow heavy dirty and solder ball on PCB.          (The size of dirty refer to point and dust defect)</p> <p>(2) Over 50% of lead should be soldered on Land.</p> 								
10	Wire	<p>(1) Copper wire should not be rusted</p> <p>(2) Not allow crack on copper wire connection.</p> <p>(3) Not allow reversing the position of the flat cable.</p> <p>(4) Not allow exposed copper wire inside the flat cable.</p>								
11*	PCB	<p>(1) Not allow screw rust or damage.</p> <p>(2) Not allow missing or wrong putting of component.</p>								

NO.	Item	Criterion
-----	------	-----------

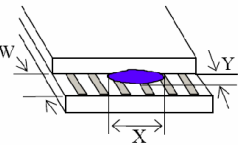
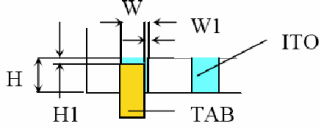
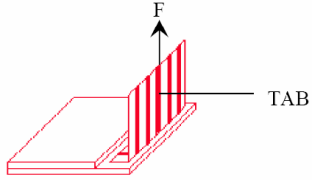

12	Protruded W: Terminal Width	 <p>Acceptable criteria: <math>Y \leq 0.4</math></p>
13	TAB	<p>1. Position</p>  <p><math>W1 \leq 1/3W</math> <math>H1 \leq 1/3H</math></p> <p>2 TAB bonding strength test</p>  <p><math>P (=F/TAB \text{ bonding width}) \geq 650\text{gf/cm}</math>, (speed rate: 1mm/min) 5pcs per SOA (shipment)</p>
14	Total no. of acceptable Defect	<p>A. Zone Maximum 2 minor non-conformities per one unit. Defect distance: each point to be separated over 10mm</p> <p>B. Zone It is acceptable when it is no trouble for quality and assembly in customer's end product.</p>