

|  |        |              |      |
|--|--------|--------------|------|
| <b>Shenzhen P&amp;O Technology Co.,Limited</b> | Rev No | Issued Date. | Page |
|  | A      | 2021.11.01   | 1/18 |

|                        |                         |          |
|------------------------|-------------------------|----------|
| Project Size.          | 4.3 inch                |          |
| Model No.              | P043C025-40-V3-RTP      |          |
| Samples No.            |                         |          |
| Product type.          | 480xRGBx272<br>RGB mode |          |
| Signature by customer: |                         |          |
| Prepared               | Checked                 | Approved |
|                        |                         |          |

## Shenzhen P&O Technology Co.,Limited

Email: polcd@polcd.com

Mobile: 86-136 0019 7172

## 1.0 GENERAL DESCRIPTION

### 1.1 Introduction

Display model P043C025-40-V3-RTP is a (TM)Transmissive type color active matrix thin Film transistor(TFT) liquid crystal display (LCD) that uses amorphous silicon TFT as a switching device. This model is composed of a TFT LCD panel, a driving circuit, a back light system. The resolution of a 4.3" contains 480<sub>RGB</sub>x272 dots and can display up to 262k colors.

| Item                          | Specification               | Unit     |
|-------------------------------|-----------------------------|----------|
| Screen Size                   | 4.3" inch                   | Diagonal |
| Number of Pixel               | 480RGB(H)x272(V)            | Pixels   |
| Display area                  | 95.04(H)x53.86(V)           | mm       |
| Pixel pitch                   | 66(H)x198(V)                | um       |
| Outline Dimension             | 105.50x67.15x4.12           | mm       |
| Pixel arrangement             | RGB Vertical Stripe         | ---      |
| Display mode                  | Normally Black/Transmissive | ---      |
| Viewing Direction(eye)        | 6 o'clock                   | ---      |
| Gray inversion direction      | --                          |          |
| Display Color                 | 262k                        | ---      |
| Luminance(cd/m <sup>2</sup> ) | 300                         | nit      |
| Contrast Ratio                | 500:1                       | ---      |
| Surface treatment             | ---                         | ---      |
| Interface                     | RGB 24bit                   |          |
| Back-light                    | LED Side-light type         | ---      |
| Drive IC                      | ILI6485                     |          |
| Operation Temperature         | -20~70                      | °C       |
| Storage Temperature           | -30~80                      | °C       |
| Weight                        | ---                         | g        |
|                               |                             |          |

### 1.2 Features

- RGB 24bit parallel interface.

### 1.3 Applications

- MPOS Device.
- Personal Navigation Device.
- Other devices which require high quality displays.

## 2.0 INPUT INTERFACE PIN ASSIGNMENT

FPC connector is used for electronics interface.

| PinNo. | Symbol | Function   |
|--------|--------|--|
| 1      | LEDK   | LED back light(Cathode)                                |
| 2      | LEDA   | LED back light(Anode)                                  |
| 3      | GND    | Ground   |
| 4      | VCC    | Power Supply. 2.8V                                     |
| 5-12   | R0-R7  | RGB Red data input                                     |
| 13-20  | G0-G7  | RGB green data input                                   |
| 21-28  | B0-B7  | RGB blue data input                                    |
| 29     | GND    | Ground   |
| 30     | CLK    | Dot clock signal for RGB interface operation           |
| 31     | DISP   | Display control / standby mode selection               |
| 32     | HSYNC  | Line synchronizing signal for RGB interface operation  |
| 33     | VSYNC  | Frame synchronizing signal for RGB interface operation |
| 34     | DE     | Data enable signal for RGB interface operation         |
| 35     | NC     | NC   |
| 36     | GND    | Ground   |
| 37     | XR     | Touch the right end line                               |
| 38     | YD     | Touch the lower line                                   |
| 39     | XL     | Touch the left line                                    |
| 40     | YU     | Touch the upper circuit                                |

### 3.0 ABSOLUTE MAXIMUM RATINGS

#### 3.1 Electrical Absolute Rating

##### 3.1.1 TFT LCD Module

| Item                     | Symbol | Min  | Max      | Unit | Note  |
|--------------------------|--------|------|----------|------|-------|
| Digital supply voltage   | VDDI   | -0.3 | +4.6     | V    | GND=0 |
| Analog supply voltage    | VCI    | -0.3 | +4.6     | V    | GND=0 |
| Logic Signal Input Level | VIN    | -0.3 | VDDI+0.5 | V    | GND=0 |

##### 3.1.2 Back-Light Unit

| Item        | Symbol          | Min  | Max  | Unit | Note |
|-------------|-----------------|------|------|------|------|
| LED current | I <sub>BL</sub> | -    | 20   | mA   | -    |
| LED voltage | V <sub>BL</sub> | 19.6 | 22.4 | V    | -    |

#### 3.2 Environment Absolute Rating

| Item                  | Symbol | Min | Max | Unit | Note |
|-----------------------|--------|-----|-----|------|------|
| Operating temperature | TOPR   | -20 | 70  | °C   | -    |
| Storage temperature   | TSTG   | -30 | 80  | °C   | -    |

Note:

Permanent damage may occur to the LCD module if beyond this specification.

## 4.0 OPTICAL CHARACTERISTICS

### 4.1 Optical specification

| Item                         |       | Symbol     | Condition   | Min   | Type  | Max   | Unit              | Note      |
|------------------------------|-------|------------|---|-------|-------|-------|-------------------|-----------|
| White luminance (Center)     |       | Lv         | $\Theta=0$<br>Normal Viewing Angle<br>$I_{BL}=80mA$ | --    | 300   | --    | cd/m <sup>2</sup> | (4)(5)(7) |
| Response time                |       | Tr+Tf      |   | --    | 25    | 50    | ms                | (3)       |
| Contrast ratio               |       | CR         |   | 300   | 500   | --    | --                | (2)(4)    |
| Color Chromaticity (CIE1931) | white | Wx         |   | 0.283 | 0.313 | 0.343 |                   | (6)       |
|                              |       | Wy         | 0.293   | 0.323 | 0.353 |       |                   |           |
| Viewing Angle                | Hor   | $\Theta_L$ | CR $\geq$ 10  | 60    | 70    | --    |                   | (1)       |
|                              |       | $\Theta_R$ |   | 60    | 70    | --    |                   |           |
|                              | Ver   | $\Theta_U$ |   | 50    | 60    | --    |                   |           |
|                              |       | $\Theta_D$ |   | 40    | 50    | --    |                   |           |
| Brightness uniformity        |       | Avg        | $\Theta=0$  | 80    | 90    | --    | %                 | (5)       |
| Color Gamut                  |       | NTSC       | $\Theta=0$  | --    | 52    | --    | %                 | (6)       |
| Optima View Direction        |       | 6 o'clock  |   |       |       |       |                   | (1)       |

### 4.2 Measuring Condition

- Measuring surrounding: dark room
- LED current IL:20mA
- Ambient temperature:  $25 \pm 2^\circ C$
- 15min. warm-up time

### 4.3 Measuring Equipment

- FPM520 of Westar Display technologies, INC., which utilized SR-3 for Chromaticity and BM-7 for other optical characteristics.
- Measuring spot size: 20 ~ 21 mm

|        |              |      |
|--------|--------------|------|
| Rev No | Issued Date. | Page |
| A      | 2021.11.01   | 6/18 |

### Note (1) Definition of Viewing Angle

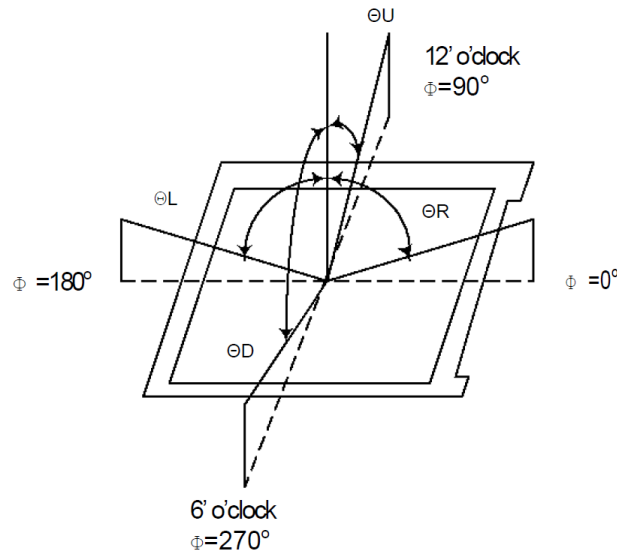

### Note (2) Definition of Contrast Ratio(CR):

Measured at the center point of panel

$$CR = \frac{\text{Luminance with all pixels white}}{\text{Luminance with all pixels black}}$$

### Note (3) Definition of Response Time: Sum of TR and TF

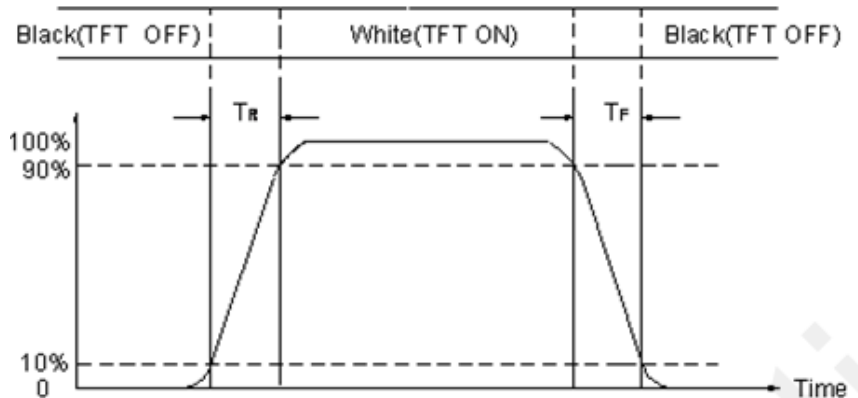

### Note (4) Definition of optical measurement setup

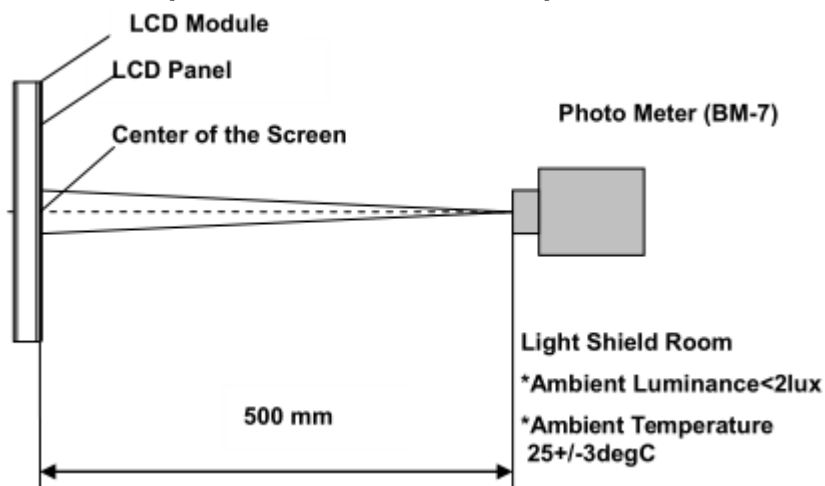

**Note (5) Definition of brightness uniformity**

The luminance uniformity is calculated by using following formula.

$$\Delta B_p = B_p (\text{Min.}) / B_p (\text{Max.}) \times 100 (\%)$$

$B_p (\text{Max.})$  = Maximum brightness in 9 measured spots

$B_p (\text{Min.})$  = Minimum brightness in 9 measured spots .

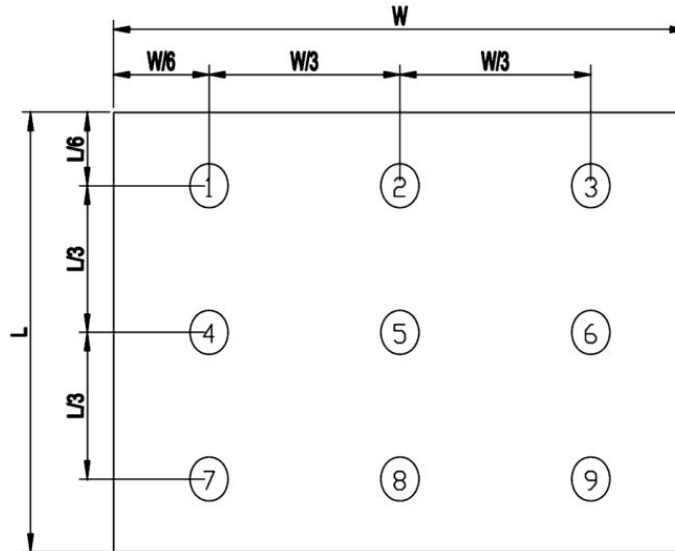

**Note (6) Definition of Color of CIE1931 Coordinate and NTSC Ratio.**

Color gamut:

$$S = \frac{\text{Area of RGB triangle}}{\text{Area of NTSC triangle}} \times 100\%$$

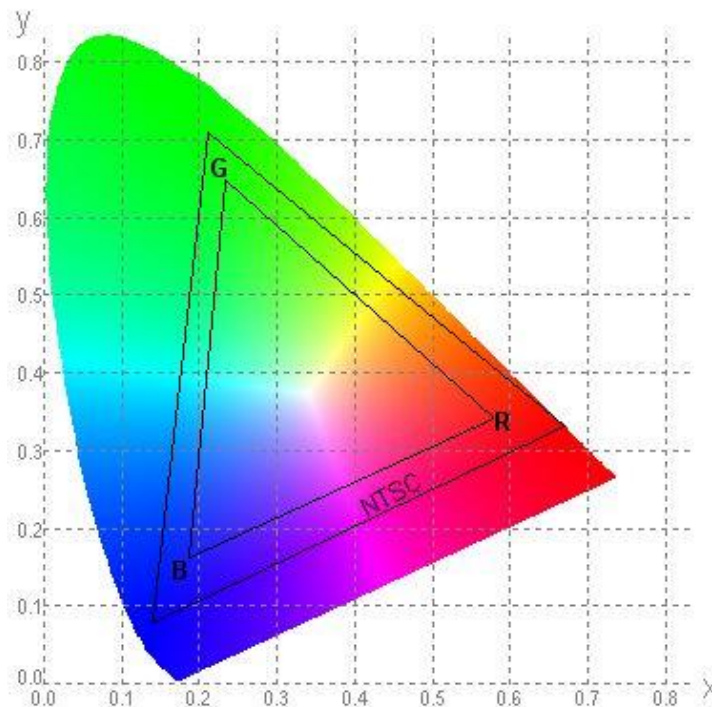

**Note (7) Measured the luminance of white state at center point.**

## 5.0 BLOCK DIAGRAM

### 5.1 TFT LCD Module

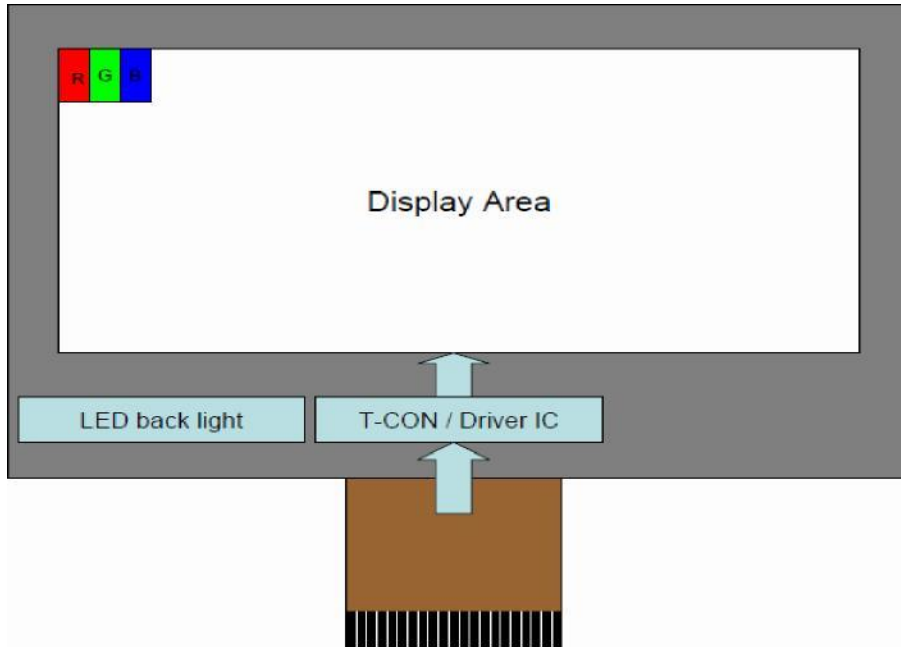

### 5.2 Pixel Format

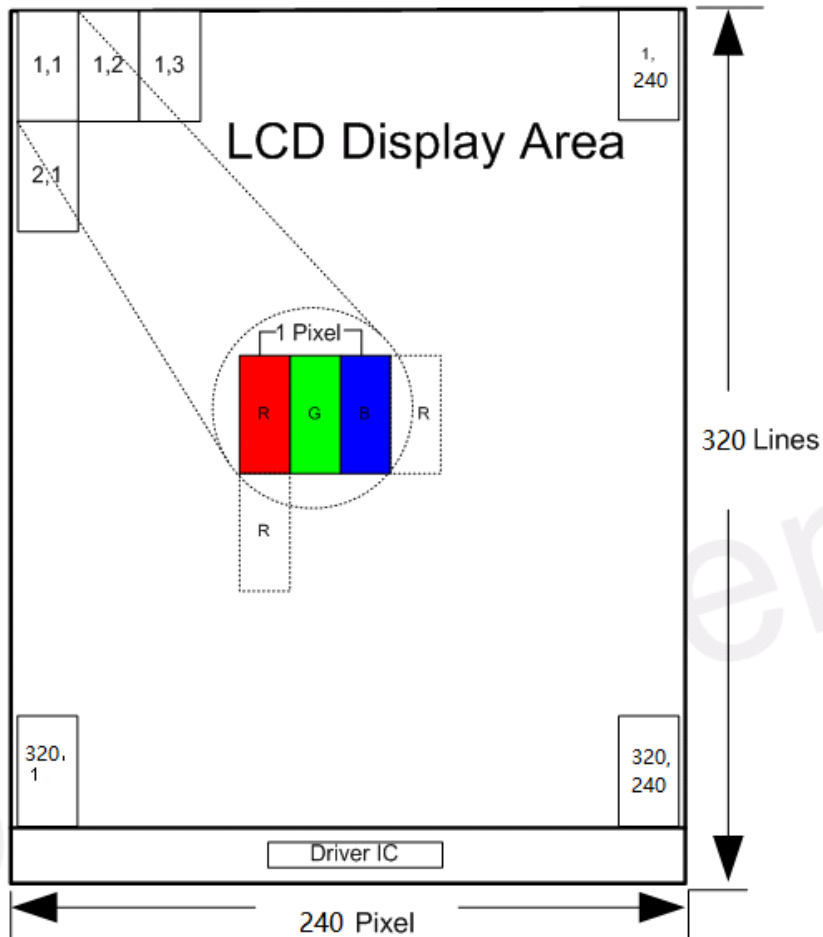



## 6.0 ELECTRICAL CHARACTERISTICS

### 6.1 TFT LCD Module

| Item                   | Symbol | Min.    | Typ. | Max.    | Unit | Remark |
|------------------------|--------|---------|------|---------|------|--------|
| Analog supply voltage  | VDD    | 2.4     | 2.8  | 3.3     | V    |        |
| Digital supply voltage | VDDI   | 1.65    | 1.8  | 3.3     |      |        |
| Input signal Voltage   | VIH    | 0.7VDDI | -    | VDDI    | V    |        |
|                        | VIL    | GND     | -    | 0.3VDDI | V    |        |

### 6.2 Back-Light Unit

The backlight system is an edge-lighting type with 7 LED Dies.

The characteristics of the LED are shown in the following tables.

| Item                    | Symbol | Min | Typ  | Max | Unit | Note   |
|-------------------------|--------|-----|------|-----|------|--------|
| LED current             | IL     | -   | 15   | 20  | mA   | (2)    |
| LED voltage             | VL     | -   | 19.6 | -   | V    |        |
| Operating LED life time | Hr     | -   | 5000 | -   | Hour | (1)(2) |

Note (1) LED life time (Hr) can be defined as the time in which it continues to operate under the condition:  $T_a=25\pm 3\text{ }^\circ\text{C}$ , typical IL value indicated in the above table until the brightness becomes less than 50%.

Note (2) The "LED life time" is defined as the module brightness decrease to 50% original brightness at  $T_a=25\text{ }^\circ\text{C}$  and  $I_L=80\text{mA}$ . The LED lifetime could be decreased if operating  $I_L$  is larger than 100mA. The constant current driving method is suggested.

Note (3) Suggested schematic of LED backlight driver

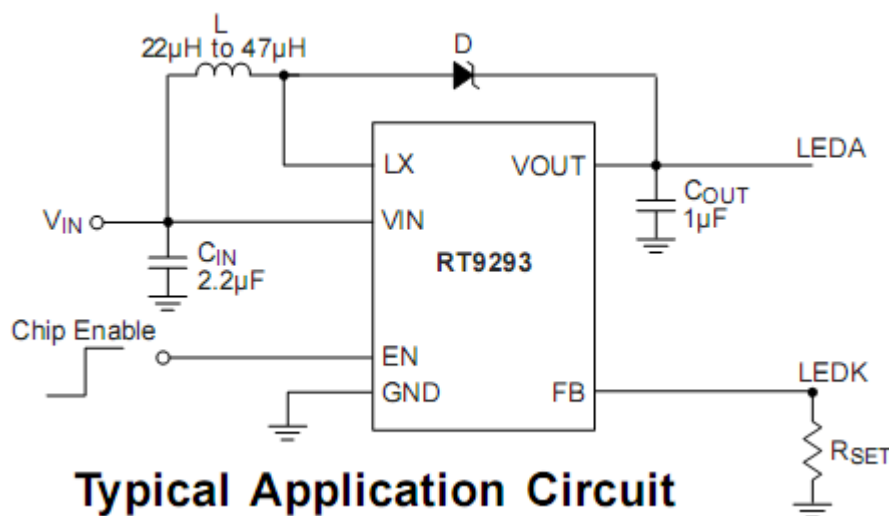

### 6.3 Interface Characteristics

8080 Series RGB Parallel Interface Characteristics: 24-bit Bus

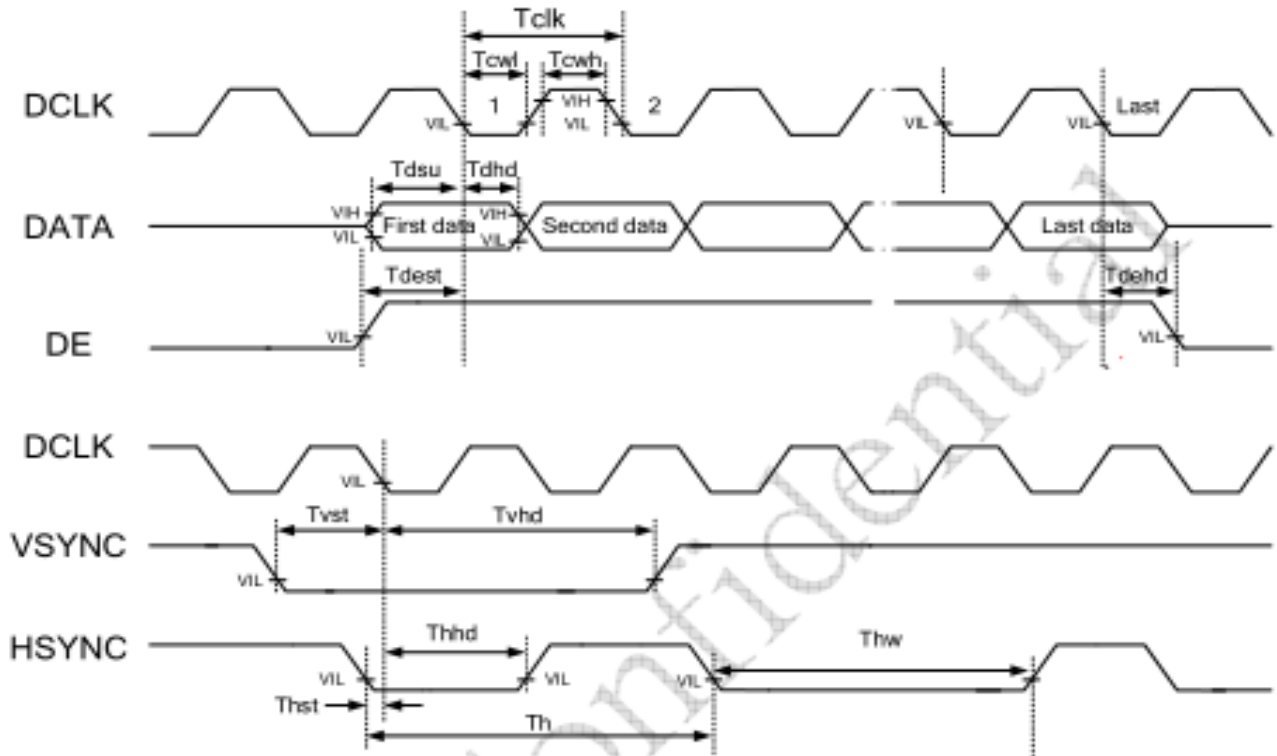

#### 10.1.1 Parallel 24-bit RGB Timing Table

| Item           | Symbol         | Min.   | Typ. | Max. | Unit | Remark |                       |
|----------------|----------------|--------|------|------|------|--------|-----------------------|
| DCLK Frequency | Fclk           | 8      | 9    | 12   | MHz  |        |                       |
| DCLK Period    | Tclk           | 83     | 111  | 125  | ns   |        |                       |
| HSYNC          | Period Time    | Th     | 485  | 531  | 598  | DCLK   |                       |
|                | Display Period | Thdisp | -    | 480  | -    | DCLK   |                       |
|                | Back Porch     | Thbp   | 3    | 43   | 43   | DCLK   | By H_Blanking setting |
|                | Front Porch    | Thfp   | 2    | 8    | 75   | DCLK   |                       |
|                | Pulse Width    | Thw    | 2    | 4    | 75   | DCLK   |                       |
| VSYNC          | Period Time    | Tv     | 276  | 292  | 321  | H      |                       |
|                | Display Period | Tvdisp | -    | 272  | -    | H      |                       |
|                | Back Porch     | Tvbp   | 2    | 12   | 12   | H      | By V_Blanking setting |
|                | Front Porch    | Tvfp   | 2    | 8    | 37   | H      |                       |
|                | Pulse Width    | Tvw    | 2    | 4    | 37   | H      |                       |

Note: It is necessary to keep Tvbp =12 and Thbp =43 in sync mode. DE mode is unnecessary to keep it.

## 7.0 Reliability conditions

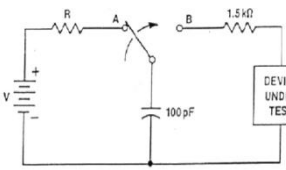
| NO        | Item   | Conditions   | Notes |               |         |         |          |            |           |              |  |
|-----------|--|--|-------|---------------|---------|---------|----------|------------|-----------|--------------|--|
| 1         | High Temperature Storage                     | Ta=80°C ± 2°C, 72hrs   |       |               |         |         |          |            |           |              |  |
| 2         | Low Temperature Storage                      | Ta=-30°C ± 2°C, 72hrs  |       |               |         |         |          |            |           |              |  |
| 3         | High Temperature Operation                   | Ta=70°C ± 2°C, 72hrs(Operation state)  |       |               |         |         |          |            |           |              |  |
| 4         | Low Temperature Operation                    | Ta=-20°C ± 2°C, 72hrs(Operation state)   |       |               |         |         |          |            |           |              |  |
| 5         | High Temperature and High Humidity (Storage) | Ta=+60°C, 90%RH, 72hrs   |       |               |         |         |          |            |           |              |  |
| 6         | Thermal Cycling Test (non operation)         | -20°C (30min) → +70°C (30min), 10cycles  |       |               |         |         |          |            |           |              |  |
| 7         | Electro static Discharge                     | Human Body Mode<br>100pF ± 10%/1500 Ω ± 1%<br>Air ± 8kV / contact ± 6kV<br>Consecutive 10times/ Each discharge<br> <table border="1" style="margin-left: auto; margin-right: auto;"> <thead> <tr> <th>CLASS</th> <th>STRESS LEVELS</th> </tr> </thead> <tbody> <tr> <td>CLASS I</td> <td>0-1999V</td> </tr> <tr> <td>CLASS II</td> <td>2000-3999V</td> </tr> <tr> <td>CLASS III</td> <td>4000-15999 V</td> </tr> </tbody> </table> | CLASS | STRESS LEVELS | CLASS I | 0-1999V | CLASS II | 2000-3999V | CLASS III | 4000-15999 V |  |
| CLASS     | STRESS LEVELS                                |  |       |               |         |         |          |            |           |              |  |
| CLASS I   | 0-1999V                                      |  |       |               |         |         |          |            |           |              |  |
| CLASS II  | 2000-3999V                                   |  |       |               |         |         |          |            |           |              |  |
| CLASS III | 4000-15999 V                                 |  |       |               |         |         |          |            |           |              |  |
| 8         | Vibration test(with carton)                  | Total fixed<br>amplitude:15mm<br>Vibration Frequency :10~55Hz<br>One cycle 60 seconds to 3 directions of<br>X,Y,Z for Each 15 minutes  |       |               |         |         |          |            |           |              |  |
| 9         | Drop (with carton)                           | Height: 60cm<br>1 corner, 3 edges, 6 surfaces  |       |               |         |         |          |            |           |              |  |

**Note: There is no display function NG issue occurred, all the cosmetic specification is judged before the reliability stress.**

## 8.0 Precautions





### 8.1 Operation

Burn-in sometimes happens when the same character was displayed at along time. Therefore, to prevent Burn-in, it is recommended to set up a Screen-saver function.

### 8.2 Safety

The liquid crystal in the LCD is poisonous, DO NOT put it in your mouth. If the liquid crystal touches your skin or clothes, wash it off immediately using soap and water.

### 8.3 Handling

|   |  |
|---|--|
|    | <p>a. The LCD module shall be installed flat, without twisting or bending.</p> <p>b. COF or FPC has narrow pattern width, so easily become open circuit by external force. DO NOT apply pressure to COF or FPC especially in bending area.</p> |
|  | <p>c. To avoid damage in appearance or malfunction, DO NOT subject the module to mechanical shock or to excessive force on its surface.</p>  |
|  | <p>d. The polarizer attached to the display is very easy to damage, handle it with care to avoid scratching.</p>   |
|  | <p>e. To avoid contamination on the display surface, DO NOT touch the display surface with bare hands.</p> <p>f. Provide a space so that the LCD module does not come into contact with other components.</p>                                  |

### 8.4 Static Electricity

Since a module is composed of electronic circuits, it is not strong to electrostatic discharge.



- a. The LCD module shall be installed flat, without twisting or bending. Ground soldering iron tips, tools and testers when they operate.
- b. Ground your body when handling the products.
- c. DO NOT apply voltage to the input terminal without applying power supply.
- d. DO NOT apply voltage that exceeds the absolute maximum rating.
- e. Store the products in an anti-electrostatic container.
- f. Peel off protect tape, attached to polarizer, slowly to minimize ESD damage.

### 8.5 Storage



Store the products in a dark place at +5 ~ +25 degree C, low humidity (50%RH or less).  
DO NOT store the products in an atmosphere containing organic solvents or corrosive gases.

### 8.6 Cleaning



- a. DO NOT wipe the polarizer with dry cloth, as it might cause scratch.
- b. Wipe the polarizer with a soft cloth soaked with petroleum IPA, other chemical might damage.

### 8.7 Waste



When dispose of LCD module, manage it at the production waste according to the relevant laws and regulations.

## 9.0 OUTINE DIMENSION

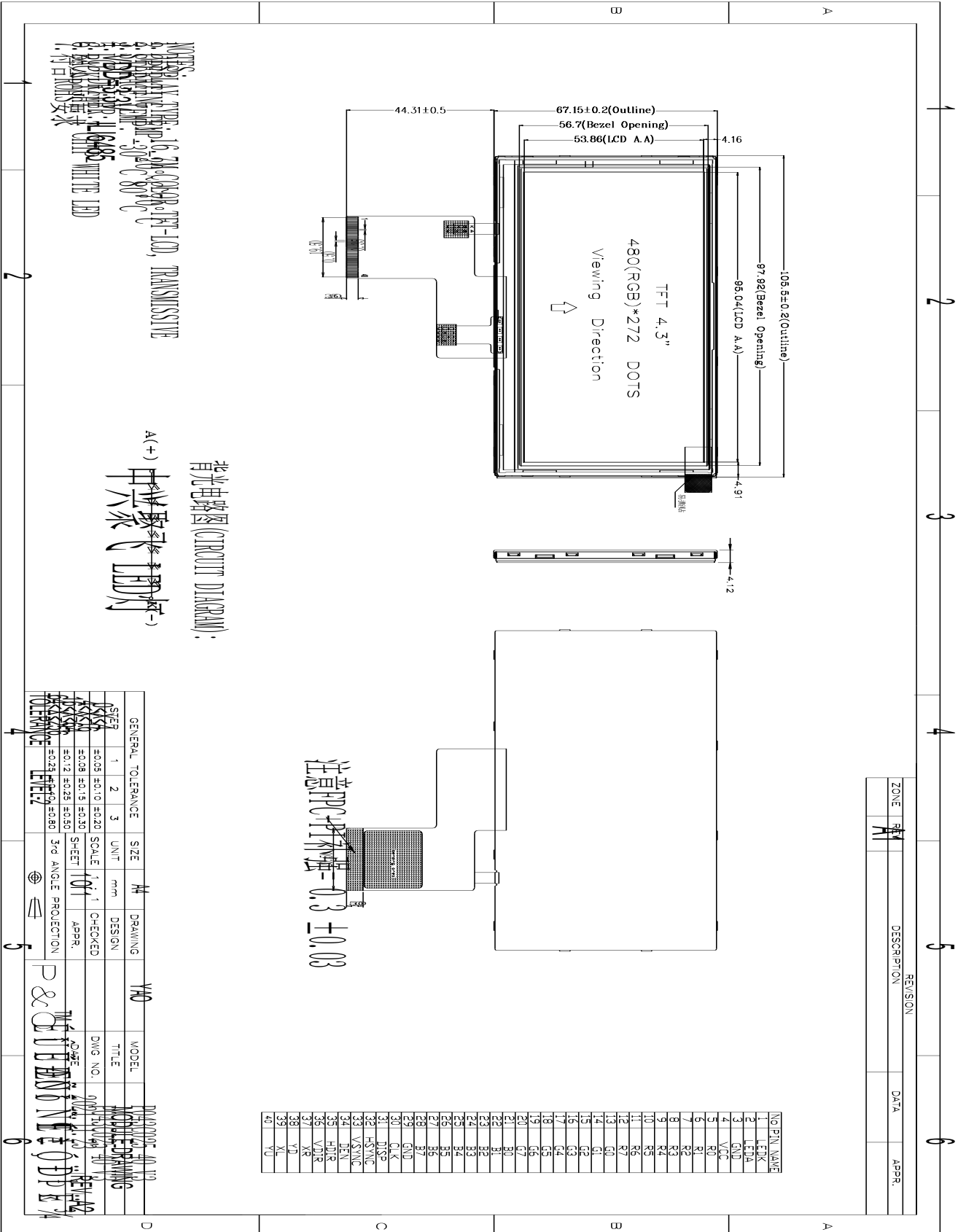

## 1 0.0 LOT MARK

### 10.1 Location of Lot Mark

- (1) Location: The label is attached to the backside of the LCD module.
- (2) Detail of the Mark: as attached below.
- (3) This is subject to change without prior notice.

## 11.0 PACKAGE SPECIFICATION

### 11.1 Packing form

| LCM Model | LCM Qty. in the box | Inner Box Size ( mm ) | Notice |
|-----------|---------------------|-----------------------|--------|
|           | TDB                 | TDB                   |        |

### 11.2 Packing assembly drawings

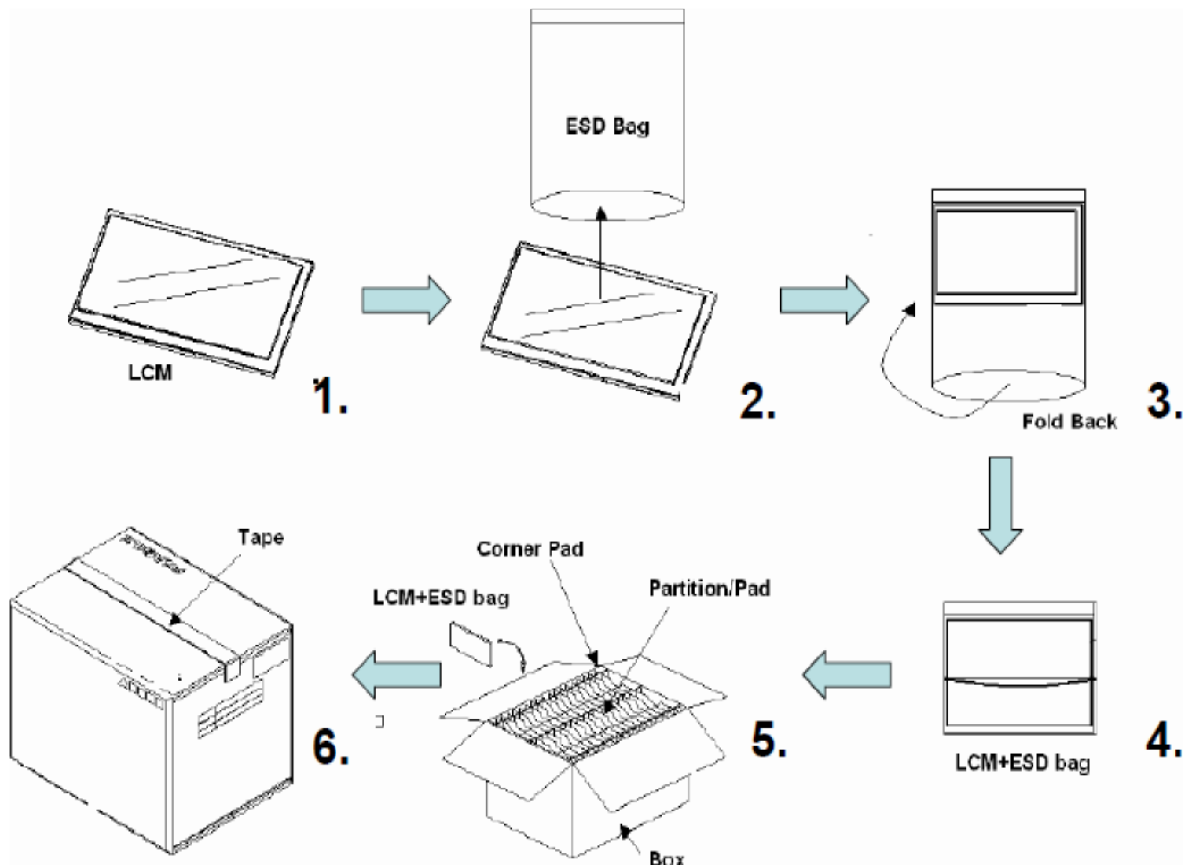

| Items         | Material               | Notice    |
|---------------|------------------------|-----------|
| Box           | Corrugated Paper Board | AB Flute  |
| Partition/Pad | Corrugated Paper Board | A/B Flute |
| Corner Pad    | Corrugated Paper Board | AB Flute  |
| ESD bag       | PE                     |           |

## 12.0 Items and Criteria:

### 12.1 Guarantee

APEX warrants the quality of our products for **1 year** (from the date of delivery). If there are functional defects found during the period of warranty, the defective products would be replaced on a one-to-one basis.

Apex would not be responsible for any direct /indirect liabilities consequential to any parties.

All the products should be stored or used as specified conditions described in these sheets. If module productions are not stored or used as specified conditions, herein, it will be void the **1 year** warranty(guarantee).

### 12.2 Visual inspection criterion in cosmetic

#### (1) Glass defect

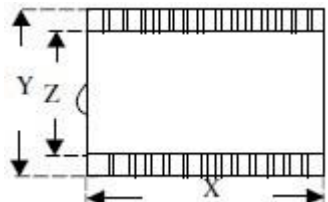
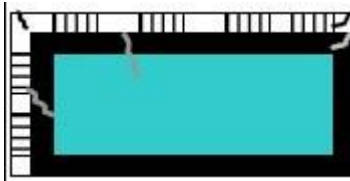
| Glass defect |                  |                                 |  |
|--------------|------------------|---------------------------------|--|
| NO           | Defect           | Criteria                        | Remark   |
| 1            | Dimension(Minor) | By engineering diagram          |    |
| 2            | Cracks(Major)    | Extensive crack <b>【Reject】</b> |  |

#### (2) LCM appearance defect

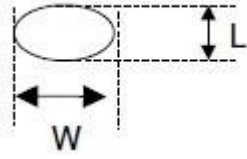
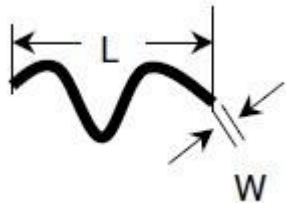
| NO | Defect                | Criteria   |                 | Remark  |
|----|-----------------------|--|-----------------|---|
| 1  | Round type(Minor)     | Spec   | Permissible Qty | 1. $\psi = (L+W)/2$ , L: Length, W: Width<br>2. Disregard if out of A.A.<br> |
|    |                       | $\psi \leq 0.10\text{mm}$  | Disregard       |   |
|    |                       | $0.10\text{mm} < \psi \leq 0.20\text{mm}$                        | 3               |   |
|    |                       | $0.20\text{mm} < \psi$   | 0               |   |
| 2  | Line type(Minor)      | Spec   | Permissible Qty | 1. L: Length, W: Width<br>2. Disregard if out of A.A.<br>                    |
|    |                       | $W \leq 0.03\text{mm}$   | Disregard       |   |
|    |                       | $L \leq 3.0\text{mm}$ and $0.03\text{mm} < W \leq 0.05\text{mm}$ | 2               |   |
|    |                       | $L \leq 3.0\text{mm}$ and $0.05\text{mm} < W \leq 0.10\text{mm}$ | 1               |   |
|    |                       | $W > 0.10\text{mm}$ or $L > 3.0\text{mm}$                        | 0               |   |
| 3  | Polarizer dent(Minor) | Spec.  | Permissible Qty | 1. $\psi = (L+W)/2$ , L: Length, W: Width<br>2. Disregard if out of A.A.  |
|    |                       | $\psi \leq 0.20\text{mm}$  | Disregard       |   |
|    |                       | $0.20\text{mm} < \psi \leq 0.30\text{mm}$                        | 2               |   |
|    |                       | $0.30\text{mm} < \psi \leq 0.50\text{mm}$                        | 1               |   |



|   |        |              |       |
|---|--------|--------------|-------|
| <b>Shenzhen P&amp;O Technology Co., Limited</b> | Rev No | Issued Date. | Page  |
|   | A      | 2021.11.01   | 17/18 |

(3) FPC

| NO | Defect                 | Criteria   | Remark |
|----|------------------------|--|--------|
| 1  | Copper peeling(Minor)  | Copper peeling <b>【Reject】</b>   |        |
| 2  | Golden finger          | FPC golden finger broken, dead fold, indentation makes FPC surface broken <b>【Reject】</b><br>Tin plating layer(or gold plating) scratch, but not hurt circuit <b>【Accept】</b><br>Except circuit, other position scratch but not expose metal wire <b>【Accept】</b>  |        |
| 3  | Pin                    | FPC PI layer delamination <b>【Reject】</b><br>Material and color are inconsistent with sample, FPC burrs <b>【Reject】</b><br>FPC Pin deformation but not affect function. <b>【Accept】</b><br>FPC Pin area is dirty <b>【Reject】</b><br>Other than FPC Pin area is dirty but not affect function <b>【Accept】</b>   |        |
| 4  | Golden finger          | Golden finger edge has burrs,foreign material <b>【Reject】</b><br>Golden finger oxidation (dark), uneven electroplating, pinhole, foreign material <b>【Reject】</b><br>Golden finger soldering pad crack exceeds 1/3 length of soldering pad, and soldering pad crack exceed 2 Pins <b>【Reject】</b><br>Golden finger tin plating(or gold plating)scratch, but not hurt circuit <b>【Accept】</b><br>Other than golden finger area scratch but not expose metal circuit <b>【Accept】</b> |        |
| 5  | FPC Silk printing      | Ghosting, incomplete silk printing, wrong printing <b>【Reject】</b>   |        |
| 6  | FPC Circuit line width | Line width deviation exceed 1/3 line width <b>【Reject】</b>   |        |



(4) Black tape

| NO | Defect               | Criteria                      | Remark |
|----|----------------------|-------------------------------|--------|
| 1  | Shift(Minor)         | IC exposed <b>【Reject】</b>    |        |
| 2  | No black tape(Minor) | No black tape <b>【Reject】</b> |        |

(5) Silicon

| NO | Defect                    | Criteria                    | Remark |
|----|---------------------------|-----------------------------|--------|
| 1  | Amount of silicon (Minor) | ITO exposed <b>【Reject】</b> |        |

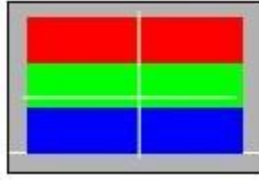
### 12.3 Visual inspection criterion in electrical display

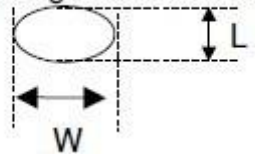
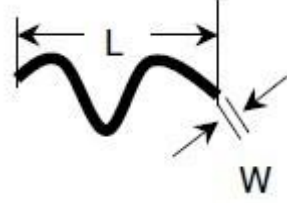
| NO | Defect                         | Criteria   |                 | Remark  |
|----|--------------------------------|--|-----------------|---|
| 1  | No display (Major)             | Not allowed  |                 |    |
| 2  | Missing line (Major)           | Not allowed  |                 |    |
| 3  | Darker or lighter Line (Major) | Not allowed  |                 |    |
| 4  | Weak line(Major)               | By limited sample  |                 |   |
| 5  | Bright / Dark point (Minor)    | Spec.  | Permissible Qty | 1:1sub-pixel: 1R or 1G or1B<br>2:Point defect area $\geq$ 1/2 sub pixel.  |
|    |                                | Bright point   | 1               |   |
|    |                                | Dark point   | 2               |   |
| 6  | Round type (Minor)             | Spec   | Permissible Qty | 1. $\psi=(L+W)/2$ , L: Length, W: Width<br>2. Disregard if out of A.A.<br> |
|    |                                | $\psi \leq 0.10\text{mm}$  | Disregard       |   |
|    |                                | $0.10\text{mm} < \psi \leq 0.20\text{mm}$                        | 3               |   |
|    |                                | $0.20\text{mm} < \psi$   | 0               |   |
| 7  | Line type (Minor)              | Spec.  | Permissible Qty | 1. L: Length, W: Width<br>2. Disregard if out of A.A.<br>                  |
|    |                                | $W \leq 0.03\text{mm}$   | Disregard       |   |
|    |                                | $L \leq 3.0\text{mm}$ and $0.03\text{mm} < W \leq 0.05\text{mm}$ | 2               |   |
|    |                                | $L \leq 3.0\text{mm}$ and $0.05\text{mm} < W \leq 0.10\text{mm}$ | 1               |   |
|    |                                | $W > 0.10\text{mm}$ or $L > 3.0\text{mm}$                        | 0               |   |
| 8  | Mura (Minor)                   | By 5% ND filter invisible  |                 |   |

### 9.2.4. Others

- Issues that are not defined in this document shall be discussed and agreed with both parties.  
(Customer and supplier)
- Unless otherwise agreed upon in writing, the criteria shall be applied to both parties.  
(Customer and supplier)