

深圳市炬烜科技有限公司

CHIP SUN TECHNOLOGY CO., LTD

APPROVAL SHEET



CUSTOMER: _____

DESCRIPTION: SMD3.2*1.5 32.768KHz Quartz Crystal Resonator

MANUFACTURER PART NO.: FTX32.768K9SM3S-20DEW

CUSTOMER PART NO: _____

USED IN MODEL: _____

REVISION A1

承 认 APPROVAL		
工程部 TECHNOLOGY DEPT.	品质部 QUALITY DEPT.	采购部 PURCHASING DEPT.

Date: March 28, 2022



深圳市炬烜科技有限公司

CHIP SUN TECHNOLOGY CO., LTD

地址 ADD: 深圳市龙华新区大浪腾龙路淘金地电子商务孵化基地 B 座 206

Rm. Rm 206, Tower B, Taojindi Building, Tenglong Road, Dalang Street, Longhua New District, Shenzhen, China

电话 TEL: 86-755-83458769 传真 FAX: 86-755-83459818

网址 WEB ADD: <http://www.chinachipsun.com>

E-MAIL: sales01@chinachipsun.com

<u>Rev</u>	<u>Revise page</u>	<u>Revise contents</u>	<u>Date</u>	<u>Ref.No.</u>	<u>Reviser</u>
A1	ALL	Initial released	2022.3.28	N/A	DavidJiang

CHIP SUN TECHNOLOGY CO., LTD		
DESCRIPTION	SMD3.2×1.5 32.768KHz ±20ppm 9pF	Page:
DATE	2022-03-28	2 / 9

1. QUARTZ CRYSTAL UNIT SPECIFICATION

Parameter	Specification
1.1 Frequency:	32.768KHz
1.2 Holder type :	SMD3.2×1.5×0.8 mm
1.3 Frequency tolerance:	±20ppm at 25°C
1.4 Equivalent resistance:	70Kohms Max
1.5 Operating temperature range:	-40°C To +85°C
1.6 Storage temperature range:	-55°C To +125°C
1.7 Temperature Coefficient	-0.03×10 ⁻⁶ / °C ² Typical
1.8 Turn-over temperature::	+25°C±5°C
1.9 Loading capacitance (CL) :	9pF
1.10 Drive level:	0.5uW max
1.11 Shunt Capacitance:	1.0pF Typical
1.12 Motional Capacitance:	3.4fF Typical
1.13 Insulation resistance :	More than 500M ohms
1.14 Aging:	±3 ppm/Year Max Ta=+25°C±3°C, first year
1.15 Dimensions and marking	Refer to page.3
1.16 Emboss carrier tape & reel	Refer to page.5 and page.6
1.17 Note	

CHIP SUN TECHNOLOGY CO., LTD

DESCRIPTION	SMD3.2×1.5 32.768KHz ±20ppm 9pF	Page:
DATE	2022-03-28	3 / 9

2. DIMENSIONS (Unit: mm)

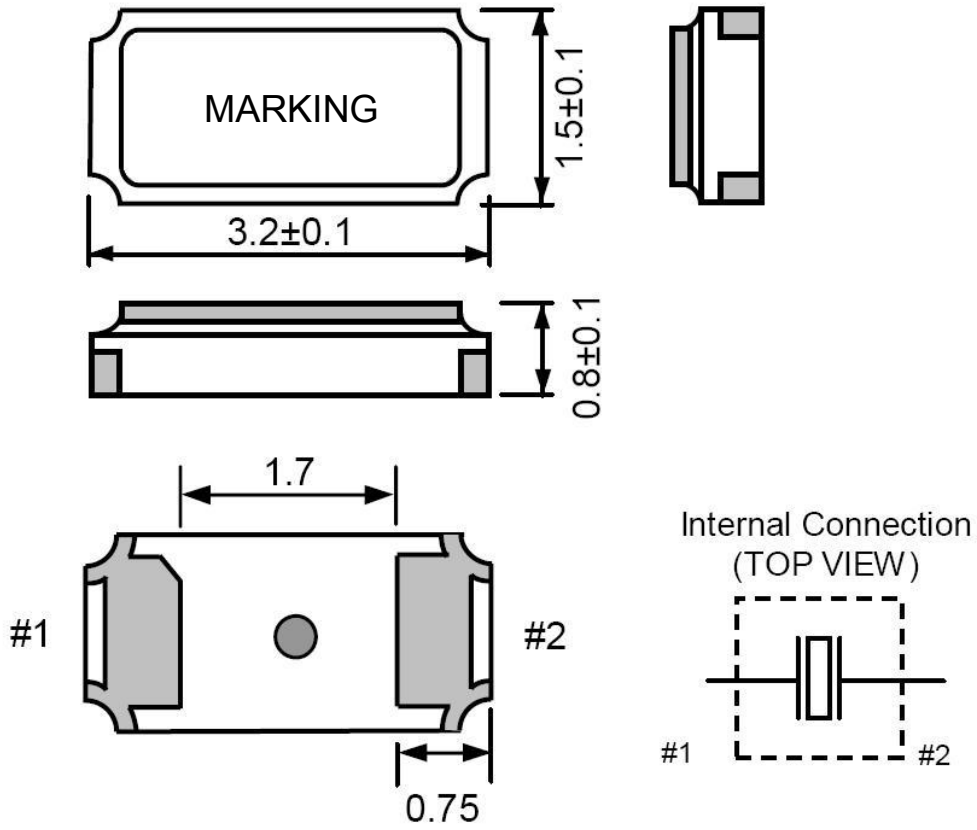

CHIP SUN TECHNOLOGY CO., LTD

DESCRIPTION	SMD3.2×1.5 32.768KHz ±20ppm 9pF	Page:
DATE	2022-03-28	4 / 9

3 CARRIER TAPE & REEL

a.) Dimensions of Carrier Tape

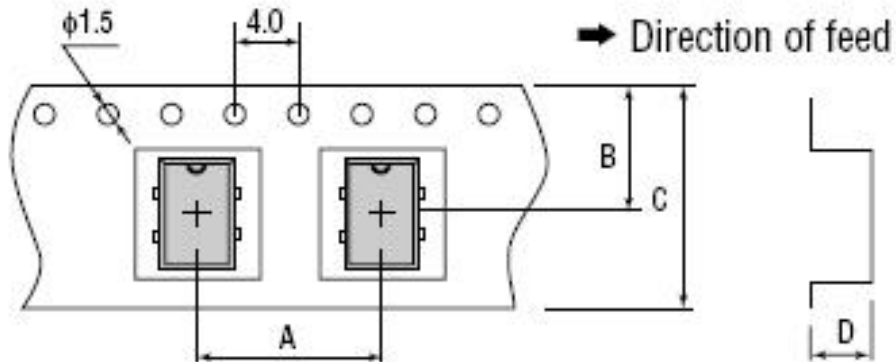

Dimension (Unit: mm)			
A	B	C	D
4.0	7.25	12.0	1.0

b.) Dimensions of Reel

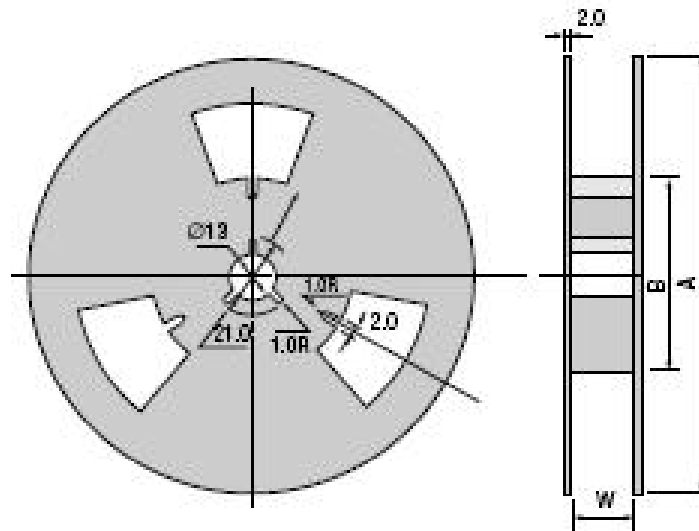

Dimension (Unit: mm)		
A	B	W
$\phi 180$	$\phi 60$	13.0

CHIP SUN TECHNOLOGY CO., LTD

DESCRIPTION	SMD3.2×1.5 32.768KHz ± 20 ppm 9pF	Page:
DATE	2022-03-28	5 / 9

a.) Storage condition

Temperature: -55deg.C To +125deg.C

Relative Humidity: 80% Max.

b.) Standard packing quantity

3,000PCS / REEL

c.) Material of the tape

Tape	Material
Carrier tape	A- PET
Top tape	Polyester

d.) Label contents

.The type of product

.Our specification No.

.Your Part No.

.Lot No.

.Nominal Frequency

.Quantity

.Our Company Name

Sticks label for every reel.

CHIP SUN TECHNOLOGY CO., LTD

DESCRIPTION	SMD3.2×1.5 32.768KHz ±20ppm 9pF	Page:
DATE	2022-03-28	6 / 9

e.) Taping dimension

Leader	Cover-tape	The length of cover-tape in the leader is more than 400 mm including empty embossed area.
	Carrier-tape	After all products were packaged, must remain more than twenty pieces or 400 mm empty area, which should be sealed by cover-tape.
Terminal	Cover-tape	The tip of cover-tape shall be fixed temporary by paper tape and roll around the core of reel one round.
	Carrier-tape	The empty embossed area which are sealed by top cover-tape must remain more the 40 mm.

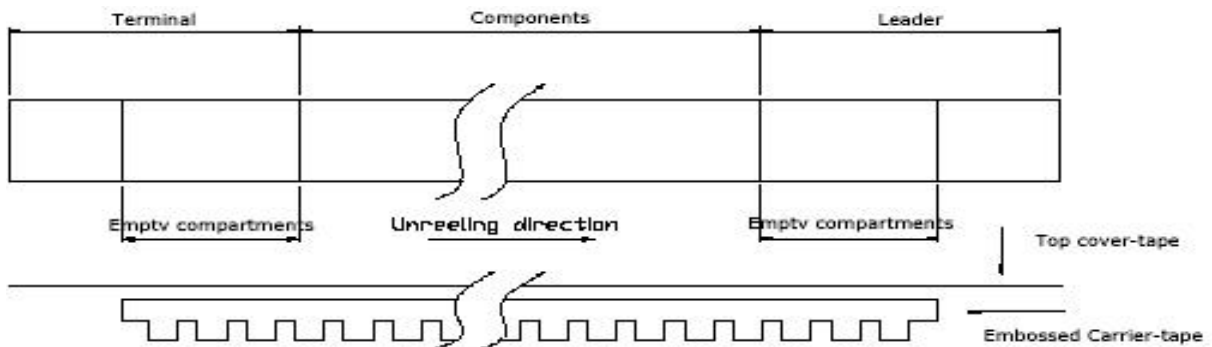

f.) Joint of tape

The carrier-tape and top cover-tape should not be jointed.

g.) Release strength of cover tape

It has to between 0.1N to 0.7N under following condition.

Pulling direction 165° to 180°

Speed 300mm/min.

Otherwise unless specified.

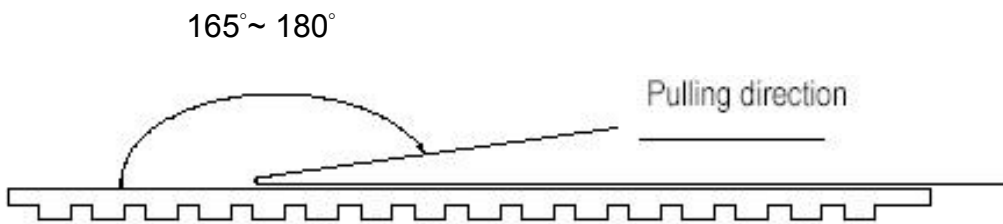

Other standards shall be based on JIS C 0806-1990.

CHIP SUN TECHNOLOGY CO., LTD		
DESCRIPTION	SMD3.2×1.5 32.768KHz ±20ppm 9pF	Page:
DATE	2022-03-28	7 / 9

4. Mechanical Endurance: Provided that measurement shall be carried out after letting it alone in the room temperature for 1 hour.

	Test Item	Condition of Test	Performance Requirements
4.1	Shock (Destructive)	Resonator shall be tested after 3 times random drops from the height of 75 cm onto hard wooden board of thickness more than 30 mm.	No visible damage, measured Values shall meet Table 1.
4.2	Vibration (Destructive)	Subject resonator to following vibration Frequency: 10-55Hz Amplitude: 0.75mm Cycle time: 1~2min(10-55-10Hz) Duration: 3 mutually perpendicular Planes in each 2 hours Direction: X, Y, Z	No visible damage, measured Values shall meet Table 1.
4.3	Terminal Strength (Destructive)	Pulling: body of resonator shall be fixed, and 0.5kg of tension weight shall be supplied gradually to axial direction of lead terminals for 30 seconds	The lead shall not be broken, measured Values shall meet Table 1.
		Bending: body of resonator shall be fixed, And 90 °C bending at a distance of 2.5±0.5 mm from crystal main body shall be given being supplied 250g tension weight. after that, lead terminals shall be straightened gradually. Then, the same bending and straightening shall be supplied to the opposite direction in the same axial.	
4.4	Solder Heating (Destructive)	Each lead terminals shall be dipped into the solder melted tank at 350±10 °C for 3±0.5 resonator, and at 260±10 °C for 10 ± 1 seconds by the same way.	No visible damage, measured Values shall meet Table 1.
4.5	Solder DIP. (Destructive)	Dip the lead in liquid solder for 2± 0.5 seconds, at 230±5 °C and 6.0mm from the root, after this dipping, 90% min. of dipped parts shall be covered with solder.	No visible damage, measured Values shall meet Table 1.
4.6	Leakage (non-destructive)	The resonator is to be soaked in the alcohol and enforced with the pressure of 25N/cm ² for 5 minutes Next, the resonator shall be tested after being taken out and dried with a dryer.	The Ir between the wire and the shell must be more than 500MΩ.

CHIP SUN TECHNOLOGY CO., LTD

DESCRIPTION	SMD3.2×1.5 32.768KHz ±20ppm 9pF	Page:
DATE	2022-03-28	8 / 9

5. Environmental Endurance: Provided that measurement shall be carried out after letting it alone in the room temperature for 1 hour.

	Item	Conditions	Specifications
5.1	Humidity	Should be satisfied after letting it alone at $+60^{\circ}\text{C}\pm 2^{\circ}\text{C}$ in humidity of $85\% \pm 5\%$ for 240 hours.	No visible damage, measured Values shall meet Table1.
5.2	Storage in Low Temperature	Should be satisfied after letting it alone at $-30^{\circ}\text{C}\pm 2^{\circ}\text{C}$ for 240 hours.	No visible damage, measured Values shall meet Table1
5.3	Storage in High Temperature	Should be satisfied after letting it alone at $+85^{\circ}\text{C}\pm 2^{\circ}\text{C}$ for 240 hours.	No visible damage, measured Values shall meet Table1
5.4	Temperature Cycle	Should be satisfied after supplying the following temperature cycle (10 cycles). (Refer to Fig-4). Temperature shift from low to high, high to low shall be done in $1^{\circ}\text{C} / \text{min}$.	No visible damage, measured Values shall meet Table1

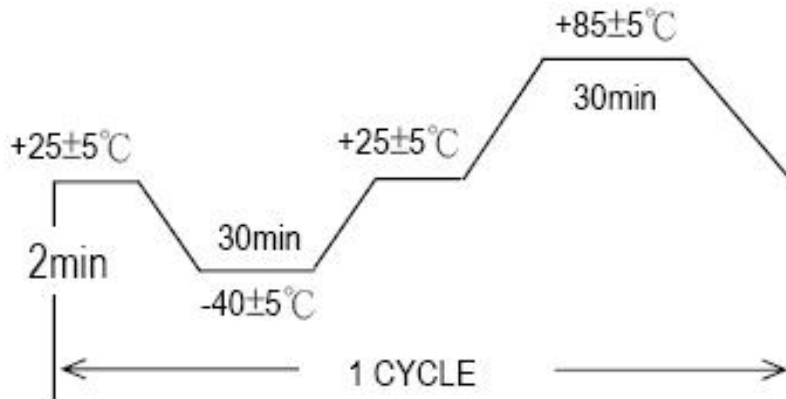

Fig-4

Table 1

Test Item	Specification	Note
Frequency change ($\Delta f/f_0$)	$\pm 5\text{ppm}$	Reference to the initial value
C.I. (ΔR)	15%	Reference to the initial value

CHIP SUN TECHNOLOGY CO., LTD		
DESCRIPTION	SMD3.2×1.5 32.768KHz $\pm 20\text{ppm}$ 9pF	Page:
DATE	2022-03-28	9 / 9