



SMBG Plastic-Encapsulate Diodes

SK22 THRU SK220 Schottky Rectifier Diodes

Features

- $I_{F(AV)}$ 2A
- V_{RRM} 20V-200V
- High surge current capability
- Polarity: Color band denotes cathode

Applications

- Rectifier

Marking

- SK2X
X : From 2 To 20

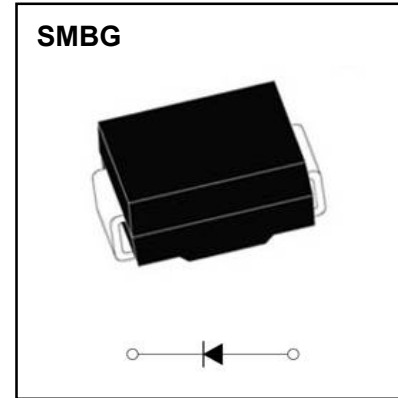

Limiting Values(Absolute Maximum Rating)

Item	Symbol	Unit	Test Conditions	SK 2														
				2	3	4	5	6	8	10	15	20						
Repetitive Peak Reverse Voltage	V_{RRM}	V		20	30	40	50	60	80	100	150	200						
Maximum RMS Voltage	V_{RMS}	V		14	21	28	35	42	56	70	105	140						
Average Forward Current	$I_{F(AV)}$	A	60Hz Half-sine wave, Resistance load	2.0														
Surge(Non-repetitive)Forward Current	I_{FSM}	A	60Hz Half-sine wave, 1 cycle, $T_a=25^\circ\text{C}$	50														
Junction Temperature	T_J	$^\circ\text{C}$		-55~+125					-55~+150									
Storage Temperature	T_{STG}	$^\circ\text{C}$		-55 ~ +150														

Electrical Characteristics ($T = 25^\circ\text{C}$ Unless otherwise specified)

Item	Symbol	Unit	Test Condition	SK 2														
				2	3	4	5	6	8	10	15	20						
Peak Forward Voltage	V_F	V	$I_F=2.0\text{A}$	0.55		0.70		0.85		0.95								
Peak Reverse Current	I_{RRM1}	mA	$V_{RM}=V_{RRM}$	$T_a=25^\circ\text{C}$		0.5		0.1										
	I_{RRM2}			$T_a=100^\circ\text{C}$		10		5.0										
Thermal Resistance	$R_{\theta J-A}$	$^\circ\text{C}/\text{W}$	Between junction and ambient	72														
	$R_{\theta J-L}$		Between junction and terminal	18														
Junction Capacitance (Typical)	C_j	pF	Measured at 1MHZ and Applied Reverse Voltage of 4.0 V.D.C	114		92		53		40								

Notes:

Thermal resistance from junction to ambient and from junction to lead mounted on FR4 PCB double sided copper mini pad

Typical Characteristics

FIG.1: FORWARD CURRENT DERATING CURVE

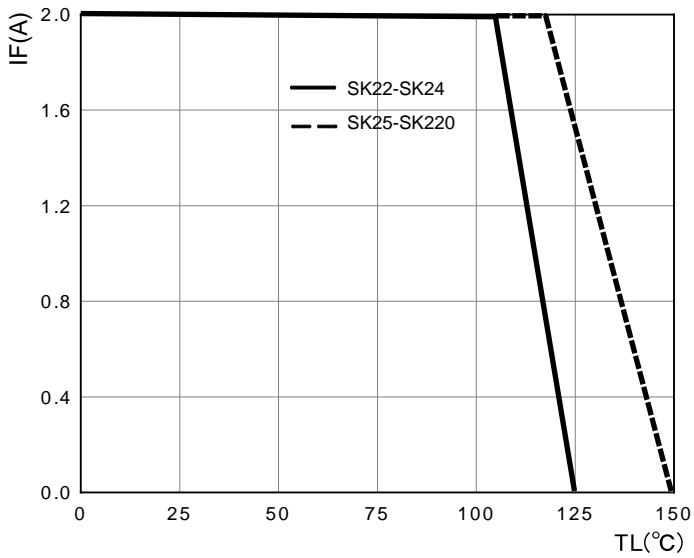
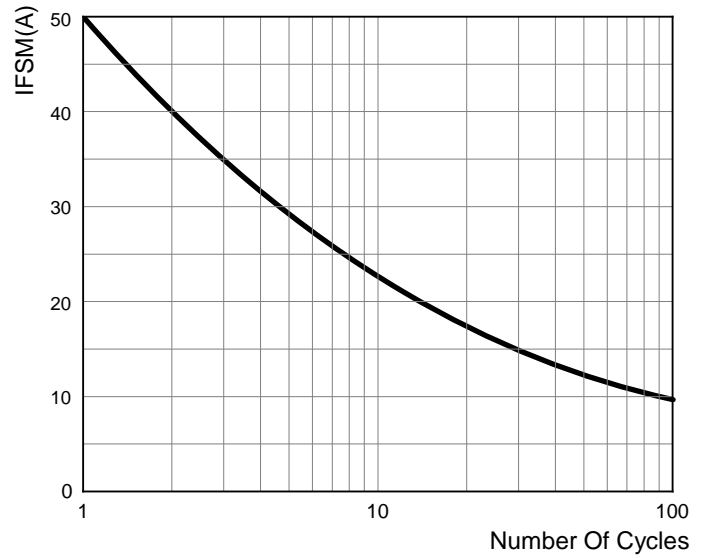
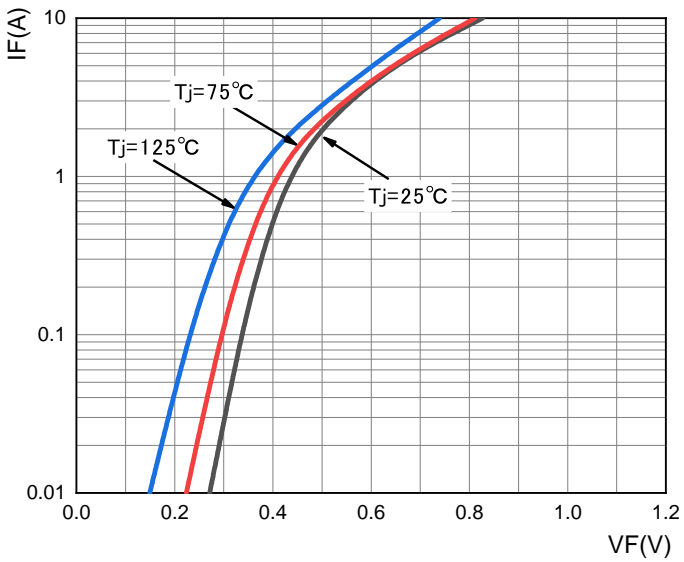

FIG.2: MAXIMUM NON-REPETITIVE FORWARD SURGE CURRENT



SK22-SK24

FIG.3: TYPICAL FORWARD CHARACTERISTICS



SK22-SK24

FIG.4: TYPICAL REVERSE CHARACTERISTICS

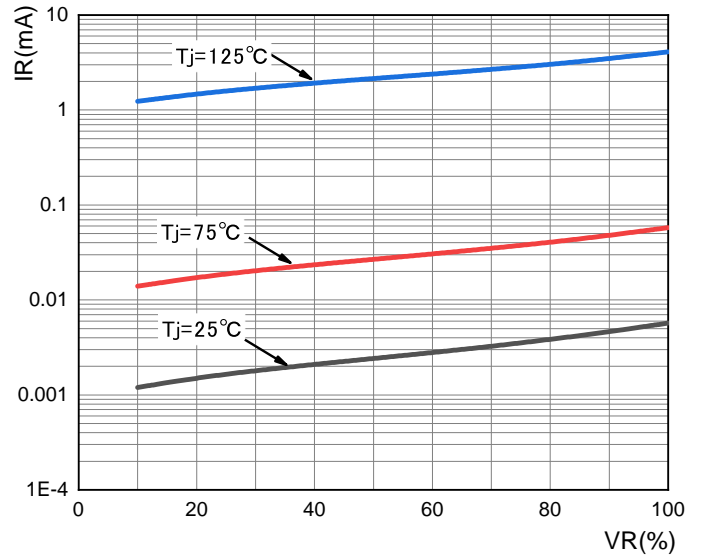

Typical Characteristics

SK25-SK26

FIG.5: TYPICAL FORWARD CHARACTERISTICS

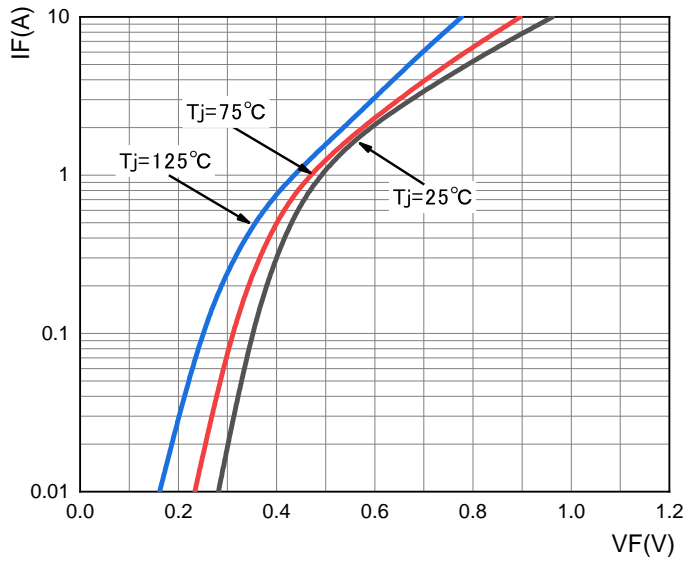

SK25-SK26

FIG.6: TYPICAL REVERSE CHARACTERISTICS

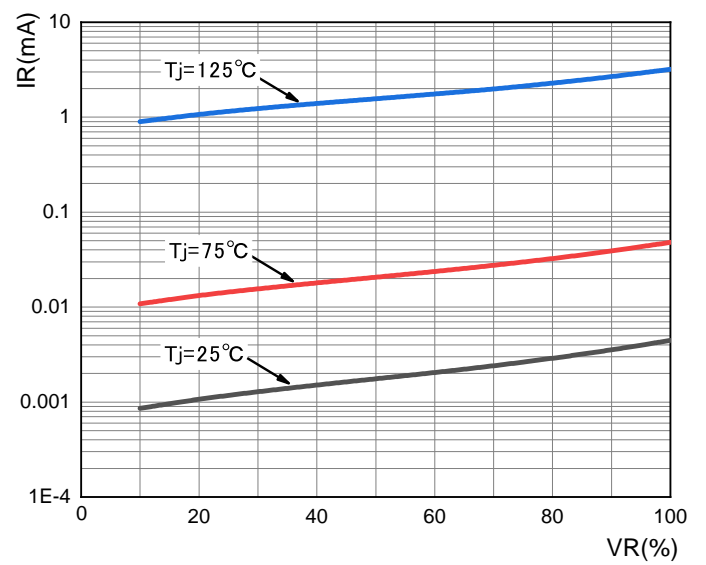

SK28-SK210

FIG.7: TYPICAL FORWARD CHARACTERISTICS

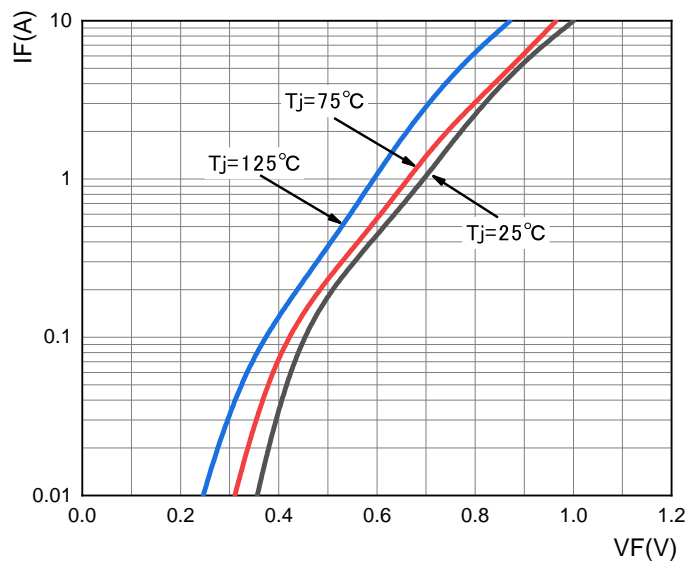

SK28-SK210

FIG.8: TYPICAL REVERSE CHARACTERISTICS

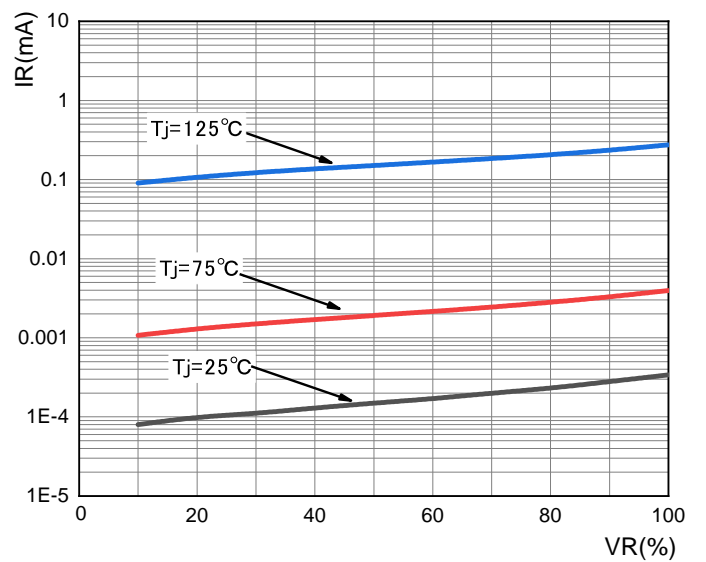

Typical Characteristics

SK215

FIG.9: TYPICAL FORWARD CHARACTERISTICS

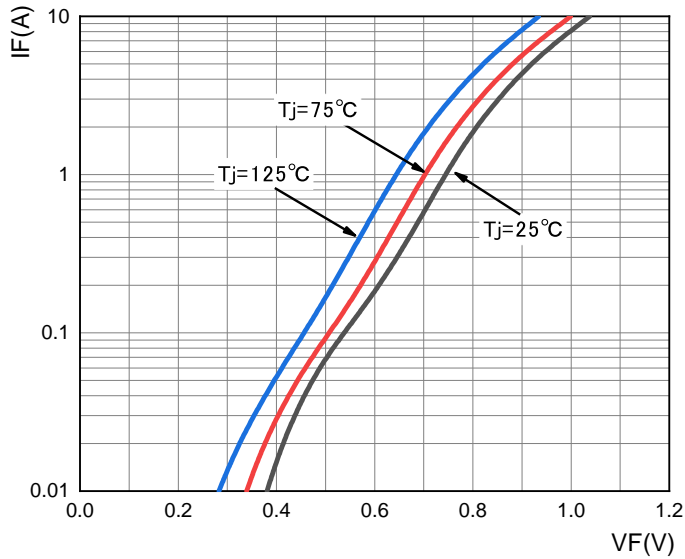

SK215

FIG.10: TYPICAL REVERSE CHARACTERISTICS

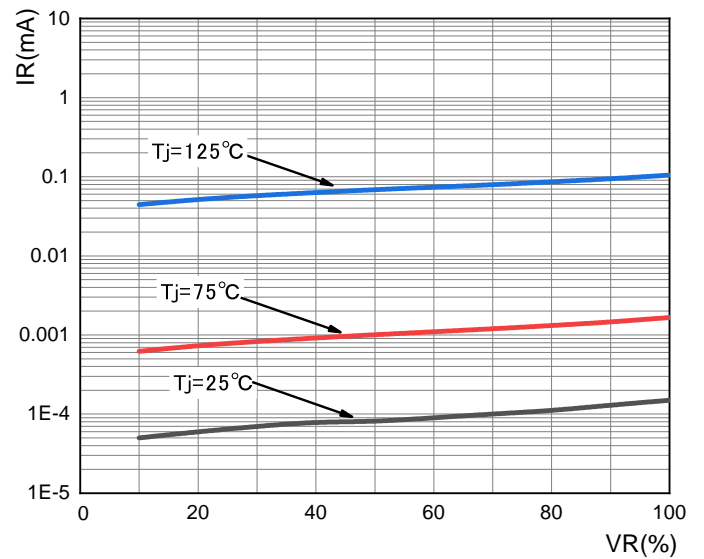

SK220

FIG.11: TYPICAL FORWARD CHARACTERISTICS

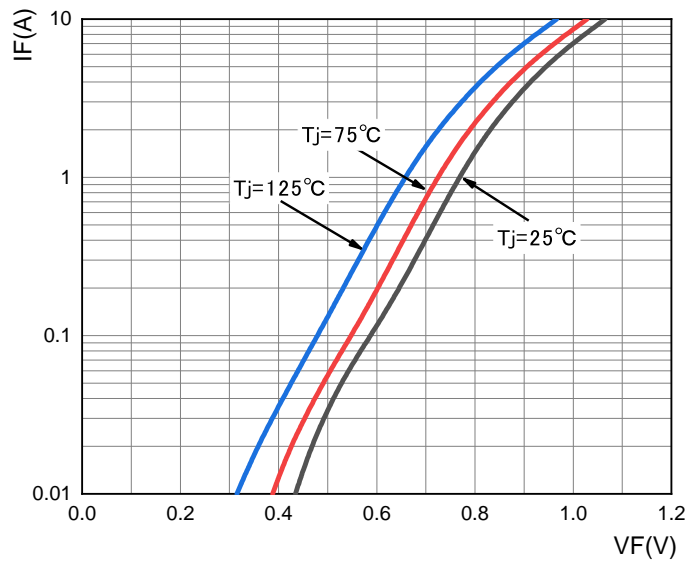

SK220

FIG.12: TYPICAL REVERSE CHARACTERISTICS

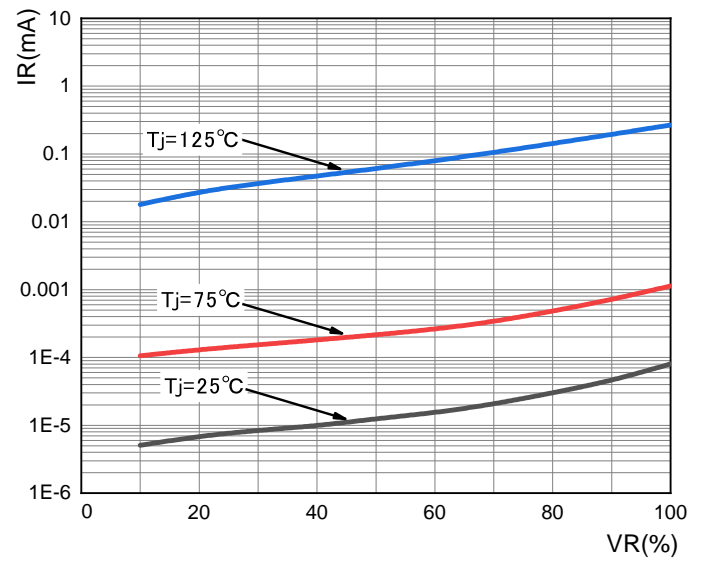

SMBG Package Outline Dimensions

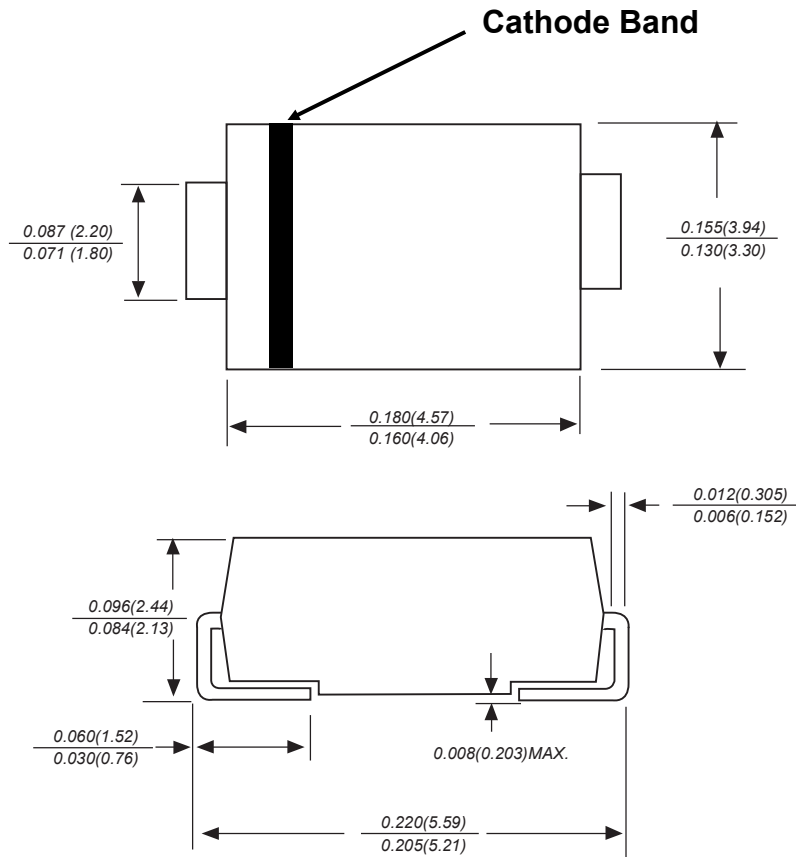

Dimensions in inches and (millimeters)

SMBG Suggested Pad Layout

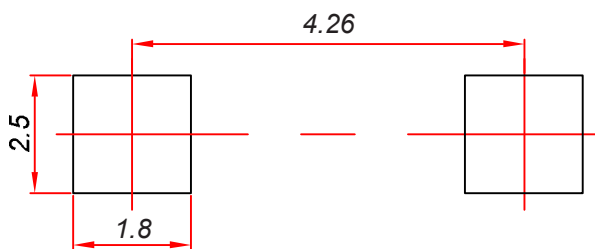

Note:

1. Controlling dimension: in millimeters.
2. General tolerance: ± 0.05 mm.
3. The pad layout is for reference purposes only.

NOTICE

JSCJ reserves the right to make modifications, enhancements, improvements, corrections or other changes without further notice to any product herein. JSCJ does not assume any liability arising out of the application or use of any product described herein.

Reel Taping Specifications For Surface Mount Devices- SMBG

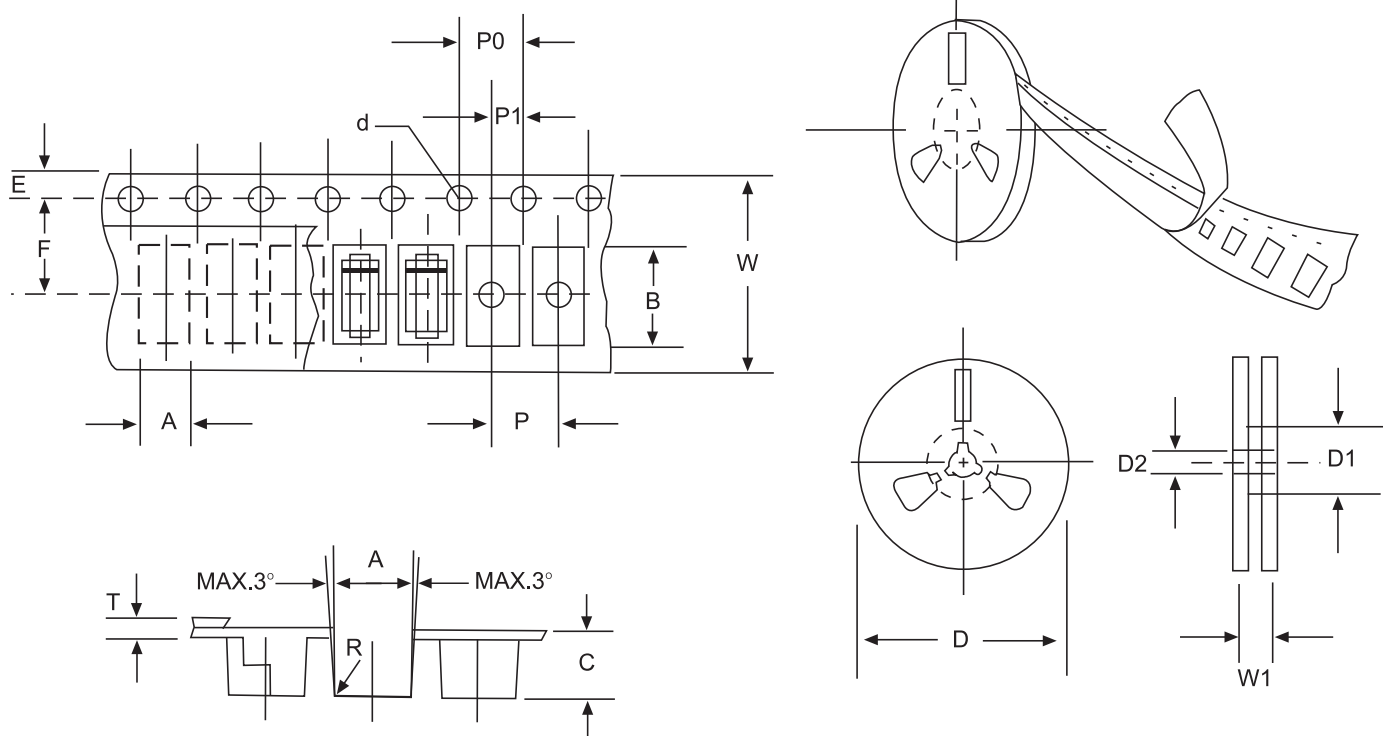

FIG: CONFIGURATION OF SURFACE MOUNTED DEVICES TAPING

ITEM	SYMBOL	SMBG mm(inch)
Carrier width	A	4.09±0.1(0.161±0.004)
Carrier length	B	5.82±0.1(0.229±0.004)
Carrier depth	C	2.50±0.1(0.100±0.004)
Sprocket hole	d	1.55±0.05(0.061±0.002)
Reel outside diameter	D	330±2.0(13±0.079)
Reel inner diameter	D1	75±1.0 (2.95 ±0.039)
Feed hole diameter	D2	13±0.5(0.512±0.020)
Sprocket hole position	E	1.75±0.1(0.069±0.004)
Punch hole position	F	5.65±0.05(0.222±0.002)
Punch hole pitch	P	8.0±0.1(0.315±0.004)
Sprocket hole pitch	P0	4.0±0.1(0.157±0.004)
Embossment center	P1	2.0±0.1(0.079±0.004)
Total tape thickness	T	0.32±0.1(0.013±0.004)
Tape width	W	12.0±0.2(0.472±0.008)
Reel width	W1	16.8±2.0(0.661±0.079)

NOTE: Devices are packed in accordance with EIA standard RS-481-A and specification given above.