

SK6021

Ultra Low Consumption 300mA CMOS Regulator

General Description

The SK6021 is a high accuracy, low noise, high speed CMOS Linear regulator with low power consumption and low dropout voltage, which provide large output currents even when the difference of the input-output voltage is small. The devices offer a new level of cost effective performance in cellular phones, laptop and notebook computers, and other portable devices.

The current limiter's fold-back circuit also operates as a short circuit protection and an output current limiter at the output pin.

The SK6021 regulators are available in standard SOT23-3, SOT23-5 and DFN1x1-4 packages. Standard products are Pb-free and Halogen-free.

Features

- Input voltage:1.5V~8V
- Output range:1.2V~5.0V
- Maximum output current: 400mA @ VOUT=3.3V
- PSRR: 60dB @1KHz
- Dropout voltage:160mV @ IOU=100mA
- Quiescent current: 0.8μA Typ.
- Shut-down current: <1μA
- Recommend capacitor:1μF
- Built-in Short-Circuit Protection, Current Limiter

Applications

- Radio control systems
- Cellphones, radiophone, digital cameras
- Bluetooth, wireless handsets
- Others portable consumer equipments

Application Circuits

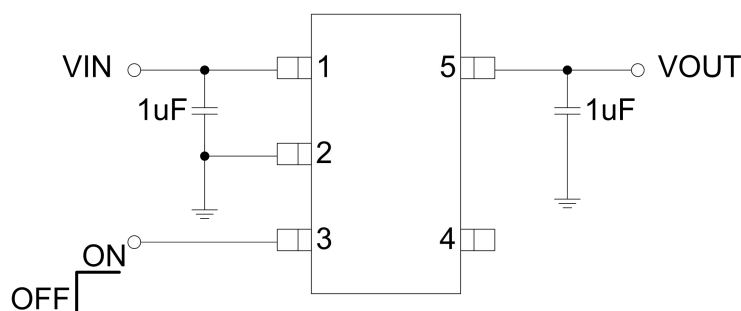

Ordering Information

Part No.	Package	Temperature	Tape & Reel
SK6021S3-XX	SOT23-3	-40 ~ +85 °C	3000/REEL
SK6021S5-XX	SOT23-5	-40 ~ +85 °C	3000/REEL
SK6021D4-XX	DFN1x1-4	-40 ~ +85 °C	10000/REEL

Note: XX indicates 1.2V~5.0V by 0.1V step. For example, 28 means product outputs 2.8V

Block Diagram

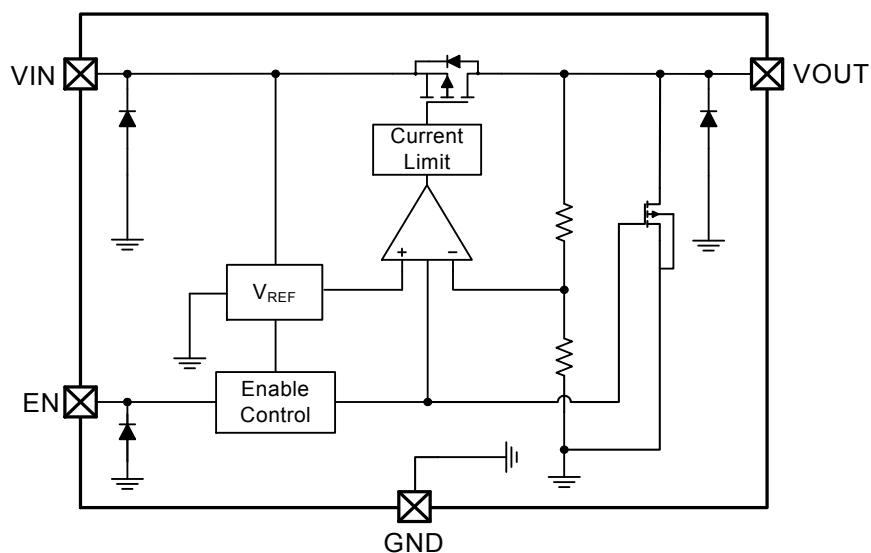

Pin Assignment

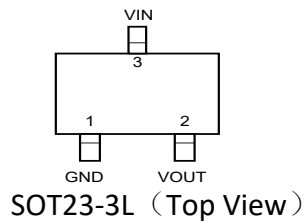

SK6021S3 (SOT23-3)

PIN NO.	PIN NAME	FUNCTION
1	GND	GND pin
2	VOUT	Output voltage pin
3	VIN	Input voltage pin

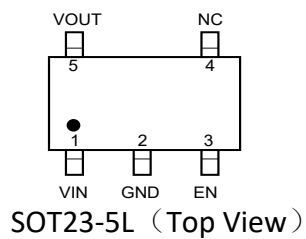

SK6021S5 (SOT23-5)

PIN NO	PIN NAME	FUNCTION
1	VIN	Input
2	GND	Ground
3	EN	Enable(Active high, not floating)
4	NC	Not connected
5	VOUT	Output

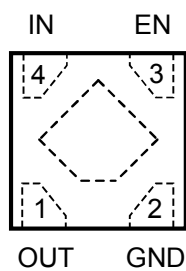

SK6021D4 (DFN1*1-4)

PIN NO	PIN NAME	FUNCTION
1	VOUT	Output
2	GND	Ground
3	EN	Enable(Active high, not floating)
4	VIN	Input

Absolute Maximum Ratings

Input Voltage.....	-0.3V to 9V	Storage Temperature	-55°C to 150°C
Output Current.....	450mA	Package Lead Soldering Temperature.....	260°C
Operating Temperature	-40°C to 85°C	Junction Temperature.....	-40°C to 125°C
Ambient Temperature.....	-40°C to 85°C		

Note: These are stress ratings only. Stresses exceeding the range specified under “Absolute Maximum Ratings” may cause substantial damage to the device. Functional operation of this device at other conditions beyond those listed in the specification is not implied and prolonged exposure to extreme conditions may affect device reliability.

Thermal Information

Symbol	Parameter	Package	Max.	Unit
θ_{JA}	Thermal Resistance (Junction to Ambient)(Assume no ambient airflow, no heat sink)	SOT23-3	500	°C/W
		SOT23-5	500	
		DFN1x1-4	500	
P_D	Power Dissipation	SOT23-3	0.40	W
		SOT23-5	0.40	
		DFN1x1-4	0.40	

Note: P_D is measured at $T_a = 25^\circ\text{C}$

Electrical Characteristics

The following specifications apply for $V_{OUT}=2.8\text{V}, T_A=25^\circ\text{C}$, unless specified otherwise

SYMBOL	ITEMS	CONDITIONS	MIN	TYP	MAX	UNIT
V_{IN}	Input Voltage		1.5	--	8	V
V_{OUT}	Output Range	$I_{OUT}=1\text{mA}$	-2	V_{OUT}	2	%
I_Q	Quiescent Current	$V_{OUT}=2.8\text{V}, I_{OUT}=0$		0.8		μA
I_{LIMIT}	Current Limit	$V_{IN}=V_{EN}=4.5\text{V}$		300	450	mA
V_{DROP}	Dropout Voltage	$V_{OUT}=3.3\text{V}, I_{OUT}=100\text{mA}$		150		mV
		$V_{OUT}=3.3\text{V}, I_{OUT}=200\text{mA}$		320		
ΔV_{LINE}	Line Regulation	$V_{IN}=2.7\sim 5.5\text{V}, I_{OUT}=1\text{mA}$		0.01	0.15	%/V
ΔV_{LOAD}	Load Regulation	$V_{OUT}=3.3\text{V}, I_{OUT}=1\sim 300\text{mA}$		200		mV
I_{SHORT}	Short Current	$V_{EN}=V_{IN}, V_{OUT}$ Short to GND with 1Ω		30		mA
I_{SHDN}	Shut-down Current	$V_{EN}=0\text{V}$			1	μA
PSRR	Power Supply Rejection Rate	$V_{IN}=5V_{DC}+0.5V_{P-P}$ $F=1\text{KHz}, I_{OUT}=10\text{mA}$		60		dB
V_{ENH}	EN logic high voltage	$V_{IN}=5.5\text{V}, I_{OUT}=1\text{mA}$	1.2		V_{IN}	V
V_{ENL}	EN logic low voltage	$V_{IN}=5.5\text{V}, V_{OUT}=0\text{V}$			0.4	V
I_{EN}	EN Input Current	$V_{EN}=0$ to 5.5V			1	μA

Typical Performance Characteristics

$C_{IN}=1\mu F$, $C_{OUT}=1\mu F$, $V_{IN}=4.5V$, $V_{OUT}=3.3V$ $T_A=25^\circ C$, unless specified otherwise. Package: SOT23-5L

(1) Quiescent current vs Input voltage

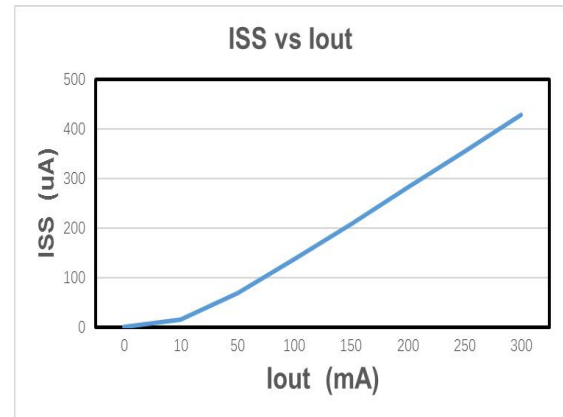
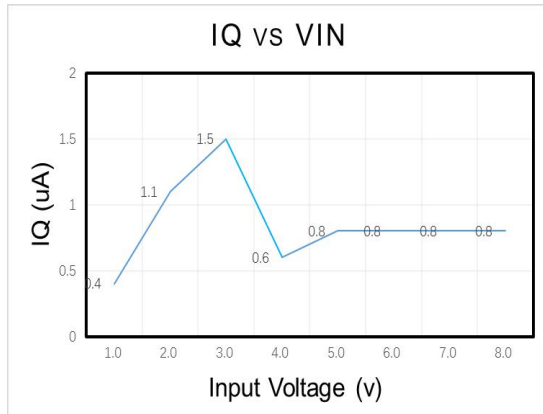

(2) Output Voltage vs Input voltage

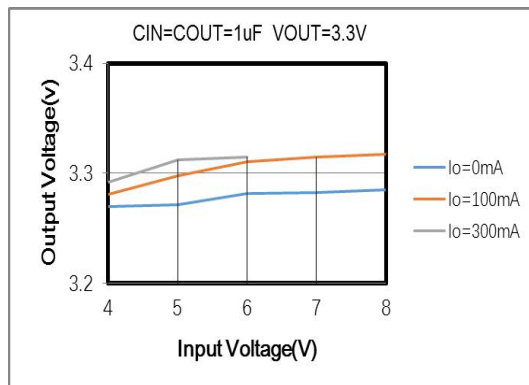

(3) Output Voltage vs Temperature

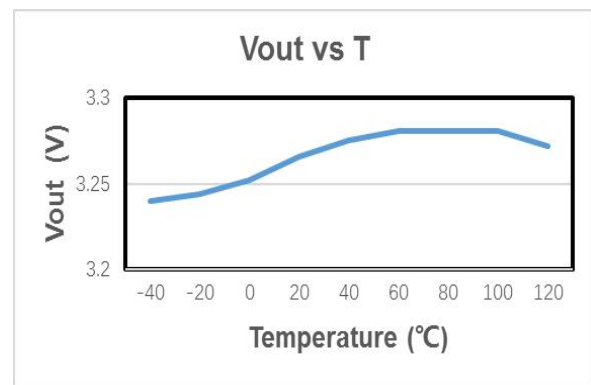

Application Information

In general, all the capacitors need to be low leakage. Any leakage the capacitors have will reduce efficiency, increase the quiescent current.

A recent trend in the design of portable devices has been to use ceramic capacitors to filter DC-DC converter inputs. Ceramic capacitors are often chosen because of their small size, low equivalent series resistance (ESR) and high RMS current capability. Also, recently, designers have been looking to ceramic capacitors due to shortages of tantalum capacitors. Unfortunately, using ceramic capacitors for input filtering can cause problems. Applying a voltage step to a ceramic capacitor causes a large current surge that stores energy in the inductances of the power leads. A large voltage

spike is created when the stored energy is transferred from these inductances into the ceramic capacitor. These voltage spikes can easily be twice the amplitude of the input voltage step.

Many types of capacitors can be used for input bypassing, however, caution must be exercised when using multilayer ceramic capacitors (MLCC). Because of the self-resonance generated under some start-up conditions, such as connecting the LDO input to a live power source.

The LDO also requires an output capacitor for loop stability. Connect a 1uF tantalum capacitor from OUT to GND close to the pins. For improved transient response, this output capacitor may be ceramic.

Package Information

3-pin SOT23-3 Outline Dimensions

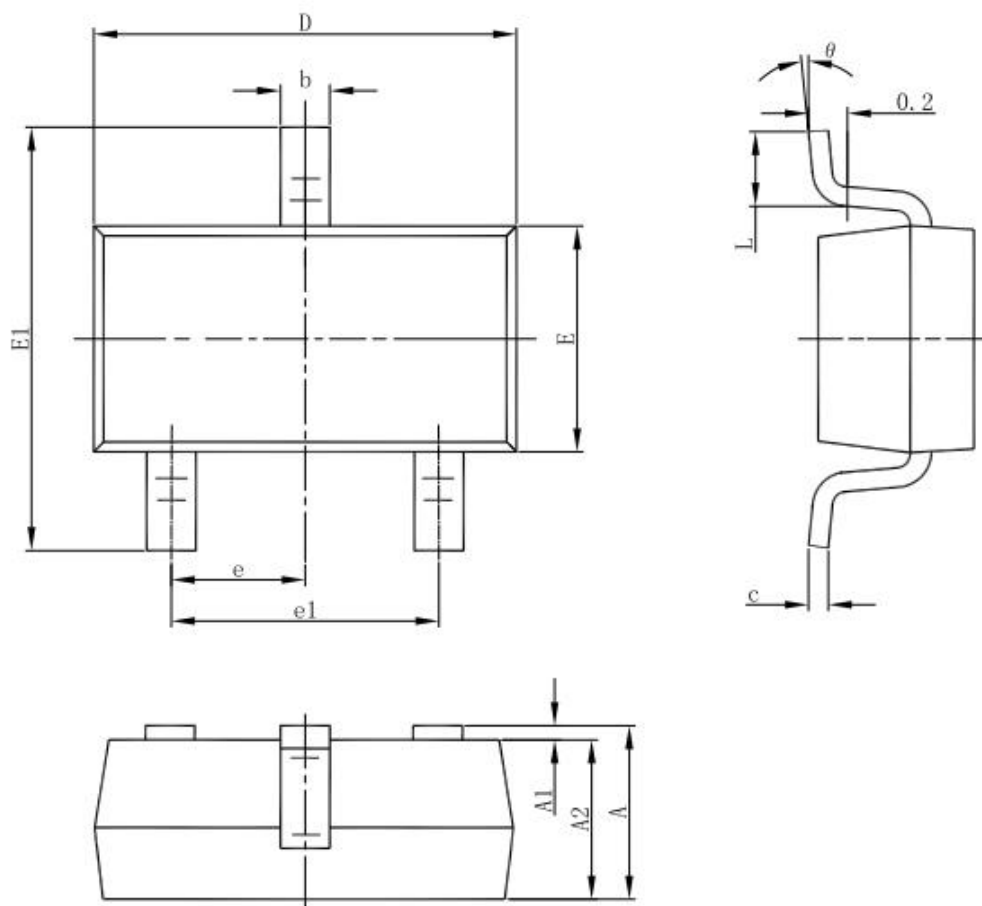

Symbol	Dimensions In Millimeters		Dimensions In Inches	
	Min	Max	Min	Max
A	1.050	1.250	0.041	0.049
A1	0.000	0.100	0.000	0.004
A2	1.050	1.150	0.041	0.045
b	0.300	0.500	0.012	0.020
c	0.100	0.200	0.004	0.008
D	2.820	3.020	0.111	0.119
E	1.500	1.700	0.059	0.067
E1	2.650	2.950	0.104	0.116
e	0.950(BSC)		0.037(BSC)	
e1	1.800	2.000	0.071	0.079
L	0.300	0.600	0.012	0.024
θ	0°	8°	0°	8°

SOT23-5 Outline Dimensions

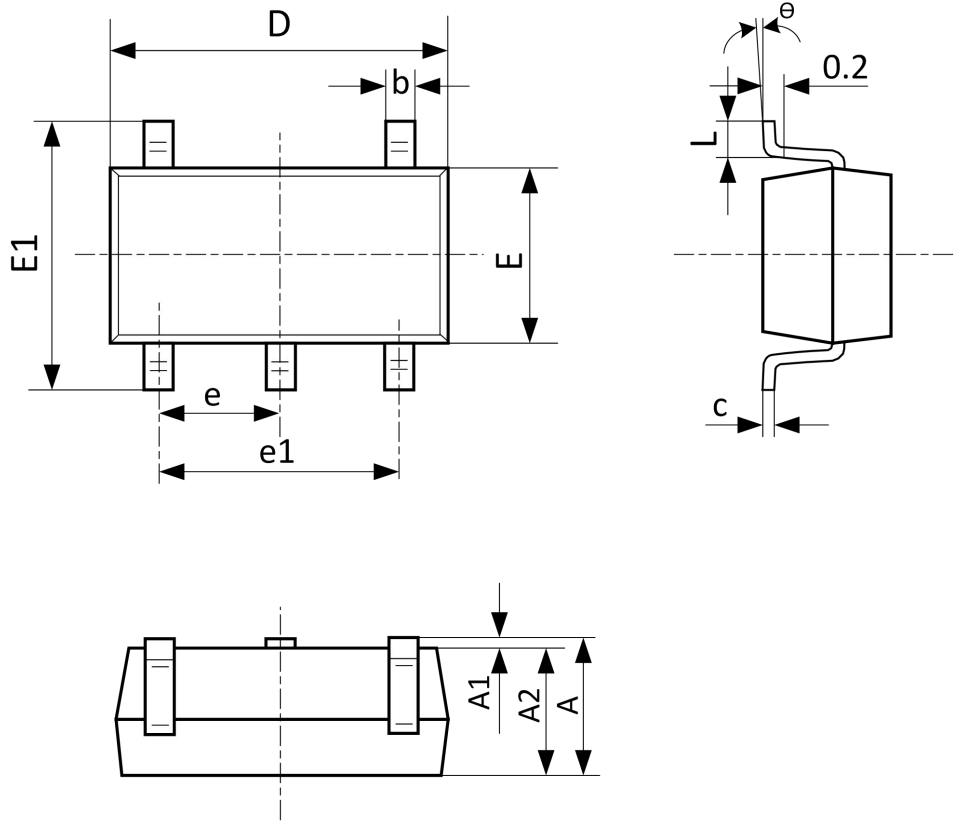

Symbol	Dimensions In Millimeters		Dimensions In Inches	
	Min	Max	Min	Max
A	1.050	1.250	0.041	0.049
A1	0.000	0.100	0.000	0.004
A2	1.050	1.150	0.041	0.045
b	0.300	0.500	0.012	0.020
c	0.100	0.200	0.004	0.008
D	2.820	3.020	0.111	0.119
E	1.500	1.700	0.059	0.067
E1	2.650	2.950	0.104	0.116
e	0.950(BSC)		0.037(BSC)	
e1	1.800	2.000	0.071	0.079
L	0.300	0.600	0.012	0.024
θ	0°C	8°C	0°C	8°C

DFN1x1-4 Outline Dimensions

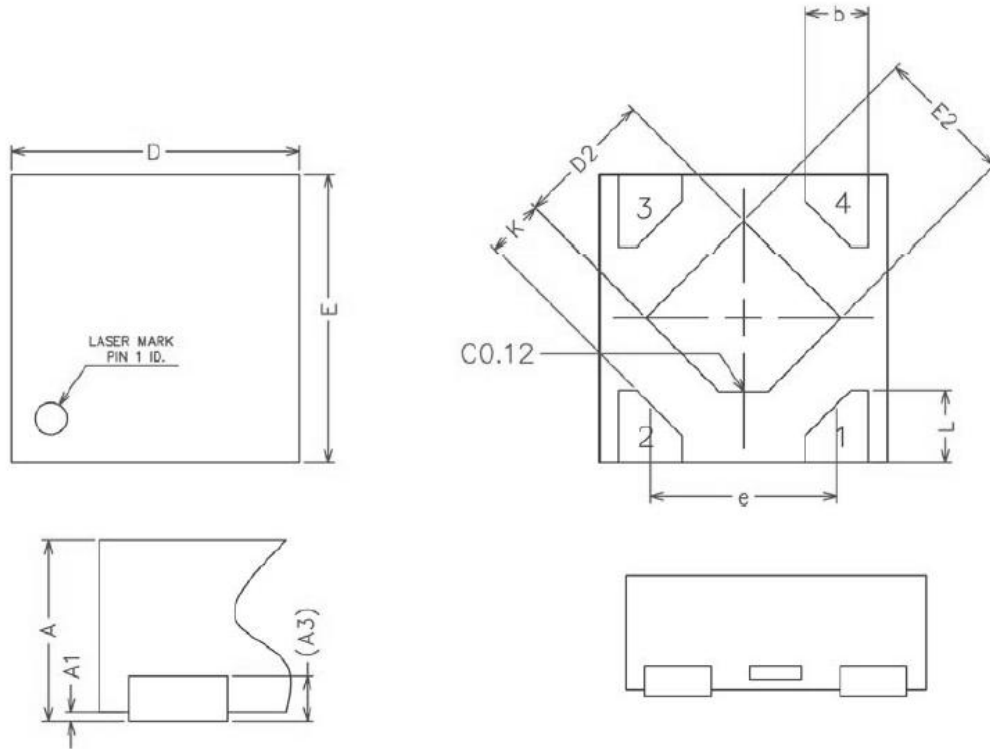

COMMON DIMENSIONS
(UNITS OF MEASURE=MILLIMETER)

SYMBOL	MIN	NOM	MAX
A	0.34	0.37	0.40
A1	0.00	0.02	0.05
A3	0.100REF		
b	0.17	0.22	0.27
D	0.95	1.00	1.05
E	0.95	1.00	1.05
D2	0.43	0.48	0.53
E2	0.43	0.48	0.53
L	0.20	0.25	0.30
e	—	0.65	—
K	0.15	—	—