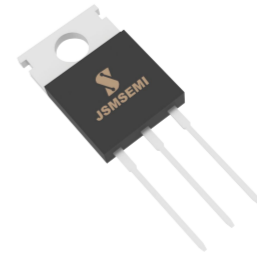

**DESCRIPTION**

- Collector-Emitter Voltage-  
:  $V_{CER} = 75V(\text{Min}) ; R_{BE} = 150 \Omega$
- Collector Current-  
:  $I_C = 3A$

**APPLICATIONS**

- 27MHz RF Power Amplifier Applications

**ABSOLUTE MAXIMUM RATINGS ( $T_a = 25^\circ\text{C}$ )**

SYMBOL	PARAMETER	VALUE	UNIT
$V_{CBO}$	Collector-Base Voltage	80	V
$V_{CER}$	Collector-Emitter Voltage $R_{BE} = 150 \Omega$	75	V
$V_{EBO}$	Emitter-Base Voltage	5	V
$I_C$	Collector Current-Continuous	3	A
$I_{CM}$	Collector Current-Peak	5	A
$P_C$	Collector Power Dissipation @ $T_a = 25^\circ\text{C}$	1.2	W
	Collector Power Dissipation @ $T_c = 50^\circ\text{C}$	10	
$T_J$	Junction Temperature	150	$^\circ\text{C}$
$T_{stg}$	Storage Temperature Range	-55~150	$^\circ\text{C}$

**ELECTRICAL CHARACTERISTICS**
 $T_C=25^{\circ}\text{C}$  unless otherwise specified

SYMBOL	PARAMETER	CONDITIONS	MIN	TYP.	MAX	UNIT
$V_{(BR)CBO}$	Collector-Base Breakdown Voltage	$I_C=0.1\text{mA}; I_B=0$	80			V
$V_{(BR)CER}$	Collector-Emitter Breakdown Voltage	$I_C=0.1\text{mA}; R_{BE}=150\ \Omega$	75			V
$V_{(BR)EBO}$	Emitter-Base Breakdown Voltage	$I_E=0.1\text{mA}; I_C=0$	5			V
$V_{CE(sat)}$	Collector-Emitter Saturation Voltage	$I_C=1\text{A}; I_B=0.1\text{A}$			0.6	V
$V_{BE(sat)}$	Base-Emitter Saturation Voltage	$I_C=1\text{A}; I_B=0.1\text{A}$			1.2	V
$I_{CBO}$	Collector Cutoff Current	$V_{CB}=40\text{V}; I_E=0$			10	$\mu\text{A}$
$I_{EBO}$	Emitter Cutoff Current	$V_{EB}=4\text{V}; I_C=0$			10	$\mu\text{A}$
$h_{FE}$	DC Current Gain	$I_C=500\text{mA}; V_{CE}=5\text{V}$	25		200	
$C_{OB}$	Output Capacitance	$I_E=0; V_{CB}=10\text{V}; f_{test}=1\text{MHz}$		45	60	pF
$f_T$	Current-Gain—Bandwidth Product	$I_C=500\text{mA}; V_{CE}=10\text{V}$	100			MHz
$P_O$	Output Power	$V_{CC}=12\text{V}; P_{in}=0.2\text{W}, f=27\text{MHz}$	4.0			W
$\eta$	Power Efficiency		60			%

**◆  $h_{FE}$  Classifications**

B	C	D	E
25-50	40-80	60-120	100-200

### Package Information

TO-220

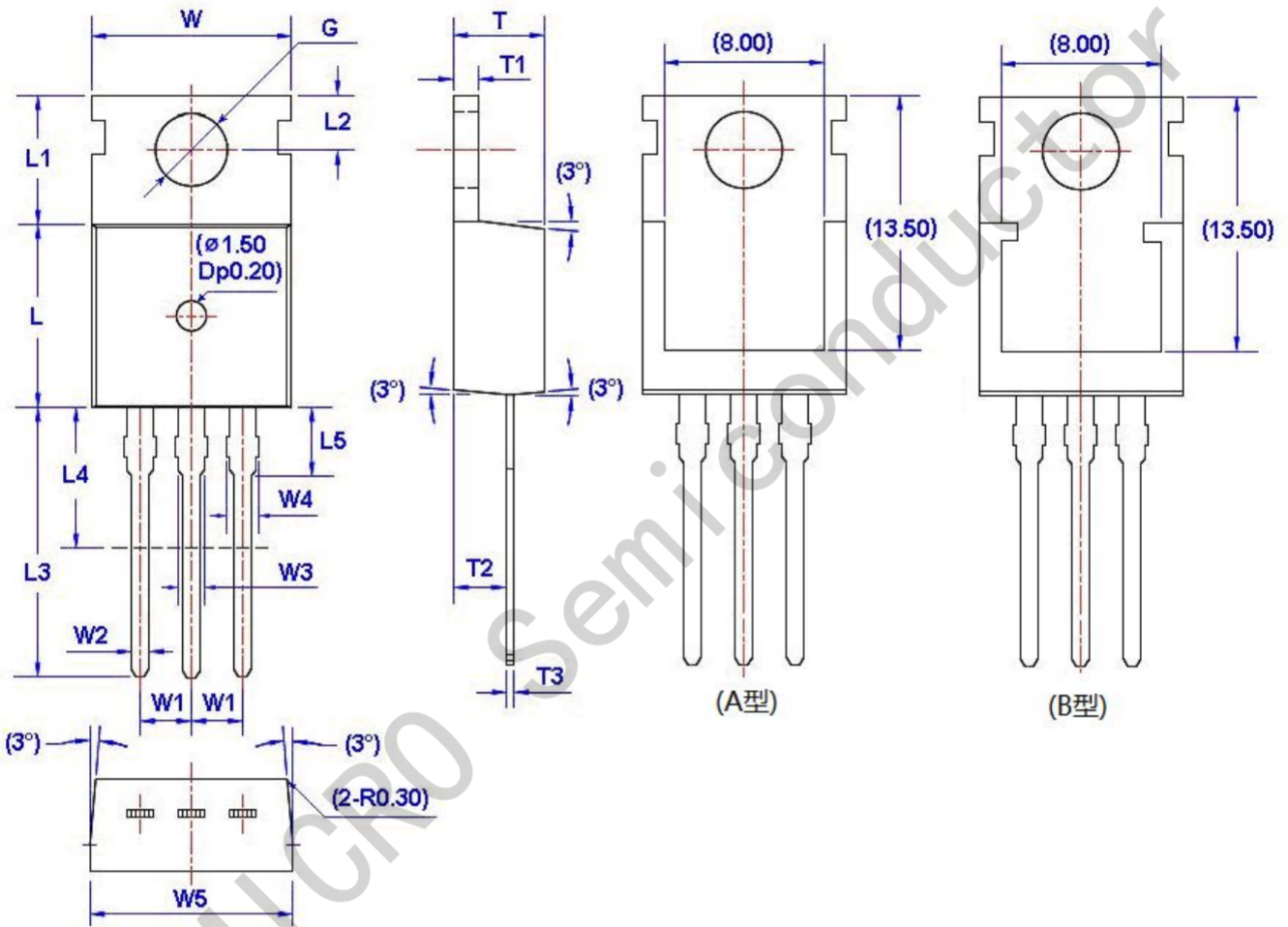

Unit: mm

Symbol	Size		Symbol	Size		Symbol	Size		Symbol	Size	
	Min	Max		Min	Max		Min	Max		Min	Max
W	9.66	10.28	W5	9.80	10.20	L4**	6.20	6.60	T3	0.45	0.60
W1	2.54 (TYP)		L	9.00	9.40	L5	2.79	3.30	G( $\Phi$ )	3.50	3.70
W2	0.70	0.95	L1	6.40	6.80	T	4.30	4.70			
W3	1.17	1.37	L2	2.70	2.90	T1	1.15	1.40			
W4*	1.32	1.72	L3	12.70	14.27	T2	2.20	2.60			