

**DESCRIPTION**

- With TO-220C package
- High voltage ,high speed

**APPLICATIONS**

- Particularly suited for 115V and 220V switchmode applications such as switching regulators,inverters ,motor controls,solenoid/ relay drivers and deflection circuits

**Absolute maximum ratings(Tc=25°C)**

SYMBOL	PARAMETER	CONDITIONS	VALUE	UNIT
V <sub>CBO</sub>	Collector-base voltage	Open emitter	700	V
V <sub>CEO</sub>	Collector-emitter voltage	Open base	400	V
V <sub>EBO</sub>	Emitter-base voltage	Open collector	9	V
I <sub>C</sub>	Collector current (DC)		8	A
I <sub>CM</sub>	Collector current-Peak		16	A
I <sub>B</sub>	Base current		4	A
I <sub>BM</sub>	Base current-Peak		8	A
I <sub>E</sub>	Emitter current		12	A
I <sub>EM</sub>	Emitter current-Peak		24	A
P <sub>D</sub>	Total power dissipation	T <sub>C</sub> =25°C	80	W
T <sub>J</sub>	Junction temperature		150	°C
T <sub>stg</sub>	Storage temperature		-65~150	°C

**THERMAL CHARACTERISTICS**

SYMBOL	PARAMETER	VALUE	UNIT
R <sub>th j-c</sub>	Thermal resistance from junction to case	1.56	°C/W

**CHARACTERISTICS**

 T<sub>j</sub>=25°C unless otherwise specified

SYMBOL	PARAMETER	CONDITIONS	MIN	TYP.	MAX	UNIT
V <sub>CEO(SUS)</sub>	Collector-emitter sustaining voltage	I <sub>C</sub> =10mA; I <sub>B</sub> =0	400			V
V <sub>CEsat-1</sub>	Collector-emitter saturation voltage	I <sub>C</sub> =2A; I <sub>B</sub> =0.4A			1.0	V
V <sub>CEsat-2</sub>	Collector-emitter saturation voltage	I <sub>C</sub> =5A; I <sub>B</sub> =1.0A T <sub>C</sub> =100°C			2.0 3.0	V
V <sub>CEsat-3</sub>	Collector-emitter saturation voltage	I <sub>C</sub> =8A; I <sub>B</sub> =2.0A			3.0	V
V <sub>BEsat-1</sub>	Base-emitter saturation voltage	I <sub>C</sub> =2A; I <sub>B</sub> =0.4A			1.2	V
V <sub>BEsat-2</sub>	Base-emitter saturation voltage	I <sub>C</sub> =5A; I <sub>B</sub> =1.0A T <sub>C</sub> =100°C			1.6 1.5	V
I <sub>CBO</sub>	Collector cut-off current	V <sub>CB</sub> =700V; I <sub>E</sub> =0 T <sub>C</sub> =125°C			0.1 1.0	mA
I <sub>EBO</sub>	Emitter cut-off current	V <sub>EB</sub> =9V; I <sub>C</sub> =0			0.1	mA
h <sub>FE-1</sub>	DC current gain	I <sub>C</sub> =2A; V <sub>CE</sub> =5V	8		40	
h <sub>FE-2</sub>	DC current gain	I <sub>C</sub> =5A; V <sub>CE</sub> =5V	5		30	
f <sub>T</sub>	Transition frequency	I <sub>C</sub> =0.5A; V <sub>CE</sub> =10V; f=1MHz	4			MHz
C <sub>OB</sub>	Collector output capacitance	I <sub>E</sub> =0; f=0.1MHz; V <sub>CB</sub> =10V		80		pF
Switching times resistive load						
t <sub>d</sub>	Delay time	V <sub>CC</sub> =125V, I <sub>C</sub> =5A I <sub>B1</sub> =-I <sub>B2</sub> =1.0A t <sub>p</sub> =25 μs duty cycle ≤ 1%			0.1	μs
t <sub>r</sub>	Rise time				1.5	μs
t <sub>s</sub>	Storage time				3.0	μs
t <sub>f</sub>	Fall time				0.7	μs

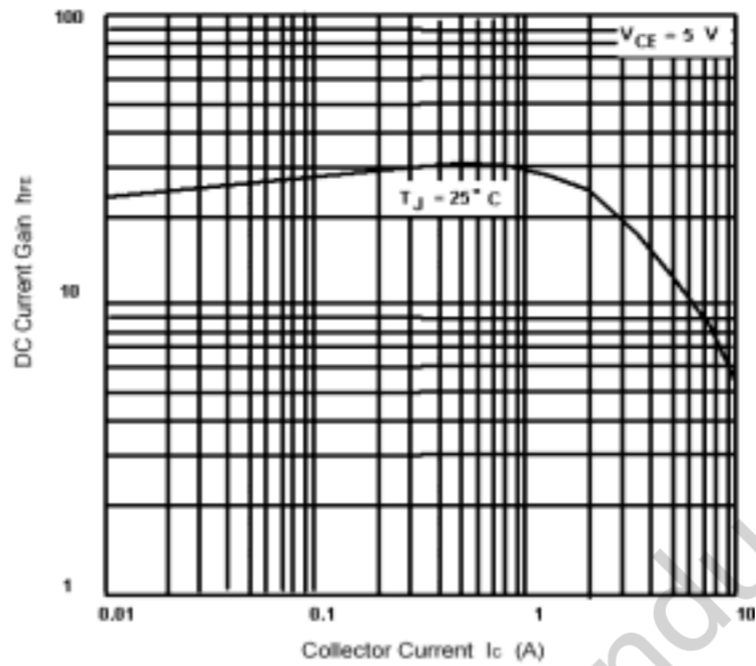

Fig.3 DC current Gain

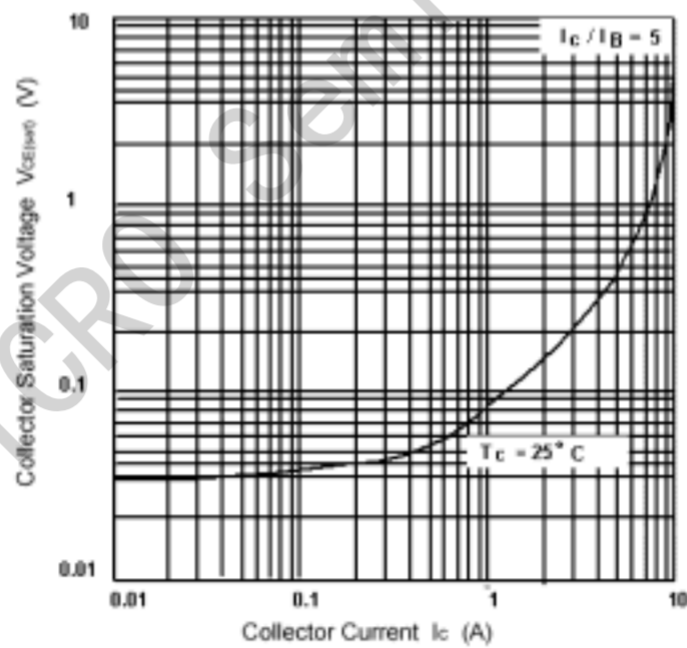

Fig.4 Collector-Emitter Saturation Voltage

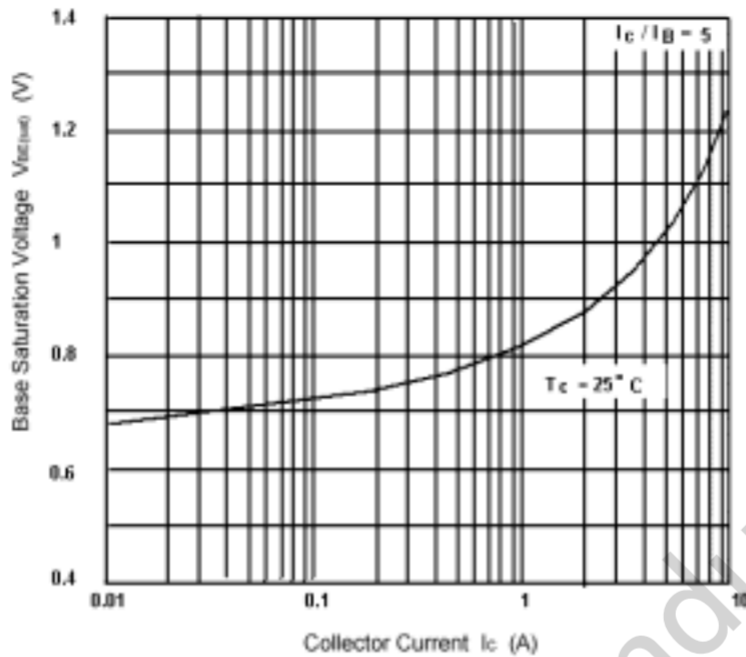

Fig.5 Base-Emitter Saturation Voltage

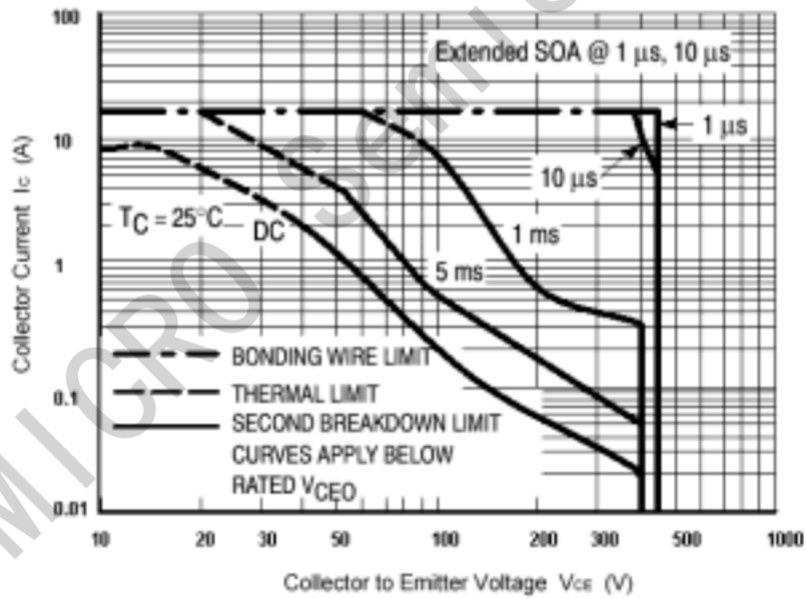
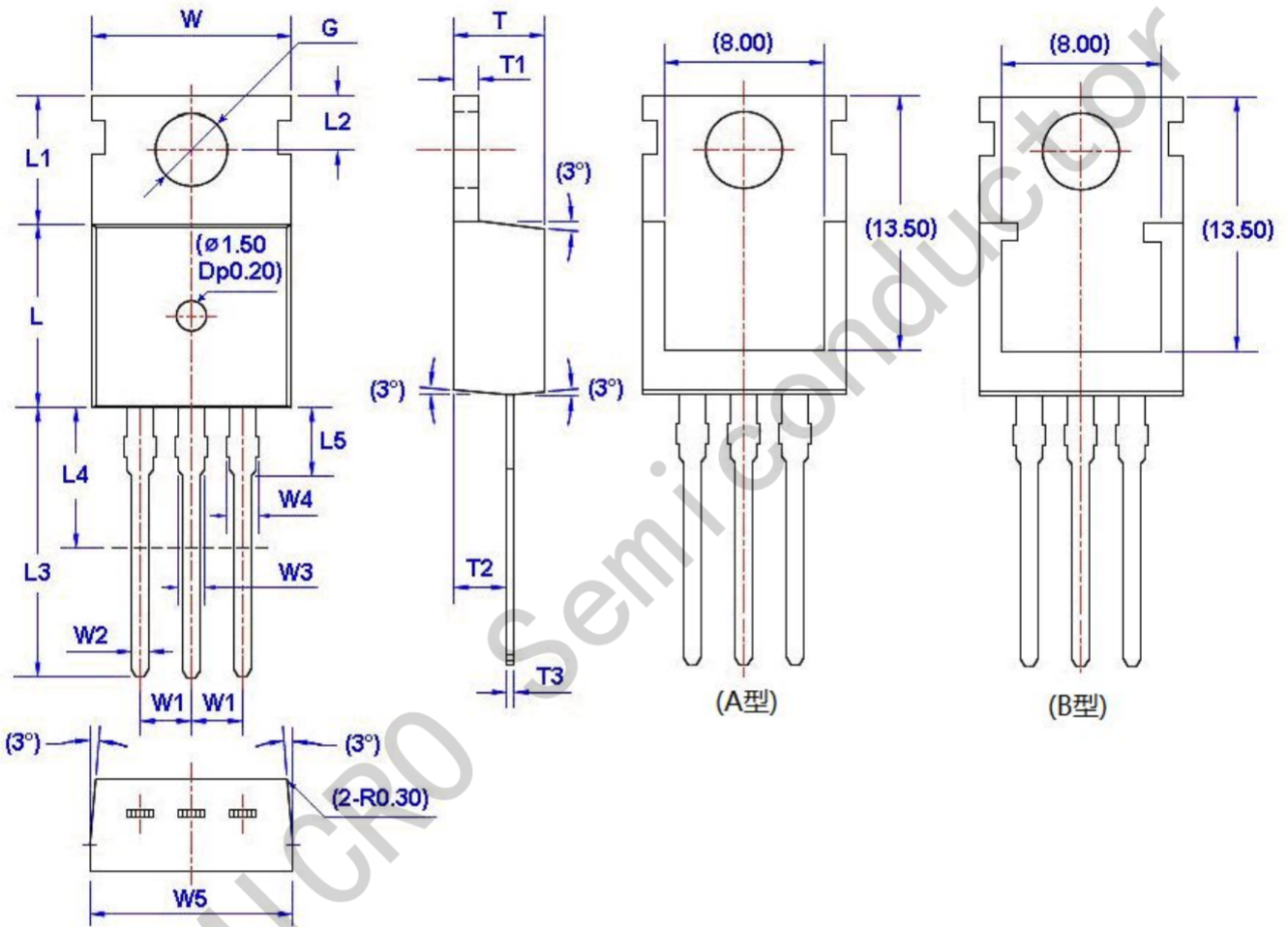

Fig.6 Safe Operating Area

### Package Information

TO-220



Unit: mm

Symbol	Size		Symbol	Size		Symbol	Size		Symbol	Size	
	Min	Max		Min	Max		Min	Max		Min	Max
W	9.66	10.28	W5	9.80	10.20	L4**	6.20	6.60	T3	0.45	0.60
W1	2.54 (TYP)		L	9.00	9.40	L5	2.79	3.30	G(Φ)	3.50	3.70
W2	0.70	0.95	L1	6.40	6.80	T	4.30	4.70			
W3	1.17	1.37	L2	2.70	2.90	T1	1.15	1.40			
W4*	1.32	1.72	L3	12.70	14.27	T2	2.20	2.60			