

TR Z00.60/06b II

Outline Drawing

1. Physical Dimension (UNIT: mm)

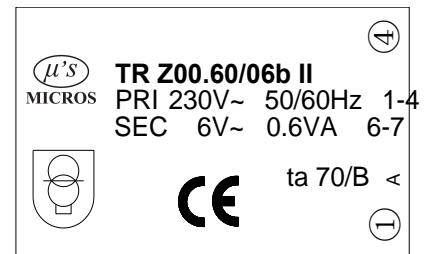
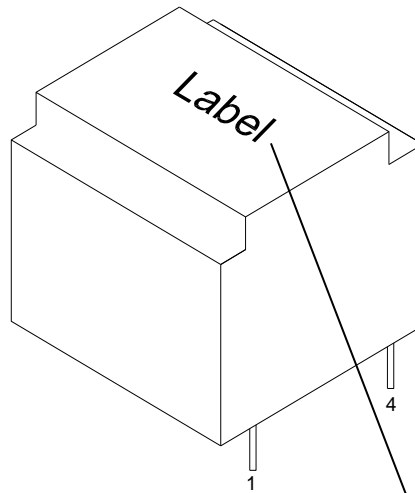
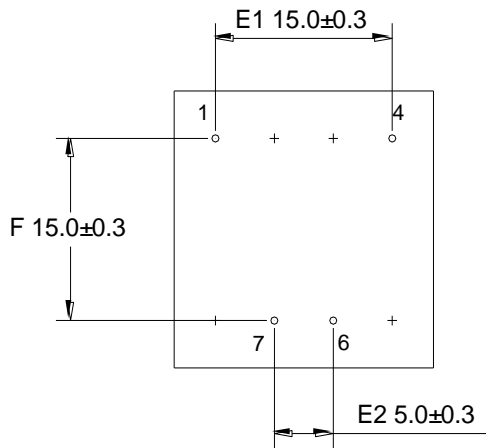
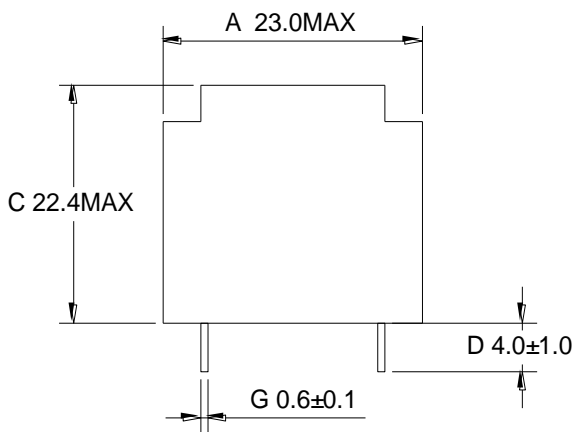

Electrical Performance

1、SAFETY STANDARD: EN61558 _____

2、ELECTRICAL PERFORMANCE:

2-1. PRIMARY RATED VOLTAGE: AC 230 V / 50 Hz

EXCITING CURRENT: _____ 12 mA MAX.

2-2. SECONDARY RATED VOLTAGE AND CURRENT:

	UNLOAD VOLTAGE	LOADING VOLTAGE	RATED CURRENT	DC RESISTANCE T=25°C
P: 1--4	/			10000Ω MAX
S: 6--7	8VAC ±10%	6VAC ±10%	100mA	14.5Ω MAX

3、INSULATION RESISTANCE TEST:

500V DC 100MΩ min. FOR 1 MIN. (PRODUCTION LINE FOR 2S.) (PRI-SEC. & PRI.-CORE)

4、HI-POT TEST:

SHALL WITHSTAND WITHOUT BREAKDOWN

AC 3.75 KV FOR 1 MIN. OR AC 4.2 KV FOR 1S. (PRI.-SEC. & PRI.-CORE.)

(CUT-OFF CURRENT 1 mA)

5、TEMPERATURE RISE TEST: (Ta=25°C INPUT 230V 50Hz)

PRI. & SEC. WINDING'S TEMPERATURE RISE 45°C MAX. AT RATED LOAD. (RESISTANCE METHOD)

6、ELECTRICAL SCHEMATIC:

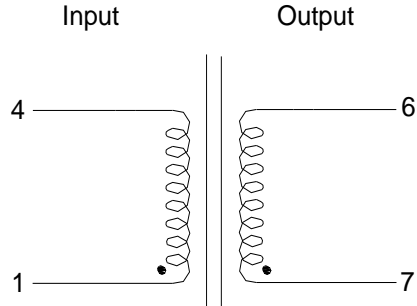

7、MAJOR MEASUREMENT FACILITIES:

A、DC-RESISTANCE METER: TH2512B

B、VOLTMETER: GDW4033A

C、AMPEREMETER: GDW4033A

D、TURN RATIO DETECTOR: YG-108R

E、HI-POT TESTER: CS5603

F、INSULATION-RESISTANCE METER: CS5603

G、MILIVOLTMETER: FLUCK 287

H、MULTI-FUNCTION OSCILLOSCOPE: DS-8608A

✓
✓
✓
✓
✓
✓

8、THE ABOVE-MENTIONED MEASUREMENT IS BASED ON THE BEGINNING OF AMBIENT TEMPERATURE.

9、Net Weight: 42 g/PCS