

- Wide Operating Voltage Range of 2 V to 6 V
- Outputs Can Drive Up To 10 LSTTL Loads
- Low Power Consumption, 20- μ A Max I_{CC}
- Typical $t_{pd} = 8$ ns
- ± 4 -mA Output Drive at 5 V
- Low Input Current of 1 μ A Max

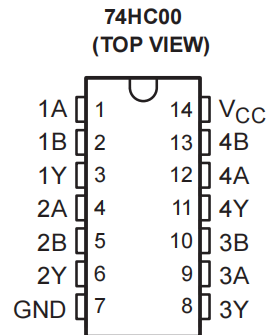

description/ordering information

The 'HC00 devices contain four independent 2-input NAND gates. They perform the Boolean function $Y = \overline{A \cdot B}$ or $Y = \overline{A} + \overline{B}$ in positive logic.

FUNCTION TABLE
(each gate)

INPUTS		OUTPUT
A	B	Y
H	H	L
L	X	H
X	L	H

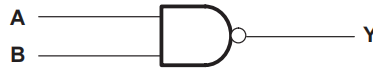

absolute maximum ratings over operating free-air temperature range (unless otherwise noted)†

Supply voltage range, V_{CC}	-0.5 V to 7 V
Input clamp current, I_{IK} ($V_I < 0$ or $V_I > V_{CC}$) (see Note 1)	±20 mA
Output clamp current, I_{OK} ($V_O < 0$ or $V_O > V_{CC}$) (see Note 1)	±20 mA
Continuous output current, I_O ($V_O = 0$ to V_{CC})	±25 mA
Continuous current through V_{CC} or GND	±50 mA
Package thermal impedance, (see Note 2): D package	86 C/W

recommended operating conditions (see Note 3)

		SN74HC00			UNIT
		MIN	NOM	MAX	
V_{CC}	Supply voltage	2	5	6	V
V_{IH}	High-level input voltage	$V_{CC} = 2\text{ V}$	1.5		V
		$V_{CC} = 4.5\text{ V}$	3.15		
		$V_{CC} = 6\text{ V}$	4.2		
V_{IL}	Low-level input voltage	$V_{CC} = 2\text{ V}$	0.5		V
		$V_{CC} = 4.5\text{ V}$	1.35		
		$V_{CC} = 6\text{ V}$	1.8		
V_I	Input voltage	0	V_{CC}		V
V_O	Output voltage	0	V_{CC}		V
$\Delta t/\Delta v$	Input transition rise/fall time	$V_{CC} = 2\text{ V}$	1000		ns
		$V_{CC} = 4.5\text{ V}$	500		
		$V_{CC} = 6\text{ V}$	400		
T_A	Operating free-air temperature	-40	85		°C

electrical characteristics over recommended operating free-air temperature range (unless otherwise noted)

PARAMETER	TEST CONDITIONS		V _{CC}	T _A = 25°C			SN74HC00		UNIT
				MIN	TYP	MAX	MIN	MAX	
V _{OH}	V _I = V _{IH} or V _{IL}	I _{OH} = -20 μA	2 V	1.9	1.998		1.9	V	
			4.5 V	4.4	4.499		4.4		
			6 V	5.9	5.999		5.9		
		I _{OH} = -4 mA	4.5 V	3.98	4.3		3.84		
		I _{OH} = -5.2 mA	6 V	5.48	5.8		5.34		
V _{OL}	V _I = V _{IH} or V _{IL}	I _{OL} = 20 μA	2 V		0.002	0.1		V	
			4.5 V		0.001	0.1			0.1
			6 V		0.001	0.1			0.1
		I _{OL} = 4 mA	4.5 V		0.17	0.26			0.33
		I _{OL} = 5.2 mA	6 V		0.15	0.26			0.33
I _I	V _I = V _{CC} or 0		6 V		±0.1	±100		±1000	nA
I _{CC}	V _I = V _{CC} or 0, I _O = 0		6 V				2	20	μA
C _i			2 V to 6 V		3	10		10	pF

switching characteristics over recommended operating free-air temperature range, C_L = 50 pF (unless otherwise noted) (see Figure 1)

PARAMETER	FROM (INPUT)	TO (OUTPUT)	V _{CC}	T _A = 25°C			SN74HC00		UNIT
				MIN	TYP	MAX	MIN	MAX	
t _{pd}	A or B	Y	2 V		45	90		115	ns
			4.5 V		9	18		23	
			6 V		8	15		20	
t _t		Y	2 V		38	75		95	ns
			4.5 V		8	15		19	
			6 V		6	13		16	

operating characteristics, T_A = 25°C

PARAMETER	TEST CONDITIONS	TYP	UNIT
C _{pd} Power dissipation capacitance per gate	No load	20	pF

PARAMETER MEASUREMENT INFORMATION

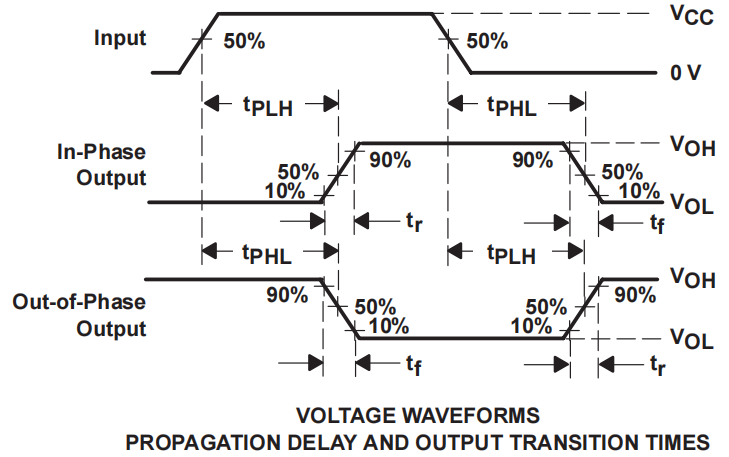
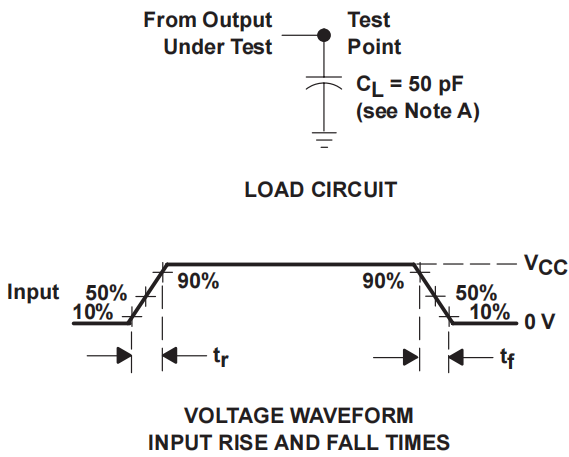

- NOTES: A. C_L includes probe and test-fixture capacitance.
 B. Phase relationships between waveforms were chosen arbitrarily. All input pulses are supplied by generators having the following characteristics: $PRR \leq 1 \text{ MHz}$, $Z_O = 50 \Omega$, $t_r = 6 \text{ ns}$, $t_f = 6 \text{ ns}$.

DIP14

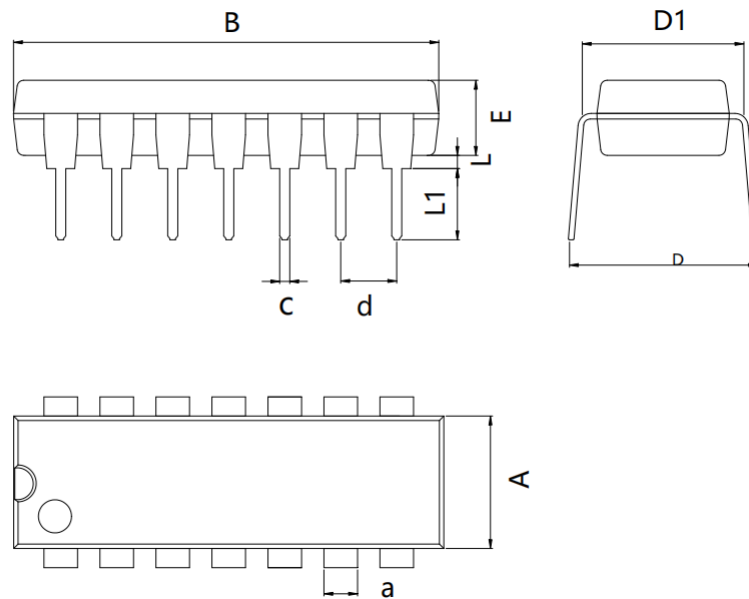

Dimensions In Millimeters (DIP14)										
Symbol:	A	B	D	D1	E	L	L1	a	C	d
Min:	6.10	18.94	8.40	7.42	3.10	0.50	3.00	1.50	0.40	2.54 BSC
Max:	6.68	19.56	9.00	7.82	3.55	0.70	3.60	1.55	0.50	

SOP14

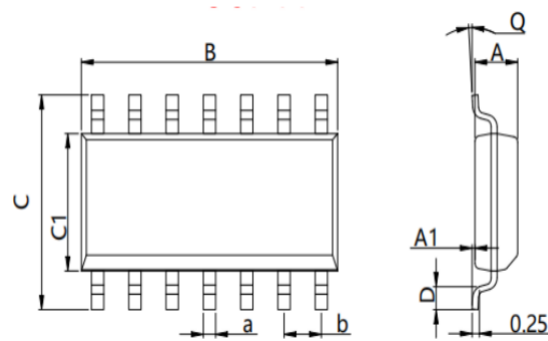

Dimensions In Millimeters (SOP14)									
Symbol:	A	A1	B	C	C1	D	Q	a	b
Min:	1.35	0.05	8.55	5.80	3.80	0.40	0°	0.35	1.27 BSC
Max:	1.55	0.20	8.75	6.20	4.00	0.80	8°	0.45	