

GENERAL PURPOSE SINGLE OPERATIONAL AMPLIFIER

- LARGE INPUT VOLTAGE RANGE
- NO LATCH-UP
- HIGH GAIN
- SHORT-CIRCUIT PROTECTION
- NO FREQUENCY COMPENSATION REQUIRED
- SAME PIN CONFIGURATION AS THE UA709

DESCRIPTION

The UA741 is a high performance monolithic operational amplifier constructed on a single silicon chip. It is intended for a wide range of analog applications.

- Summing amplifier
- Voltage follower
- Integrator
- Active filter
- Function generator

The high gain and wide range of operating voltages provide superior performances in integrator, summing amplifier and general feedback applications. The internal compensation network (6dB/octave) insures stability in closed loop circuits.

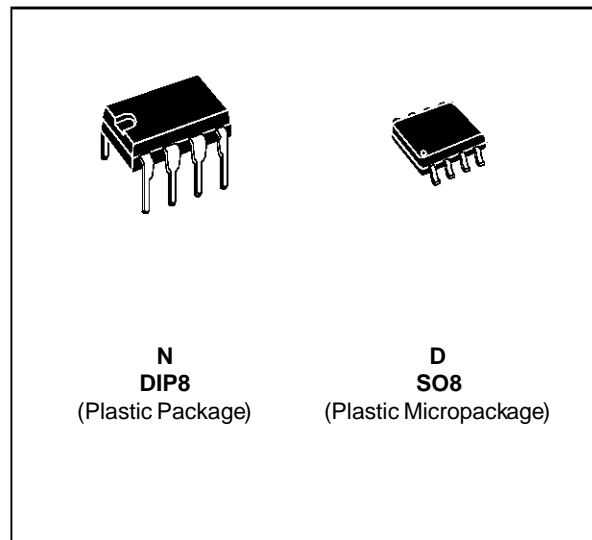

ORDER CODES

Part Number	Temperature Range	Package	
		N	D
	°C, +70°C	•	•
	°C, +105°C	•	•
	°C, +125°C	•	•

Example :

PIN CONNECTIONS (top view)

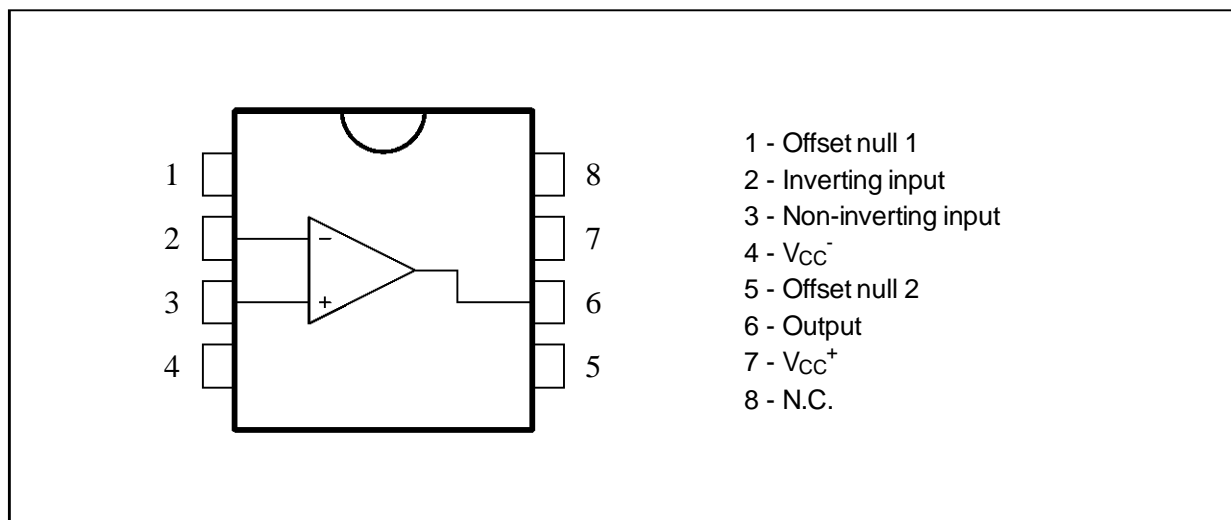

SCHEMATIC DIAGRAM

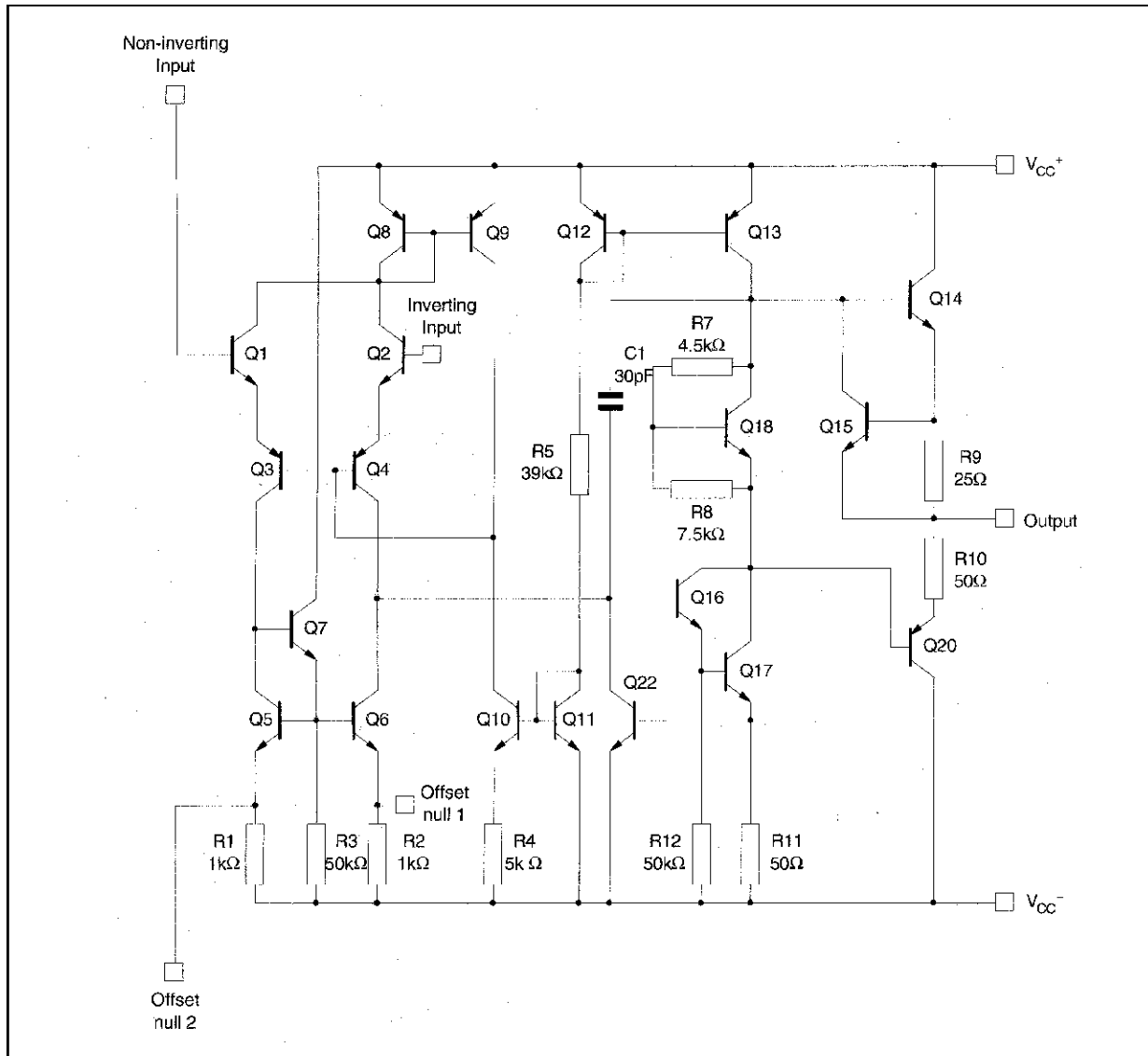

ABSOLUTE MAXIMUM RATINGS

Symbol	Parameter	UA741M	UA741I	UA741C	Unit
V_{CC}	Supply Voltage	±22			V
V_{id}	Differential Input Voltage	±30			V
V_i	Input Voltage	±15			V
P_{tot}	Power Dissipation	500			mW
	Output Short-circuit Duration	Infinite			
T_{oper}	Operating Free Air Temperature Range	-55 to +125	-40 to +105	0 to +70	°C
T_{stg}	Storage Temperature Range	-65 to +150	-65 to +150	-65 to +150	°C

ELECTRICAL CHARACTERISTICS

V_{CC} = ±15V, T_{amb} = +25°C (unless otherwise specified)

Symbol	Parameter	Min.	Typ.	Max.	Unit
V _{io}	Input Offset Voltage (R _S ≤ 10kΩ) T _{amb} = +25°C T _{min.} ≤ T _{amb} ≤ T _{max.}		1	5 6	mV
I _{io}	Input Offset Current T _{amb} = +25°C T _{min.} ≤ T _{amb} ≤ T _{max.}		2	30 70	nA
I _{ib}	Input Bias Current T _{amb} = +25°C T _{min.} ≤ T _{amb} ≤ T _{max.}		10	100 200	nA
A _{vd}	Large Signal Voltage Gain * (V _O ±10V, R _L = 2kΩ) T _{amb} = +25°C T _{min.} ≤ T _{amb} ≤ T _{max.}	50 25	200		V/mV
SVR	Supply Voltage Rejection Ratio (R _S ≤ 10kΩ) T _{amb} = +25°C T _{min.} ≤ T _{amb} ≤ T _{max.}	77 77	90		dB
I _{cc}	Supply Current, no load T _{amb} = +25°C T _{min.} ≤ T _{amb} ≤ T _{max.}		1.7	2.8 3.3	mA
V _{icm}	Input Common Mode Voltage Range T _{amb} = +25°C T _{min.} ≤ T _{amb} ≤ T _{max.}	±12 ±12			V
CMR	Common-mode Rejection Ratio (R _S ≤ 10kΩ) T _{amb} = +25°C T _{min.} ≤ T _{amb} ≤ T _{max.}	70 70	90		dB
I _{os}	Output Short-circuit Current	10	25	40	mA
±V _{OPP}	Output Voltage Swing T _{amb} = +25°C T _{min.} ≤ T _{amb} ≤ T _{max.}				V
	R _L = 10kΩ	12	14		
	R _L = 2kΩ	10	13		
	R _L = 10kΩ	12			
	R _L = 2kΩ	10			
SR	Slew Rate (V _i = ±10V, R _L = 2kΩ, C _L = 100pF, T _{amb} = 25°C, unity gain)	0.25	0.5		V/μs
t _r	Rise Time (V _i = ±20mV, R _L = 2kΩ, C _L = 100pF, T _{amb} = 25°C, unity gain)		0.3		μs
K _{OV}	Overshoot (V _i = 20mV, R _L = 2kΩ, C _L = 100pF, T _{amb} = 25°C, unity gain)		5		%
R _i	Input Resistance	0.3	2		MΩ
GBP	Gain Bandwidth Product (V _i = 10mV, R _L = 2kΩ, C _L = 100pF, f = 100kHz)	0.7	1		MHz
THD	Total Harmonic Distortion (f = 1kHz, A _V = 20dB, R _L = 2kΩ, V _O = 2V _{PP} , C _L = 100pF, T _{amb} = 25°C)		0.06		%
e _n	Equivalent Input Noise Voltage (f = 1kHz, R _S = 100Ω)		23		$\frac{nV}{\sqrt{Hz}}$
∅ _m	Phase Margin		50		Degrees

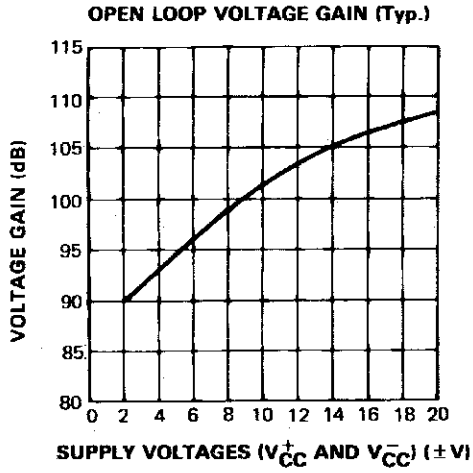

741-04.EPS

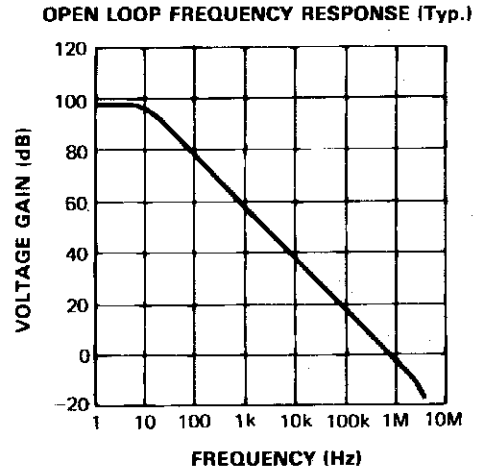

741-05.EP.

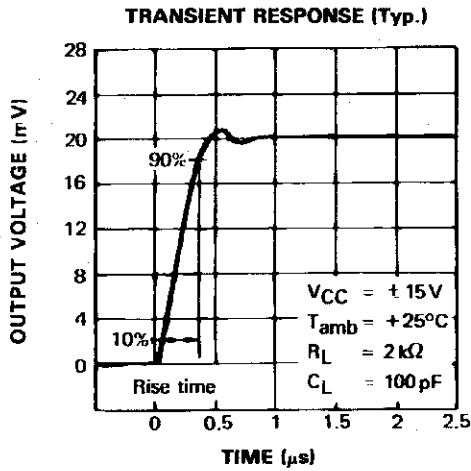

741-06.EPS

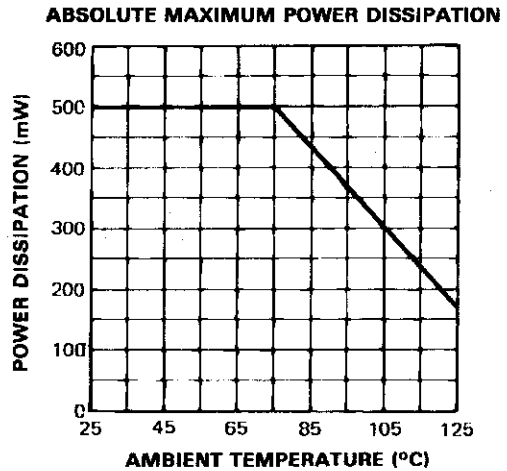

741-07.EPS

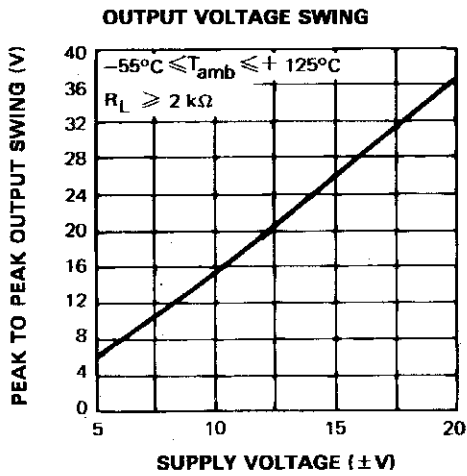

741-08.EPS

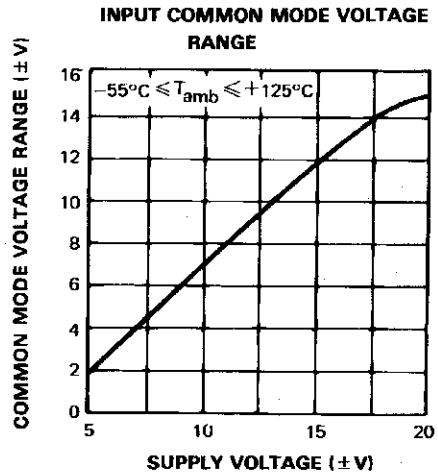

741-09.EPS

POWER CONSUMPTION

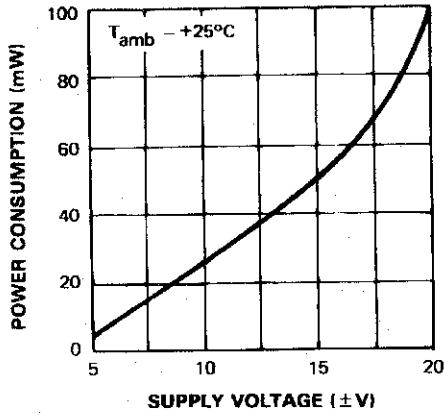

741-10.EPS

OUTPUT CURRENT vs AMBIENT TEMPERATURE

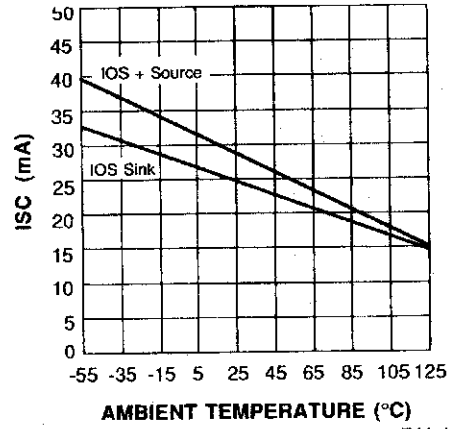

741-11.EPS

OUTPUT VOLTAGE SWING

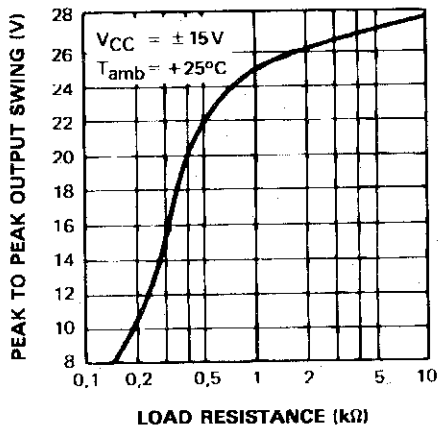

741-12.EPS

OUTPUT VOLTAGE SWING

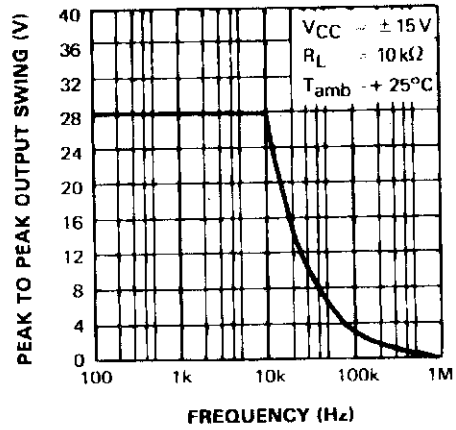

741-13.EPS

EQUIVALENT INPUT NOISE vs FREQUENCY
R_g = 100 Ω

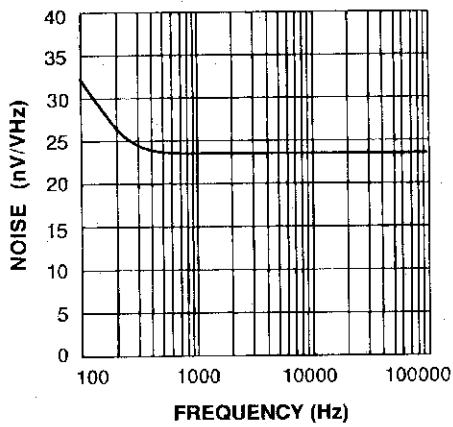

741-14.EPS

INPUT NOISE CURRENT

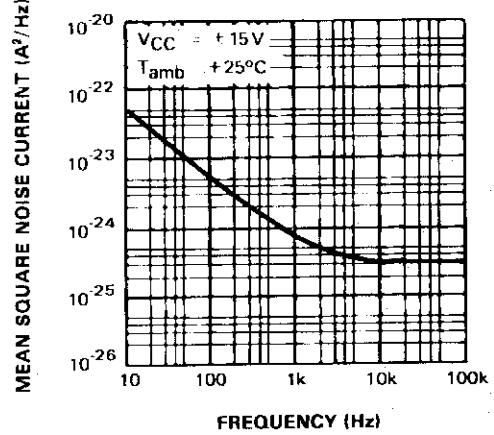

741-15.EPS

EQUIVALENT INPUT NOISE vs AMBIENT TEMPERATURE

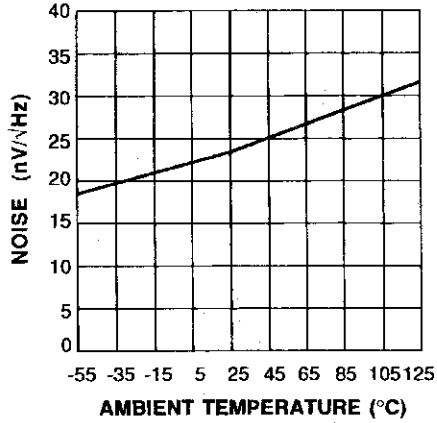

741-16.EPS

LARGE SIGNAL VOLTAGE GAIN vs AMBIENT TEMPERATURE

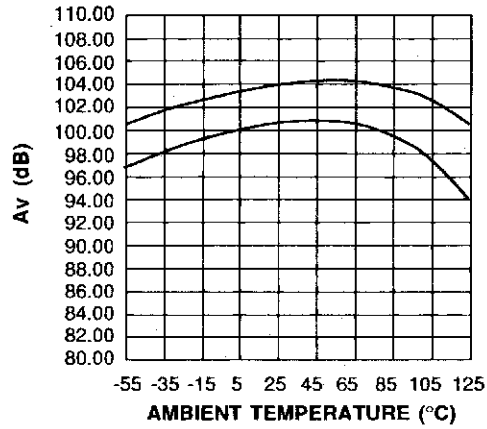

741-17.EPS

GAIN BANDWIDTH PRODUCT vs AMBIENT TEMPERATURE

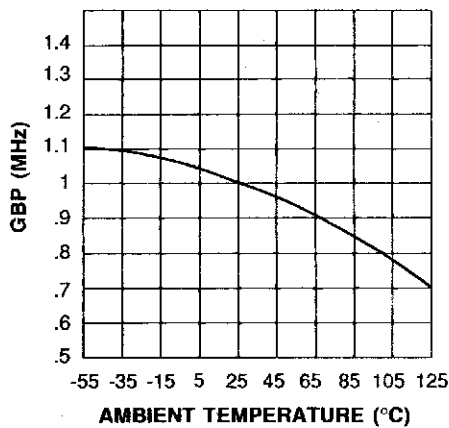

741-18.EPS

POWER SUPPLY & COMMON MODE REJECTION RATIO vs AMBIENT TEMPERATURE

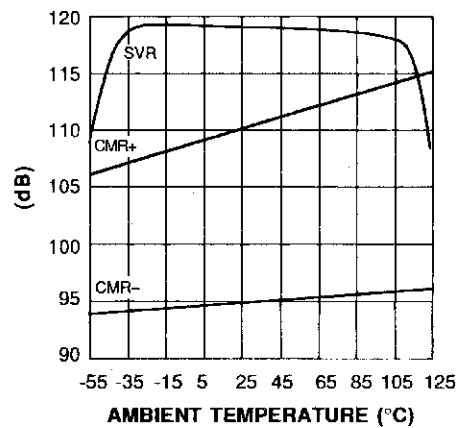

741-19.EPS

INPUT BIAS CURRENT vs AMBIENT TEMPERATURE

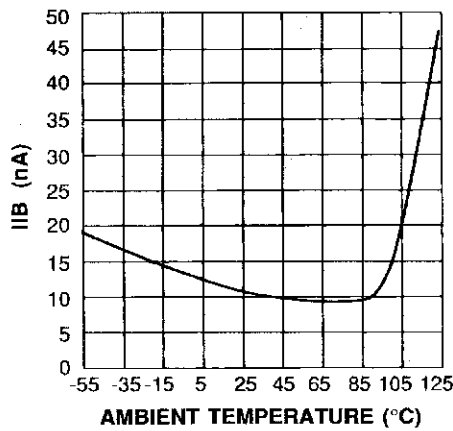

741-20.EPS

MEASUREMENT DIAGRAMS

OFFSET VOLTAGE NULL CIRCUIT

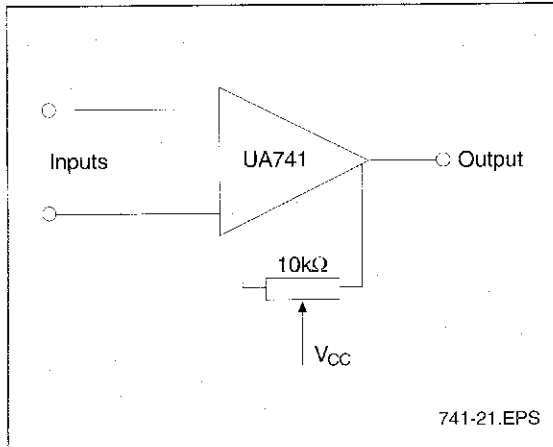

TRANSIENT RESPONSE TEST CIRCUIT

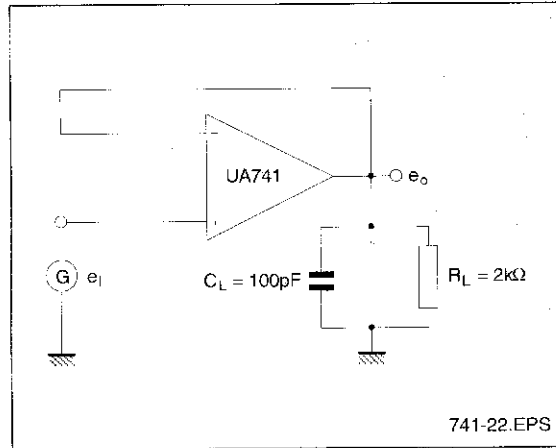

CURRENT TO VOLTAGE CONVERTER

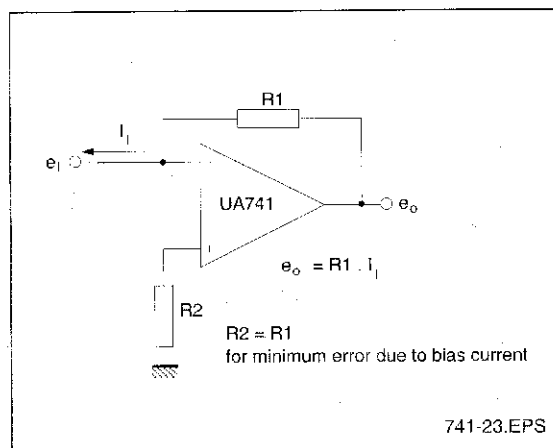

NEUTRALIZING INPUT CAPACITANCE TO OPTIMIZE RESPONSE TIME

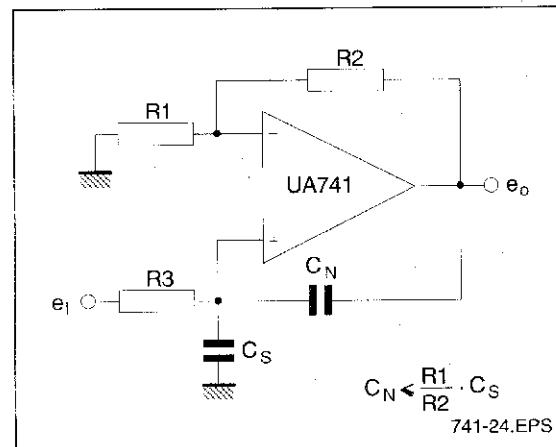

POSITIVE VOLTAGE REFERENCE

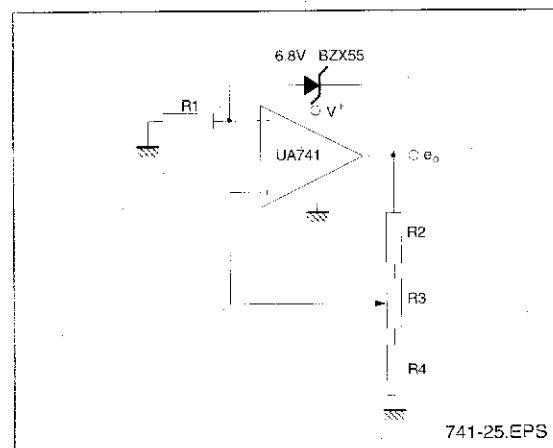

NEGATIVE VOLTAGE REFERENCE

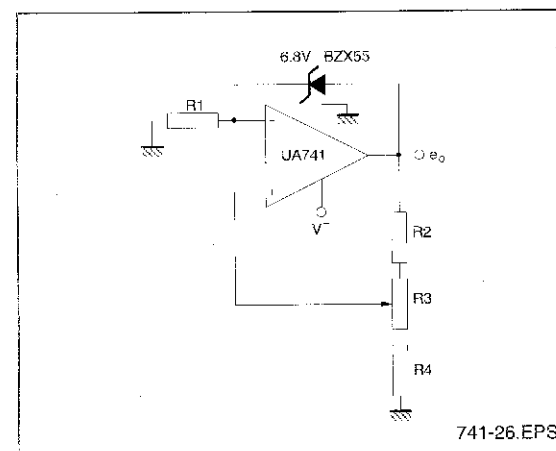

PACKAGE MECHANICAL DATA

8 PINS - PLASTIC DIP

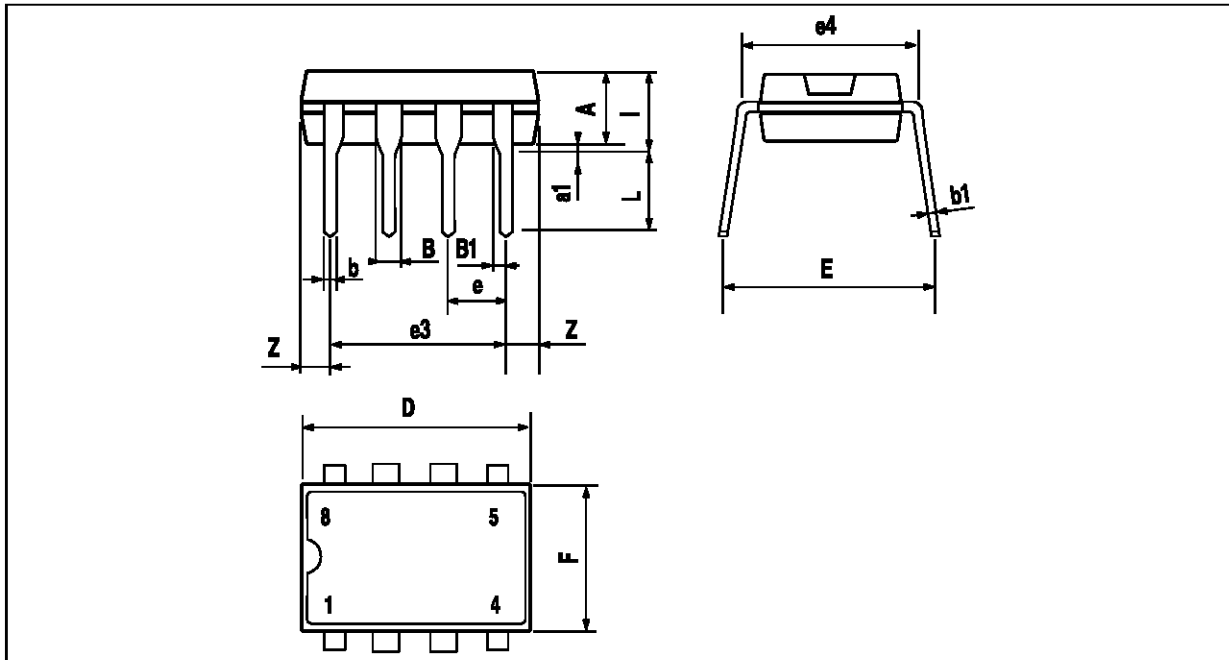

Dim.	Millimeters			Inches		
	Min.	Typ.	Max.	Min.	Typ.	Max.
A		3.32			0.131	
a1	0.51			0.020		
B	1.15		1.65	0.045		0.065
b	0.356		0.55	0.014		0.022
b1	0.204		0.304	0.008		0.012
D			10.92			0.430
E	7.95		9.75	0.313		0.384
e		2.54			0.100	
e3		7.62			0.300	
e4		7.62			0.300	
F			6.6			0.260
i			5.08			0.200
L	3.18		3.81	0.125		0.150
Z			1.52			0.060

PACKAGE MECHANICAL DATA
8 PINS - PLASTIC MICROPACKAGE (SO)

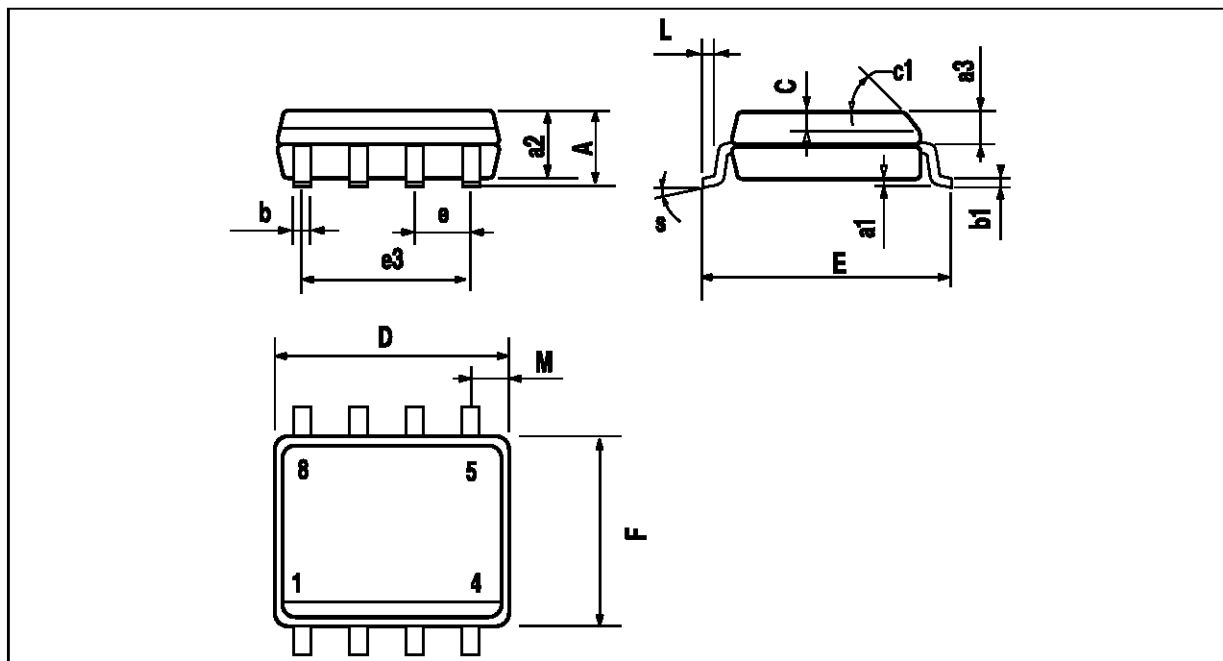

Dim.	Millimeters			Inches		
	Min.	Typ.	Max.	Min.	Typ.	Max.
A			1.75			0.069
a1	0.1		0.25	0.004		0.010
a2			1.65			0.065
a3	0.65		0.85	0.026		0.033
b	0.35		0.48	0.014		0.019
b1	0.19		0.25	0.007		0.010
C	0.25		0.5	0.010		0.020
c1	45° (typ.)					
D	4.8		5.0	0.189		0.197
E	5.8		6.2	0.228		0.244
e		1.27			0.050	
e3		3.81			0.150	
F	3.8		4.0	0.150		0.157
L	0.4		1.27	0.016		0.050
M			0.6			0.024
S	8° (max.)					