

Request For Quotation

Order the parts you need from our real-time inventory database. Simply complete a request for quotation form with your part information and a sales representative will respond to you with price and availability.

[Request For Quotation](#)

Your free datasheet starts on the next page.

More datasheets and data books are available from our homepage: <http://www.datasheetarchive.com>



OPT101

MONOLITHIC PHOTODIODE AND SINGLE-SUPPLY TRANSIMPEDANCE AMPLIFIER

FEATURES

- SINGLE SUPPLY: +2.7 to +36V
- PHOTODIODE SIZE: 0.090 x 0.090 inch
- INTERNAL 1MΩ FEEDBACK RESISTOR
- HIGH RESPONSIVITY: 0.45A/W (650nm)
- BANDWIDTH: 14kHz at R_F = 1MΩ
- LOW QUIESCENT CURRENT: 120μA
- AVAILABLE IN 8-PIN DIP, 5-PIN SIP, AND 8-LEAD SURFACE MOUNT PACKAGES

APPLICATIONS

- MEDICAL INSTRUMENTATION
- LABORATORY INSTRUMENTATION
- POSITION AND PROXIMITY SENSORS
- PHOTOGRAPHIC ANALYZERS
- BARCODE SCANNERS
- SMOKE DETECTORS
- CURRENCY CHANGERS

DESCRIPTION

The OPT101 is a monolithic photodiode with on-chip transimpedance amplifier. Output voltage increases linearly with light intensity. The amplifier is designed for single or dual power supply operation, making it ideal for battery operated equipment.

The integrated combination of photodiode and transimpedance amplifier on a single chip eliminates the problems commonly encountered in discrete designs such as leakage current errors, noise pick-up and gain peaking due to stray capacitance. The 0.09 x 0.09 inch photodiode is operated in the photoconductive mode for excellent linearity and low dark current.

The OPT101 operates from +2.7V to +36V supplies and quiescent current is only 120μA. It is available in clear plastic 8-pin DIP, 5-pin SIP and J-formed DIP for surface mounting. Temperature range is 0°C to 70°C.

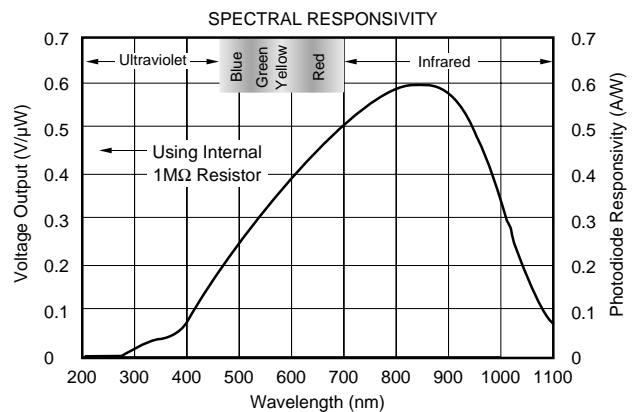
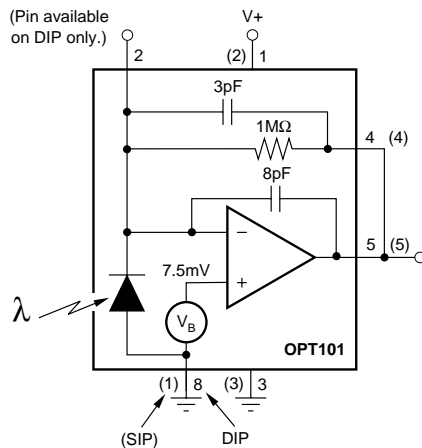

International Airport Industrial Park • Mailing Address: PO Box 11400, Tucson, AZ 85734 • Street Address: 6730 S. Tucson Blvd., Tucson, AZ 85706 • Tel: (520) 746-1111 • Twx: 910-952-1111
Internet: <http://www.burr-brown.com/> • FAXLine: (800) 548-6133 (US/Canada Only) • Cable: BBRCORP • Telex: 066-6491 • FAX: (520) 889-1510 • Immediate Product Info: (800) 548-6132

SPECIFICATIONS

At $T_A = +25^\circ\text{C}$, $V_S = +2.7\text{V}$ to $+36\text{V}$, $\lambda = 650\text{nm}$, internal $1\text{M}\Omega$ feedback resistor, and $R_L = 10\text{k}\Omega$, unless otherwise noted.

PARAMETER	CONDITIONS	OPT101P, W			UNITS
		MIN	TYP	MAX	
RESPONSIVITY					
Photodiode Current	650nm		0.45		A/W
Voltage Output	650nm		0.45		V/ μW
vs Temperature			100		ppm/ $^\circ\text{C}$
Unit to Unit Variation	650nm		± 5		%
Nonlinearity ⁽¹⁾	FS Output = 24V (0.090 x 0.090in)		± 0.01		% of FS
Photodiode Area	(2.29 x 2.29mm)		0.008		in ²
			5.2		mm ²
DARK ERRORS, RTO⁽²⁾					
Offset Voltage, Output		+5	+7.5	+10	mV
vs Temperature			± 2.5		$\mu\text{V}/^\circ\text{C}$
vs Power Supply	$V_S = +2.7\text{V}$ to $+36\text{V}$		10	100	$\mu\text{V}/\text{V}$
Voltage Noise, Dark, $f_B = 0.1\text{Hz}$ to 20kHz	$V_S = +15\text{V}$, $V_{\text{PIN}3} = -15\text{V}$		300		μVrms
TRANSIMPEDANCE GAIN					
Resistor			1		M Ω
Tolerance, P			± 0.5	± 2	%
W			± 0.5		%
vs Temperature			± 50		ppm/ $^\circ\text{C}$
FREQUENCY RESPONSE					
Bandwidth	$V_{\text{OUT}} = 10\text{Vp-p}$		14		kHz
Rise Fall Time, 10% to 90%	$V_{\text{OUT}} = 10\text{V Step}$		28		μs
Settling Time, 0.05%	$V_{\text{OUT}} = 10\text{V Step}$		160		μs
0.1%			80		μs
1%			70		μs
Overload Recovery	100%, Return to Linear Operation		50		μs
OUTPUT					
Voltage Output, High		$(V_S) - 1.3$	$(V_S) - 1.15$		V
Capacitive Load, Stable Operation			10		nF
Short-Circuit Current	$V_S = 36\text{V}$		15		mA
POWER SUPPLY					
Operating Voltage Range		+2.7		+36	V
Quiescent Current	Dark, $V_{\text{PIN}3} = 0\text{V}$ $R_L = \infty$, $V_{\text{OUT}} = 10\text{V}$		120	240	μA
			220		μA
TEMPERATURE RANGE					
Specification		0		+70	$^\circ\text{C}$
Operating		0		+70	$^\circ\text{C}$
Storage		-25		+85	$^\circ\text{C}$
Thermal Resistance, θ_{JA}			100		$^\circ\text{C}/\text{W}$

NOTES: (1) Deviation in percent of full scale from best-fit straight line. (2) Referred to Output. Includes all error sources.

PHOTODIODE SPECIFICATIONS

$T_A = +25^\circ\text{C}$, $V_S = +2.7\text{V}$ to $+36\text{V}$ unless otherwise noted.

PARAMETER	CONDITIONS	Photodiode of OPT101P			UNITS
		MIN	TYP	MAX	
Photodiode Area	(0.090 x 0.090in) (2.29 x 2.29mm)		0.008		in ²
			5.2		mm ²
Current Responsivity	650nm		0.45		A/W
	650nm		865		$\mu\text{A}/\text{cm}^2$
Dark Current	$V_{\text{DIODE}} = 7.5\text{mV}$		2.5		pA
vs Temperature			doubles every 7°C		
Capacitance			1200		pF

The information provided herein is believed to be reliable; however, BURR-BROWN assumes no responsibility for inaccuracies or omissions. BURR-BROWN assumes no responsibility for the use of this information, and all use of such information shall be entirely at the user's own risk. Prices and specifications are subject to change without notice. No patent rights or licenses to any of the circuits described herein are implied or granted to any third party. BURR-BROWN does not authorize or warrant any BURR-BROWN product for use in life support devices and/or systems.

OP AMP SPECIFICATIONS

At $T_A = +25^\circ\text{C}$, $V_S = +2.7\text{V}$ to $+36\text{V}$, $\lambda = 650\text{nm}$, internal $1\text{M}\Omega$ feedback resistor, and $R_L = 10\text{k}\Omega$, unless otherwise noted.

PARAMETER	CONDITIONS	OPT101 Op Amp ⁽¹⁾			UNITS
		MIN	TYP	MAX	
INPUT					
Offset Voltage			± 0.5		mV
vs Temperature			± 2.5		$\mu\text{V}/^\circ\text{C}$
vs Power Supply			10		$\mu\text{V}/\text{V}$
Input Bias Current	(-) Input		165		pA
vs Temperature	(-) Input		1		$\text{pA}/^\circ\text{C}$
Input Impedance					
Differential			$400 \parallel 5$		$\text{M}\Omega \parallel \text{pF}$
Common-Mode			$250 \parallel 35$		$\text{G}\Omega \parallel \text{pF}$
Common-Mode Input Voltage Range	Linear Operation		0 to $[(V_S) - 1]$		V
Common-Mode Rejection			90		dB
OPEN-LOOP GAIN					
Open-loop Voltage Gain			90		dB
FREQUENCY RESPONSE					
Gain-Bandwidth Product ⁽²⁾			2		MHz
Slew Rate			1		$\text{V}/\mu\text{s}$
Settling Time 1%			5.8		μs
0.1%			7.7		μs
0.05%			8.0		μs
OUTPUT					
Voltage Output, High					V
Short-Circuit Current	$V_S = +36\text{V}$	$(V_S) - 1.3$	$(V_S) - 1.15$		mA
			15		
POWER SUPPLY					
Operating Voltage Range		+2.7		+36	V
Quiescent Current	Dark, $V_{\text{PIN}3} = 0\text{V}$ $R_L \infty$, $V_{\text{OUT}} = 10\text{V}$		120	240	μA
			220		μA

NOTES: (1) Op amp specifications provided for information and comparison only. (2) Stable gains $\geq 10\text{V}/\text{V}$.

PIN CONFIGURATIONS

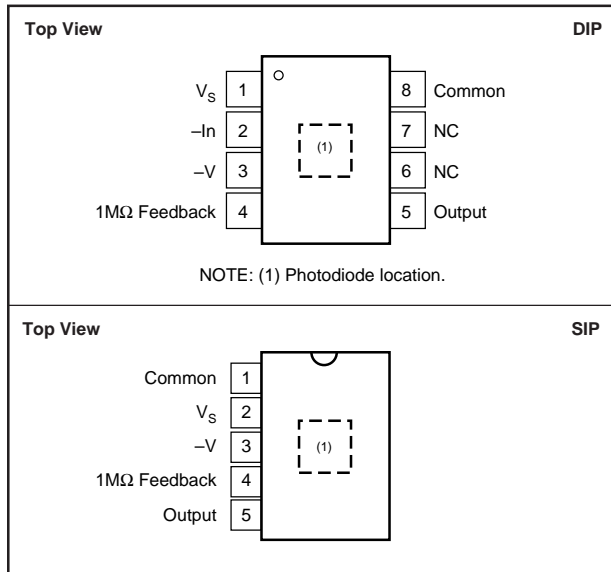

ABSOLUTE MAXIMUM RATINGS

Supply Voltage (V_S to "Common" or pin 3)	0 to +36V
Output Short-Circuit (to ground)	Continuous
Operating Temperature	-25°C to +85°C
Storage Temperature	-25°C to +85°C
Junction Temperature	+85°C
Lead Temperature (soldering, 10s)	+300°C
(Vapor-Phase Soldering Not Recommended)	

PACKAGE INFORMATION

PRODUCT	COLOR	PACKAGE	PACKAGE DRAWING NUMBER ⁽¹⁾
OPT101P	Clear	8-Pin Plastic DIP	006-1
OPT101P-J	Clear	8-Lead Surface Mount ⁽²⁾	006-4
OPT101W	Clear	5-Pin Plastic SIP	321

NOTE: (1) For detailed drawing and dimension table, please see end of data sheet, or Appendix C of Burr-Brown IC Data Book. (2) 8-pin DIP with J-formed leads for surface mounting.



ELECTROSTATIC DISCHARGE SENSITIVITY

This integrated circuit can be damaged by ESD. Burr-Brown recommends that all integrated circuits be handled with appropriate precautions. Failure to observe proper handling and installation procedures can cause damage.

ESD damage can range from subtle performance degradation to complete device failure. Precision integrated circuits may be more susceptible to damage because very small parametric changes could cause the device not to meet its published specifications.



MOISTURE SENSITIVITY AND SOLDERING

Clear plastic does not contain the structural-enhancing fillers used in black plastic molding compound. As a result, clear plastic is more sensitive to environmental stress than black plastic. This can cause difficulties if devices have been stored in high humidity prior to soldering. The rapid heating during soldering can stress wire bonds and cause failures. Prior to soldering, it is recommended that plastic devices be baked-out at +85°C for 24 hours.

The fire-retardant fillers used in black plastic are not compatible with clear molding compound. The OPT101 plastic packages cannot meet flammability test, UL-94.

TYPICAL PERFORMANCE CURVES

At $T_A = +25^\circ\text{C}$, $V_S = +2.7\text{V}$ to $+36\text{V}$, $\lambda = 650\text{nm}$, internal $1\text{M}\Omega$ feedback resistor, and $R_L = 10\text{k}\Omega$, unless otherwise noted.

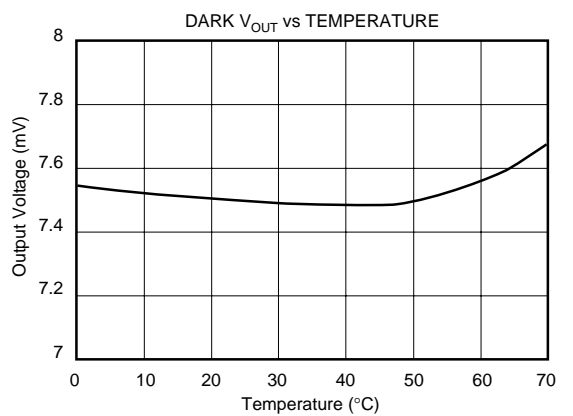
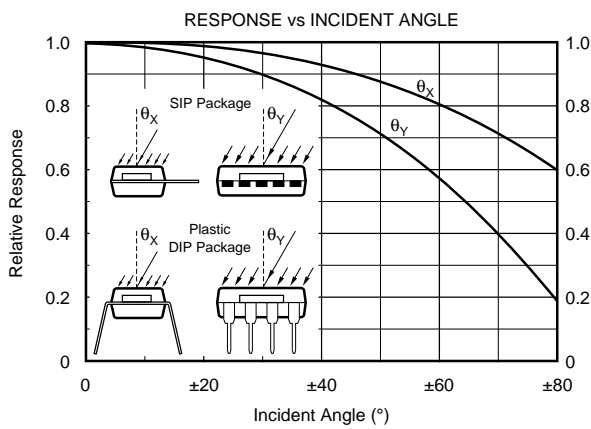
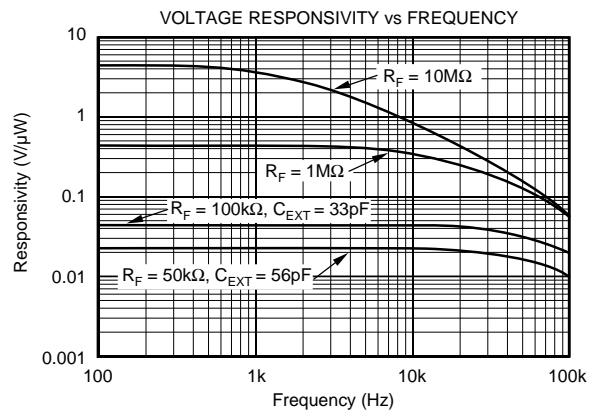
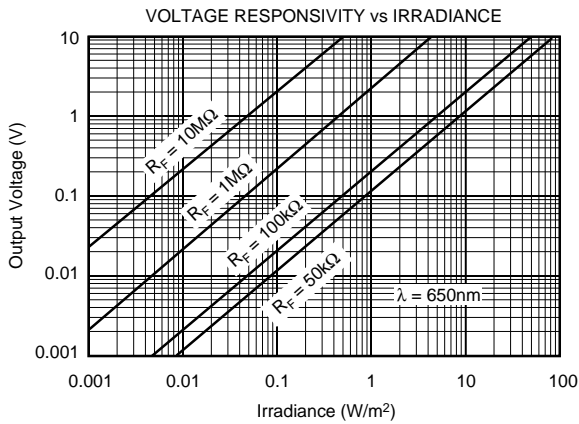
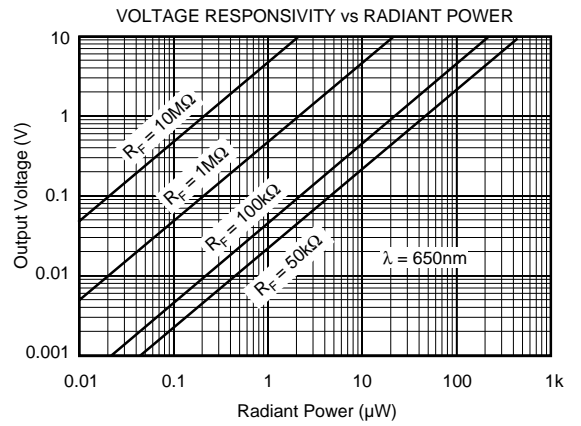
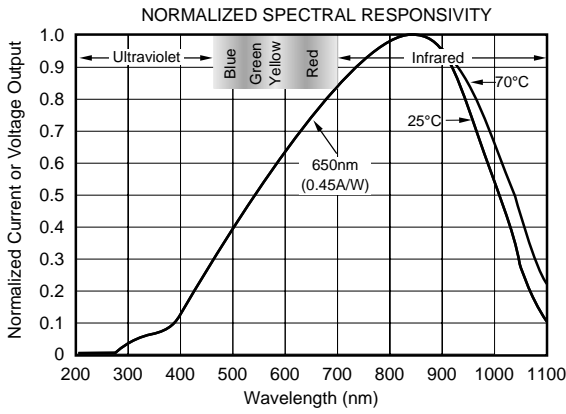

TYPICAL PERFORMANCE CURVES (CONT)

At $T_A = +25^\circ\text{C}$, $V_S = +2.7\text{V}$ to $+36\text{V}$, $\lambda = 650\text{nm}$, internal $1\text{M}\Omega$ feedback resistor, and $R_L = 10\text{k}\Omega$, unless otherwise noted.

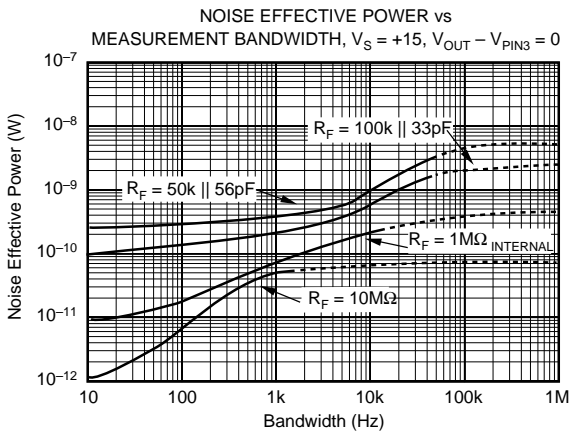
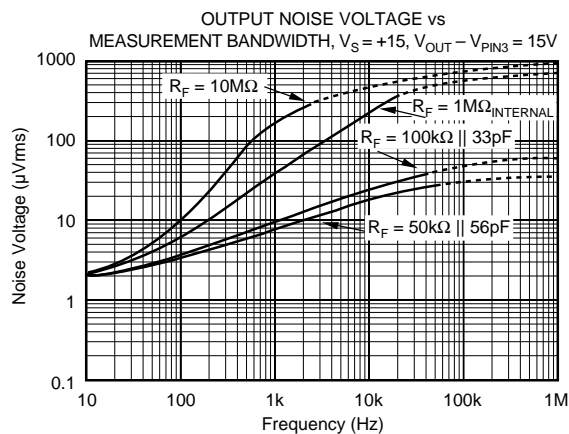
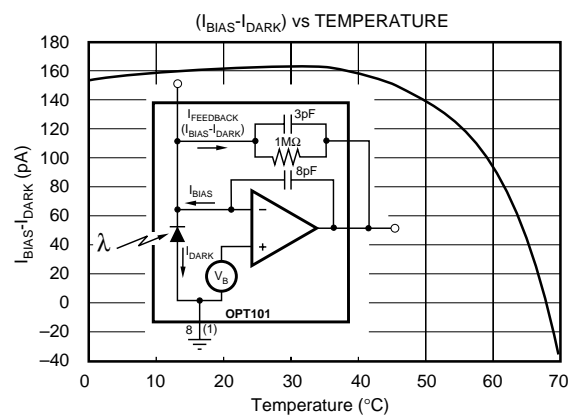
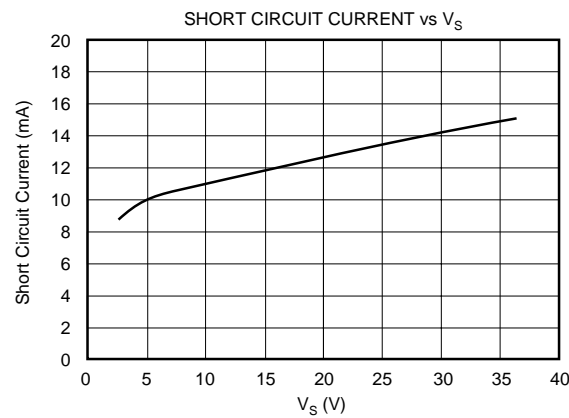
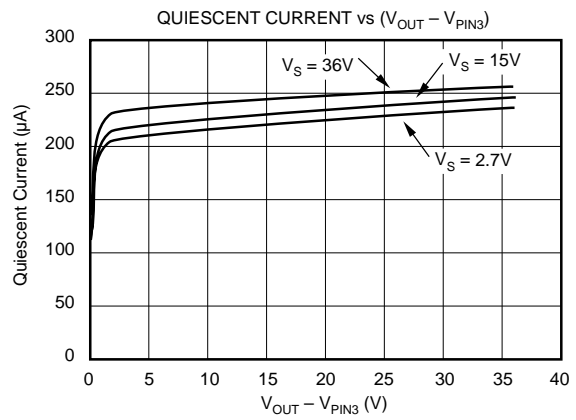
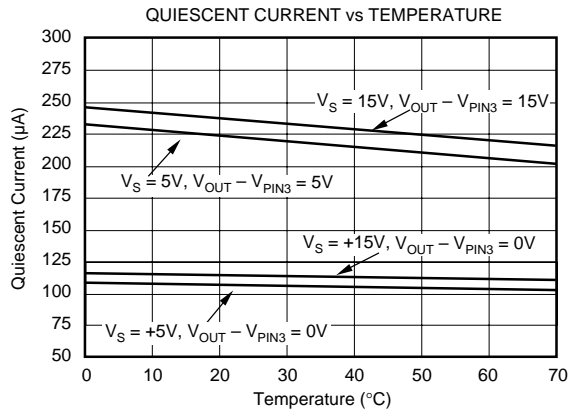

TYPICAL PERFORMANCE CURVES (CONT)

At $T_A = +25^\circ\text{C}$, $V_S = +2.7\text{V}$ to $+36\text{V}$, $\lambda = 650\text{nm}$, internal $1\text{M}\Omega$ feedback resistor, and $R_L = 10\text{k}\Omega$, unless otherwise noted.

SMALL SIGNAL RESPONSE

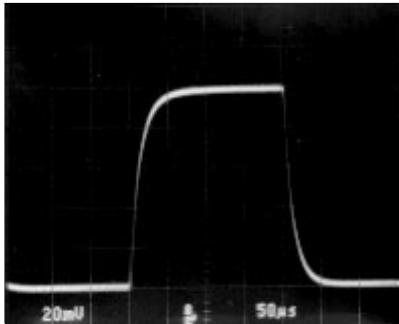

LARGE SIGNAL RESPONSE

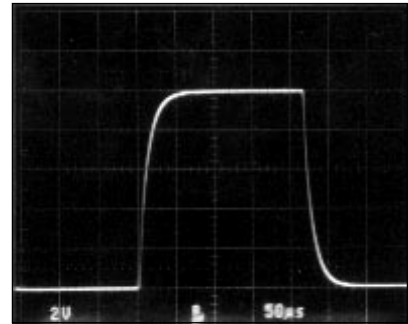

SMALL SIGNAL RESPONSE ($C_{\text{LOAD}} = 10,000\text{ pF}$)
(Pin 3 = 0V)

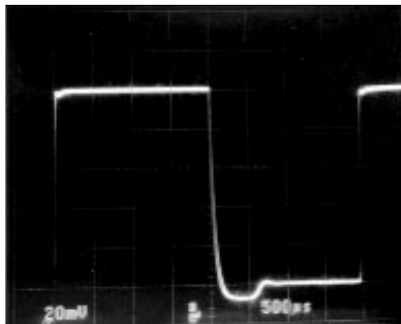

SMALL SIGNAL RESPONSE ($C_{\text{LOAD}} = 10,000\text{ pF}$)
(Pin 3 = -15V)

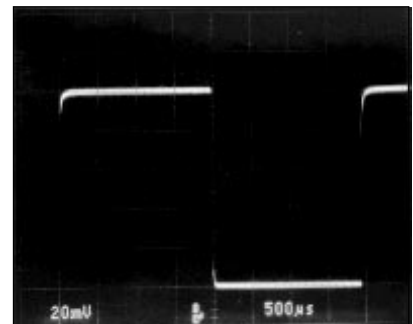

APPLICATIONS INFORMATION

Figure 1 shows the basic connections required to operate the OPT101. Applications with high-impedance power supplies may require decoupling capacitors located close to the device pins as shown. Output is 7.5mV dc with no light and increases with increasing illumination.

Photodiode current, I_D , is proportional to the radiant power, or flux, (in watts) falling on the photodiode. At a wavelength of 650nm (visible red) the photodiode Responsivity, R_P , is approximately 0.45A/W. Responsivity at other wavelengths is shown in the typical performance curve "Responsivity vs Wavelength."

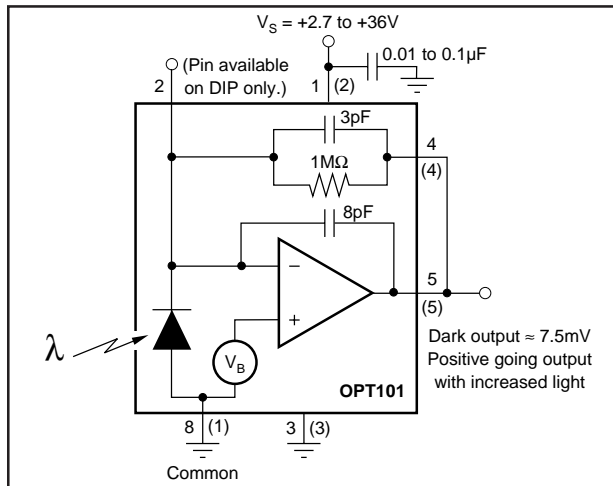

FIGURE 1. Basic Circuit Connections.

The typical performance curve "Output Voltage vs Radiant Power" shows the response throughout a wide range of radiant power. The response curve "Output Voltage vs Irradiance" is based on the photodiode area of 5.2mm².

The OPT101's voltage output is the product of the photodiode current times the feedback resistor, ($I_D R_F$), plus a pedestal voltage, V_B , of approximately 7.5mV introduced for single supply operation. The internal feedback resistor is laser trimmed to 1MΩ. Using this resistor, the output voltage responsivity, R_V , is approximately 0.45V/μW at 650nm wavelength. Figure 1 shows the basic circuit connections for the OPT101 operating with a single power supply and using the internal 1MΩ feedback resistor for a response of 0.45V/μW at 650nm. Pin 3 is connected to common in this configuration.

CAPACITIVE LOADING

The OPT101 is capable of driving load capacitances of 10nF without instability. However, dynamic performance with capacitive loads can be improved by applying a negative bias voltage to Pin 3 (shown in Figure 2). This negative power supply voltage allows the output to go negative in response to the reactive effect of a capacitive load. An internal JFET connected between pin 5 (output) and pin 3 allows the output to sink current. This current sink capability can also be useful when driving the capacitive inputs of some analog-to-digital converters which require the signal

source to sink currents up to approximately 100μA. The benefits of this current sink are shown in the typical performance curves "Small Signal Response ($C_{LOAD} = 10,000pF$)" which compare operation with pin 3 grounded and connected to -15V.

Due to the architecture of this output stage current sink, there is a slight increase in operating current when there is a voltage between pin 3 and the output. Depending on the magnitude of this voltage, the quiescent current will increase by approximately 100μA as shown in the typical performance curve "Quiescent Current vs ($V_{OUT} - V_{PIN3}$)".

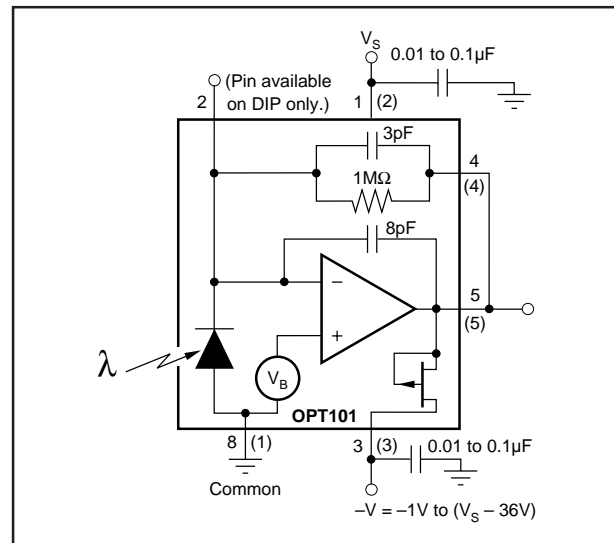

FIGURE 2. Bipolar Power Supply Circuit Connections.

NOISE PERFORMANCE

Noise performance of the OPT101 is determined by the op amp characteristics, feedback components and photodiode capacitance. The typical performance curve "Output Noise Voltage vs Measurement Bandwidth" shows how the noise varies with R_F and measured bandwidth (0.1Hz to the indicated frequency), when the output voltage minus the voltage on pin 3 is greater than approximately 50mV. Below this level, the output stage is powered down, and the effective bandwidth is decreased. This reduces the noise to approximately 1/3 the nominal noise value of 300μVrms, or 100μVrms. This enables a low level signal to be resolved.

Noise can be reduced by filtering the output with a cutoff frequency equal to the signal bandwidth. This will improve signal-to-noise ratio. Also, output noise increases in proportion to the square root of the feedback resistance, while responsivity increases linearly with feedback resistance. Best signal-to-noise ratio is achieved with large feedback resistance. This comes with the trade-off of decreased bandwidth.

The noise performance of the photodetector is sometimes characterized by *Noise Effective Power* (NEP). This is the radiant power that would produce an output signal equal to the noise level. NEP has the units of radiant power (watts), or Watts/√Hz to convey spectral information about the noise. The typical performance curve "Noise Effective Power" vs Measurement Bandwidth" illustrates the NEP for the OPT101.

DARK ERRORS

The dark errors in the specification table include all sources. The dominant source of dark output voltage is the “pedestal” voltage applied to the non-inverting input of the op amp. This voltage is introduced to provide linear operation in the absence of light falling on the photodiode. Photodiode dark current is approximately 2.5pA and contributes virtually no offset error at room temperature. The bias current of the op amp's summing junction (– input) is approximately 165pA. The dark current will be subtracted from the amplifier's bias current, and this residual current will flow through the feedback resistor creating an offset. The effects of temperature on this difference current can be seen in the typical performance curve “($I_{BIAS} - I_{DARK}$) vs Temperature.” The dark output voltage can be trimmed to zero with the optional circuit shown in Figure 3. A low impedance offset driver (op amp) should be used to drive pin 8 (DIP) because this node has signal-dependent currents.

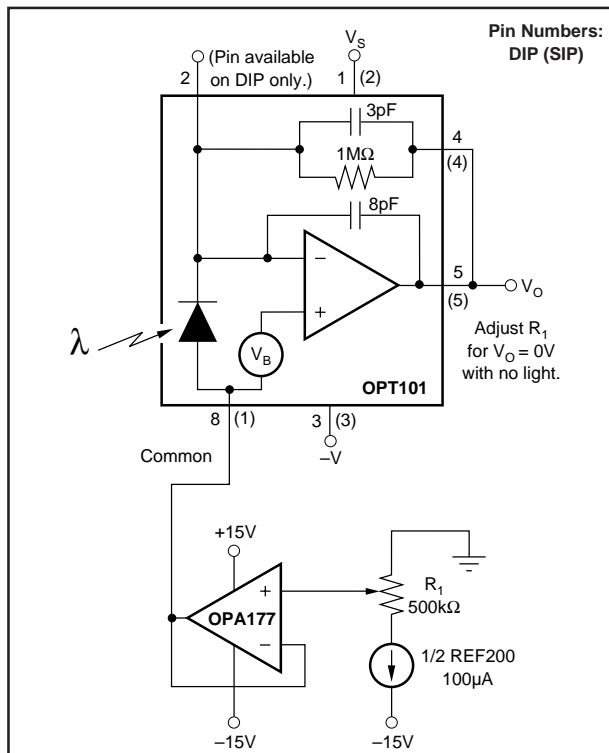

FIGURE 3. Dark Error (Offset) Adjustment Circuit.

CHANGING RESPONSIVITY

An external resistor, R_{EXT} , can be connected to set a different voltage responsivity. To increase the responsivity, this resistor can be placed in series with the internal 1MΩ (Figure 4a), or with the DIP package, the external resistor can replace the internal resistor by not connecting pin 4 (Figure 4b). The second configuration also allows the circuit gain to be reduced below 10⁶V/A by using external resistors of less than 1MΩ.

Figure 4 includes tables showing the responsivity and bandwidth. For values of R_F less than 1MΩ, an external capacitor, C_{EXT} should be connected in parallel with R_F .

This capacitor eliminates gain peaking and prevents instability. The value of C_{EXT} can be determined from the table in Figure 4. Values of R_F , other than shown in the table, can be interpolated.

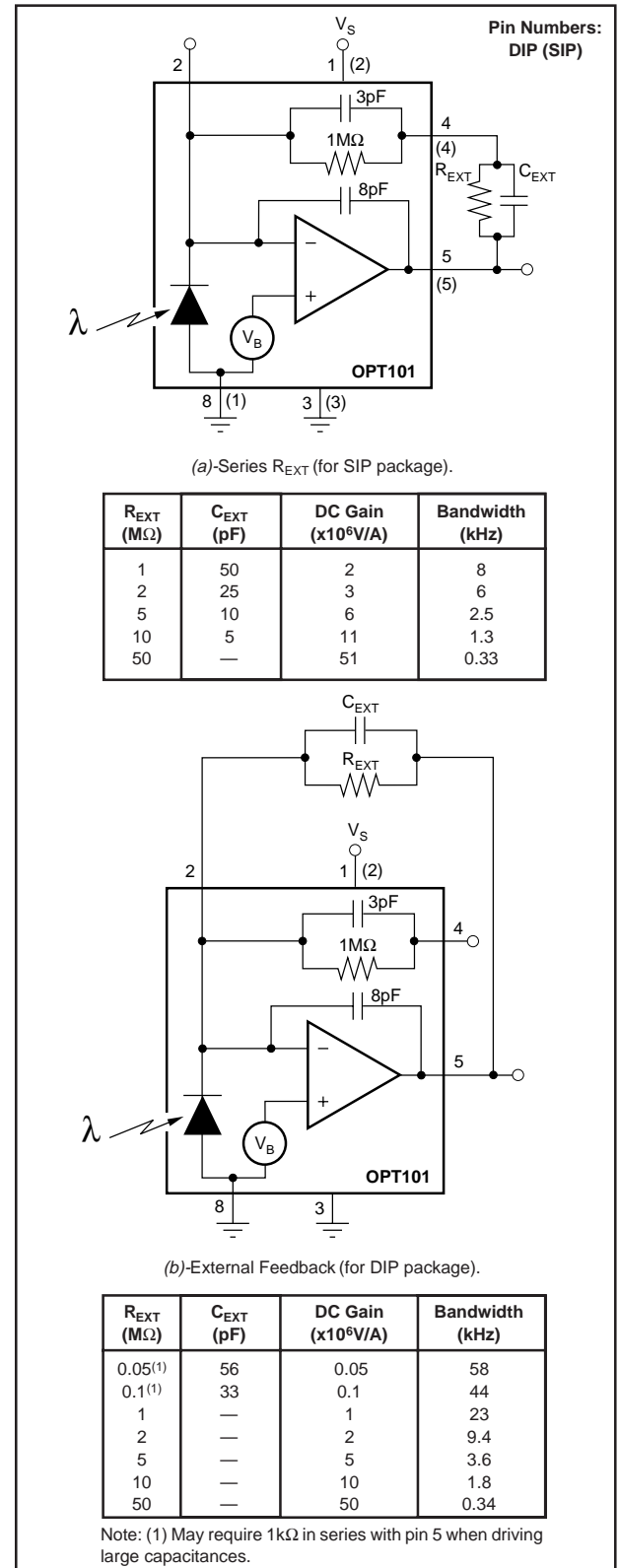

FIGURE 4. Changing Responsivity with External Resistor.

LIGHT SOURCE POSITIONING

The OPT101 is tested with a light source that uniformly illuminates the full area of the integrated circuit, including the op amp. Although IC amplifiers are light-sensitive to some degree, the OPT101 op amp circuitry is designed to minimize this effect. Sensitive junctions are shielded with metal, and the photodiode area is very large relative to the op amp input circuitry.

If your light source is focused to a small area, be sure that it is properly aimed to fall on the photodiode. A narrowly focused beam falling on only the photodiode will provide improved settling times compared to a source that uniformly illuminates the full area of the die. If a narrowly focused light source were to miss the photodiode area and fall only on the op amp circuitry, the OPT101 would not perform properly. The large 0.09" x 0.09" (2.29mm x 2.29mm) photodiode area allows easy positioning of narrowly focused light sources. The photodiode area is easily visible, as it appears very dark compared to the surrounding active circuitry.

The incident angle of the light source also effects the apparent sensitivity in uniform irradiance. For small incident angles, the loss in sensitivity is simply due to the smaller effective light gathering area of the photodiode (proportional to the cosine of the angle). At a greater incident angle, light is diffracted and scattered by the package. These effects are shown in the typical performance curve "Responsivity vs Incident Angle."

DYNAMIC RESPONSE

Using the internal 1MΩ resistor, the dynamic response of the photodiode/op amp combination can be modeled as a simple R • C circuit with a -3dB cutoff frequency of

approximately 14kHz. The R and C values are 1MΩ and 1pF respectively. By using external resistors, with less than 3pF parasitic capacitance, the frequency response can be improved. An external 1MΩ resistor used in the configuration shown in Figure 4b will create a 23kHz bandwidth with the same 10⁶V/A dc transimpedance gain. This yields a rise time of approximately 15μs (10% to 90%). Dynamic response is not limited by op amp slew rate. This is demonstrated by the dynamic response oscilloscope photographs showing virtually identical large-signal and small-signal response.

Dynamic response will vary with feedback resistor value as shown in the typical performance curve "Responsivity vs Frequency." Rise time (10% to 90%) will vary according to the -3dB bandwidth produced by a given feedback resistor value:

$$t_r = \frac{0.35}{f_c}$$

where:

t_r is the rise time (10% to 90%)

f_c is the -3dB bandwidth

LINEARITY PERFORMANCE

The photodiode is operated in the photoconductive mode so the current output of the photodiode is very linear with radiant power throughout a wide range. Nonlinearity remains below approximately 0.05% up to 100μA photodiode current. The photodiode can produce output currents of 1mA or greater with high radiant power, but nonlinearity increases to several percent in this region.

This very linear performance at high radiant power assumes that the full photodiode area is uniformly illuminated. If the light source is focused to a small area of the photodiode, nonlinearity will occur at lower radiant power.

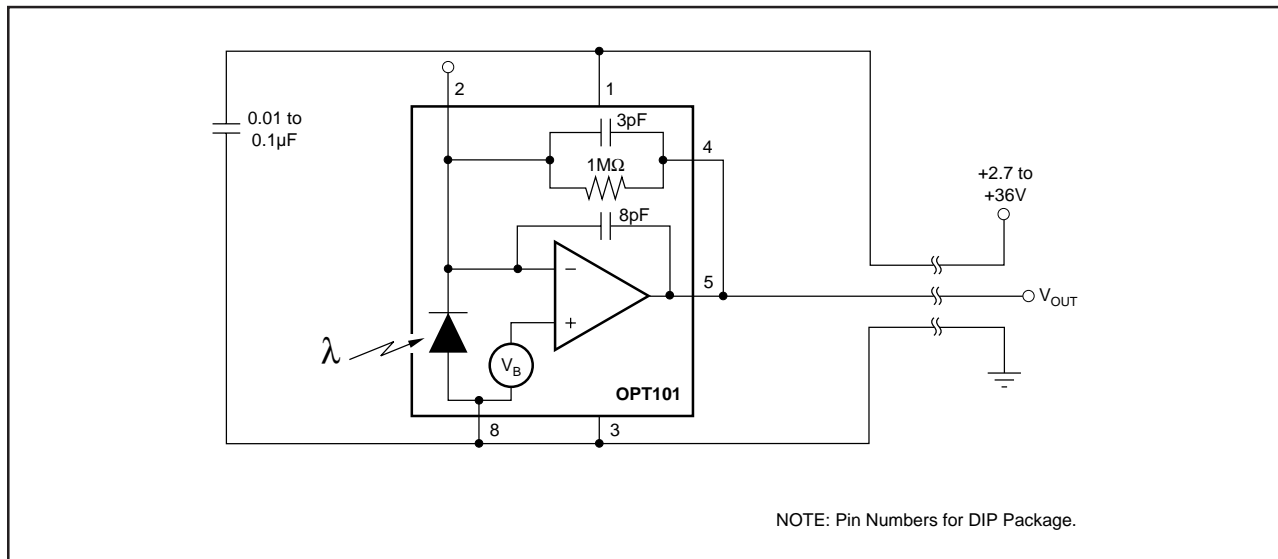

FIGURE 5. Three-Wire Remote Light Measurement.

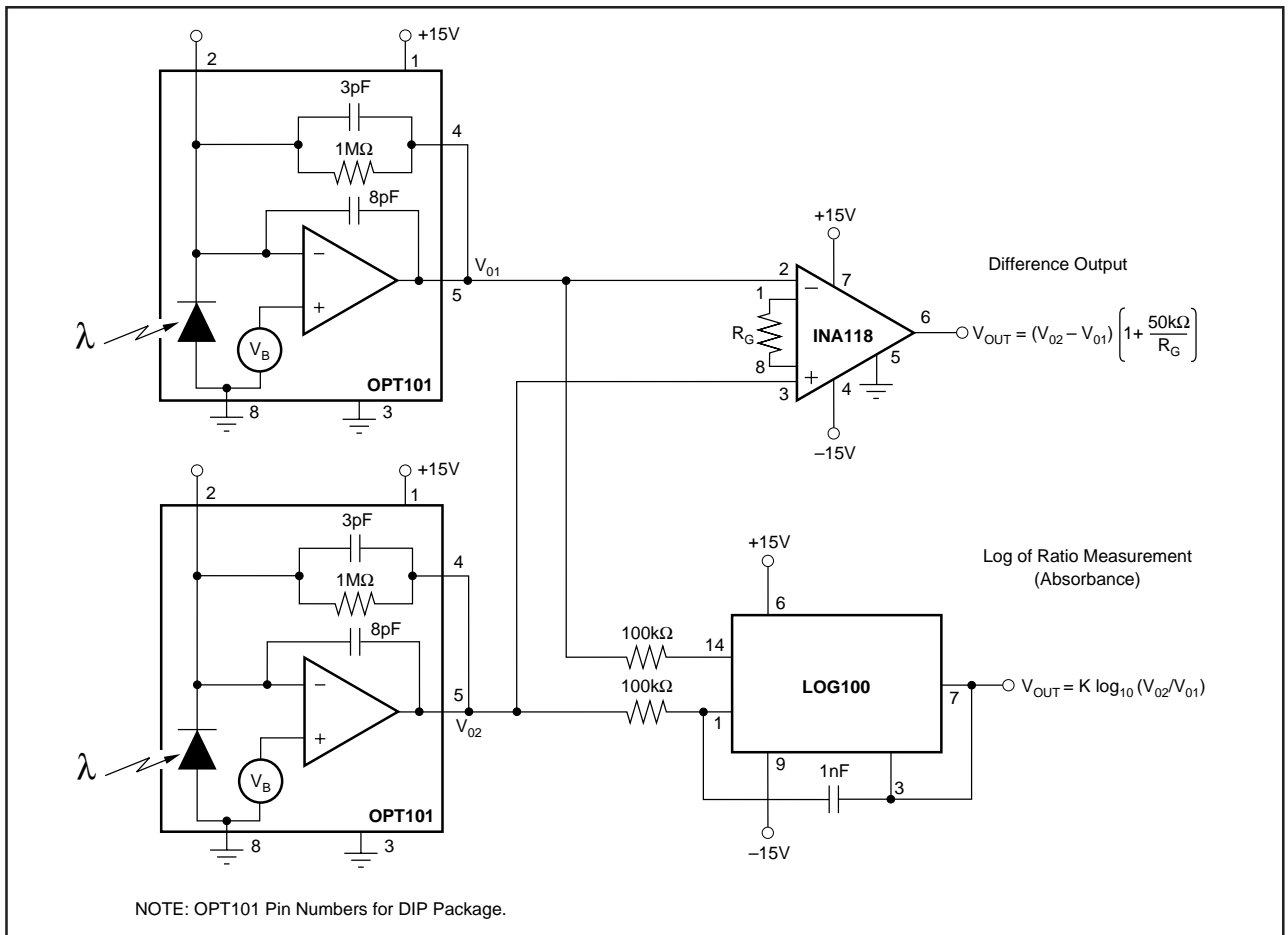

FIGURE 6. Differential Light Measurement.

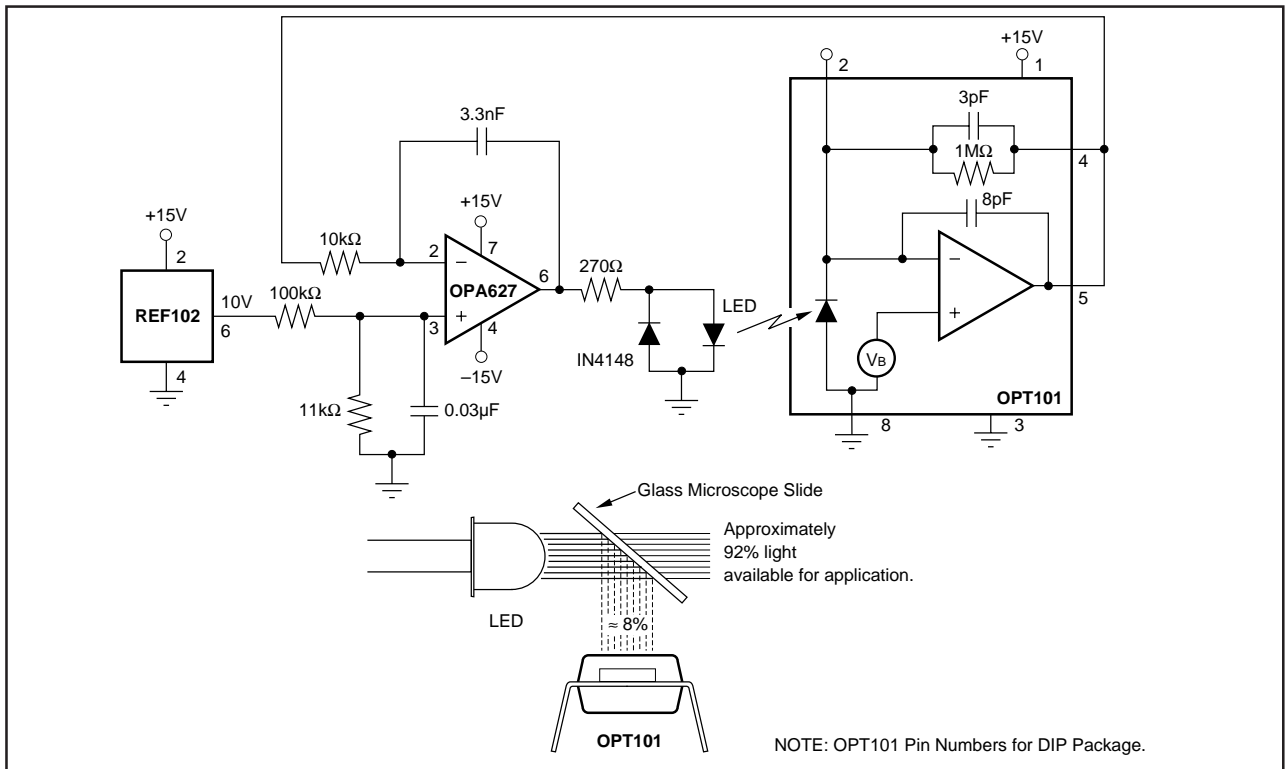

FIGURE 7. LED Output Regulation Circuit.

IMPORTANT NOTICE

Texas Instruments and its subsidiaries (TI) reserve the right to make changes to their products or to discontinue any product or service without notice, and advise customers to obtain the latest version of relevant information to verify, before placing orders, that information being relied on is current and complete. All products are sold subject to the terms and conditions of sale supplied at the time of order acknowledgment, including those pertaining to warranty, patent infringement, and limitation of liability.

TI warrants performance of its semiconductor products to the specifications applicable at the time of sale in accordance with TI's standard warranty. Testing and other quality control techniques are utilized to the extent TI deems necessary to support this warranty. Specific testing of all parameters of each device is not necessarily performed, except those mandated by government requirements.

Customers are responsible for their applications using TI components.

In order to minimize risks associated with the customer's applications, adequate design and operating safeguards must be provided by the customer to minimize inherent or procedural hazards.

TI assumes no liability for applications assistance or customer product design. TI does not warrant or represent that any license, either express or implied, is granted under any patent right, copyright, mask work right, or other intellectual property right of TI covering or relating to any combination, machine, or process in which such semiconductor products or services might be or are used. TI's publication of information regarding any third party's products or services does not constitute TI's approval, warranty or endorsement thereof.