



YETDA INDUSTRY LTD.

3mm Pink Super Bright LED Lamps S300TP4G

3mm with InGaN Dice ◦

Encapsulated with Water Clear Lens Package ◦

Long Leads ◦

Absolute Maximum Ratings :

Parameter	Maximum Rating	Unit
Peak Forward Current	120	mA
Continuous Forward Current	30	mA
Operating Temperature Range	-40°C to +85°C	
Storage Temperature Range	-50°C to +100°C	
Lead Soldering Temperature	260°C for 3 seconds 1.6mm(0.063 inch) from body	

Electro-Optical Characteristics (Ta = 25°C)

Parameter	Test Condition	Symbol	Min.	Typ.	Max.	Unit
Forward Voltage	IF = 20mA	Vf		3.2	3.8	V
Reverse Current	VR = 5V	Ir			10	uA
Luminous Intensity	IF = 20mA	Iv	300	500		mcd
Spectral Bandwidth	IF = 20mA	$\Delta\lambda$				nm
Wavelength	IF = 20mA	X		0.45		
	IF = 20mA	Y		0.15		
Viewing Angle	IF = 20mA	2 θ 1/2		20		deg

Please refer to CIE1931 Chromaticity Coordinate diagram

Package

Item:300

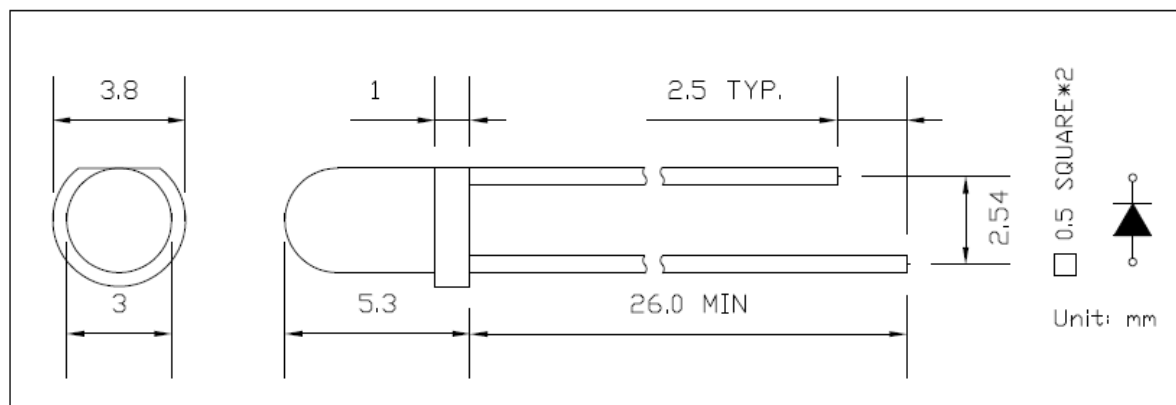



YETDA INDUSTRY LTD.

•Soldering:

1. Manual of soldering

The temperature of the iron tip should not be higher than 260 °C and

Soldering within 3 seconds per solder-land is to be observed

2. DIP soldering (Wave Soldering):

Preheating: 120 °C ~ 150°C within 5 sec. 260°C (Max)

Gradual Cooling (Avoid quenching)

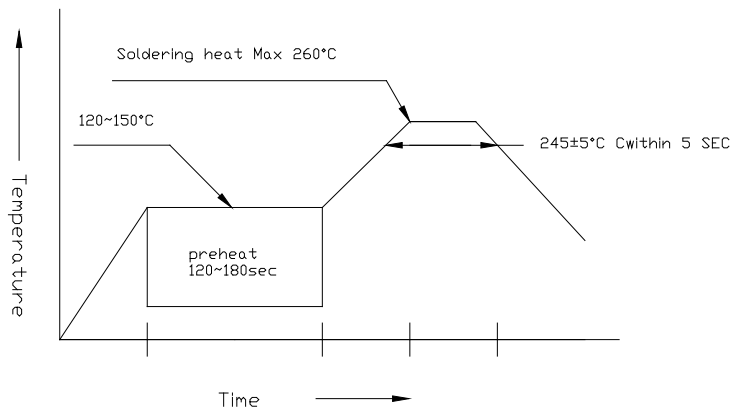

3. Reflow Soldering

Preheating: 140 °C ~ 160°C ±5°C, within 2 minutes.

Operation heating: 235 °C (Max) within 10 seconds (Max)

Gradual Cooling (Avoid quenching)

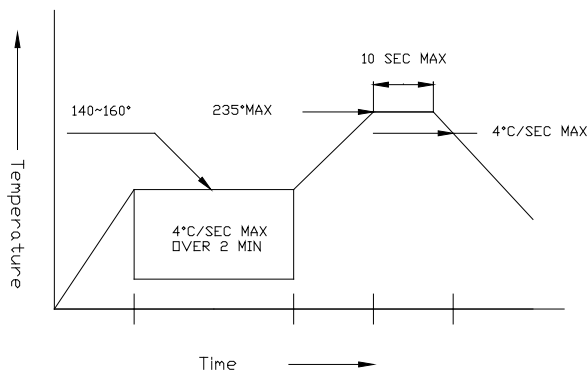

•Handling:

Care must be taken not to cause to the epoxy resin portion of Yetda LEDS while it is exposed to high temperature.

Care must be taken not rub the epoxy resin portion of Yetda LEDS with hard or sharp article such as the sand blast and the metal hook