



# PIC16(L)F1764/5/8/9

## 14/20-Pin, 8-Bit Flash Microcontrollers

### Description

The PIC16(L)F1764/5/8/9 family offers intelligent analog with digital peripherals to create up to two independent closed-loop channels. These 14 and 20-pin devices enable the ability to interconnect the on-chip peripherals to create custom functions specific to each application; helping simplify the implementation of a complex control system and give designers the flexibility to innovate.

### Core Features

- C Compiler Optimized RISC Architecture
- Only 49 Instructions
- Operating Speed:
  - DC – 32 MHz clock input
  - 125 ns minimum instruction cycle
- Interrupt Capability
- 16-Level Deep Hardware Stack
- Up to Four 8-Bit Timers
- Up to Three 16-Bit Timers
- Power-on Reset (POR)
- Configurable Power-up Timer (PWRT)
- Brown-out Reset (BOR) with Selectable Trip Point
- Extended Watchdog Timer (EWDT):
  - Low-power 31 kHz WDT
  - Software-selectable prescaler
  - Software-selectable enable

### Memory

- Up to 14 Kbytes Flash Program Memory
- Up to 1024 Bytes Data RAM Memory
- Direct, Indirect and Relative Addressing modes
- High-Endurance Flash (HEF):
  - 128B of nonvolatile data storage
  - 100K erase/write cycles

### Operating Characteristics

- Operating Voltage Range:
  - 1.8V to 3.6V (PIC16LF1764/5/8/9)
  - 2.3V to 5.5V (PIC16F1764/5/8/9)
- Temperature Range:
  - Industrial: -40°C to +85°C
  - Extended: -40°C to +125°C

### eXtreme Low-Power (XLP) Features

- Sleep mode: 50 nA @ 1.8V, typical
- Watchdog Timer: 500 nA @ 1.8V, typical
- Secondary Oscillator: 500 nA @ 32 kHz
- Operating Current:
  - 8  $\mu$ A @ 32 kHz, 1.8V, typical
  - 32  $\mu$ A/MHz @ 1.8V, typical
- Low-Power BOR (LPBOR):
  - 200 nA in Sleep

### Digital Peripherals

- Configurable Logic Cell (CLC):
  - Up to three CLCs; up to four selected inputs
  - Integrated combinational and state logic
- Up to Two Complementary Output Generators (COG):
  - Push-Pull, Full-Bridge and Steering modes
- Up to Two Capture/Compare/PWM (CCP) modules
- Pulse-Width Modulators (PWM):
  - Up to two 10-bit PWMs
  - Up to two 16-bit PWMs
- Peripheral Pin Select (PPS):
  - Configure any digital pin to output
- Serial Communications:
  - Enhanced USART (EUSART)
  - SPI, I<sup>2</sup>C, RS-232, RS-485, LIN compatible
  - Auto-Baud Detect, auto-wake-up on start
- Up to 18 I/O Pins:
  - Individually programmable pull-ups
  - Slew rate control
  - Interrupt-On-Change (IOC) with edge select
- Up to Two Data Signal Modulators (DSM)

### Intelligent Analog Peripherals

- 10-Bit Analog-to-Digital Converter (ADC):
  - Up to 12 external channels
  - Conversion available during Sleep
- Up to Two Operational Amplifiers (OPA):
  - Selectable internal and external channels
- Up to Four Fast Comparators (COMP):
  - Up to five external inverting inputs
  - Up to eight external noninverting inputs
  - Fixed Voltage Reference at noninverting input(s)
  - Comparator outputs externally accessible
- Digital-to-Analog Converters (DAC):
  - Up to two 10-bit resolution DACs
  - Up to two 5-bit resolution DACs

# PIC16(L)F1764/5/8/9

## Intelligent Analog Peripherals (Cont.)

- Voltage Reference:
  - Fixed Voltage Reference (FVR): 1.024V, 2.048V and 4.096V output levels
- Zero-Cross Detector (ZCD):
  - Detect high-voltage AC signal
- Programmable Ramp Generator (PRG):
  - Slope compensation
  - Ramp generation
- High-Current Drive I/Os:
  - 100 mA capacity @ 5V

## Clocking Structure

- 16 MHz Internal Oscillator:
  - $\pm 1\%$  at calibration
  - Selectable frequency range, 32 MHz to 31 kHz
- 31 kHz Low-Power Internal Oscillator
- 4x Phase-Locked Loop (PLL):
  - For up to 32 MHz internal operation
- External Oscillator Block with:
  - Three External Clock modes up to 32 MHz

**TABLE 1: PIC16(L)F1764/5/8/9 FAMILY TYPES**

Device	Data Sheet Index	Program Memory Flash (Words/Kbytes)	High-Endurance Flash (B)	Data SRAM (Bytes)	I/O Pins <sup>(2)</sup>	16-Bit Timers	8-Bit Timers w/HLT	Comparator	10-Bit ADC (ch)	5/10-Bit DAC	CCP	10/16-Bit PWM	COG	Data Signal Modulator	CLC	Op Amp	Zero-Cross Detect	Programmable Ramp Gen	High-Current I/Os	Peripheral Pin Select	EUSART	I <sup>2</sup> C/SPI	Debug <sup>(1)</sup>
PIC16(L)F1764	(A)	4096/7	128	512	12	3	1/3	2	8	1/1	1	1/1	1	1	3	1	1	1	2	Y	1	1	I/H
PIC16(L)F1765	(A)	8192/14	128	1024	12	3	1/3	2	8	1/1	1	1/1	1	1	3	1	1	1	2	Y	1	1	I/H
PIC16(L)F1768	(A)	4096/7	128	512	18	3	1/3	4	12	2/2	2	2/2	2	2	3	2	1	2	2	Y	1	1	I/H
PIC16(L)F1769	(A)	8192/14	128	1024	18	3	1/3	4	12	2/2	2	2/2	2	2	3	2	1	2	2	Y	1	1	I/H

**Note 1:** Debugging Methods: (I) – Integrated on Chip; (H) – via ICD Header; E – Emulation Product.  
**Note 2:** One pin is input-only.

**Data Sheet Index:** (Unshaded devices are described in this document.)

A. DS-40001775 [PIC16\(L\)F1764/5/8/9 Data Sheet, 14/20-Pin 8-Bit Flash Microcontrollers.](#)

**Note:** For other small form factor package availability and marking information, please visit <http://www.microchip.com/packaging> or contact your local sales office.

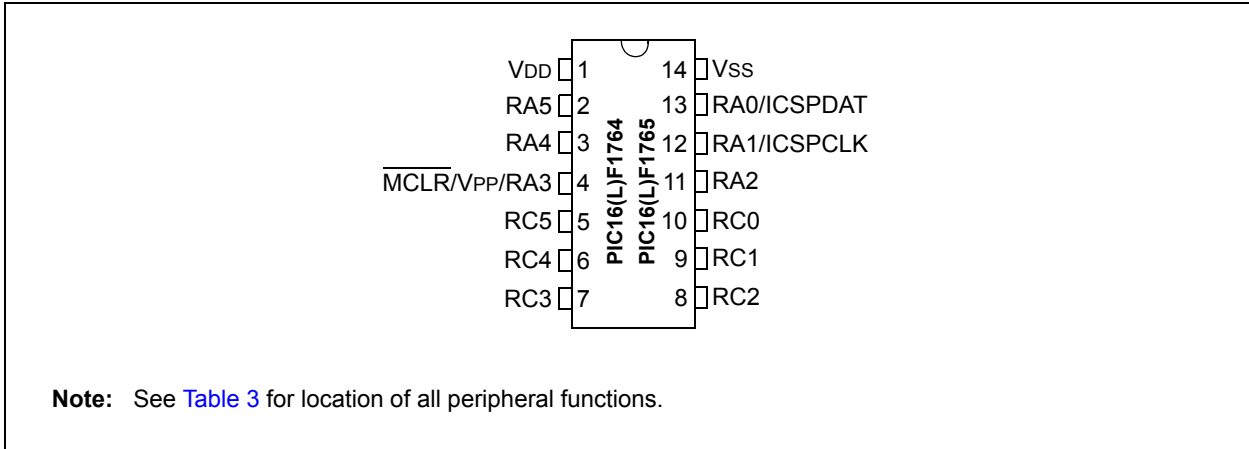
**TABLE 2: PACKAGES**

Packages	PDIP	SOIC	TSSOP	QFN	SSOP
PIC16(L)F1764	•	•	•	•	
PIC16(L)F1765	•	•	•	•	
PIC16(L)F1768	•	•		•	•
PIC16(L)F1769	•	•		•	•

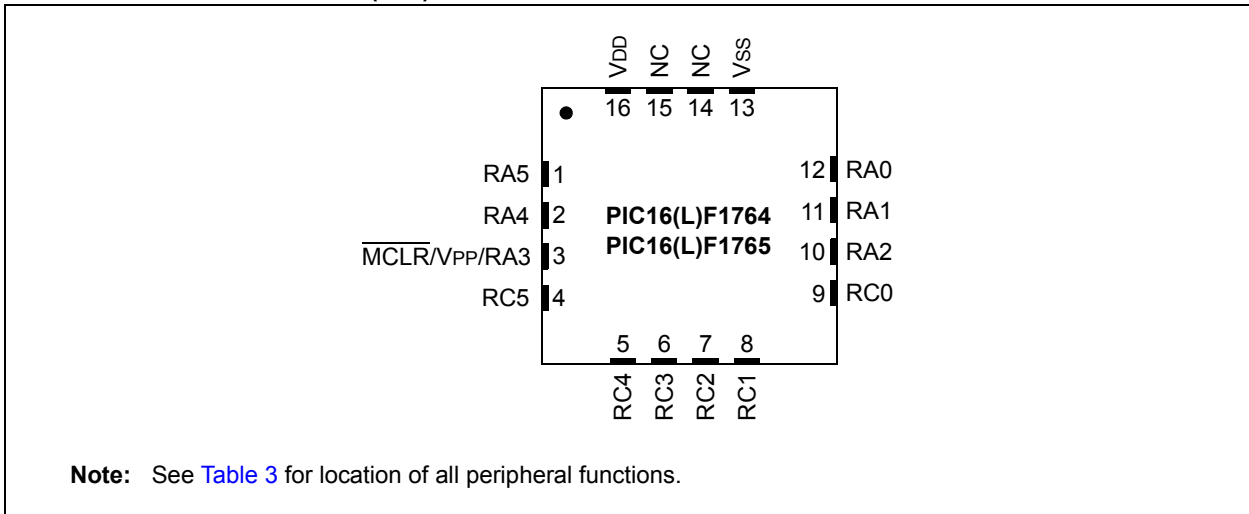
**Note:** Pin details are subject to change.

## PIN DIAGRAMS

**FIGURE 1: 14-PIN PDIP, SOIC, TSSOP**

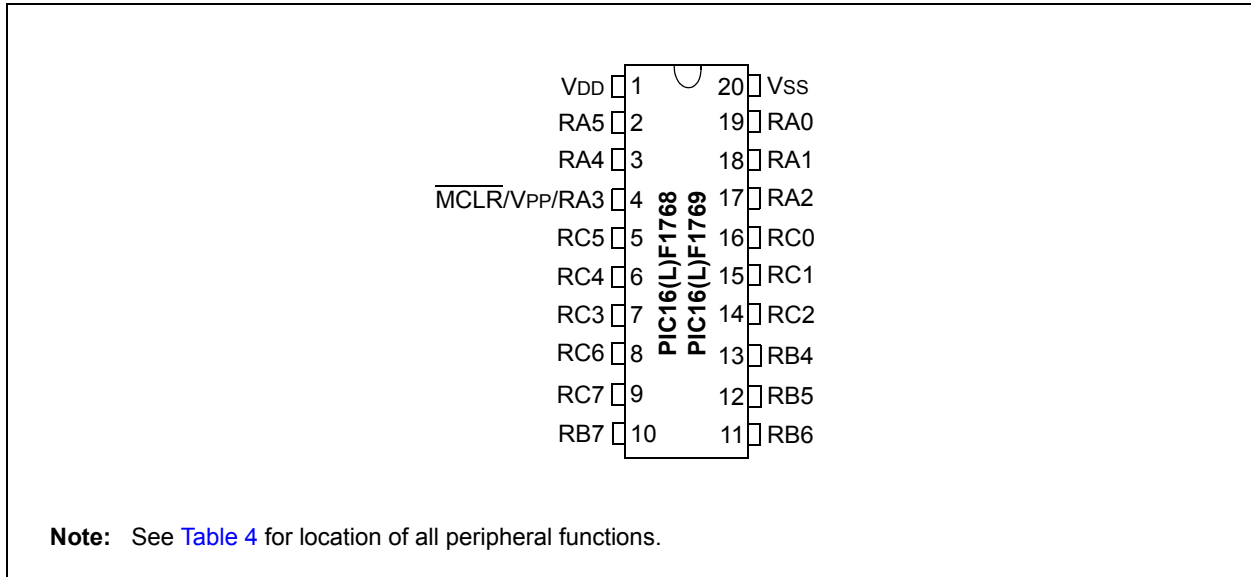


**FIGURE 2: 16-PIN QFN (4x4)**

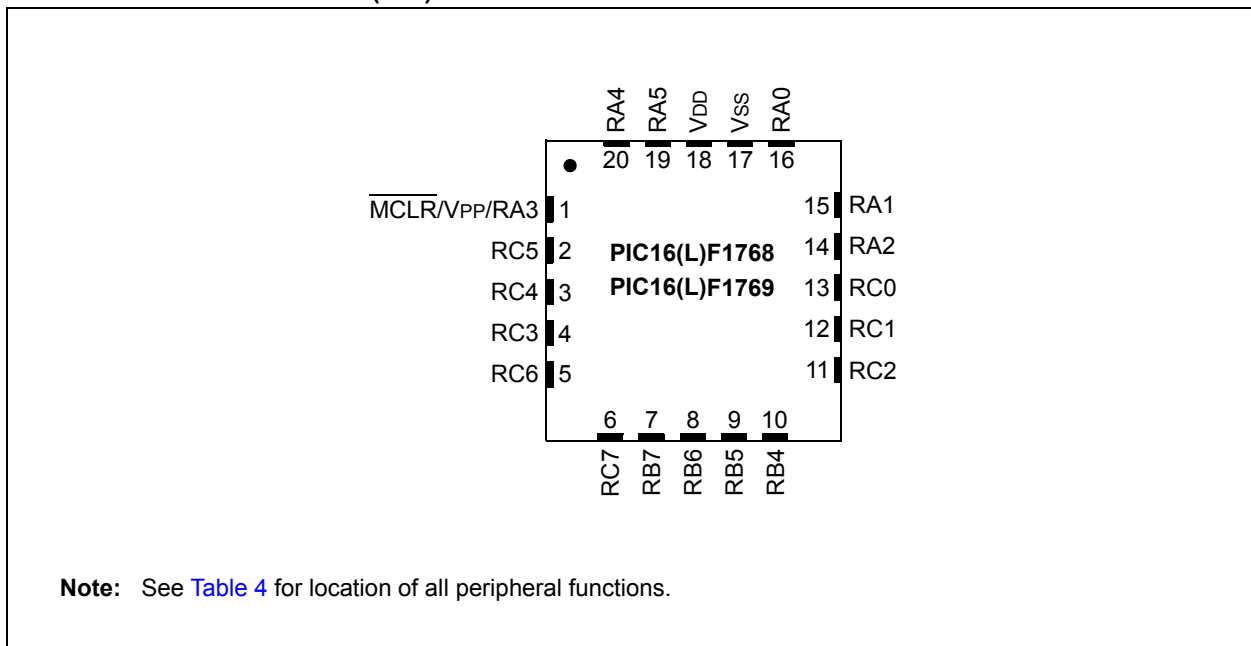


# PIC16(L)F1764/5/8/9

**FIGURE 3: 20-PIN PDIP, SOIC, SSOP**



**FIGURE 4: 20-PIN QFN (4x4)**



## PIN ALLOCATION TABLES

TABLE 3: 14-PIN AND 16-PIN ALLOCATION TABLE (PIC16(L)F1764/5)

I/O	14-Pin PDI/ISOIC/TSSOP	16-Pin QFN	ADC	Reference	DAC	Op Amp	Comparator	Zero Cross	Programmable Ramp Generator	Timers	PWM	CCP	COG	CLC	Modulator	EUSART	MSSP	Interrupts	Pull-ups	Hi Current	Basic
RA0	13	12	AN0	VREF- DAC1REF- DAC3REF-	DAC1OUT1 DAC3OUT1	—	C1IN0+	—	—	—	—	—	—	—	—	—	—	IOC	Y	—	ICSPDAT
RA1	12	11	AN1	VREF+ DAC1REF+ DAC3REF+	—	—	C1IN0- C2IN0-	—	—	—	—	—	—	—	—	—	—	IOC	Y	—	ICSPCLK
RA2	11	10	AN2	—	—	—	—	ZCD	—	T0CKI <sup>(1)</sup>	—	—	COG1IN <sup>(1)</sup>	—	—	—	—	INT <sup>(1)</sup> IOC	Y	—	—
RA3	4	3	—	—	—	—	—	—	—	T6IN <sup>(1)</sup>	—	—	—	—	MD1CH <sup>(1)</sup>	—	—	IOC	Y	—	VPP MCLR
RA4	3	2	AN3	—	—	—	—	—	—	T1G <sup>(1)</sup> SOSCO	—	—	—	—	MD1CL <sup>(1)</sup>	—	—	IOC	Y	—	OSC2 CLKOUT
RA5	2	1	—	—	—	—	—	—	—	T1CKI <sup>(1)</sup> T2IN <sup>(1)</sup> SOSCI	—	—	—	CLCIN3 <sup>(1)</sup>	MD1MOD <sup>(1)</sup>	—	—	IOC	Y	—	OSC1 CLKIN
RC0	10	9	AN4	—	—	OPA1IN+	C2IN0+	—	—	T5CKI <sup>(1)</sup>	—	—	—	—	—	—	SCL <sup>(1)</sup> SCK <sup>(1,3)</sup>	IOC	Y	—	—
RC1	9	8	AN5	—	—	OPA1IN-	C1IN1- C2IN1-	—	—	T4IN <sup>(1)</sup>	—	—	—	CLCIN2 <sup>(1)</sup>	—	—	SDI <sup>(1)</sup> SDA <sup>(1,3)</sup>	IOC	Y	—	—
RC2	8	7	AN6	—	—	OPA1OUT	C1IN2- C2IN2-	—	PRG1IN0	—	—	—	—	—	—	—	—	IOC	Y	—	—
RC3	7	6	AN7	—	—	—	C1IN3- C2IN3-	—	—	T5G <sup>(1)</sup>	—	—	—	CLCIN0 <sup>(1)</sup>	—	—	SS <sup>(1)</sup>	IOC	Y	—	—
RC4	6	5	—	—	—	—	—	—	PRG1R <sup>(1)</sup>	T3G <sup>(1)</sup>	—	—	—	CLCIN1 <sup>(1)</sup>	—	CK <sup>(1)</sup>	—	IOC	Y	Y	—
RC5	5	4	—	—	—	—	—	—	PRG1F <sup>(1)</sup>	T3CKI <sup>(1)</sup>	—	CCP1 <sup>(1)</sup>	—	—	—	RX <sup>(1,3)</sup>	—	IOC	Y	Y	—
VDD	1	16	—	—	—	—	—	—	—	—	—	—	—	—	—	—	—	—	—	—	VDD
VSS	14	13	—	—	—	—	—	—	—	—	—	—	—	—	—	—	—	—	—	—	VSS
OUT <sup>(2)</sup>	—	—	—	—	—	—	C1OUT	—	—	—	PWM3	CCP1	COG1A	CLC1OUT	MD1OUT	DT <sup>(3)</sup>	SDO	INT	—	—	—
	—	—	—	—	—	—	C2OUT	—	—	—	PWM5	—	COG1B	CLC2OUT	—	TX	SDA <sup>(3)</sup>	—	—	—	—
	—	—	—	—	—	—	—	—	—	—	—	—	COG1C	CLC3OUT	—	CK	SCK	—	—	—	—
	—	—	—	—	—	—	—	—	—	—	—	—	COG1D	—	—	—	SCL <sup>(3)</sup>	—	—	—	—

**Note 1:** Default peripheral input. Input can be moved to any other pin with the PPS Input Selection register. See [Table 12-1](#).

**Note 2:** All pin outputs default to PORT latch data. Any pin can be selected as a digital peripheral output with the PPS Output Selection registers. See [Table 12-2](#).

**Note 3:** These peripheral functions are bidirectional. The output pin selections must be the same as the input pin selections.

**TABLE 4: 20-PIN ALLOCATION TABLE (PIC16(L)F1768/9)**

I/O	20-Pin PDIP/SSOP	20-Pin QFN	ADC	Reference	DAC	Op Amp	Comparator	Zero Cross	Programmable Ramp Generator	Timers	PWM	CCP	COG	CLC	Modulator	EUSART	MSSP	Interrupts	Pull-ups	Hi Current	Basic	
RA0	19	16	AN0	VREF- DAC1REF- DAC2REF- DAC3REF- DAC4REF-	DAC1OUT1 DAC2OUT1 DAC3OUT1 DAC4OUT1	—	C1IN0+ C3IN0+	—	—	—	—	—	—	—	—	—	—	IO	Y	—	ICSPDAT	
RA1	18	15	AN1	VREF+ DAC1REF+ DAC2REF+ DAC3REF+ DAC4REF+	—	—	C1IN0- C2IN0- C3IN0- C4IN0-	—	—	—	—	—	—	—	—	—	—	—	IO	Y	—	ICSPCLK
RA2	17	14	AN2	—	—	—	—	ZCD	—	T0CKI <sup>(1)</sup>	—	—	COG1IN <sup>(1)</sup> COG2IN <sup>(1)</sup>	—	—	—	—	INT <sup>(1)</sup> IO	Y	—	—	
RA3 <sup>(4)</sup>	4	1	—	—	—	—	—	—	—	T6IN <sup>(1)</sup>	—	—	—	—	MD1CH <sup>(1)</sup> MD2CH <sup>(1)</sup>	—	—	IO	Y	—	VPP MCLR ICD	
RA4	3	20	AN3	—	—	—	—	—	—	T1G <sup>(1)</sup> SOSCO	—	—	—	—	MD1CL <sup>(1)</sup> MD2CL <sup>(1)</sup>	—	—	IO	Y	—	OSC2 CLKOUT	
RA5	2	19	—	—	—	—	—	—	—	T1CKI <sup>(1)</sup> T2IN <sup>(1)</sup> SOSCI	—	—	—	CLCIN3 <sup>(1)</sup>	MD1MOD <sup>(1)</sup> MD2MOD <sup>(1)</sup>	—	—	IO	Y	—	OSC1 CLKIN	
RB4	13	10	AN10	—	—	OPA1IN0-	—	—	—	—	—	—	—	—	—	—	SDI <sup>(1)</sup> SDA <sup>(1,3)</sup>	IO	Y	—	—	
RB5	12	9	AN11	—	—	OPA1IN0+	—	—	—	—	—	—	—	—	—	RX <sup>(1,3)</sup>	—	IO	Y	—	—	
RB6	11	8	—	—	—	—	C1IN1+ C3IN1+	—	—	—	—	—	—	—	—	—	SCL <sup>(1)</sup> SCK <sup>(1,3)</sup>	IO	Y	—	—	
RB7	10	7	—	—	—	—	C2IN1+ C4IN1+	—	—	—	—	—	—	—	—	CK <sup>(1)</sup>	—	IO	Y	—	—	
RC0	16	13	AN4	—	—	—	C2IN0+ C4IN0+	—	—	T5CKI <sup>(1)</sup>	—	—	—	—	—	—	—	IO	Y	—	—	
RC1	15	12	AN5	—	—	—	C1IN1- C2IN1- C3IN1- C4IN1-	—	—	T4IN <sup>(1)</sup>	—	—	—	CLCIN2 <sup>(1)</sup>	—	—	—	IO	Y	—	—	
RC2	14	11	AN6	—	—	OPA1OUT OPA2IN1- OPA2IN1+	C1IN2- C2IN2-	—	PRG1IN0 PRG2IN1	—	—	—	—	—	—	—	—	IO	Y	—	—	

- Note**
- 1: Default peripheral input. Input can be moved to any other pin with the PPS Input Selection register. See [Table 12-1](#).
  - 2: All pin outputs default to PORT latch data. Any input capable pin can be selected as a digital peripheral output with the PPS Output Selection registers. See [Table 12-2](#).
  - 3: These peripheral functions are bidirectional. The output pin selections must be the same as the input pin selections.
  - 4: Input only.

**TABLE 4: 20-PIN ALLOCATION TABLE (PIC16(L)F1768/9) (CONTINUED)**

I/O	20-Pin PDIP/SOIC/SSOP	20-Pin QFN	ADC	Reference	DAC	Op Amp	Comparator	Zero Cross	Programmable Ramp Generator	Timers	PWM	CCP	COG	CLC	Modulator	EUSART	MSSP	Interrupts	Pull-ups	Hi Current	Basic		
RC3	7	4	AN7	—	—	OPA2OUT OPA1IN1- OPA1IN1+	C1IN3- C2IN3- C3IN3- C4IN3-	—	PRG2IN0 PRG1IN1	T5G <sup>(1)</sup>	—	CCP2 <sup>(1)</sup>	—	CLCIN0 <sup>(1)</sup>	—	—	—	—	IOC	Y	—	—	
RC4	6	3	—	—	—	—	—	—	PRG1R <sup>(1)</sup> PRG2R <sup>(1)</sup>	T3G <sup>(1)</sup>	—	—	—	CLCIN1 <sup>(1)</sup>	—	—	—	—	IOC	Y	Y	—	
RC5	5	2	—	—	—	—	—	—	PRG1F <sup>(1)</sup> PRG2F <sup>(1)</sup>	T3CKI <sup>(1)</sup>	—	CCP1 <sup>(1)</sup>	—	—	—	—	—	—	IOC	Y	Y	—	
RC6	8	5	AN8	—	—	OPA2IN0-	—	—	—	—	—	—	—	—	—	—	SS <sup>(1)</sup>	—	IOC	Y	—	—	
RC7	9	6	AN9	—	—	OPA2IN0+	—	—	—	—	—	—	—	—	—	—	—	—	IOC	Y	—	—	
VDD	1	18	—	—	—	—	—	—	—	—	—	—	—	—	—	—	—	—	—	—	—	—	
VSS	20	17	—	—	—	—	—	—	—	—	—	—	—	—	—	—	—	—	—	—	—	—	
OUT <sup>(2)</sup>	—	—	—	—	—	—	C1OUT	—	—	—	PWM3	CCP1	COG1A	CLC1OUT	MD1OUT	DT <sup>(3)</sup>	SDO	—	—	—	—	—	
	—	—	—	—	—	—	C2OUT	—	—	—	PWM4	CCP2	COG1B	CLC2OUT	MD2OUT	TX	SDA <sup>(3)</sup>	—	—	—	—	—	
	—	—	—	—	—	—	C3OUT	—	—	—	PWM5	—	COG1C	CLC3OUT	—	CK	SCK	—	—	—	—	—	
	—	—	—	—	—	—	C4OUT	—	—	—	PWM6	—	COG1D	—	—	—	SCL <sup>(3)</sup>	—	—	—	—	—	
	—	—	—	—	—	—	—	—	—	—	—	—	COG2A	—	—	—	—	—	—	—	—	—	
	—	—	—	—	—	—	—	—	—	—	—	—	COG2B	—	—	—	—	—	—	—	—	—	—
	—	—	—	—	—	—	—	—	—	—	—	—	COG2C	—	—	—	—	—	—	—	—	—	—
—	—	—	—	—	—	—	—	—	—	—	—	COG2D	—	—	—	—	—	—	—	—	—	—	

- Note**
- 1: Default peripheral input. Input can be moved to any other pin with the PPS Input Selection register. See [Table 12-1](#).
  - 2: All pin outputs default to PORT latch data. Any input capable pin can be selected as a digital peripheral output with the PPS Output Selection registers. See [Table 12-2](#).
  - 3: These peripheral functions are bidirectional. The output pin selections must be the same as the input pin selections.
  - 4: Input only.

## Table of Contents

1.0	Device Overview .....	10
2.0	Enhanced Mid-Range CPU .....	22
3.0	Memory Organization .....	24
4.0	Device Configuration .....	62
5.0	Oscillator Module (with Fail-Safe Clock Monitor) .....	70
6.0	Resets .....	87
7.0	Interrupts .....	96
8.0	Power-Down Mode (Sleep) .....	111
9.0	Watchdog Timer (WDT) .....	115
10.0	Flash Program Memory Control .....	119
11.0	I/O Ports .....	136
12.0	Peripheral Pin Select (PPS) Module .....	154
13.0	Interrupt-On-Change .....	162
14.0	Fixed Voltage Reference (FVR) .....	169
15.0	Temperature Indicator Module .....	172
16.0	Analog-to-Digital Converter (ADC) Module .....	174
17.0	5-Bit Digital-to-Analog Converter (DAC) Module .....	188
18.0	10-Bit Digital-to-Analog Converter (DAC) Module .....	192
19.0	Comparator Module .....	198
20.0	Zero-Cross Detection (ZCD) Module .....	208
21.0	Timer0 Module .....	214
22.0	Timer1/3/5 Module with Gate Control .....	217
23.0	Timer2/4/6 Module .....	228
24.0	Capture/Compare/PWM Modules .....	250
25.0	10-Bit Pulse-Width Modulation (PWM) Module .....	263
26.0	16-Bit Pulse-Width Modulation (PWM) Module .....	269
27.0	Complementary Output Generator (COG) Module .....	295
28.0	Configurable Logic Cell (CLC) .....	334
29.0	Operational Amplifier (OPA) Modules .....	348
30.0	Programmable Ramp Generator (PRG) Module .....	354
31.0	Data Signal Modulator (DSM) .....	370
32.0	Master Synchronous Serial Port (MSSP) Module .....	380
33.0	Enhanced Universal Synchronous Asynchronous Receiver Transmitter (EUSART) .....	435
34.0	In-Circuit Serial Programming™ (ICSP™) .....	465
35.0	Instruction Set Summary .....	467
36.0	Electrical Specifications .....	481
37.0	DC and AC Characteristics Graphs and Charts .....	515
38.0	Development Support .....	537
39.0	Packaging Information .....	541
Appendix A: Data Sheet Revision History .....		563
The Microchip WebSite .....		564
Customer Change Notification Service .....		564
Customer Support .....		564
Product Identification System .....		566
Worldwide Sales and Service .....		568



## TO OUR VALUED CUSTOMERS

It is our intention to provide our valued customers with the best documentation possible to ensure successful use of your Microchip products. To this end, we will continue to improve our publications to better suit your needs. Our publications will be refined and enhanced as new volumes and updates are introduced.

If you have any questions or comments regarding this publication, please contact the Marketing Communications Department via E-mail at [docerrors@microchip.com](mailto:docerrors@microchip.com). We welcome your feedback.

### Most Current Data Sheet

To obtain the most up-to-date version of this data sheet, please register at our Worldwide Website at:

<http://www.microchip.com>

You can determine the version of a data sheet by examining its literature number found on the bottom outside corner of any page. The last character of the literature number is the version number, (e.g., DS30000000A is version A of document DS30000000).

### Errata

An errata sheet, describing minor operational differences from the data sheet and recommended workarounds, may exist for current devices. As device/documentation issues become known to us, we will publish an errata sheet. The errata will specify the revision of silicon and revision of document to which it applies.

To determine if an errata sheet exists for a particular device, please check with one of the following:

- Microchip's Worldwide Website; <http://www.microchip.com>
- Your local Microchip sales office (see last page)

When contacting a sales office, please specify which device, revision of silicon and data sheet (include literature number) you are using.

### Customer Notification System

Register on our website at [www.microchip.com](http://www.microchip.com) to receive the most current information on all of our products.

# PIC16(L)F1764/5/8/9

## 1.0 DEVICE OVERVIEW

The PIC16(L)F1764/5/8/9 are described within this data sheet. See [Table 2](#) for available package configurations.

[Figure 1-1](#) shows a block diagram of the PIC16(L)F1764/5 devices. [Figure 1-2](#) shows a block diagram of the PIC16(L)F1768/9 devices. [Table 1-2](#) and [Table 1-3](#) show the pinout descriptions.

Refer to [Table 1-1](#) for peripherals available per device.

**TABLE 1-1: DEVICE PERIPHERAL SUMMARY**

Peripheral	PIC16(L)F1764	PIC16(L)F1765	PIC16(L)F1768	PIC16(L)F1769
Analog-to-Digital Converter (ADC)	•	•	•	•
Fixed Voltage Reference (FVR)	•	•	•	•
Zero-Cross Detection (ZCD)	•	•	•	•
Temperature Indicator	•	•	•	•
Complementary Output Generator (COG)				
	COG1	•	•	•
	COG2		•	•
Programmable Ramp Generator (PRG)				
	PRG1	•	•	•
	PRG2		•	•
10-Bit Digital-to-Analog Converter (DAC)				
	DAC1	•	•	•
	DAC2		•	•
5-Bit Digital-to-Analog Converter (DAC)				
	DAC3	•	•	•
	DAC4		•	•
Capture/Compare/PWM (CCP/ECCP) Modules				
	CCP1	•	•	•
	CCP2		•	•
Comparators				
	C1	•	•	•
	C2	•	•	•
	C3		•	•
	C4		•	•
Configurable Logic Cell (CLC)				
	CLC1	•	•	•
	CLC2	•	•	•
	CLC3	•	•	•
Data Signal Modulator (DSM)				
	DSM1	•	•	•
	DSM2		•	•

**TABLE 1-1: DEVICE PERIPHERAL SUMMARY (CONTINUED)**

Peripheral	PIC16(L)F1764	PIC16(L)F1765	PIC16(L)F1768	PIC16(L)F1769
Enhanced Universal Synchronous/Asynchronous Receiver/Transmitter (EUSART)				
	EUSART	•	•	•
Master Synchronous Serial Ports				
	MSSP	•	•	•
Op Amp				
	Op Amp 1	•	•	•
	Op Amp 2		•	•
10-Bit Pulse-Width Modulator (PWM)				
	PWM3	•	•	•
	PWM4		•	•
16-Bit Pulse-Width Modulator (PWM)				
	PWM5	•	•	•
	PWM6		•	•
8-Bit Timers				
	Timer0	•	•	•
	Timer2	•	•	•
	Timer4	•	•	•
	Timer6	•	•	•
16-Bit Timers				
	Timer1	•	•	•
	Timer3	•	•	•
	Timer5	•	•	•

## 1.1 Register and Bit Naming Conventions

### 1.1.1 REGISTER NAMES

When there are multiple instances of the same peripheral in a device, the peripheral control registers will be depicted as the concatenation of a peripheral identifier, peripheral instance and control identifier. The control registers section will show just one instance of all the register names with an 'x' in the place of the peripheral instance number. This naming convention may also be applied to peripherals when there is only one instance of that peripheral in the device to maintain compatibility with other devices in the family that contain more than one.

### 1.1.2 BIT NAMES

There are two variants for bit names:

- Short name: Bit function abbreviation
- Long name: Peripheral abbreviation + short name

#### 1.1.2.1 Short Bit Names

Short bit names are an abbreviation for the bit function. For example, some peripherals are enabled with the EN bit. The bit names shown in the registers are the short name variant.

Short bit names are useful when accessing bits in C programs. The general format for accessing bits by the short name is *RegisterNamebits.ShortName*. For example, the enable bit, EN, in the COG1CON0 register can be set in C programs with the instruction `COG1CON0bits.EN = 1`.

Short names are generally not useful in assembly programs because the same name may be used by different peripherals in different bit positions. When this occurs, during the include file generation, all instances of that short bit name are appended with an underscore plus the name of the register in which the bit resides to avoid naming contentions.

#### 1.1.2.2 Long Bit Names

Long bit names are constructed by adding a peripheral abbreviation prefix to the short name. The prefix is unique to the peripheral thereby making every long bit name unique. The long bit name for the COG1 enable bit is the COG1 prefix, G1, appended with the enable bit short name, EN, resulting in the unique bit name G1EN.

Long bit names are useful in both C and assembly programs. For example, in C the COG1CON0 enable bit can be set with the `G1EN = 1` instruction. In assembly, this bit can be set with the `BSF COG1CON0,G1EN` instruction.

### 1.1.2.3 Bit Fields

Bit fields are two or more adjacent bits in the same register. Bit fields adhere only to the short bit naming convention. For example, the three Least Significant bits of the COG1CON0 register contain the mode control bits. The short name for this field is MD. There is no long bit name variant. Bit field access is only possible in C programs. The following example demonstrates a C program instruction for setting the COG1 to the Push-Pull mode:

```
COG1CON0bits.MD = 0x5;
```

Individual bits in a bit field can also be accessed with long and short bit names. Each bit is the field name appended with the number of the bit position within the field. For example, the Most Significant mode bit has the short bit name MD2, and the long bit name is G1MD2. The following two examples demonstrate assembly program sequences for setting the COG1 to Push-Pull mode:

Example 1:

```
MOVLW  ~(1<<G1MD1)
ANDWF  COG1CON0,F
MOVLW  1<<G1MD2 | 1<<G1MD0
IORWF  COG1CON0,F
```

Example 2:

```
BSF    COG1CON0,G1MD2
BCF    COG1CON0,G1MD1
BSF    COG1CON0,G1MD0
```

## 1.1.3 REGISTER AND BIT NAMING EXCEPTIONS

### 1.1.3.1 Status, Interrupt and Mirror Bits

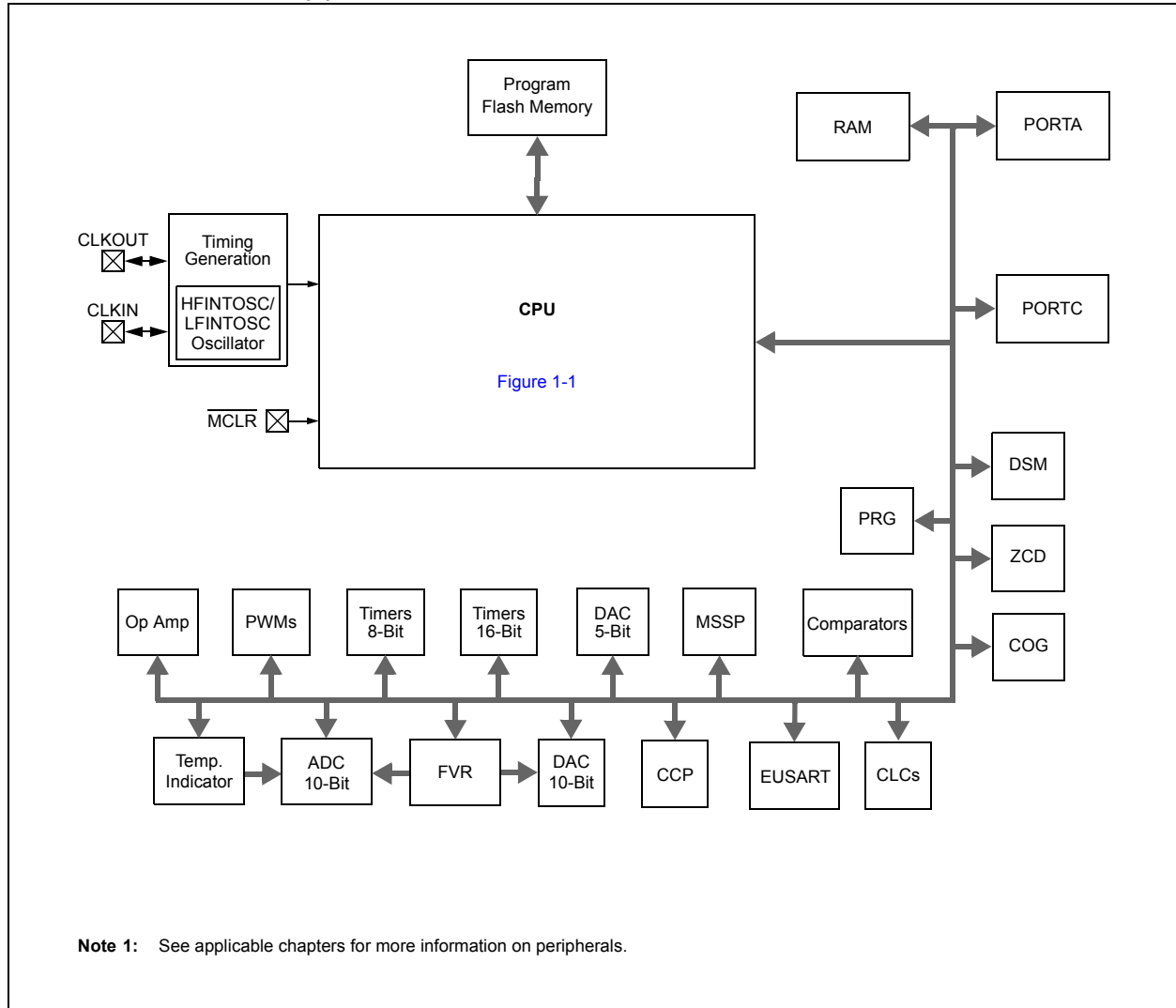
Status, interrupt enables, interrupt flags and mirror bits are contained in registers that span more than one peripheral. In these cases, the bit name shown is unique, so there is no prefix or short name variant.

### 1.1.3.2 Legacy Peripherals

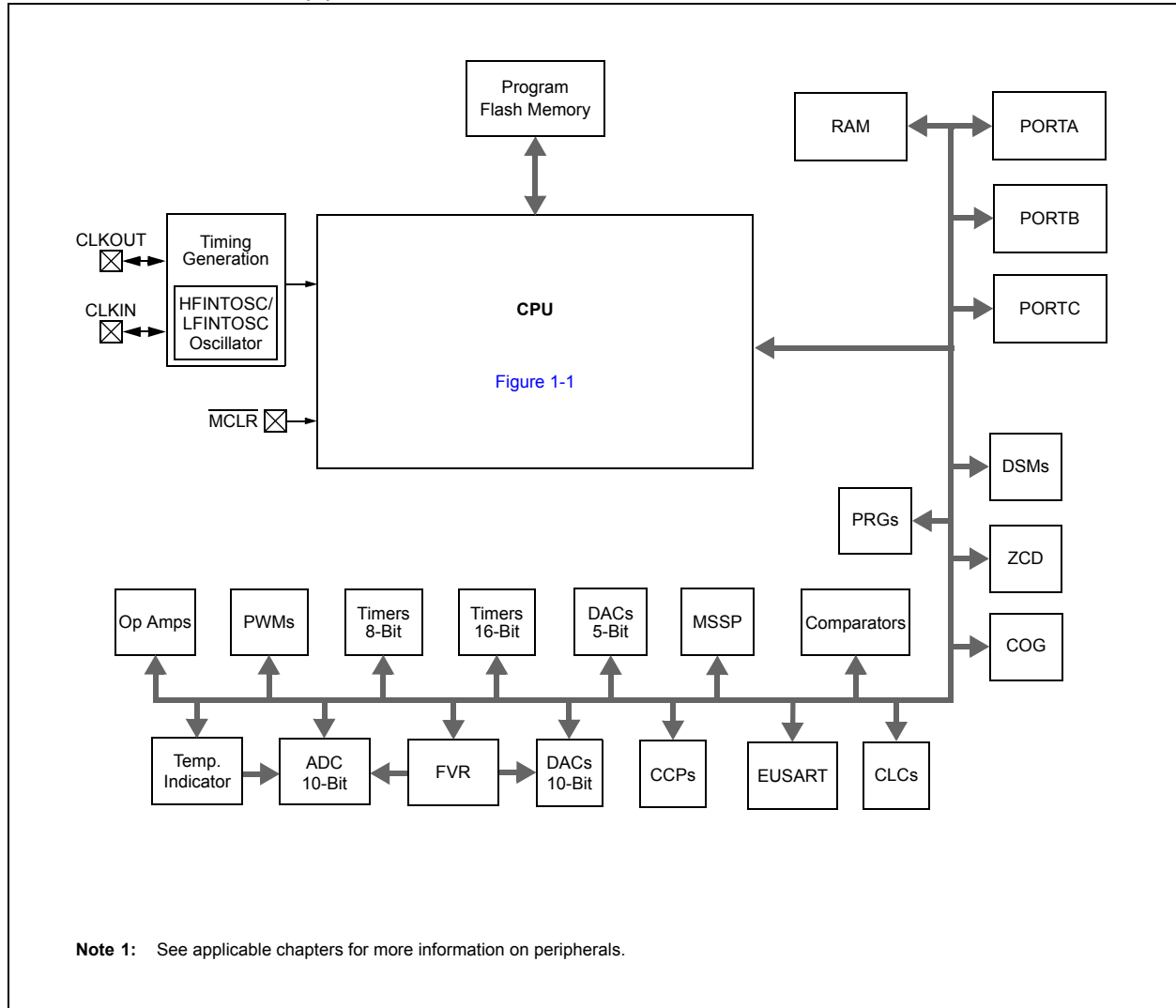
There are some peripherals that do not strictly adhere to these naming conventions. Peripherals that have existed for many years and are present in almost every device are the exceptions. These exceptions were necessary to limit the adverse impact of the new conventions on legacy code. Peripherals that do adhere to the new convention will include a table in the registers section indicating the long name prefix for each peripheral instance. Peripherals that fall into the exception category will not have this table. These peripherals include, but are not limited to, the following:

- EUSART
- MSSP

**FIGURE 1-1: PIC16(L)F1764/5 BLOCK DIAGRAM**



**FIGURE 1-2: PIC16(L)F1768/9 BLOCK DIAGRAM**



**Note 1:** See applicable chapters for more information on peripherals.

# PIC16(L)F1764/5/8/9

**TABLE 1-2: PIC16(L)F1764/5 PINOUT DESCRIPTION**

Name	Function	Input Type	Output Type	Description
RA0/AN0/C1IN0+/VREF-/ DAC1REF-/DAC3REF-/ DAC1OUT1/DAC3OUT1/ ICSPDAT	RA0	TTL/ST	CMOS	General purpose I/O.
	AN0	AN	—	ADC Channel 0 input.
	C1IN0+	AN	—	Comparator C1 positive input.
	VREF-	AN	—	ADC negative reference.
	DAC1REF-	AN	—	DAC1 negative reference.
	DAC3REF-	AN	—	DAC3 negative reference.
	DAC1OUT1	—	AN	DAC1 voltage output.
	DAC3OUT1	—	AN	DAC3 voltage output.
ICSPDAT	ST	CMOS	ICSP™ data I/O.	
RA1/AN1/C1IN0-/C2IN0-/VREF+/ DAC1REF+/DAC3REF+/ ICSPCLK	RA1	TTL/ST	CMOS	General purpose I/O.
	AN1	AN	—	ADC Channel 1 input.
	C1IN0-	AN	—	Comparator C1 negative input.
	C2IN0-	AN	—	Comparator C2 negative input.
	VREF+	AN	—	ADC positive reference.
	DAC1REF+	AN	—	DAC1 positive reference.
	DAC3REF+	AN	—	DAC3 positive reference.
	ICSPCLK	ST	—	Serial programming clock.
RA2/AN2/ZCD/T0CKI/COG1IN/ INT	RA2	TTL/ST	CMOS	General purpose I/O.
	AN2	AN	—	ADC Channel 2 input.
	ZCD	AN	—	Zero-Cross Detection input.
	T0CKI	TTL/ST	—	Timer0 clock input.
	COG1IN <sup>(1)</sup>	TTL/ST	—	Complementary Output Generator 1 input.
INT <sup>(1)</sup>	TTL/ST	—	Interrupt input.	
RA3/T6IN/MD1CH/MCLR/VPP	RA3	TTL/ST	—	General purpose input.
	T6IN <sup>(1)</sup>	TTL/ST	—	Timer6 clock input.
	MD1CH <sup>(1)</sup>	TTL/ST	—	Data Signal Modulator 1 high carrier input.
	MCLR	ST	—	Master Clear input.
	VPP	HV	—	Programming enable.
RA4/AN3/SOSCO/T1G/ MD1CL/OSC2/CLKOUT	RA4	TTL/ST	CMOS	General purpose I/O.
	AN3	AN	—	ADC Channel 3 input.
	SOSCO	—	XTAL	Secondary Oscillator connection.
	T1G <sup>(1)</sup>	TTL/ST	—	Timer1 gate input.
	MD1CL <sup>(1)</sup>	TTL/ST	—	Data Signal Modulator 1 low carrier input.
	OSC2	—	XTAL	Crystal/Resonator (LP, XT, HS modes).
CLKOUT	—	CMOS	Fosc/4 output.	

**Legend:** AN = Analog input or output    CMOS = CMOS compatible input or output    OD = Open-Drain  
TTL = TTL compatible input    ST = Schmitt Trigger input with CMOS levels    I<sup>2</sup>C = Schmitt Trigger input with I<sup>2</sup>C  
HV = High Voltage    XTAL = Crystal levels

- Note 1:** Default peripheral input. Alternate pins can be selected as the peripheral input with the PPS Input Selection registers.  
**Note 2:** All pin digital outputs default to PORT latch data. Alternate outputs can be selected as peripheral digital outputs with the PPS Output Selection registers.  
**Note 3:** These peripheral functions are bidirectional. The output pin selections must be the same as the input pin selections.

# PIC16(L)F1764/5/8/9

**TABLE 1-2: PIC16(L)F1764/5 PINOUT DESCRIPTION (CONTINUED)**

Name	Function	Input Type	Output Type	Description
RA5/T1CKI/T2IN/CLCIN3/ MD1MOD/SOSCI/OSC1/CLKIN	RA5	TTL/ST	CMOS	General purpose I/O.
	T1CKI <sup>(1)</sup>	TTL/ST	—	Timer1 clock input.
	T2IN <sup>(1)</sup>	TTL/ST	—	Timer2 clock input.
	CLCIN3 <sup>(1)</sup>	TTL/ST	—	CLC Input 3.
	MD1MOD <sup>(1)</sup>	TTL/ST	—	Data Signal Modulator modulation input.
	SOSCI	—	XTAL	Secondary Oscillator connection.
	OSC1	XTAL	—	Crystal/Resonator (LP, XT, HS modes).
RC0/AN4/OPA1IN+/C2IN0+/ T5CKI/SCL/SCK	RC0	TTL/ST	CMOS	General purpose I/O.
	AN4	AN	—	ADC Channel 4 input.
	OPA1IN+	AN	—	Operational Amplifier 1 noninverting input.
	C2IN0+	AN	—	Comparator 2 positive input.
	T5CKI <sup>(1)</sup>	TTL/ST	—	Timer5 clock input.
	SCL <sup>(1,3)</sup>	I <sup>2</sup> C	—	I <sup>2</sup> C clock output.
	SCK <sup>(1)</sup>	TTL/ST	—	SPI clock input.
RC1/AN5/OPA1IN-/C1IN1-/ C2IN1-/T4IN/CLCIN2/SDI/SDA	RC1	TTL/ST	CMOS	General purpose I/O.
	AN5	AN	XTAL	ADC Channel 5 input.
	OPA1IN-	AN	—	Operational Amplifier 1 inverting input.
	C1IN1-	AN	—	Comparator 1 negative input.
	C2IN1-	AN	—	Comparator 2 negative input.
	T4IN <sup>(1)</sup>	TTL/ST	—	Timer4 clock input.
	CLCIN2 <sup>(1)</sup>	TTL/ST	—	CLC Input 2.
RC2/AN6/OPA1OUT/C1IN2-/ C2IN2-/PRG1IN0	RC2	TTL/ST	CMOS	General purpose I/O.
	AN6	AN	—	ADC Channel 6 input.
	OPA1OUT	—	AN	Operational Amplifier 1 output.
	C1IN2-	AN	—	Comparator 1 negative input.
	C2IN2-	AN	—	Comparator 2 negative input.
	PRG1IN0	AN	—	Ramp Generator 1 reference voltage input.
RC3/AN7/C1IN3-/C2IN3-/T5G/ CLCIN0/SS	RC3	TTL/ST	CMOS	General purpose I/O.
	AN7	AN	—	ADC Channel 7 input.
	C1IN3-	AN	—	Comparator 1 negative input.
	C2IN3-	AN	—	Comparator 2 negative input.
	T5G <sup>(1)</sup>	TTL/ST	—	Timer5 gate input.
	CLCIN0 <sup>(1)</sup>	TTL/ST	—	CLC Input 0.
SS <sup>(1)</sup>	TTL/ST	—	SPI Slave Select input.	

**Legend:** AN = Analog input or output    CMOS = CMOS compatible input or output    OD = Open-Drain  
TTL = TTL compatible input    ST = Schmitt Trigger input with CMOS levels    I<sup>2</sup>C = Schmitt Trigger input with I<sup>2</sup>C  
HV = High Voltage    XTAL = Crystal levels

- Note 1:** Default peripheral input. Alternate pins can be selected as the peripheral input with the PPS Input Selection registers.  
**Note 2:** All pin digital outputs default to PORT latch data. Alternate outputs can be selected as peripheral digital outputs with the PPS Output Selection registers.  
**Note 3:** These peripheral functions are bidirectional. The output pin selections must be the same as the input pin selections.

# PIC16(L)F1764/5/8/9

**TABLE 1-2: PIC16(L)F1764/5 PINOUT DESCRIPTION (CONTINUED)**

Name	Function	Input Type	Output Type	Description
RC4/T3G/PRG1R/CLCIN1/CK	RC4	TTL/ST	CMOS	General purpose I/O.
	T3G <sup>(1)</sup>	TTL/ST	—	Timer3 gate input.
	PRG1R <sup>(1)</sup>	TTL/ST	—	Ramp generator set_rising input.
	CLCIN1 <sup>(1)</sup>	TTL/ST	—	CLC Input 1.
	CK <sup>(1)</sup>	TTL/ST	—	EUSART clock input.
RC5/T3CKI/PRG1F/CCP1/RX	RC5	TTL/ST	CMOS	General purpose I/O.
	T3CKI <sup>(1)</sup>	TTL/ST	—	Timer3 clock input.
	PRG1F <sup>(1)</sup>	TTL/ST	—	Ramp generator set_falling input.
	CCP1 <sup>(1)</sup>	TTL/ST	—	CCP1 capture input.
	RX <sup>(1,3)</sup>	TTL/ST	—	EUSART receive input.
VDD	VDD	Power	—	Positive supply.
VSS	VSS	Power	—	Ground reference.
OUT <sup>(2)</sup>	C1OUT		CMOS	Comparator 1 output.
	C2OUT		CMOS	Comparator 2 output.
	CCP1		CMOS	Compare/PWM1 output.
	MD1OUT		CMOS	Data Signal Modulator 1 output.
	PWM3		CMOS	PWM3 output.
	PWM5		CMOS	PWM5 output.
	COG1A		CMOS	Complementary Output Generator Output A.
	COG1B		CMOS	Complementary Output Generator Output B.
	COG1C		CMOS	Complementary Output Generator Output C.
	COG1D		CMOS	Complementary Output Generator Output D.
	SDA <sup>(3)</sup>		OD	I <sup>2</sup> C data output.
	SCK		CMOS	SPI clock output.
	SCL <sup>(3)</sup>		OD	I <sup>2</sup> C clock output.
	SDO		CMOS	SPI data output.
	TX		CMOS	EUSART asynchronous TX data out.
	CK		CMOS	EUSART synchronous clock out.
	DT <sup>(3)</sup>		CMOS	EUSART synchronous data output.
	CLC1OUT		CMOS	Configurable Logic Cell 1 output.
	CLC2OUT		CMOS	Configurable Logic Cell 2 output.
	CLC3OUT		CMOS	Configurable Logic Cell 3 output.

**Legend:** AN = Analog input or output    CMOS = CMOS compatible input or output    OD = Open-Drain  
TTL = TTL compatible input    ST = Schmitt Trigger input with CMOS levels    I<sup>2</sup>C = Schmitt Trigger input with I<sup>2</sup>C  
HV = High Voltage    XTAL = Crystal levels

- Note 1:** Default peripheral input. Alternate pins can be selected as the peripheral input with the PPS Input Selection registers.  
**Note 2:** All pin digital outputs default to PORT latch data. Alternate outputs can be selected as peripheral digital outputs with the PPS Output Selection registers.  
**Note 3:** These peripheral functions are bidirectional. The output pin selections must be the same as the input pin selections.



**TABLE 1-3: PIC16(L)F1768/9 PINOUT DESCRIPTION**

Name	Function	Input Type	Output Type	Description
RA0/AN0/C1IN0+/C3IN0+/VREF-/ DAC1REF-/DAC2REF-/ DAC3REF-/DAC4REF-/ DAC1OUT1/DAC2OUT1./ DAC3OUT1/DAC4OUT1/ ICSPDAT	RA0	TTL/ST	CMOS	General purpose I/O.
	AN0	AN	—	ADC Channel 0 input.
	C1IN0+	AN	—	Comparator C1 positive input.
	C3IN0+	AN	—	Comparator C3 positive input.
	DAC1REF-	AN	—	DAC1 negative reference.
	DAC2REF-	AN	—	DAC2 negative reference.
	DAC3REF-	AN	—	DAC3 negative reference.
	DAC4REF-	AN	—	DAC4 negative reference.
	DAC1OUT1	—	AN	DAC1 voltage output.
	DAC2OUT1	—	AN	DAC2 voltage output.
	DAC3OUT1	—	AN	DAC3 voltage output.
	DAC4OUT1	—	AN	DAC4 voltage output.
	VREF-	AN	—	ADC negative reference.
ICSPDAT	ST	CMOS	ICSP™ data I/O.	
RA1/AN1/C1IN0-/C2IN0-/ C3IN0-/C4IN0-/VREF+/ DAC1REF+/DAC2REF+/ DAC3REF+/DAC4REF+/ ICSPCLK	RA1	TTL/ST	CMOS	General purpose I/O.
	AN1	AN	—	ADC Channel 1 input.
	C1IN0-	AN	—	Comparator C1 negative input.
	C2IN0-	AN	—	Comparator C2 negative input.
	C3IN0-	AN	—	Comparator C3 negative input.
	C4IN0-	AN	—	Comparator C4 negative input.
	DAC1REF+	AN	—	DAC1 positive reference.
	DAC2REF+	AN	—	DAC2 positive reference.
	DAC3REF+	AN	—	DAC3 positive reference.
	DAC4REF+	AN	—	DAC4 positive reference.
	VREF+	AN	—	ADC positive reference.
ICSPCLK	ST	—	Serial programming clock.	
RA2/AN2/ZCD/T0CKI/COG1IN/ COG2IN/INT	RA2	TTL/ST	CMOS	General purpose I/O.
	AN2	AN	—	ADC Channel 2 input.
	ZCD	AN	—	Zero-Cross Detection input.
	T0CKI <sup>(1)</sup>	TTL/ST	—	Timer0 clock input.
	COG1IN <sup>(1)</sup>	TTL/ST	—	Complementary Output Generator 1 input.
	COG2IN <sup>(1)</sup>	TTL/ST	—	Complementary Output Generator 2 input.
	INT <sup>(1)</sup>	TTL/ST	—	Interrupt input.
RA3/T6IN/MD1CH/MD2CH/ MCLR/VPP	RA3	TTL/ST	—	General purpose input.
	T6IN <sup>(1)</sup>	TTL/ST	—	Timer6 clock input.
	MD1CH <sup>(1)</sup>	TTL/ST	—	Data Signal Modulator 1 high carrier input.
	MD2CH <sup>(1)</sup>	TTL/ST	—	Data Signal Modulator 2 high carrier input.
	MCLR	ST	—	Master Clear input.
	VPP	HV	—	Programming enable.

**Legend:** AN = Analog input or output    CMOS = CMOS compatible input or output    OD = Open-Drain  
TTL = TTL compatible input    ST = Schmitt Trigger input with CMOS levels    I<sup>2</sup>C = Schmitt Trigger input with I<sup>2</sup>C  
HV = High Voltage    XTAL = Crystal levels

- Note 1:** Default peripheral input. Alternate pins can be selected as the peripheral input with the PPS Input Selection registers.  
**2:** All pin digital outputs default to PORT latch data. Alternate outputs can be selected as peripheral digital outputs with the PPS Output Selection registers.  
**3:** These peripheral functions are bidirectional. The output pin selections must be the same as the input pin selections.

# PIC16(L)F1764/5/8/9

**TABLE 1-3: PIC16(L)F1768/9 PINOUT DESCRIPTION (CONTINUED)**

Name	Function	Input Type	Output Type	Description
RA4/AN3/SOSCO/T1G/ DSM1CL/DSM2CL/OSC2/ CLKOUT	RA4	TTL/ST	CMOS	General purpose I/O.
	AN3	AN	—	ADC Channel 3 input.
	SOSCO	—	XTAL	Secondary Oscillator connection.
	T1G <sup>(1)</sup>	TTL/ST	—	Timer1 gate input.
	DSM1CL <sup>(1)</sup>	TTL/ST	—	Data Signal Modulator 1 low carrier input.
	DSM2CL <sup>(1)</sup>	TTL/ST	—	Data Signal Modulator 2 low carrier input.
	OSC2	—	XTAL	Crystal/Resonator (LP, XT, HS modes).
RA5/T1CKI/T2IN/CLCIN3/ DSM1MOD/DSM2MOD/ SOSCI/OSC1/CLKIN	RA5	TTL/ST	CMOS	General purpose I/O.
	T1CKI <sup>(1)</sup>	TTL/ST	—	Timer1 clock input.
	T2IN <sup>(1)</sup>	TTL/ST	—	Timer2 clock input.
	CLCIN3 <sup>(1)</sup>	TTL/ST	—	CLC Input 3.
	DSM1MOD <sup>(1)</sup>	TTL/ST	—	Data Signal Modulator 1 modulation input.
	DSM2MOD <sup>(1)</sup>	TTL/ST	—	Data Signal Modulator 2 modulation input.
	SOSCI	XTAL	—	Secondary Oscillator connection.
	OSC1	XTAL	—	Crystal/Resonator (LP, XT, HS modes).
RB4/AN10/OPA1IN0-/SDI/SDA	RB4	TTL/ST	CMOS	General purpose I/O.
	AN10	AN	—	ADC Channel 10 input.
	OPA1IN0-	AN	—	Operational Amplifier 1 inverting input.
	SDI <sup>(1)</sup>	TTL/ST	—	SPI data input.
	SDA <sup>(1,3)</sup>	I <sup>2</sup> C	—	I <sup>2</sup> C data output.
RB5/AN11/OPA1IN0+/RX	RB5	TTL/ST	CMOS	General purpose I/O.
	AN11	AN	—	ADC Channel 11 input.
	OPA1IN0+	AN	—	Operational Amplifier 1 noninverting input.
	RX <sup>(1,3)</sup>	TTL/ST	—	EUSART receive input.
RB6/C1IN1+/C3IN1+/SCK/SCL	RB6	TTL/ST	CMOS	General purpose I/O.
	C1IN1+	AN	—	Comparator C1 positive input.
	C3IN1+	AN	—	Comparator C3 positive input.
	SCK <sup>(1)</sup>	TTL/ST	—	SPI clock input.
RB7/C2IN1+/C4IN1+/CK	RB7	TTL/ST	CMOS	General purpose I/O.
	C2IN1+	AN	—	Comparator C2 positive input.
	C4IN1+	AN	—	Comparator C4 positive input.
	CK <sup>(1)</sup>	TTL/ST	—	EUSART clock input.
RC0/AN4/C2IN0+/C4IN0+/ T5CKI	RC0	TTL/ST	CMOS	General purpose I/O.
	AN4	AN	—	ADC Channel 4 input.
	C2IN0+	AN	—	Comparator C2 positive input.
	C4IN0+	AN	—	Comparator C4 positive input.
T5CKI <sup>(1)</sup>	T5CKI <sup>(1)</sup>	TTL/ST	—	Timer5 clock input.

**Legend:** AN = Analog input or output    CMOS = CMOS compatible input or output    OD = Open-Drain  
TTL = TTL compatible input    ST = Schmitt Trigger input with CMOS levels    I<sup>2</sup>C = Schmitt Trigger input with I<sup>2</sup>C  
HV = High Voltage    XTAL = Crystal levels

- Note 1:** Default peripheral input. Alternate pins can be selected as the peripheral input with the PPS Input Selection registers.  
**Note 2:** All pin digital outputs default to PORT latch data. Alternate outputs can be selected as peripheral digital outputs with the PPS Output Selection registers.  
**Note 3:** These peripheral functions are bidirectional. The output pin selections must be the same as the input pin selections.

# PIC16(L)F1764/5/8/9

**TABLE 1-3: PIC16(L)F1768/9 PINOUT DESCRIPTION (CONTINUED)**

Name	Function	Input Type	Output Type	Description
RC1/AN5/C1IN1-/C2IN1-/C3IN1-/C4IN1-/T4IN/CLCIN2	RC1	TTL/ST	CMOS	General purpose I/O.
	AN5	AN	XTAL	ADC Channel 5 input.
	C1IN1-	AN	—	Comparator 1 negative input.
	C2IN1-	AN	—	Comparator 2 negative input.
	C3IN1-	AN	—	Comparator 3 negative input.
	C4IN1-	AN	—	Comparator 4 negative input.
	T4IN <sup>(1)</sup>	TTL/ST	—	Timer4 clock input.
	CLCIN2 <sup>(1)</sup>	TTL/ST	—	CLC Input 2.
RC2/AN6/OPA1OUT/OPA2IN1-/OPA2IN1+/C1IN2-/C2IN2-/PRG1IN0/PRG2IN1	RC2	TTL/ST	CMOS	General purpose I/O.
	AN6	AN	—	ADC Channel 6 input.
	OPA1OUT	—	AN	Operational Amplifier 1 output.
	OPA2IN1-	AN	—	Operational Amplifier 2 inverting input.
	OPA2IN1+	AN	—	Operational Amplifier 2 noninverting input.
	C1IN2-	AN	—	Comparator 1 negative input.
	C2IN2-	AN	—	Comparator 2 negative input.
	PRG1IN0	AN	—	Ramp Generator 1 reference voltage input.
	PRG2IN1	AN	—	Ramp Generator 2 reference voltage input.
RC3/AN7/OPA2OUT/OPA1IN1-/OPA1IN1+/C1IN3-/C2IN3-/C3IN3-/C4IN3-/PRG1IN1/PRG2IN0/T5G/CCP2/CLCIN0	RC3	TTL/ST	CMOS	General purpose I/O.
	AN7	AN	—	ADC Channel 7 input.
	OPA2OUT	—	AN	Operational Amplifier 2 output.
	OPA1IN1-	AN	—	Operational Amplifier 1 inverting input.
	OPA1IN1+	AN	—	Operational Amplifier 1 noninverting input.
	C1IN3-	AN	—	Comparator 1 negative input.
	C2IN3-	AN	—	Comparator 2 negative input.
	C3IN3-	AN	—	Comparator 3 negative input.
	C4IN3-	AN	—	Comparator 4 negative input.
	PRG1IN1	AN	—	Ramp Generator 1 reference voltage input.
	PRG2IN0	AN	—	Ramp Generator 2 reference voltage input.
	T5G <sup>(1)</sup>	TTL/ST	—	Timer5 gate input.
	CCP2 <sup>(1)</sup>	TTL/ST	—	CCP2 capture input.
		CLCIN0 <sup>(1)</sup>	TTL/ST	—
RC4/T3G/PRG1R/PRG2R/CLCIN1	RC4	TTL/ST	CMOS	General purpose I/O.
	T3G <sup>(1)</sup>	TTL/ST	—	Timer3 gate input.
	PRG1R <sup>(1)</sup>	TTL/ST	—	Ramp Generator 1 set_rising input.
	PRG2R <sup>(1)</sup>	TTL/ST	—	Ramp Generator 2 set_rising input.
		CLCIN1 <sup>(1)</sup>	TTL/ST	—
RC5/T3CKI/PRG1F/PRG2F/CCP1	RC5	TTL/ST	CMOS	General purpose I/O.
	T3CKI <sup>(1)</sup>	TTL/ST	—	Timer3 clock input.
	PRG1F <sup>(1)</sup>	TTL/ST	—	Ramp Generator 1 set_falling input.
	PRG2F <sup>(1)</sup>	TTL/ST	—	Ramp Generator 2 set_falling input.
		CCP1 <sup>(1)</sup>	TTL/ST	—

**Legend:** AN = Analog input or output    CMOS = CMOS compatible input or output    OD = Open-Drain  
TTL = TTL compatible input    ST = Schmitt Trigger input with CMOS levels    I<sup>2</sup>C = Schmitt Trigger input with I<sup>2</sup>C  
HV = High Voltage    XTAL = Crystal levels

- Note 1:** Default peripheral input. Alternate pins can be selected as the peripheral input with the PPS Input Selection registers.  
**Note 2:** All pin digital outputs default to PORT latch data. Alternate outputs can be selected as peripheral digital outputs with the PPS Output Selection registers.  
**Note 3:** These peripheral functions are bidirectional. The output pin selections must be the same as the input pin selections.

# PIC16(L)F1764/5/8/9

**TABLE 1-3: PIC16(L)F1768/9 PINOUT DESCRIPTION (CONTINUED)**

Name	Function	Input Type	Output Type	Description
RC6/AN8/OPA2IN0- $\overline{SS}$	RC6	TTL/ST	CMOS	General purpose I/O.
	AN8	AN	—	ADC Channel 8 input.
	OPA2IN0-	AN	—	Operational Amplifier 2 inverting input.
	$\overline{SS}^{(1)}$	TTL/ST	—	SPI Slave Select input.
RC7/AN9/OPA2IN0+	RC7	TTL/ST	CMOS	General purpose I/O.
	AN9	AN	—	ADC Channel 9 input.
	OPA2IN0+	AN	—	Operational Amplifier 2 noninverting input.
VDD	VDD	Power	—	Positive supply.
VSS	VSS	Power	—	Ground reference.
OUT <sup>(2)</sup>	C1OUT		CMOS	Comparator 1 output.
	C2OUT		CMOS	Comparator 2 output.
	C3OUT		CMOS	Comparator 3 output.
	C4OUT		CMOS	Comparator 4 output.
	CCP1		CMOS	Compare/PWM1 output.
	CCP2		CMOS	Compare/PWM2 output.
	MD1OUT		CMOS	Data Signal Modulator 1 output.
	MD2OUT		CMOS	Data Signal Modulator 2 output.
	PWM3		CMOS	PWM3 output.
	PWM4		CMOS	PWM4 output.
	PWM5		CMOS	PWM5 output.
	PWM6		CMOS	PWM6 output.
	COG1A		CMOS	Complementary Output Generator 1 Output A.
	COG1B		CMOS	Complementary Output Generator 1 Output B.
	COG1C		CMOS	Complementary Output Generator 1 Output C.
	COG1D		CMOS	Complementary Output Generator 1 Output D.
	COG2A		CMOS	Complementary Output Generator 2 Output A.
	COG2B		CMOS	Complementary Output Generator 2 Output B.
	COG2C		CMOS	Complementary Output Generator 2 Output C.
	COG2D		CMOS	Complementary Output Generator 2 Output D.
	SDA <sup>(3)</sup>		OD	I <sup>2</sup> C data output.
	SCK		CMOS	SPI clock output.
	SCL <sup>(3)</sup>		OD	I <sup>2</sup> C clock output.
	SDO		CMOS	SPI data output.
	TX		CMOS	EUSART asynchronous TX data out.
	CK		CMOS	EUSART synchronous clock out.
	DT <sup>(3)</sup>		CMOS	EUSART synchronous data output.
	CLC1OUT		CMOS	Configurable Logic Cell 1 output.
	CLC2OUT		CMOS	Configurable Logic Cell 2 output.
	CLC3OUT		CMOS	Configurable Logic Cell 3 output.

**Legend:** AN = Analog input or output    CMOS = CMOS compatible input or output    OD = Open-Drain  
TTL = TTL compatible input    ST = Schmitt Trigger input with CMOS levels    I<sup>2</sup>C = Schmitt Trigger input with I<sup>2</sup>C  
HV = High Voltage    XTAL = Crystal levels

- Note 1:** Default peripheral input. Alternate pins can be selected as the peripheral input with the PPS Input Selection registers.  
**Note 2:** All pin digital outputs default to PORT latch data. Alternate outputs can be selected as peripheral digital outputs with the PPS Output Selection registers.  
**Note 3:** These peripheral functions are bidirectional. The output pin selections must be the same as the input pin selections.

# PIC16(L)F1764/5/8/9

## 1.2 Peripheral Connection Matrix

Input selection multiplexers on many of the peripherals enable selecting the output of another peripheral, such that the signal path is contained entirely within the device. Although the peripheral output can also be

routed to a pin with the PPS selection feature, it is not necessary to do so. Table 1-4 shows all the possible inter-peripheral signal connections. Please refer to the corresponding peripheral section to obtain the multiplexer selection codes for the desired connection.

**TABLE 1-4: PERIPHERAL CONNECTION MATRIX**

Peripheral Output	Peripheral Input																									
	ADC Trigger	COG Clock	COG Rising/Falling	COG Shutdown	10-Bit DAC	5-Bit DAC	PRG Analog Input	PRG Rising/Falling	Comparator +	Comparator -	CLC	DSM CH	DSM CL	DSM Mod	Op Amp +	Op Amp -	Op Amp Override	10-Bit PWM	16-Bit PWM	CCP Capture	CCP Clock	Timer2/4/6 Clock	Timer2/4/6 Reset	Timer1/3/5 Gate	Timer0 Clock	
FVR					•	•	•		•	•					•	•										
ZCD											•						•						•			
PRG									•	•					•	•										
10-Bit DAC							•		•	•					•	•										
5-Bit DAC							•		•	•					•	•										
CCP	•		•					•			•	•	•	•			•							•		
Comparator (sync)	•							•			•	•	•	•			•			•			•	•		
Comparator (async)			•	•										•												
CLC	•		•	•							•	•	•	•			•			•		•	•			
DSM																										
COG																	•									
EUSART TX/CK											•				•											
EUSART DT											•				•											
MSSP SCK/SCL											•				•											
MSSP SDO/SDA											•				•											
Op Amp							•																			
10-Bit PWM	•		•					•			•	•	•	•			•							•		
16-Bit PWM	•		•					•			•	•	•	•			•							•		
Timer0 Overflow	•										•														•	
Timer2 = T2PR				•							•							•				•		•		
Timer4 = T4PR				•							•							•				•		•		
Timer6 = T6PR				•							•							•				•		•		
Timer2 Postscale	•			•							•							•				•		•		
Timer4 Postscale	•			•							•							•				•		•		
Timer6 Postscale	•			•							•							•				•		•		
Timer1 Overflow	•										•							•				•		•		
Timer3 Overflow	•										•							•				•		•		
Timer5 Overflow	•										•							•				•		•		
SOSC																			•				•			
Fosc/4		•																					•			
Fosc		•									•	•	•						•				•			
HFINTOSC		•									•	•	•						•				•			
LFINTOSC											•								•				•			
MFINTOSC																							•			
IOCIF											•									•	•					
PPS Input Pin			•	•				•				•	•	•						•	•		•	•	•	•

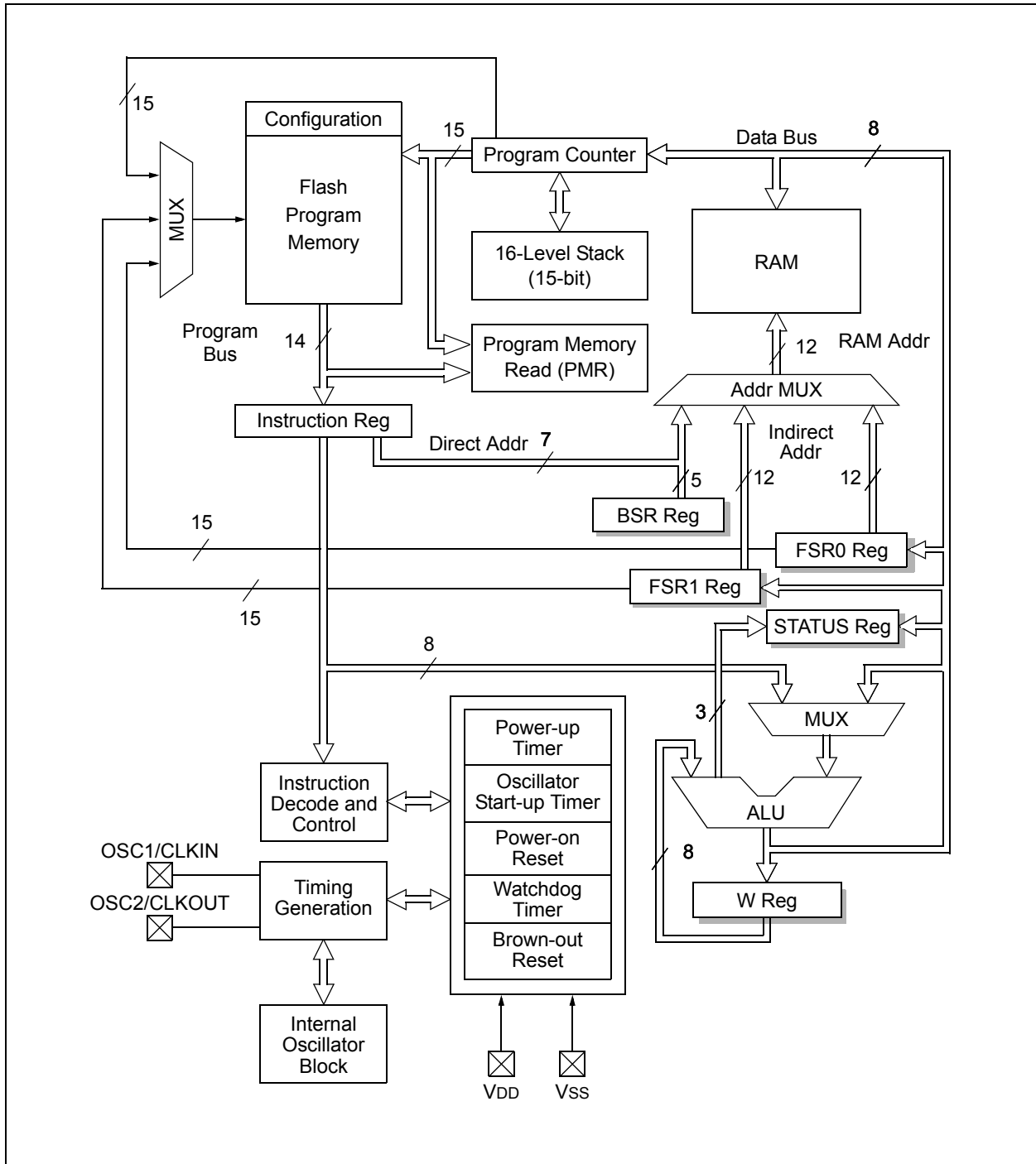
## 2.0 ENHANCED MID-RANGE CPU

This family of devices contains an enhanced mid-range 8-bit CPU core. The CPU has 49 instructions. Interrupt capability includes automatic context saving. The hardware stack is 16 levels deep and has Overflow and Underflow Reset capability. Direct, Indirect and

Relative Addressing modes are available. Two File Select Registers (FSRs) provide the ability to read program and data memory.

- Automatic Interrupt Context Saving
- 16-Level Stack with Overflow and Underflow
- File Select Registers
- Instruction Set

**FIGURE 2-1: CORE BLOCK DIAGRAM**



## 2.1 Automatic Interrupt Context Saving

During interrupts, certain registers are automatically saved in shadow registers and restored when returning from the interrupt. This saves stack space and user code. See [Section 7.5 “Automatic Context Saving”](#) for more information.

## 2.2 16-Level Stack with Overflow and Underflow

These devices have a hardware stack memory 15 bits wide and 16 words deep. A Stack Overflow or Underflow will set the appropriate bit (STKOVF or STKUNF) in the PCON register, and if enabled, will cause a Software Reset. See [Section 3.5 “Stack”](#) for more details.

## 2.3 File Select Registers

There are two 16-bit File Select Registers (FSRs). FSRs can access all file registers and program memory, which allows one Data Pointer for all memory. When an FSR<sub>n</sub> points to program memory, there is one additional instruction cycle in instructions using INDF<sub>n</sub> to allow the data to be fetched. General purpose memory can now also be addressed linearly, providing the ability to access contiguous data larger than 80 bytes. There are also new instructions to support the FSRs. See [Section 3.6 “Indirect Addressing”](#) for more details.

## 2.4 Instruction Set

There are 49 instructions for the enhanced mid-range CPU to support the features of the CPU. See [Section 35.0 “Instruction Set Summary”](#) for more details.

## 3.0 MEMORY ORGANIZATION

These devices contain the following types of memory:

- Program Memory:
  - Configuration Words
  - Device ID
  - User ID
  - Flash Program Memory
- Data Memory:
  - Core Registers
  - Special Function Registers
  - General Purpose RAM
  - Common RAM

**Note 1:** The method to access Flash memory through the PMCON registers is described in **Section 10.0 “Flash Program Memory Control”**.

The following features are associated with access and control of program memory and data memory:

- PCL and PCLATH
- Stack
- Indirect Addressing

## 3.1 Program Memory Organization

The enhanced mid-range core has a 15-bit Program Counter (PC) capable of addressing a 32K x 14 program memory space. [Table 3-1](#) shows the memory sizes implemented for the PIC16(L)F1764/5/8/9 family. Accessing a location above these boundaries will cause a wrap around within the implemented memory space. The Reset vector is at 0000h and the interrupt vector is at 0004h (see [Figure 3-1](#)).

## 3.2 High-Endurance Flash

This device has a 128-byte section of high-endurance Program Flash Memory (PFM) in lieu of data EEPROM. This area is especially well suited for nonvolatile data storage that is expected to be updated frequently over the life of the end product. See **Section 10.2 “Flash Program Memory Overview”** for more information on writing data to PFM. See **Section 3.2.1.2 “Indirect Read with FSRn”** for more information about using the FSRn registers to read byte data stored in PFM.

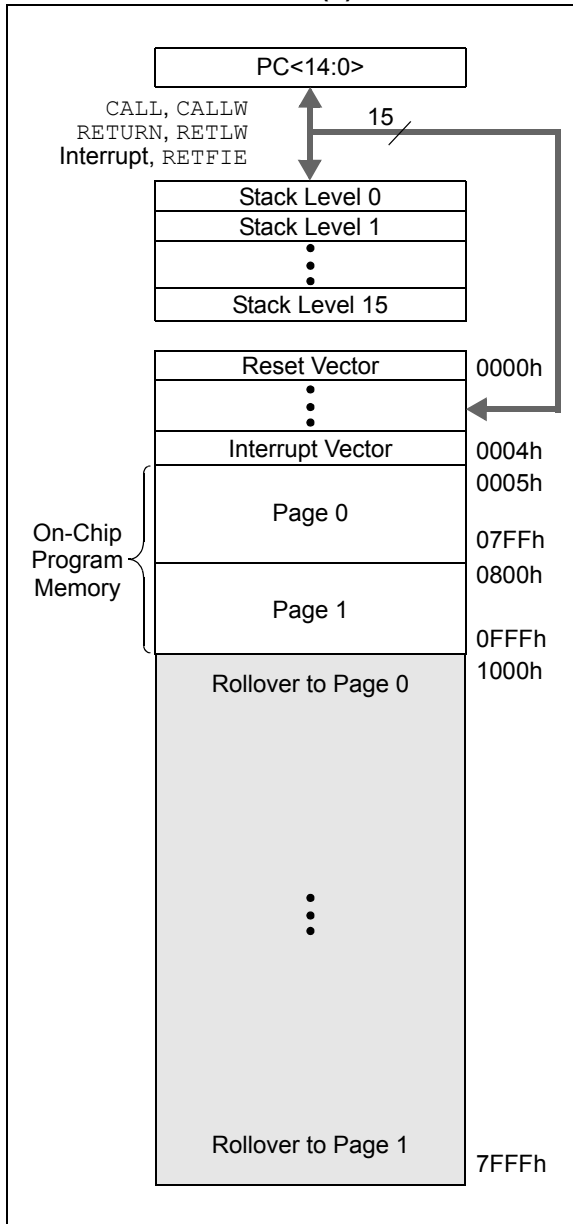
**TABLE 3-1: DEVICE SIZES AND ADDRESSES**

Device	Program Memory Space (Words)	Last Program Memory Address	High-Endurance Flash Memory Address Range <sup>(1)</sup>
PIC16(L)F1764	4,096	0FFFh	0F80h-0FFFh
PIC16(L)F1765	8,192	1FFFh	1F80h-1FFFh
PIC16(L)F1768	4,096	0FFFh	0F80h-0FFFh
PIC16(L)F1769	8,192	1FFFh	1F80h-1FFFh

**Note 1:** High-endurance Flash applies to the low byte of each address in the range.



**FIGURE 3-1: PROGRAM MEMORY MAP AND STACK FOR PIC16(L)F1764/5/8/9**



## 3.2.1 READING PROGRAM MEMORY AS DATA

There are two methods of accessing constants in program memory. The first method is to use tables of `RETLW` instructions. The second method is to set an `FSRn` to point to the program memory.

### 3.2.1.1 RETLW Instruction

The `RETLW` instruction can be used to provide access to tables of constants. The recommended way to create such a table is shown in [Example 3-1](#).

#### EXAMPLE 3-1: RETLW INSTRUCTION

```
constants
    BRW                ;Add Index in W to
                       ;program counter to
                       ;select data

    RETLW DATA0       ;Index0 data
    RETLW DATA1       ;Index1 data
    RETLW DATA2
    RETLW DATA3

my_function
    ;... LOTS OF CODE...
    MOVLW DATA_INDEX
    call constants
    ;... THE CONSTANT IS IN W
```

The `BRW` instruction makes this type of table very simple to implement. If your code must remain portable with previous generations of microcontrollers, then the `BRW` instruction is not available, so the older table read method must be used.

### 3.2.1.2 Indirect Read with `FSRn`

The program memory can be accessed as data by setting bit 7 of the `FSRnH` register and reading the matching `INDFn` register. The `MOVIW` instruction will place the lower eight bits of the addressed word in the `W` register. Writes to the program memory cannot be performed via the `INDFn` registers. Instructions that access the program memory via the `FSRn` require one extra instruction cycle to complete. [Example 3-2](#) demonstrates accessing the program memory via an `FSRn`.

The high directive will set bit 7 if a label points to a location in program memory.

## EXAMPLE 3-2: ACCESSING PROGRAM MEMORY VIA FSRn

```

constants
  DW DATA0          ;First constant
  DW DATA1          ;Second constant
  DW DATA2
  DW DATA3
my_function
  ;... LOTS OF CODE...
  MOVLW DATA_INDEX
  ADDLW LOW constants
  MOVWF FSR1L
  MOVLW HIGH constants ;MSb sets
                        automatically
  MOVWF FSR1H
  BTFSC STATUS, C      ;carry from ADDLW?
  INCF FSR1H, f        ;yes
  MOVIW 0[FSR1]
;THE PROGRAM MEMORY IS IN W
    
```

## 3.3 Data Memory Organization

The data memory is partitioned in 32 memory banks with 128 bytes in a bank. Each bank consists of (Figure 3-2):

- 12 core registers
- 20 Special Function Registers (SFRs)
- Up to 80 bytes of General Purpose RAM (GPR)
- 16 bytes of common RAM

The active bank is selected by writing the bank number into the Bank Select Register (BSR). Unimplemented memory will read as '0'. All data memory can be accessed either directly (via instructions that use the file registers) or indirectly via the two File Select Registers (FSRs). See [Section 3.6 "Indirect Addressing"](#) for more information.

Data memory uses a 12-bit address. The upper five bits of the address define the Bank address and the lower seven bits select the registers/RAM in that bank.

### 3.3.1 CORE REGISTERS

The core registers contain the registers that directly affect the basic operation. The core registers occupy the first 12 addresses of every data memory bank (addresses, x00h/x08h through x0Bh/x8Bh). These registers are listed below in [Table 3-2](#). For detailed information, see [Table 3-15](#).

TABLE 3-2: CORE REGISTERS

Addresses	BANKx
x00h or x80h	INDF0
x01h or x81h	INDF1
x02h or x82h	PCL
x03h or x83h	STATUS
x04h or x84h	FSR0L
x05h or x85h	FSR0H
x06h or x86h	FSR1L
x07h or x87h	FSR1H
x08h or x88h	BSR
x09h or x89h	WREG
x0Ah or x8Ah	PCLATH
x0Bh or x8Bh	INTCON

#### 3.3.1.1 STATUS Register

The STATUS register, shown in [Register 3-1](#), contains:

- The arithmetic status of the ALU
- The Reset status

The STATUS register can be the destination for any instruction, like any other register. If the STATUS register is the destination for an instruction that affects the Z, DC or C bits, then the write to these three bits is disabled. These bits are set or cleared according to the device logic. Furthermore, the TO and PD bits are not writable. Therefore, the result of an instruction with the STATUS register as destination may be different than intended.

For example, `CLRF STATUS` will clear the upper three bits and set the Z bit. This leaves the STATUS register as '000u u1uu' (where u = unchanged).

It is recommended, therefore, that only `BCE`, `BSF`, `SWAPF` and `MOVWF` instructions are used to alter the STATUS register, because these instructions do not affect any Status bits. For other instructions not affecting any Status bits, refer to [Section 35.0 "Instruction Set Summary"](#).

**Note:** The C and DC bits operate as Borrow and Digit Borrow out bits, respectively, in subtraction.

# PIC16(L)F1764/5/8/9

## REGISTER 3-1: STATUS: STATUS REGISTER

U-0	U-0	U-0	R-1/q	R-1/q	R/W-0/u	R/W-0/u	R/W-0/u	
—	—	—	$\overline{\text{TO}}$	$\overline{\text{PD}}$	Z	DC <sup>(1)</sup>	C <sup>(1)</sup>	
bit 7								bit 0

### Legend:

R = Readable bit

W = Writable bit

U = Unimplemented bit, read as '0'

u = Bit is unchanged

x = Bit is unknown

-n/n = Value at POR and BOR/Value at all other Resets

'1' = Bit is set

'0' = Bit is cleared

q = Value depends on condition

bit 7-5 **Unimplemented:** Read as '0'

bit 4 **TO:** Time-out bit

1 = After power-up, CLRWD $\overline{\text{T}}$  instruction or SLEEP instruction

0 = A WDT time-out occurred

bit 3 **PD:** Power-Down bit

1 = After power-up or by the CLRWD $\overline{\text{T}}$  instruction

0 = By execution of the SLEEP instruction

bit 2 **Z:** Zero bit

1 = The result of an arithmetic or logic operation is zero

0 = The result of an arithmetic or logic operation is not zero

bit 1 **DC:** Digit Carry/Digit Borrow bit (ADDWF, ADDLW, SUBLW, SUBWF instructions)<sup>(1)</sup>

1 = A carry-out from the 4th low-order bit of the result occurred

0 = No carry-out from the 4th low-order bit of the result

bit 0 **C:** Carry/Borrow bit<sup>(1)</sup> (ADDWF, ADDLW, SUBLW, SUBWF instructions)<sup>(1)</sup>

1 = A carry-out from the Most Significant bit of the result occurred

0 = No carry-out from the Most Significant bit of the result occurred

**Note 1:** For Borrow, the polarity is reversed. A subtraction is executed by adding the two's complement of the second operand.

### 3.3.2 SPECIAL FUNCTION REGISTER

The Special Function Registers (SFRs) are registers used by the application to control the desired operation of peripheral functions in the device. The SFR occupies the 20 bytes after the core registers of every data memory bank (addresses, x0Ch/x8Ch through x1Fh/x9Fh). The registers associated with the operation of each peripheral are described in the corresponding peripheral chapters of this data sheet.

### 3.3.3 GENERAL PURPOSE RAM

There are up to 80 bytes of General Purpose Registers (GPRs) in each data memory bank. The GPR occupies the space immediately after the SFR of selected data memory banks. The number of banks selected depends on the total amount of GPR space available in the device.

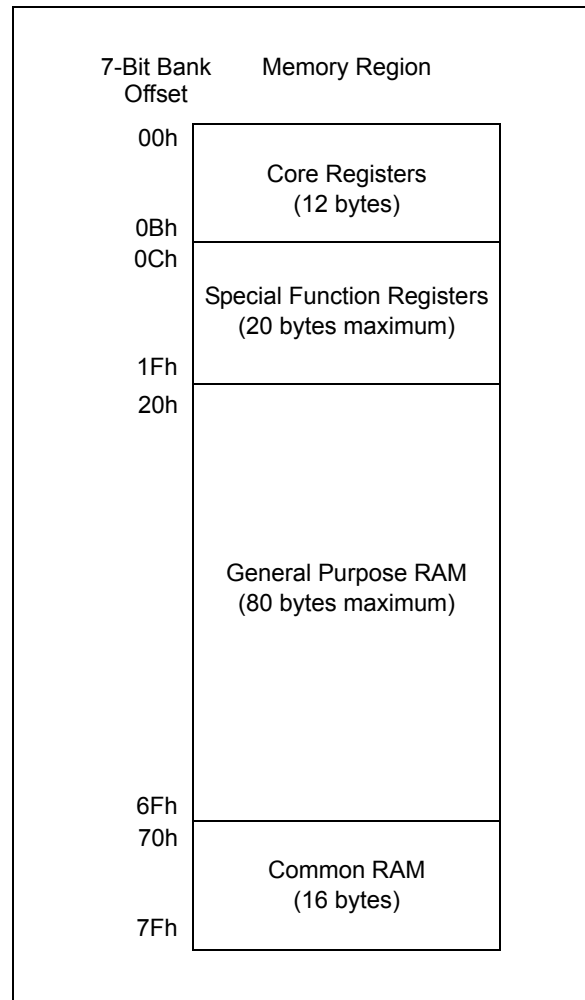
#### 3.3.3.1 Linear Access to GPR

The general purpose RAM can be accessed in a non-banked method via the FSRs. This can simplify access to large memory structures. See [Section 3.6.2 “Linear Data Memory”](#) for more information.

### 3.3.4 COMMON RAM

There are 16 bytes of common RAM accessible from all banks.

**FIGURE 3-2: BANKED MEMORY PARTITIONING**



### 3.3.5 DEVICE MEMORY MAPS

The memory maps for the device family are shown in [Tables 3-3 through 3-14](#).

TABLE 3-3: PIC16(L)F1764 MEMORY MAP (BANKS 0-7)

BANK 0		BANK 1		BANK 2		BANK 3		BANK 4		BANK 5		BANK 6		BANK 7	
000h	Core Registers (Table 3-2)	080h	Core Registers (Table 3-2)	100h	Core Registers (Table 3-2)	180h	Core Registers (Table 3-2)	200h	Core Registers (Table 3-2)	280h	Core Registers (Table 3-2)	300h	Core Registers (Table 3-2)	380h	Core Registers (Table 3-2)
00Bh		08Bh		10Bh		18Bh		20Bh		28Bh		30Bh		38Bh	
00Ch	PORTA	08Ch	TRISA	10Ch	LATA	18Ch	ANSELA	20Ch	WPUA	28Ch	ODCONA	30Ch	SLRCONA	38Ch	INLVLA
00Dh	—	08Dh	—	10Dh	—	18Dh	—	20Dh	—	28Dh	—	30Dh	—	38Dh	—
00Eh	PORTC	08Eh	TRISC	10Eh	LATC	18Eh	ANSELC	20Eh	WPUC	28Eh	ODCONC	30Eh	SLRCONC	38Eh	INLVLC
00Fh	—	08Fh	—	10Fh	CMOUT	18Fh	—	20Fh	—	28Fh	—	30Fh	—	38Fh	—
010h	—	090h	—	110h	CM1CON0	190h	—	210h	—	290h	—	310h	—	390h	—
011h	PIR1	091h	PIE1	111h	CM1CON1	191h	PMADRL	211h	SSP1BUF	291h	CCPR1L	311h	—	391h	IOCAP
012h	PIR2	092h	PIE2	112h	CM1NSEL	192h	PMADRH	212h	SSP1ADD	292h	CCPR1H	312h	—	392h	IOCAN
013h	PIR3	093h	PIE3	113h	CM1PSEL	193h	PMDATL	213h	SSP1MSK	293h	CCP1CON	313h	—	393h	IOCAF
014h	PIR4	094h	PIE4	114h	CM2CON0	194h	PMDATH	214h	SSP1STAT	294h	CCP1CAP	314h	—	394h	—
015h	TMR0	095h	OPTION_REG	115h	CM2CON1	195h	PMCON1	215h	SSP1CON1	295h	—	315h	—	395h	—
016h	TMR1L	096h	PCON	116h	CM2NSEL	196h	PMCON2	216h	SSP1CON2	296h	—	316h	—	396h	—
017h	TMR1H	097h	WDTCN	117h	CM2PSEL	197h	VREGCON <sup>(1)</sup>	217h	SSP1CON3	297h	—	317h	—	397h	IOCCP
018h	T1CON	098h	OSCTUNE	118h	—	198h	—	218h	—	298h	—	318h	—	398h	IOCCN
019h	T1GCON	099h	OSCCON	119h	—	199h	RC1REG	219h	—	299h	—	319h	—	399h	IOCCF
01Ah	T2TMR	09Ah	OSCSTAT	11Ah	—	19Ah	TX1REG	21Ah	—	29Ah	—	31Ah	—	39Ah	—
01Bh	T2PR	09Bh	ADRESL	11Bh	—	19Bh	SP1BRGL	21Bh	—	29Bh	—	31Bh	—	39Bh	MD1CON0
01Ch	T2CON	09Ch	ADRESH	11Ch	—	19Ch	SP1BRGH	21Ch	—	29Ch	—	31Ch	—	39Ch	MD1CON1
01Dh	T2HLT	09Dh	ADCON0	11Dh	—	19Dh	RC1STA	21Dh	BORCON	29Dh	—	31Dh	—	39Dh	MD1SRC
01Eh	T2CLKCON	09Eh	ADCON1	11Eh	—	19Eh	TX1STA	21Eh	FVRCON	29Eh	CCPTMRS	31Eh	—	39Eh	MD1CARL
01Fh	T2RST	09Fh	ADCON2	11Fh	—	19Fh	BAUD1CON	21Fh	ZCD1CON	29Fh	—	31Fh	—	39Fh	MD1CARH
020h		0A0h		120h		1A0h		220h		2A0h		320h	General Purpose Register 16 Bytes	3A0h	
	General Purpose Register 80 Bytes		General Purpose Register 80 Bytes		General Purpose Register 80 Bytes		General Purpose Register 80 Bytes		General Purpose Register 80 Bytes		General Purpose Register 80 Bytes	32Fh			
												330h	Unimplemented Read as '0'		Unimplemented Read as '0'
06Fh		0EFh		16Fh		1EFh		26Fh		2EFh		36Fh		3EFh	
070h	Common RAM 70h-7Fh	0F0h	Accesses 70h-7Fh	170h	Accesses 70h-7Fh	1F0h	Accesses 70h-7Fh	270h	Accesses 70h-7Fh	2F0h	Accesses 70h-7Fh	370h	Accesses 70h-7Fh	3F0h	Accesses 70h-7Fh
07Fh		0FFh		17Fh		1FFh		27Fh		2FFh		37Fh		3FFh	

Legend: □ = Unimplemented data memory locations, read as '0'.

Note 1: Unimplemented on PIC16LF1764.

**TABLE 3-4: PIC16LF1765 MEMORY MAP (BANKS 0-7)**

BANK 0		BANK 1		BANK 2		BANK 3		BANK 4		BANK 5		BANK 6		BANK 7	
000h	Core Registers (Table 3-2)	080h	Core Registers (Table 3-2)	100h	Core Registers (Table 3-2)	180h	Core Registers (Table 3-2)	200h	Core Registers (Table 3-2)	280h	Core Registers (Table 3-2)	300h	Core Registers (Table 3-2)	380h	Core Registers (Table 3-2)
00Bh		08Bh		10Bh		18Bh		20Bh		28Bh		30Bh		38Bh	
00Ch	PORTA	08Ch	TRISA	10Ch	LATA	18Ch	ANSELA	20Ch	WPUA	28Ch	ODCONA	30Ch	SLRCONA	38Ch	INLVLA
00Dh	—	08Dh	—	10Dh	—	18Dh	—	20Dh	—	28Dh	—	30Dh	—	38Dh	—
00Eh	PORTC	08Eh	TRISC	10Eh	LATC	18Eh	ANSELC	20Eh	WPUC	28Eh	ODCONC	30Eh	SLRCONC	38Eh	INLVLC
00Fh	—	08Fh	—	10Fh	CMOUT	18Fh	—	20Fh	—	28Fh	—	30Fh	—	38Fh	—
010h	—	090h	—	110h	CM1CON0	190h	—	210h	—	290h	—	310h	—	390h	—
011h	PIR1	091h	PIE1	111h	CM1CON1	191h	PMADRL	211h	SSP1BUF	291h	CCPR1L	311h	—	391h	IOCAP
012h	PIR2	092h	PIE2	112h	CM1NSEL	192h	PMADRH	212h	SSP1ADD	292h	CCPR1H	312h	—	392h	IOCAN
013h	PIR3	093h	PIE3	113h	CM1PSEL	193h	PMDATL	213h	SSP1MSK	293h	CCP1CON	313h	—	393h	IOCAF
014h	PIR4	094h	PIE4	114h	CM2CON0	194h	PMDATH	214h	SSP1STAT	294h	CCP1CAP	314h	—	394h	—
015h	TMR0	095h	OPTION_REG	115h	CM2CON1	195h	PMCON1	215h	SSP1CON	295h	—	315h	—	395h	—
016h	TMR1L	096h	PCON	116h	CM2NSEL	196h	PMCON2	216h	SSP1CON2	296h	—	316h	—	396h	—
017h	TMR1H	097h	WDTCN	117h	CM2PSEL	197h	VREGCON <sup>(1)</sup>	217h	SSP1CON3	297h	—	317h	—	397h	IOCCP
018h	T1CON	098h	OSCTUNE	118h	—	198h	—	218h	—	298h	—	318h	—	398h	IOCCN
019h	T1GCON	099h	OSCCON	119h	—	199h	RC1REG	219h	—	299h	—	319h	—	399h	IOCCF
01Ah	T2TMR	09Ah	OSCSTAT	11Ah	—	19Ah	TX1REG	21Ah	—	29Ah	—	31Ah	—	39Ah	—
01Bh	T2PR	09Bh	ADRESL	11Bh	—	19Bh	SP1BRGL	21Bh	—	29Bh	—	31Bh	—	39Bh	MD1CON0
01Ch	T2CON	09Ch	ADRESH	11Ch	—	19Ch	SP1BRGH	21Ch	—	29Ch	—	31Ch	—	39Ch	MD1CON1
01Dh	T2HLT	09Dh	ADCON0	11Dh	—	19Dh	RC1STA	21Dh	BORCON	29Dh	—	31Dh	—	39Dh	MD1SRC
01Eh	T2CLKCON	09Eh	ADCON1	11Eh	—	19Eh	TX1STA	21Eh	FVRCON	29Eh	CCPTMRS	31Eh	—	39Eh	MD1CARL
01Fh	T2RST	09Fh	ADCON2	11Fh	—	19Fh	BAUD1CON	21Fh	ZCD1CON	29Fh	—	31Fh	—	39Fh	MD1CARH
020h	General Purpose Register 80 Bytes	0A0h	General Purpose Register 80 Bytes	120h	General Purpose Register 80 Bytes	1A0h	General Purpose Register 80 Bytes	220h	General Purpose Register 80 Bytes	2A0h	General Purpose Register 80 Bytes	320h	General Purpose Register 80 Bytes	3A0h	General Purpose Register 80 Bytes
06Fh		0EFh		16Fh		1EFh		26Fh		2EFh		36Fh		3EFh	
070h	Common RAM 70h-7Fh	0F0h	Accesses 70h-7Fh	170h	Accesses 70h-7Fh	1F0h	Accesses 70h-7Fh	270h	Accesses 70h-7Fh	2F0h	Accesses 70h-7Fh	370h	Accesses 70h-7Fh	3F0h	Accesses 70h-7Fh
07Fh		0FFh		17Fh		1FFh		27Fh		2FFh		37Fh		3FFh	

**Legend:** □ = Unimplemented data memory locations, read as '0'.

**Note 1:** Unimplemented on PIC16LF1765.

TABLE 3-5: PIC16(L)F1768 MEMORY MAP (BANKS 0-7)

BANK 0		BANK 1		BANK 2		BANK 3		BANK 4		BANK 5		BANK 6		BANK 7	
000h	Core Registers (Table 3-2)	080h	Core Registers (Table 3-2)	100h	Core Registers (Table 3-2)	180h	Core Registers (Table 3-2)	200h	Core Registers (Table 3-2)	280h	Core Registers (Table 3-2)	300h	Core Registers (Table 3-2)	380h	Core Registers (Table 3-2)
00Bh		08Bh		10Bh		18Bh		20Bh		28Bh		30Bh		38Bh	
00Ch	PORTA	08Ch	TRISA	10Ch	LATA	18Ch	ANSELA	20Ch	WPUA	28Ch	ODCONA	30Ch	SLRCONA	38Ch	INLVLA
00Dh	PORTB	08Dh	TRISB	10Dh	LATB	18Dh	ANSELB	20Dh	WPUB	28Dh	ODCONB	30Dh	SLRCONB	38Dh	INLVLB
00Eh	PORTC	08Eh	TRISC	10Eh	LATC	18Eh	ANSELC	20Eh	WPUC	28Eh	ODCONC	30Eh	SLRCONC	38Eh	INLVLC
00Fh	—	08Fh	—	10Fh	CMOUT	18Fh	—	20Fh	—	28Fh	—	30Fh	—	38Fh	—
010h	—	090h	—	110h	CM1CON0	190h	—	210h	—	290h	—	310h	—	390h	—
011h	PIR1	091h	PIE1	111h	CM1CON1	191h	PMADRL	211h	SSP1BUF	291h	CCPR1L	311h	—	391h	IOCAP
012h	PIR2	092h	PIE2	112h	CM1NSEL	192h	PMADRH	212h	SSP1ADD	292h	CCPR1H	312h	—	392h	IOCAN
013h	PIR3	093h	PIE3	113h	CM1PSEL	193h	PMDATL	213h	SSP1MSK	293h	CCP1CON	313h	—	393h	IOCAF
014h	PIR4	094h	PIE4	114h	CM2CON0	194h	PMDATH	214h	SSP1STAT	294h	CCP1CAP	314h	—	394h	IOCBP
015h	TMR0	095h	OPTION_REG	115h	CM2CON1	195h	PMCON1	215h	SSP1CON1	295h	—	315h	—	395h	IOCBN
016h	TMR1L	096h	PCON	116h	CM2NSEL	196h	PMCON2	216h	SSP1CON2	296h	—	316h	—	396h	IOCBF
017h	TMR1H	097h	WDTCN	117h	CM2PSEL	197h	VREGCON <sup>(1)</sup>	217h	SSP1CON3	297h	—	317h	—	397h	IOCCP
018h	T1CON	098h	OSCTUNE	118h	CM3CON0	198h	—	218h	—	298h	CCPR2L	318h	—	398h	IOCCN
019h	T1GCON	099h	OSCCON	119h	CM3CON1	199h	RC1REG	219h	—	299h	CCPR2H	319h	—	399h	IOCCF
01Ah	T2TMR	09Ah	OSCSTAT	11Ah	CM3NSEL	19Ah	TX1REG	21Ah	—	29Ah	CCP2CON	31Ah	—	39Ah	—
01Bh	T2PR	09Bh	ADRESL	11Bh	CM3PSEL	19Bh	SP1BRGL	21Bh	—	29Bh	CCP2CAP	31Bh	MD2CON0	39Bh	MD1CON0
01Ch	T2CON	09Ch	ADRESH	11Ch	CM4CON0	19Ch	SP1BRGH	21Ch	—	29Ch	—	31Ch	MD2CON1	39Ch	MD1CON1
01Dh	T2HLT	09Dh	ADCON0	11Dh	CM4CON1	19Dh	RC1STA	21Dh	BORCON	29Dh	—	31Dh	MD2SRC	39Dh	MD1SRC
01Eh	T2CLKCON	09Eh	ADCON1	11Eh	CM4NSEL	19Eh	TX1STA	21Eh	FVRCON	29Eh	CCPTMRS	31Eh	MD2CARL	39Eh	MD1CARL
01Fh	T2RST	09Fh	ADCON2	11Fh	CM4PSEL	19Fh	BAUD1CON	21Fh	ZCD1CON	29Fh	—	31Fh	MD2CARH	39Fh	MD1CARH
020h	General Purpose Register 80 Bytes	0A0h	General Purpose Register 80 Bytes	120h	General Purpose Register 80 Bytes	1A0h	General Purpose Register 80 Bytes	220h	General Purpose Register 80 Bytes	2A0h	General Purpose Register 80 Bytes	320h	General Purpose Register 16 Bytes	3A0h	Unimplemented Read as '0'
06Fh		0EFh		16Fh		1EFh		26Fh		2EFh		36Fh	Unimplemented Read as '0'		
070h	Common RAM 70h-7Fh	0F0h	Accesses 70h-7Fh	170h	Accesses 70h-7Fh	1F0h	Accesses 70h-7Fh	270h	Accesses 70h-7Fh	2F0h	Accesses 70h-7Fh	370h	Accesses 70h-7Fh	3F0h	Accesses 70h-7Fh
07Fh		0FFh		17Fh		1FFh		27Fh		2FFh		37Fh			

Legend: □ = Unimplemented data memory locations, read as '0'.

Note 1: Unimplemented on PIC16LF1768.

**TABLE 3-6: PIC16(L)F1769 MEMORY MAP (BANKS 0-7)**

BANK 0		BANK 1		BANK 2		BANK 3		BANK 4		BANK 5		BANK 6		BANK 7	
000h	Core Registers (Table 3-2)	080h	Core Registers (Table 3-2)	100h	Core Registers (Table 3-2)	180h	Core Registers (Table 3-2)	200h	Core Registers (Table 3-2)	280h	Core Registers (Table 3-2)	300h	Core Registers (Table 3-2)	380h	Core Registers (Table 3-2)
00Bh		08Bh		10Bh		18Bh		20Bh		28Bh		30Bh		38Bh	
00Ch	PORTA	08Ch	TRISA	10Ch	LATA	18Ch	ANSELA	20Ch	WPUA	28Ch	ODCONA	30Ch	SLRCONA	38Ch	INLVLA
00Dh	PORTB	08Dh	TRISB	10Dh	LATB	18Dh	ANSELB	20Dh	WPUB	28Dh	ODCONB	30Dh	SLRCONB	38Dh	INLVLB
00Eh	PORTC	08Eh	TRISC	10Eh	LATC	18Eh	ANSELC	20Eh	WPUC	28Eh	ODCONC	30Eh	SLRCONC	38Eh	INLVLC
00Fh	—	08Fh	—	10Fh	CMOUT	18Fh	—	20Fh	—	28Fh	—	30Fh	—	38Fh	—
010h	—	090h	—	110h	CM1CON0	190h	—	210h	—	290h	—	310h	—	390h	—
011h	PIR1	091h	PIE1	111h	CM1CON1	191h	PMADRL	211h	SSP1BUF	291h	CCPR1L	311h	—	391h	IOCAP
012h	PIR2	092h	PIE2	112h	CM1NSEL	192h	PMADRH	212h	SSP1ADD	292h	CCPR1H	312h	—	392h	IOCAN
013h	PIR3	093h	PIE3	113h	CM1PSEL	193h	PMDATL	213h	SSP1MSK	293h	CCP1CON	313h	—	393h	IOCAF
014h	PIR4	094h	PIE4	114h	CM2CON0	194h	PMDATH	214h	SSP1STAT	294h	CCP1CAP	314h	—	394h	IOCBP
015h	TMR0	095h	OPTION_REG	115h	CM2CON1	195h	PMCON1	215h	SSP1CON1	295h	—	315h	—	395h	IOCBN
016h	TMR1L	096h	PCON	116h	CM2NSEL	196h	PMCON2	216h	SSP1CON2	296h	—	316h	—	396h	IOCBF
017h	TMR1H	097h	WDTCON	117h	CM2PSEL	197h	VREGCON <sup>(1)</sup>	217h	SSP1CON3	297h	—	317h	—	397h	IOCCP
018h	T1CON	098h	OSCTUNE	118h	CM3CON0	198h	—	218h	—	298h	CCPR2L	318h	—	398h	IOCCN
019h	T1GCON	099h	OSCCON	119h	CM3CON1	199h	RC1REG	219h	—	299h	CCPR2H	319h	—	399h	IOCCF
01Ah	T2TMR	09Ah	OSCSTAT	11Ah	CM3NSEL	19Ah	TX1REG	21Ah	—	29Ah	CCP2CON	31Ah	—	39Ah	—
01Bh	T2PR	09Bh	ADRESL	11Bh	CM3PSEL	19Bh	SP1BRGL	21Bh	—	29Bh	CCP2CAP	31Bh	MD2CON0	39Bh	MD1CON0
01Ch	T2CON	09Ch	ADRESH	11Ch	CM4CON0	19Ch	SP1BRGH	21Ch	—	29Ch	—	31Ch	MD2CON1	39Ch	MD1CON1
01Dh	T2HLT	09Dh	ADCON0	11Dh	CM4CON1	19Dh	RC1STA	21Dh	BORCON	29Dh	—	31Dh	MD2SRC	39Dh	MD1SRC
01Eh	T2CLKCON	09Eh	ADCON1	11Eh	CM4NSEL	19Eh	TX1STA	21Eh	FVRCON	29Eh	CCPTMRS	31Eh	MD2CARL	39Eh	MD1CARL
01Fh	T2RST	09Fh	ADCON2	11Fh	CM4PSEL	19Fh	BAUD1CON	21Fh	ZCD1CON	29Fh	—	31Fh	MD2CARH	39Fh	MD1CARH
020h	General Purpose Register 80 Bytes	0A0h	General Purpose Register 80 Bytes	120h	General Purpose Register 80 Bytes	1A0h	General Purpose Register 80 Bytes	220h	General Purpose Register 80 Bytes	2A0h	General Purpose Register 80 Bytes	320h	General Purpose Register 80 Bytes	3A0h	General Purpose Register 80 Bytes
06Fh		0EFh		16Fh		1EFh		26Fh		2EFh		36Fh		3EFh	
070h	Common RAM 70h – 7Fh	0F0h	Accesses 70h-7Fh	170h	Accesses 70h-7Fh	1F0h	Accesses 70h-7Fh	270h	Accesses 70h-7Fh	2F0h	Accesses 70h-7Fh	370h	Accesses 70h-7Fh	3F0h	Accesses 70h-7Fh
07Fh		0FFh		17Fh		1FFh		27Fh		2FFh		37Fh		3FFh	

Legend: □ = Unimplemented data memory locations, read as '0'.

Note 1: Unimplemented on PIC16LF1769.



**TABLE 3-7: PIC16(L)F1764 MEMORY MAP (BANKS 8-23)**

BANK 8		BANK 9		BANK 10		BANK 11		BANK 12		BANK 13		BANK 14		BANK 15	
400h	Core Registers (Table 3-2)	480h	Core Registers (Table 3-2)	500h	Core Registers (Table 3-2)	580h	Core Registers (Table 3-2)	600h	Core Registers (Table 3-2)	680h	Core Registers (Table 3-2)	700h	Core Registers (Table 3-2)	780h	Core Registers (Table 3-2)
40Bh	—	48Bh	—	50Bh	—	58Bh	—	60Bh	—	68Bh	—	70Bh	—	78Bh	—
40Ch	—	48Ch	—	50Ch	—	58Ch	—	60Ch	—	68Ch	—	70Ch	—	78Ch	—
40Dh	—	48Dh	—	50Dh	—	58Dh	—	60Dh	—	68Dh	COG1PHR	70Dh	COG2PHR	78Dh	—
40Eh	HIDRVC	48Eh	—	50Eh	—	58Eh	—	60Eh	—	68Eh	COG1PHF	70Eh	COG2PHF	78Eh	—
40Fh	—	48Fh	—	50Fh	OPA1NCHS	58Fh	—	60Fh	—	68Fh	COG1BLKR	70Fh	COG2BLKR	78Fh	—
410h	—	490h	—	510h	OPA1PCHS	590h	DACL	610h	—	690h	COG1BLKF	710h	COG2BLKF	790h	—
411h	—	491h	—	511h	OPA1CON	591h	DAC1CON0	611h	—	691h	COG1DBR	711h	COG2DBR	791h	—
412h	—	492h	—	512h	OPA1ORS	592h	DAC1REFL	612h	—	692h	COG1DBF	712h	COG2DBF	792h	—
413h	T4TMR	493h	TMR3L	513h	—	593h	DAC1REFH	613h	—	693h	COG1CON0	713h	COG2CON0	793h	—
414h	T4PR	494h	TMR3H	514h	—	594h	—	614h	—	694h	COG1CON1	714h	COG2CON1	794h	PRG1RTSS
415h	T4CON	495h	T3CON	515h	—	595h	—	615h	—	695h	COG1RIS0	715h	COG2RIS0	795h	PRG1FTSS
416h	T4HLT	496h	T3GCON	516h	—	596h	—	616h	—	696h	COG1RIS1	716h	COG2RIS1	796h	PRG1INS
417h	T4CLKCON	497h	—	517h	—	597h	DAC3CON0	617h	PWM3DCL	697h	COG1RSIM0	717h	COG2RSIM0	797h	PRG1CON0
418h	T4RST	498h	—	518h	—	598h	DAC3REF	618h	PWM3DCH	698h	COG1RSIM1	718h	COG2RSIM1	798h	PRG1CON1
419h	—	499h	—	519h	—	599h	—	619h	PWM3CON	699h	COG1FIS0	719h	COG2FIS0	799h	PRG1CON2
41Ah	T6TMR	49Ah	TMR5L	51Ah	—	59Ah	—	61Ah	—	69Ah	COG1FIS1	71Ah	COG2FIS1	79Ah	—
41Bh	T6PR	49Bh	TMR5H	51Bh	—	59Bh	—	61Bh	—	69Bh	COG1FSIM0	71Bh	COG2FSIM0	79Bh	—
41Ch	T6CON	49Ch	T5CON	51Ch	—	59Ch	—	61Ch	—	69Ch	COG1FSIM1	71Ch	COG2FSIM1	79Ch	—
41Dh	T6HLT	49Dh	T5GCON	51Dh	—	59Dh	—	61Dh	—	69Dh	COG1ASD0	71Dh	COG2ASD0	79Dh	—
41Eh	T6CLKCON	49Eh	—	51Eh	—	59Eh	—	61Eh	—	69Eh	COG1ASD1	71Eh	COG2ASD1	79Eh	—
41Fh	T6RST	49Fh	—	51Fh	—	59Fh	—	61Fh	—	69Fh	COG1STR	71Fh	COG2STR	79Fh	—
420h	Unimplemented Read as '0'	4A0h	Unimplemented Read as '0'	520h	Unimplemented Read as '0'	5A0h	Unimplemented Read as '0'	620h	Unimplemented Read as '0'	6A0h	Unimplemented Read as '0'	720h	Unimplemented Read as '0'	7A0h	Unimplemented Read as '0'
46Fh	Accesses 70h-7Fh	4EFh	Accesses 70h-7Fh	56Fh	Accesses 70h-7Fh	5EFh	Accesses 70h-7Fh	66Fh	Accesses 70h-7Fh	6EFh	Accesses 70h-7Fh	76Fh	Accesses 70h-7Fh	7EFh	Accesses 70h-7Fh
470h	—	4F0h	—	570h	—	5F0h	—	670h	—	6F0h	—	770h	—	7F0h	—
47Fh	—	4FFh	—	57Fh	—	5FFh	—	67Fh	—	6FFh	—	77Fh	—	7FFh	—
BANK 16		BANK 17		BANK 18		BANK 19		BANK 20		BANK 21		BANK 22		BANK 23	
800h	Core Registers (Table 3-2)	880h	Core Registers (Table 3-2)	900h	Core Registers (Table 3-2)	980h	Core Registers (Table 3-2)	A00h	Core Registers (Table 3-2)	A80h	Core Registers (Table 3-2)	B00h	Core Registers (Table 3-2)	B80h	Core Registers (Table 3-2)
80Bh	—	88Bh	—	90Bh	—	98Bh	—	A0Bh	—	A8Bh	—	B0Bh	—	B8Bh	—
80Ch	Unimplemented Read as '0'	88Ch	Unimplemented Read as '0'	90Ch	Unimplemented Read as '0'	98Ch	Unimplemented Read as '0'	A0Ch	Unimplemented Read as '0'	A8Ch	Unimplemented Read as '0'	B0Ch	Unimplemented Read as '0'	B8Ch	Unimplemented Read as '0'
86Fh	—	8EFh	—	96Fh	—	9EFh	—	A6Fh	—	A6Fh	—	B6Fh	—	BEFh	—
870h	Accesses 70h-7Fh	8F0h	Accesses 70h-7Fh	970h	Accesses 70h-7Fh	9F0h	Accesses 70h-7Fh	A70h	Accesses 70h-7Fh	A70h	Accesses 70h-7Fh	B70h	Accesses 70h-7Fh	BF0h	Accesses 70h-7Fh
87Fh	—	8FFh	—	97Fh	—	9FFh	—	A7Fh	—	A7Fh	—	B7Fh	—	BFh	—

Legend: □ = Unimplemented data memory locations, read as '0'.

**TABLE 3-8: PIC16(L)F1765 MEMORY MAP (BANKS 8-23)**

BANK 8		BANK 9		BANK 10		BANK 11		BANK 12		BANK 13		BANK 14		BANK 15	
400h	Core Registers (Table 3-2)	480h	Core Registers (Table 3-2)	500h	Core Registers (Table 3-2)	580h	Core Registers (Table 3-2)	600h	Core Registers (Table 3-2)	680h	Core Registers (Table 3-2)	700h	Core Registers (Table 3-2)	780h	Core Registers (Table 3-2)
40Bh	—	48Bh	—	50Bh	—	58Bh	—	60Bh	—	68Bh	—	70Bh	—	78Bh	—
40Ch	—	48Ch	—	50Ch	—	58Ch	—	60Ch	—	68Ch	—	70Ch	—	78Ch	—
40Dh	—	48Dh	—	50Dh	—	58Dh	—	60Dh	—	68Dh	COG1PHR	70Dh	COG2PHR	78Dh	—
40Eh	HIDRVC	48Eh	—	50Eh	—	58Eh	—	60Eh	—	68Eh	COG1PHF	70Eh	COG2PHF	78Eh	—
40Fh	—	48Fh	—	50Fh	OPA1NCHS	58Fh	—	60Fh	—	68Fh	COG1BLKF	70Fh	COG2BLKR	78Fh	—
410h	—	490h	—	510h	OPA1PCHS	590h	DACL	610h	—	690h	COG1BLKF	710h	COG2BLKF	790h	—
411h	—	491h	—	511h	OPA1CON	591h	DAC1CON0	611h	—	691h	COG1DBR	711h	COG2DBR	791h	—
412h	—	492h	—	512h	OPA1ORS	592h	DAC1REFL	612h	—	692h	COG1DBF	712h	COG2DBF	792h	—
413h	T4TMR	493h	TMR3L	513h	—	593h	DAC1REFH	613h	—	693h	COG1CON0	713h	COG2CON0	793h	—
414h	T4PR	494h	TMR3H	514h	—	594h	—	614h	—	694h	COG1CON1	714h	COG2CON1	794h	PRG1RTSS
415h	T4CON	495h	T3CON	515h	—	595h	—	615h	—	695h	COG1RIS0	715h	COG2RIS0	795h	PRG1FTSS
416h	T4HLT	496h	T3GCON	516h	—	596h	—	616h	—	696h	COG1RIS1	716h	COG2RIS1	796h	PRG1INS
417h	T4CLKCON	497h	—	517h	—	597h	DAC3CON0	617h	PWM3DCL	697h	COG1RSIM0	717h	COG2RSIM0	797h	PRG1CON0
418h	T4RST	498h	—	518h	—	598h	DAC3REF	618h	PWM3DCH	698h	COG1RSIM1	718h	COG2RSIM1	798h	PRG1CON1
419h	—	499h	—	519h	—	599h	—	619h	PWM3CON	699h	COG1FIS0	719h	COG2FIS0	799h	PRG1CON2
41Ah	T6TMR	49Ah	TMR5L	51Ah	—	59Ah	—	61Ah	—	69Ah	COG1FIS1	71Ah	COG2FIS1	79Ah	—
41Bh	T6PR	49Bh	TMR5H	51Bh	—	59Bh	—	61Bh	—	69Bh	COG1FSIM0	71Bh	COG2FSIM0	79Bh	—
41Ch	T6CON	49Ch	T5CON	51Ch	—	59Ch	—	61Ch	—	69Ch	COG1FSIM1	71Ch	COG2FSIM1	79Ch	—
41Dh	T6HLT	49Dh	T5GCON	51Dh	—	59Dh	—	61Dh	—	69Dh	COG1ASD0	71Dh	COG2ASD0	79Dh	—
41Eh	T6CLKCON	49Eh	—	51Eh	—	59Eh	—	61Eh	—	69Eh	COG1ASD1	71Eh	COG2ASD1	79Eh	—
41Fh	T6RST	49Fh	—	51Fh	—	59Fh	—	61Fh	—	69Fh	COG1STR	71Fh	COG2STR	79Fh	—
420h	General Purpose Register 80 Bytes	4A0h	General Purpose Register 80 Bytes	520h	General Purpose Register 80 Bytes	5A0h	General Purpose Register 80 Bytes	620h	General Purpose Register 48 Bytes	6A0h	Unimplemented Read as '0'	720h	Unimplemented Read as '0'	7A0h	Unimplemented Read as '0'
46Fh	—	4EFh	—	56Fh	—	5EFh	—	64Fh	Unimplemented Read as '0'	6EFh	—	76Fh	—	7EFh	—
470h	Accesses 70h-7Fh	4F0h	Accesses 70h-7Fh	570h	Accesses 70h-7Fh	5F0h	Accesses 70h-7Fh	650h	Accesses 70h-7Fh	6F0h	Accesses 70h-7Fh	770h	Accesses 70h-7Fh	7F0h	Accesses 70h-7Fh
47Fh	—	4FFh	—	57Fh	—	5FFh	—	67Fh	—	6FFh	—	77Fh	—	7FFh	—
BANK 16		BANK 17		BANK 18		BANK 19		BANK 20		BANK 21		BANK 22		BANK 23	
800h	Core Registers (Table 3-2)	880h	Core Registers (Table 3-2)	900h	Core Registers (Table 3-2)	980h	Core Registers (Table 3-2)	A00h	Core Registers (Table 3-2)	A80h	Core Registers (Table 3-2)	B00h	Core Registers (Table 3-2)	B80h	Core Registers (Table 3-2)
80Bh	—	88Bh	—	90Bh	—	98Bh	—	A0Bh	—	A8Bh	—	B0Bh	—	B8Bh	—
80Ch	Unimplemented Read as '0'	88Ch	Unimplemented Read as '0'	90Ch	Unimplemented Read as '0'	98Ch	Unimplemented Read as '0'	A0Ch	Unimplemented Read as '0'	A8Ch	Unimplemented Read as '0'	B0Ch	Unimplemented Read as '0'	B8Ch	Unimplemented Read as '0'
86Fh	—	8EFh	—	96Fh	—	9EFh	—	A6Fh	—	A6Fh	—	B6Fh	—	BEFh	—
870h	Accesses 70h-7Fh	8F0h	Accesses 70h-7Fh	970h	Accesses 70h-7Fh	9F0h	Accesses 70h-7Fh	A70h	Accesses 70h-7Fh	AF0h	Accesses 70h-7Fh	B70h	Accesses 70h-7Fh	BF0h	Accesses 70h-7Fh
87Fh	—	8FFh	—	97Fh	—	9FFh	—	A7Fh	—	AFFh	—	B7Fh	—	BFh	—

Legend: □ = Unimplemented data memory locations, read as '0'.

TABLE 3-9: PIC16(L)F1768 MEMORY MAP (BANKS 8-23)

BANK 8		BANK 9		BANK 10		BANK 11		BANK 12		BANK 13		BANK 14		BANK 15	
400h	Core Registers (Table 3-2)	480h	Core Registers (Table 3-2)	500h	Core Registers (Table 3-2)	580h	Core Registers (Table 3-2)	600h	Core Registers (Table 3-2)	680h	Core Registers (Table 3-2)	700h	Core Registers (Table 3-2)	780h	Core Registers (Table 3-2)
40Bh	—	48Bh	—	50Bh	—	58Bh	—	60Bh	—	68Bh	—	70Bh	—	78Bh	—
40Ch	—	48Ch	—	50Ch	—	58Ch	—	60Ch	—	68Ch	—	70Ch	—	78Ch	—
40Dh	—	48Dh	—	50Dh	—	58Dh	—	60Dh	—	68Dh	COG1PHR	70Dh	COG2PHR	78Dh	—
40Eh	HIDRVC	48Eh	—	50Eh	—	58Eh	—	60Eh	—	68Eh	COG1PHF	70Eh	COG2PHF	78Eh	—
40Fh	—	48Fh	—	50Fh	OPA1NCHS	58Fh	—	60Fh	—	68Fh	COG1BLKR	70Fh	COG2BLKR	78Fh	—
410h	—	490h	—	510h	OPA1PCHS	590h	DACL	610h	—	690h	COG1BLKF	710h	COG2BLKF	790h	—
411h	—	491h	—	511h	OPA1CON	591h	DAC1CON0	611h	—	691h	COG1DBR	711h	COG2DBR	791h	—
412h	—	492h	—	512h	OPA1ORS	592h	DAC1REFL	612h	—	692h	COG1DBF	712h	COG2DBF	792h	—
413h	T4TMR	493h	TMR3L	513h	OPA2NCHS	593h	DAC1REFH	613h	—	693h	COG1CON0	713h	COG2CON0	793h	—
414h	T4PR	494h	TMR3H	514h	OPA2PCHS	594h	DAC2CON0	614h	—	694h	COG1CON1	714h	COG2CON1	794h	PRG1RTSS
415h	T4CON	495h	T3CON	515h	OPA2CON	595h	DAC2REFL	615h	—	695h	COG1RIS0	715h	COG2RIS0	795h	PRG1FTSS
416h	T4HLT	496h	T3GCON	516h	OPA2ORS	596h	DAC2REFH	616h	—	696h	COG1RIS1	716h	COG2RIS1	796h	PRG1INS
417h	T4CLKCON	497h	—	517h	—	597h	DAC3CON0	617h	PWM3DCL	697h	COG1RSIM0	717h	COG2RSIM0	797h	PRG1CON0
418h	T4RST	498h	—	518h	—	598h	DAC3REF	618h	PWM3DCH	698h	COG1RSIM1	718h	COG2RSIM1	798h	PRG1CON1
419h	—	499h	—	519h	—	599h	DAC4CON0	619h	PWM3CON	699h	COG1FIS0	719h	COG2FIS0	799h	PRG1CON2
41Ah	T6TMR	49Ah	TMR5L	51Ah	—	59Ah	DAC4REF	61Ah	PWM4DCL	69Ah	COG1FIS1	71Ah	COG2FIS1	79Ah	PRG2RTSS
41Bh	T6PR	49Bh	TMR5H	51Bh	—	59Bh	—	61Bh	PWM4DCH	69Bh	COG1FSIM0	71Bh	COG2FSIM0	79Bh	PRG2FTSS
41Ch	T6CON	49Ch	T5CON	51Ch	—	59Ch	—	61Ch	PWM4CON	69Ch	COG1FSIM1	71Ch	COG2FSIM1	79Ch	PRG2INS
41Dh	T6HLT	49Dh	T5GCON	51Dh	—	59Dh	—	61Dh	—	69Dh	COG1ASD0	71Dh	COG2ASD0	79Dh	PRG2CON0
41Eh	T6CLKCON	49Eh	—	51Eh	—	59Eh	—	61Eh	—	69Eh	COG1ASD1	71Eh	COG2ASD1	79Eh	PRG2CON1
41Fh	T6RST	49Fh	—	51Fh	—	59Fh	—	61Fh	—	69Fh	COG1STR	71Fh	COG2STR	79Fh	PRG2CON2
420h	Unimplemented Read as '0'	4A0h	Unimplemented Read as '0'	520h	Unimplemented Read as '0'	5A0h	Unimplemented Read as '0'	620h	Unimplemented Read as '0'	6A0h	Unimplemented Read as '0'	720h	Unimplemented Read as '0'	7A0h	Unimplemented Read as '0'
46Fh	—	4EFh	—	56Fh	—	5EFh	—	66Fh	—	6EFh	—	76Fh	—	7EFh	—
470h	Accesses 70h-7Fh	4F0h	Accesses 70h-7Fh	570h	Accesses 70h-7Fh	5F0h	Accesses 70h-7Fh	670h	Accesses 70h-7Fh	6F0h	Accesses 70h-7Fh	770h	Accesses 70h-7Fh	7F0h	Accesses 70h-7Fh
47Fh	—	4FFh	—	57Fh	—	5FFh	—	67Fh	—	6FFh	—	77Fh	—	7FFh	—
BANK 16		BANK 17		BANK 18		BANK 19		BANK 20		BANK 21		BANK 22		BANK 23	
800h	Core Registers (Table 3-2)	880h	Core Registers (Table 3-2)	900h	Core Registers (Table 3-2)	980h	Core Registers (Table 3-2)	A00h	Core Registers (Table 3-2)	A80h	Core Registers (Table 3-2)	B00h	Core Registers (Table 3-2)	B80h	Core Registers (Table 3-2)
80Bh	—	88Bh	—	90Bh	—	98Bh	—	A0Bh	—	A8Bh	—	B0Bh	—	B8Bh	—
80Ch	Unimplemented Read as '0'	88Ch	Unimplemented Read as '0'	90Ch	Unimplemented Read as '0'	98Ch	Unimplemented Read as '0'	A0Ch	Unimplemented Read as '0'	A8Ch	Unimplemented Read as '0'	B0Ch	Unimplemented Read as '0'	B8Ch	Unimplemented Read as '0'
86Fh	—	8EFh	—	96Fh	—	9EFh	—	A6Fh	—	AEFh	—	B6Fh	—	BEFh	—
870h	Accesses 70h-7Fh	8F0h	Accesses 70h-7Fh	970h	Accesses 70h-7Fh	9F0h	Accesses 70h-7Fh	A70h	Accesses 70h-7Fh	AF0h	Accesses 70h-7Fh	B70h	Accesses 70h-7Fh	BF0h	Accesses 70h-7Fh
87Fh	—	8FFh	—	97Fh	—	9FFh	—	A7Fh	—	AFFh	—	B7Fh	—	BFh	—

Legend: □ = Unimplemented data memory locations, read as '0'.

**TABLE 3-10: PIC16(L)F1769 MEMORY MAP (BANKS 8-23)**

BANK 8		BANK 9		BANK 10		BANK 11		BANK 12		BANK 13		BANK 14		BANK 15	
400h	Core Registers (Table 3-2)	480h	Core Registers (Table 3-2)	500h	Core Registers (Table 3-2)	580h	Core Registers (Table 3-2)	600h	Core Registers (Table 3-2)	680h	Core Registers (Table 3-2)	700h	Core Registers (Table 3-2)	780h	Core Registers (Table 3-2)
40Bh	—	48Bh	—	50Bh	—	58Bh	—	60Bh	—	68Bh	—	70Bh	—	78Bh	—
40Ch	—	48Ch	—	50Ch	—	58Ch	—	60Ch	—	68Ch	—	70Ch	—	78Ch	—
40Dh	—	48Dh	—	50Dh	—	58Dh	—	60Dh	—	68Dh	COG1PHR	70Dh	COG2PHR	78Dh	—
40Eh	HIDRVC	48Eh	—	50Eh	—	58Eh	—	60Eh	—	68Eh	COG1PHF	70Eh	COG2PHF	78Eh	—
40Fh	—	48Fh	—	50Fh	OPA1NCHS	58Fh	—	60Fh	—	68Fh	COG1BLKR	70Fh	COG2BLKR	78Fh	—
410h	—	490h	—	510h	OPA1PCHS	590h	DACL	610h	—	690h	COG1BLKF	710h	COG2BLKF	790h	—
411h	—	491h	—	511h	OPA1CON	591h	DAC1CON0	611h	—	691h	COG1DBR	711h	COG2DBR	791h	—
412h	—	492h	—	512h	OPA1ORS	592h	DAC1REFL	612h	—	692h	COG1DBF	712h	COG2DBF	792h	—
413h	T4TMR	493h	TMR3L	513h	OPA2NCHS	593h	DAC1REFH	613h	—	693h	COG1CON0	713h	COG2CON0	793h	—
414h	T4PR	494h	TMR3H	514h	OPA2PCHS	594h	DAC2CON0	614h	—	694h	COG1CON1	714h	COG2CON1	794h	PRG1RTSS
415h	T4CON	495h	T3CON	515h	OPA2CON	595h	DAC2REFL	615h	—	695h	COG1RIS0	715h	COG2RIS0	795h	PRG1FTSS
416h	T4HLT	496h	T3GCON	516h	OPA2ORS	596h	DAC2REFH	616h	—	696h	COG1RIS1	716h	COG2RIS1	796h	PRG1INS
417h	T4CLKCON	497h	—	517h	—	597h	DAC3CON0	617h	PWM3DCL	697h	COG1RSIM0	717h	COG2RSIM0	797h	PRG1CON0
418h	T4RST	498h	—	518h	—	598h	DAC3REF	618h	PWM3DCH	698h	COG1RSIM1	718h	COG2RSIM1	798h	PRG1CON1
419h	—	499h	—	519h	—	599h	DAC4CON0	619h	PWM3CON	699h	COG1FIS0	719h	COG2FIS0	799h	PRG1CON2
41Ah	T6TMR	49Ah	TMR5L	51Ah	—	59Ah	DAC4REF	61Ah	PWM4DCL	69Ah	COG1FIS1	71Ah	COG2FIS1	79Ah	PRG2RTSS
41Bh	T6PR	49Bh	TMR5H	51Bh	—	59Bh	—	61Bh	PWM4DCH	69Bh	COG1FSIM0	71Bh	COG2FSIM0	79Bh	PRG2FTSS
41Ch	T6CON	49Ch	T5CON	51Ch	—	59Ch	—	61Ch	PWM4CON	69Ch	COG1FSIM1	71Ch	COG2FSIM1	79Ch	PRG2INS
41Dh	T6HLT	49Dh	T5GCON	51Dh	—	59Dh	—	61Dh	—	69Dh	COG1ASD0	71Dh	COG2ASD0	79Dh	PRG2CON0
41Eh	T6CLKCON	49Eh	—	51Eh	—	59Eh	—	61Eh	—	69Eh	COG1ASD1	71Eh	COG2ASD1	79Eh	PRG2CON1
41Fh	T6RST	49Fh	—	51Fh	—	59Fh	—	61Fh	—	69Fh	COG1STR	71Fh	COG2STR	79Fh	PRG2CON2
420h	General Purpose Register 80 Bytes	4A0h	General Purpose Register 80 Bytes	520h	General Purpose Register 80 Bytes	5A0h	General Purpose Register 80 Bytes	620h	General Purpose Register 48 Bytes	6A0h	Unimplemented Read as '0'	720h	Unimplemented Read as '0'	7A0h	Unimplemented Read as '0'
46Fh	—	4EFh	—	56Fh	—	5EFh	—	66Fh	Unimplemented Read as '0'	6EFh	—	76Fh	—	7EFh	—
470h	Accesses 70h-7Fh	4F0h	Accesses 70h-7Fh	570h	Accesses 70h-7Fh	5F0h	Accesses 70h-7Fh	670h	Accesses 70h-7Fh	6F0h	Accesses 70h-7Fh	770h	Accesses 70h-7Fh	7F0h	Accesses 70h-7Fh
47Fh	—	4FFh	—	57Fh	—	5FFh	—	67Fh	—	6FFh	—	77Fh	—	7FFh	—
BANK 16		BANK 17		BANK 18		BANK 19		BANK 20		BANK 21		BANK 22		BANK 23	
800h	Core Registers (Table 3-2)	880h	Core Registers (Table 3-2)	900h	Core Registers (Table 3-2)	980h	Core Registers (Table 3-2)	A00h	Core Registers (Table 3-2)	A80h	Core Registers (Table 3-2)	B00h	Core Registers (Table 3-2)	B80h	Core Registers (Table 3-2)
80Bh	—	88Bh	—	90Bh	—	98Bh	—	A0Bh	—	A8Bh	—	B0Bh	—	B8Bh	—
80Ch	Unimplemented Read as '0'	88Ch	Unimplemented Read as '0'	90Ch	Unimplemented Read as '0'	98Ch	Unimplemented Read as '0'	A0Ch	Unimplemented Read as '0'	A8Ch	Unimplemented Read as '0'	B0Ch	Unimplemented Read as '0'	B8Ch	Unimplemented Read as '0'
86Fh	—	8EFh	—	96Fh	—	9EFh	—	A6Fh	—	A6Fh	—	B6Fh	—	BEFh	—
870h	Accesses 70h-7Fh	8F0h	Accesses 70h-7Fh	970h	Accesses 70h-7Fh	9F0h	Accesses 70h-7Fh	A70h	Accesses 70h-7Fh	AF0h	Accesses 70h-7Fh	B70h	Accesses 70h-7Fh	BF0h	Accesses 70h-7Fh
87Fh	—	8FFh	—	97Fh	—	9FFh	—	A7Fh	—	AFFh	—	B7Fh	—	BFFh	—

Legend: □ = Unimplemented data memory locations, read as '0'.

**TABLE 3-11: PIC16(L)F1764/5/8/9 MEMORY MAP (BANKS 24-31)**

BANK 24		BANK 25		BANK 26		BANK 27		BANK 28		BANK 29		BANK 30		BANK 31				
C00h	Core Registers (Table 3-2)	C80h	Core Registers (Table 3-2)	D00h	Core Registers (Table 3-2)	D80h	Core Registers (Table 3-2)	E00h	Core Registers (Table 3-2)	E80h	Core Registers (Table 3-2)	F00h	Core Registers (Table 3-2)	F80h	Core Registers (Table 3-2)			
C0Bh	—	C8Bh	—	D0Bh	—	D8Bh	—	E0Bh	—	E8Bh	—	F0Bh	—	F8Bh	—			
C0Ch	—	C8Ch	—	D0Ch	—													
C0Dh	—	C8Dh	—	D0Dh	—													
C0Eh	—	C8Eh	—	D0Eh	—													
C0Fh	—	C8Fh	—	D0Fh	—													
C10h	—	C90h	—	D10h	—													
C11h	—	C91h	—	D11h	—													
C12h	—	C92h	—	D12h	—													
C13h	—	C93h	—	D13h	—													
C14h	—	C94h	—	D14h	—													
C15h	—	C95h	—	D15h	—													
C16h	—	C96h	—	D16h	—													
C17h	—	C97h	—	D17h	—													
C18h	—	C98h	—	D18h	—													
C19h	—	C99h	—	D19h	—													
C1Ah	—	C9Ah	—	D1Ah	—													
C1Bh	—	C9Bh	—	D1Bh	—													
C1Ch	—	C9Ch	—	D1Ch	—													
C1Dh	—	C9Dh	—	D1Dh	—													
C1Eh	—	C9Eh	—	D1Eh	—													
C1Fh	—	C9Fh	—	D1Fh	—													
C20h	Unimplemented Read as '0'	CA0h	Unimplemented Read as '0'	D20h	Unimplemented Read as '0'													
C6Fh		CEFh		D6Fh		DEFh	E6Fh	EEFh	F6Fh	FEFh								
C70h		Accesses 70h-7Fh		CF0h		Accesses 70h-7Fh	D70h	Accesses 70h-7Fh	DF0h	Accesses 70h-7Fh	E70h	Accesses 70h-7Fh	EF0h	Accesses 70h-7Fh	F70h	Accesses 70h-7Fh	FF0h	Accesses 70h-7Fh
CFFh		Accesses 70h-7Fh		CFh		Accesses 70h-7Fh	D7Fh	Accesses 70h-7Fh	DFh	Accesses 70h-7Fh	E7Fh	Accesses 70h-7Fh	EFh	Accesses 70h-7Fh	F7Fh	Accesses 70h-7Fh	FFh	Accesses 70h-7Fh

Legend: □ = Unimplemented data memory locations, read as '0'.

**TABLE 3-12: PIC16(L)F1764/5 MEMORY MAP (BANKS 27-30)**

Bank 27		Bank 28		Bank 29		Bank 30	
D8Ch	—	E0Ch	—	E8Ch	—	F0Ch	—
D8Dh	—	E0Dh	—	E8Dh	—	F0Dh	—
D8Eh	PWMEN	E0Eh	—	E8Eh	—	F0Eh	—
D8Fh	PWMLD	E0Fh	PPSLOCK	E8Fh	—	F0Fh	CLCDATA
D90h	PWMOUT	E10h	INTPPS	E90h	RA0PPS	F10h	CLC1CON
D91h	PWM5PHL	E11h	T0CKIPPS	E91h	RA1PPS	F11h	CLC1POL
D92h	PWM5PHH	E12h	T1CKIPPS	E92h	RA2PPS	F12h	CLC1SEL0
D93h	PWM5DCL	E13h	T1GPPS	E93h	—	F13h	CLC1SEL1
D94h	PWM5DCH	E14h	CCP1PPS	E94h	RA4PPS	F14h	CLC1SEL2
D95h	PWM5PRL	E15h	—	E95h	RA5PPS	F15h	CLC1SEL3
D96h	PWM5PRH	E16h	COG1INPPS	E96h	—	F16h	CLC1GLS0
D97h	PWM5OFL	E17h	—	E97h	—	F17h	CLC1GLS1
D98h	PWM5OFH	E18h	—	E98h	—	F18h	CLC1GLS2
D99h	PWM5TMRL	E19h	T2INPPS	E99h	—	F19h	CLC1GLS3
D9Ah	PWM5TMRH	E1Ah	T3CKIPPS	E9Ah	—	F1Ah	CLC2CON
D9Bh	PWM5CON	E1Bh	T3GPPS	E9Bh	—	F1Bh	CLC2POL
D9Ch	PWM5INTE	E1Ch	T4INPPS	E9Ch	—	F1Ch	CLC2SEL0
D9Dh	PWM5INTF	E1Dh	T5CKIPPS	E9Dh	—	F1Dh	CLC2SEL1
D9Eh	PWM5CLKCON	E1Eh	T5GPPS	E9Eh	—	F1Eh	CLC2SEL2
D9Fh	PWM5LDCON	E1Fh	T6INPPS	E9Fh	—	F1Fh	CLC2SEL3
DA0h	PWM5OFCON	E20h	SSPCLKPPS	EA0h	RC0PPS	F20h	CLC2GLS0
DA1h	—	E21h	SSPDATPPS	EA1h	RC1PPS	F21h	CLC2GLS1
DA2h	—	E22h	SSPSSPPS	EA2h	RC2PPS	F22h	CLC2GLS2
DA3h	—	E23h	—	EA3h	RC3PPS	F23h	CLC2GLS3
DA4h	—	E24h	RXPPS	EA4h	RC4PPS	F24h	CLC3CON
DA5h	—	E25h	CKPPS	EA5h	RC5PPS	F25h	CLC3POL
DA6h	—	E26h	—	EA6h	—	F26h	CLC3SEL0
DA7h	—	E27h	—	EA7h	—	F27h	CLC3SEL1
DA8h	—	E28h	CLCIN0PPS	EA8h	—	F28h	CLC3SEL2
DA9h	—	E29h	CLCIN1PPS	EA9h	—	F29h	CLC3SEL3
DAAh	—	E2Ah	CLCIN2PPS	EAAh	—	F2Ah	CLC3GLS0
DABh	—	E2Bh	CLCIN3PPS	EABh	—	F2Bh	CLC3GLS1
DACH	—	E2Ch	PRG1FPPS	EACH	—	F2Ch	CLC3GLS2
DADh	—	E2Dh	PRG1RPPS	EADh	—	F2Dh	CLC3GLS3
DAEh	—	E2Eh	—	EAEh	—	F2Eh	—
DAFh	—	E2Fh	—	EAFh	—	F2Fh	—
DB0h	—	E30h	MD1CHPPS	EB0h	—	F30h	—
DB1h	—	E31h	MD1CLPPS	EB1h	—	F31h	—
DB2h	—	E32h	MD1MODPPS	EB2h	—	F32h	—
DB3h	—	E33h	—	EB3h	—	F33h	—
DB4h	—	E34h	—	EB4h	—	F34h	—
DB5h	—	E35h	—	EB5h	—	F35h	—
DB6h	—	E36h	—	EB6h	—	F36h	—
DB7h	—	E37h	—	EB7h	—	F37h	—
DB8h	—	E38h	—	EB8h	—	F38h	—
DB9h	—	E39h	—	EB9h	—	F39h	—
DBAh	—	E3Ah	—	EBAh	—	F3Ah	—
DBBh	—	E3Bh	—	EBBh	—	F3Bh	—
DBCh	—	E3Ch	—	EBCh	—	F3Ch	—
DBDh	—	E3Dh	—	EBDh	—	F3Dh	—
DBEh	—	E3Eh	—	EBEh	—	F3Eh	—
DBFh	—	E3Fh	—	EBFh	—	F3Fh	—
DC0h	—	E40h	—	EC0h	—	F40h	—
DEFh	—	E6Fh	—	EEFh	—	F6Fh	—

**Legend:** □ = Unimplemented data memory locations, read as '0'.

**TABLE 3-13: PIC16(L)F1768/9 MEMORY MAP (BANKS 27-30)**

Bank 27		Bank 28		Bank 29		Bank 30	
D8Ch	—	E0Ch	—	E8Ch	—	F0Ch	—
D8Dh	—	E0Dh	—	E8Dh	—	F0Dh	—
D8Eh	PWMEN	E0Eh	—	E8Eh	—	F0Eh	—
D8Fh	PWMLD	E0Fh	PPSLOCK	E8Fh	—	F0Fh	CLCDATA
D90h	PWMOUT	E10h	INTPPS	E90h	RA0PPS	F10h	CLC1CON
D91h	PWM5PHL	E11h	T0CKIPPS	E91h	RA1PPS	F11h	CLC1POL
D92h	PWM5PHH	E12h	T1CKIPPS	E92h	RA2PPS	F12h	CLC1SEL0
D93h	PWM5DCL	E13h	T1GPPS	E93h	—	F13h	CLC1SEL1
D94h	PWM5DCH	E14h	CCP1PPS	E94h	RA4PPS	F14h	CLC1SEL2
D95h	PWM5PRL	E15h	CCP2PPS	E95h	RA5PPS	F15h	CLC1SEL3
D96h	PWM5PRH	E16h	COG1INPPS	E96h	—	F16h	CLC1GLS0
D97h	PWM5OFL	E17h	COG2INPPS	E97h	—	F17h	CLC1GLS1
D98h	PWM5OFH	E18h	—	E98h	—	F18h	CLC1GLS2
D99h	PWM5TMRL	E19h	T2INPPS	E99h	—	F19h	CLC1GLS3
D9Ah	PWM5TMRH	E1Ah	T3CKIPPS	E9Ah	—	F1Ah	CLC2CON
D9Bh	PWM5CON	E1Bh	T3GPPS	E9Bh	—	F1Bh	CLC2POL
D9Ch	PWM5INTE	E1Ch	T4INPPS	E9Ch	RB4PPS	F1Ch	CLC2SEL0
D9Dh	PWM5INTF	E1Dh	T5CKIPPS	E9Dh	RB5PPS	F1Dh	CLC2SEL1
D9Eh	PWM5CLKCON	E1Eh	T5GPPS	E9Eh	RB6PPS	F1Eh	CLC2SEL2
D9Fh	PWM5LDCON	E1Fh	T6INPPS	E9Fh	RB7PPS	F1Fh	CLC2SEL3
DA0h	PWM5OFCON	E20h	SSPCLKPPS	EA0h	RC0PPS	F20h	CLC2GLS0
DA1h	PWM6PHL	E21h	SSPDATPPS	EA1h	RC1PPS	F21h	CLC2GLS1
DA2h	PWM6PHH	E22h	SSPSSPPS	EA2h	RC2PPS	F22h	CLC2GLS2
DA3h	PWM6DCL	E23h	—	EA3h	RC3PPS	F23h	CLC2GLS3
DA4h	PWM6DCH	E24h	RXPPS	EA4h	RC4PPS	F24h	CLC3CON
DA5h	PWM6PRL	E25h	CKPPS	EA5h	RC5PPS	F25h	CLC3POL
DA6h	PWM6PRH	E26h	—	EA6h	RC6PPS	F26h	CLC3SEL0
DA7h	PWM6OFL	E27h	—	EA7h	RC7PPS	F27h	CLC3SEL1
DA8h	PWM6OFH	E28h	CLCIN0PPS	EA8h	—	F28h	CLC3SEL2
DA9h	PWM6TMRL	E29h	CLCIN1PPS	EA9h	—	F29h	CLC3SEL3
DAAh	PWM6TMRH	E2Ah	CLCIN2PPS	EAAh	—	F2Ah	CLC3GLS0
DABh	PWM6CON	E2Bh	CLCIN3PPS	EABh	—	F2Bh	CLC3GLS1
DACh	PWM6INTE	E2Ch	PRG1FPPS	EACH	—	F2Ch	CLC3GLS2
DADh	PWM6INTF	E2Dh	PRG1RPPS	EADh	—	F2Dh	CLC3GLS3
DAEh	PWM6CLKCON	E2Eh	PRG2FPPS	EAEh	—	F2Eh	—
DAFh	PWM6LDCON	E2Fh	PRG2RPPS	EAfh	—	F2Fh	—
DB0h	PWM6OFCON	E30h	MD1CHPPS	EB0h	—	F30h	—
DB1h	—	E31h	MD1CLPPS	EB1h	—	F31h	—
DB2h	—	E32h	MD1MODPPS	EB2h	—	F32h	—
DB3h	—	E33h	MD2CHPPS	EB3h	—	F33h	—
DB4h	—	E34h	MD2CLPPS	EB4h	—	F34h	—
DB5h	—	E35h	MD2MODPPS	EB5h	—	F35h	—
DB6h	—	E36h	—	EB6h	—	F36h	—
DB7h	—	E37h	—	EB7h	—	F37h	—
DB8h	—	E38h	—	EB8h	—	F38h	—
DB9h	—	E39h	—	EB9h	—	F39h	—
DBAh	—	E3Ah	—	EBAh	—	F3Ah	—
DBBh	—	E3Bh	—	EBBh	—	F3Bh	—
DBCh	—	E3Ch	—	EBCh	—	F3Ch	—
DBDh	—	E3Dh	—	EBDh	—	F3Dh	—
DBEh	—	E3Eh	—	EBEh	—	F3Eh	—
DBFh	—	E3Fh	—	EBFh	—	F3Fh	—
DC0h	—	E40h	—	EC0h	—	F40h	—
DEFh	—	E6Fh	—	EEFh	—	F6Fh	—

**Legend:**  = Unimplemented data memory locations, read as '0',

**TABLE 3-14: PIC16(L)F1764/5/8/9 MEMORY MAP (BANK 31)**

Bank 31	
F8Ch	Unimplemented Read as '0'
FE3h	
FE4h	STATUS_SHAD
FE5h	WREG_SHAD
FE6h	BSR_SHAD
FE7h	PCLATH_SHAD
FE8h	FSR0L_SHAD
FE9h	FSR0H_SHAD
FEAh	FSR1L_SHAD
FEBh	FSR1H_SHAD
FECh	—
FEDh	STKPTR
FEEh	TOSL
FEFh	TOSH

**Legend:**  = Unimplemented data memory locations, read as '0',



# PIC16(L)F1764/5/8/9

## 3.3.6 CORE FUNCTION REGISTERS SUMMARY

The core function registers listed in [Table 3-15](#) can be addressed from any bank.

**TABLE 3-15: CORE FUNCTION REGISTERS SUMMARY<sup>(1)</sup>**

Addr	Name	Bit 7	Bit 6	Bit 5	Bit 4	Bit 3	Bit 2	Bit 1	Bit 0	Value on POR, BOR	Value on All Other Resets	
<b>Bank 0-31</b>												
x00h or x80h	INDF0	Addressing this location uses contents of FSR0H/FSR0L to address data memory (not a physical register)								xxxx xxxx	uuuu uuuu	
x01h or x81h	INDF1	Addressing this location uses contents of FSR1H/FSR1L to address data memory (not a physical register)								xxxx xxxx	uuuu uuuu	
x02h or x82h	PCL	Program Counter (PC) Least Significant Byte								0000 0000	0000 0000	
x03h or x83h	STATUS	—	—	—	$\overline{TO}$	$\overline{PD}$	Z	DC	C	---1 1000	---q quuu	
x04h or x84h	FSR0L	Indirect Data Memory Address 0 Low Pointer								0000 0000	uuuu uuuu	
x05h or x85h	FSR0H	Indirect Data Memory Address 0 High Pointer								0000 0000	0000 0000	
x06h or x86h	FSR1L	Indirect Data Memory Address 1 Low Pointer								0000 0000	uuuu uuuu	
x07h or x87h	FSR1H	Indirect Data Memory Address 1 High Pointer								0000 0000	0000 0000	
x08h or x88h	BSR	—	—	—	BSR4	BSR3	BSR2	BSR1	BSR0	---0 0000	---0 0000	
x09h or x89h	WREG	Working Register								0000 0000	uuuu uuuu	
x0Ah or x8Ah	PCLATH	—	Write Buffer for the upper 7 bits of the Program Counter								-000 0000	-000 0000
x0Bh or x8Bh	INTCON	GIE	PEIE	TMR0IE	INTE	IOCIE	TMR0IF	INTF	IOCIF	0000 0000	0000 0000	

**Legend:** x = unknown; u = unchanged; q = value depends on condition; - = unimplemented, read as '0'.  
Shaded locations are unimplemented, read as '0'.

**Note 1:** These registers can be addressed from any bank.

# PIC16(L)F1764/5/8/9

**TABLE 3-16: SPECIAL FUNCTION REGISTER SUMMARY**

Addr	Name	Bit 7	Bit 6	Bit 5	Bit 4	Bit 3	Bit 2	Bit 1	Bit 0	Value on POR, BOR	Value on All Other Resets		
<b>Bank 0</b>													
00Ch	PORTA	—	—	RA<5:0>				—	—	—	--xx xxxx	--uu uuuu	
00Dh	PORTB <sup>(2)</sup>	RB<7:4>				—	—	—	—	—	xxxx ----	uuuu ----	
00Eh	PORTC	RC<7:6> <sup>(2)</sup>		RC<5:0>				—	—	—	xxxx xxxx	uuuu uuuu	
00Fh	—	Unimplemented										—	—
010h	—	Unimplemented										—	—
011h	PIR1	TMR1GIF	ADIF	RCIF	TXIF	SSP1IF	CCP1IF	TMR2IF	TMR1IF	0000 0000	0000 0000		
012h	PIR2	OSFIF	C2IF	C1IF	—	BCL1IF	C4IF <sup>(2)</sup>	C3IF <sup>(2)</sup>	CCP2IF <sup>(2)</sup>	000- 0000	000- 0000		
013h	PIR3	PWM6IF <sup>(2)</sup>	PWM5IF	COG1IF	ZCDIF	COG2IF <sup>(2)</sup>	CLC3IF	CLC2IF	CLC1IF	0000 0000	0000 0000		
014h	PIR4	—	—	TMR5GIF	TMR5IF	TMR3GIF	TMR3IF	TMR6IF	TRM4IF	--00 0000	--00 0000		
015h	TMR0	Timer0 Module Register									0000 0000	0000 0000	
016h	TMR1L	Holding Register for the Least Significant Byte of the 16-Bit TMR1 Register									xxxx xxxx	uuuu uuuu	
017h	TMR1H	Holding Register for the Most Significant Byte of the 16-Bit TMR1 Register									xxxx xxxx	uuuu uuuu	
018h	T1CON	CS<1:0>		CKPS<1:0>		OSCNEN	SYNCR	—	ON	0000 00-0	uuuu uu-u		
019h	T1GCON	GE	GPOL	GTM	GSPM	GGO/DONER	GVAL	GSS<1:0>		0000 0x00	uuuu uxuu		
01Ah	T2TMR	Holding Register for the 8-Bit TMR2 Register									0000 0000	0000 0000	
01Bh	T2PR	TMR2 Period Register									1111 1111	1111 1111	
01Ch	T2CON	ON	CKPS<2:0>			OUTPS<3:0>			—	—	0000 0000	0000 0000	
01Dh	T2HLT	PSYNC	CKPOL	CKSYNC	MODE<4:0>				—	—	0000 0000	0000 0000	
01Eh	T2CLKCON	—	—	—	—	CS<3:0>			—	—	---- 0000	---- 0000	
01Fh	T2RST	—	—	—	—	RSEL<3:0>			—	—	---- 0000	---- 0000	
<b>Bank 1</b>													
08Ch	TRISA	—	—	TRISA<5:4>		— <sup>(1)</sup>	TRISA<2:0>			--11 1111	--11 1111		
08Dh	TRISB <sup>(2)</sup>	TRISB<7:4>				—	—	—	—	—	1111 ----	1111 ----	
08Eh	TRISC	TRISC<7:6> <sup>(2)</sup>		TRISC<5:0>				—	—	—	1111 1111	1111 1111	
08Fh	—	Unimplemented										—	—
090h	—	Unimplemented										—	—
091h	PIE1	TMR1GIE	ADIE	RCIE	TXIE	SSP1IE	CCP1IE	TMR2IE	TMR1IE	0000 0000	0000 0000		
092h	PIE2	OSFIE	C2IE	C1IE	—	BCL1IE	C4IE <sup>(2)</sup>	C3IE <sup>(2)</sup>	CCP2IE <sup>(2)</sup>	000- 0000	000- 0000		
093h	PIE3	PWM6IE <sup>(2)</sup>	PWM5IE	COG1IE	ZCDIE	COG2IE <sup>(2)</sup>	CLC3IE	CLC2IE	CLC1IE	0000 0000	0000 0000		
094h	PIE4	—	—	TMR5GIE	TMR5IE	TMR3GIE	TMR3IE	TMR6IE	TRM4IE	--00 0000	--00 0000		
095h	OPTION_REG	WPUEN	INTEDG	TMR0CS	TMR0SE	PSA	PS<2:0>			1111 1111	1111 1111		
096h	PCON	STKOVF	STKUNF	—	RWDTR	RMCLR	RI	POR	BOR	00-1 11qq	qq-q qquu		
097h	WDTCON	—	—	WDTPS<4:0>				—	—	—	--01 0110	--01 0110	
098h	OSCTUNE	—	—	TUN<5:0>				—	—	—	--00 0000	--00 0000	
099h	OSCCON	SPLLEN	IRCF<3:0>			—	SCS<1:0>			0011 1-00	0011 1-00		
09Ah	OSCSTAT	SOSCR	PLLRF	OSTS	HFIOFR	HFIOFL	MFIOFR	LFIOFR	HFIOFS	00q0 0q0q	qqqq qq0q		
09Bh	ADRESL	ADC Result Register Low									xxxx xxxx	uuuu uuuu	
09Ch	ADRESH	ADC Result Register High									xxxx xxxx	uuuu uuuu	
09Dh	ADCON0	—	CHS<4:0>				GO/DONER	ADON	—	—	-000 0000	-000 0000	
09Eh	ADCON1	ADFM	ADCS<2:0>			—	ADNREF	ADPREF<1:0>		0000 -000	0000 -000		
09Fh	ADCON2	TRIGSEL<4:0>				—	—	—	—	—	0000 0---	0000 0---	

**Legend:** x = unknown; u = unchanged; q = value depends on condition; - = unimplemented, read as '0'; r = reserved.  
Shaded locations are unimplemented, read as '0'.

- Note**
- 1: Unimplemented, read as '1'.
  - 2: PIC16(L)F1768/9 only.
  - 3: PIC16(L)F1764/5 only.
  - 4: Unimplemented on PIC16LF1764/5/8/9.
  - 5: PIC16(L)F1768/9 only.

# PIC16(L)F1764/5/8/9

**TABLE 3-16: SPECIAL FUNCTION REGISTER SUMMARY (CONTINUED)**

Addr	Name	Bit 7	Bit 6	Bit 5	Bit 4	Bit 3	Bit 2	Bit 1	Bit 0	Value on POR, BOR	Value on All Other Resets	
<b>Bank 2</b>												
10Ch	LATA	—	—	LATA<5:4>			—	LATA<2:0>		--xx -xxx	--uu -uuu	
10Dh	LATB <sup>(2)</sup>	LATB<7:4>					—	—	—	—	xxxx ----	uuuu ----
10Eh	LATC	LATC<7:6> <sup>(2)</sup>			LATC<5:0>					xxxx xxxx	uuuu uuuu	
10Fh	CMOUT	—	—	—	—	MC4OUT <sup>(2)</sup>	MC3OUT <sup>(2)</sup>	MC2OUT	MC1OUT	---- 0000	---- 0000	
110h	CM1CON0	ON	OUT	—	POL	ZLF	Reserved	HYS	SYNC	00-0 0100	00-0 0100	
111h	CM1CON1	—	—	—	—	—	—	INTP	INTN	---- -000	---- -000	
112h	CM1NSEL	—	—	—	—	—	—	NCH<2:0>		---- -000	---- -000	
113h	CM1PSEL	—	—	—	—	—	—	PCH<2:0>		---- -000	---- -000	
114h	CM2CON0	ON	OUT	—	POL	ZLF	Reserved	HYS	SYNC	00-0 0100	00-0 0100	
115h	CM2CON1	—	—	—	—	—	—	INTP	INTN	---- -000	---- -000	
116h	CM2NSEL	—	—	—	—	—	—	NCH<2:0>		---- -000	---- -000	
117h	CM2PSEL	—	—	—	—	—	—	PCH<2:0>		---- -000	---- -000	
118h	CM3CON0 <sup>(2)</sup>	ON	OUT	—	POL	ZLF	Reserved	HYS	SYNC	00-0 0100	00-0 0100	
119h	CM3CON1 <sup>(2)</sup>	—	—	—	—	—	—	INTP	INTN	---- -000	---- -000	
11Ah	CM3NSEL <sup>(2)</sup>	—	—	—	—	—	—	NCH<2:0>		---- -000	---- -000	
11Bh	CM3PSEL <sup>(2)</sup>	—	—	—	—	—	—	PCH<2:0>		---- -000	---- -000	
11Ch	CM4CON0 <sup>(2)</sup>	ON	OUT	—	POL	ZLF	Reserved	HYS	SYNC	00-0 0100	00-0 0100	
11Dh	CM4CON1 <sup>(2)</sup>	—	—	—	—	—	—	INTP	INTN	---- -000	---- -000	
11Eh	CM4NSEL <sup>(2)</sup>	—	—	—	—	—	—	NCH<2:0>		---- -000	---- -000	
11Fh	CM4PSEL <sup>(2)</sup>	—	—	—	—	—	—	PCH<2:0>		---- -000	---- -000	
<b>Bank 3</b>												
18Ch	ANSELA	—	—	—	ANSA4	—	ANSA<2:0>			---1 -111	---1 -111	
18Dh	ANSELB <sup>(2)</sup>	ANSB<7:4>					—	—	—	—	1111 ----	1111 ----
18Eh	ANSELC	ANSC<7:6> <sup>(2)</sup>			—	—	ANSC<3:0>			11-- 1111	11-- 1111	
18Fh	—	Unimplemented									—	—
190h	—	Unimplemented									—	—
191h	PMADRL	Program Memory Address Register Low Byte								0000 0000	0000 0000	
192h	PMADRH	— <sup>(1)</sup>	Program Memory Address Register High Byte								1000 0000	1000 0000
193h	PMDATL	Program Memory Read Data Register Low Byte								xxxx xxxx	uuuu uuuu	
194h	PMDATH	—	—	Program Memory Read Data Register High Byte						--xx xxxx	--uu uuuu	
195h	PMCON1	— <sup>(1)</sup>	CFG5	LWLO	FREE	WRERR	WREN	WR	RD	1000 x000	1000 q000	
196h	PMCON2	Program Memory Control Register 2								0000 0000	0000 0000	
197h	VREGCON <sup>(4)</sup>	—	—	—	—	—	—	VREGPM	Reserved	---- -001	---- -001	
198h	—	Unimplemented									—	—
199h	RC1REG	EUSART Receive Data Register								0000 0000	0000 0000	
19Ah	TX1REG	EUSART Transmit Data Register								0000 0000	0000 0000	
19Bh	SP1BRGL	SP1BRG<7:0>								0000 0000	0000 0000	
19Ch	SP1BRGH	SP1BRG<15:8>								0000 0000	0000 0000	
19Dh	RC1STA	SPEN	RX9	SREN	CREN	ADDEN	FERR	OERR	RX9D	0000 0000	0000 0000	
19Eh	TX1STA	CSRC	TX9	TXEN	SYNC	SENDB	BRGH	TRMT	TX9D	0000 0010	0000 0010	
19Fh	BAUD1CON	ABDOVF	RCIDL	—	SCKP	BRG16	—	WUE	ABDEN	01-0 0-00	01-0 0-00	

**Legend:** x = unknown; u = unchanged; q = value depends on condition; - = unimplemented, read as '0'; r = reserved.  
Shaded locations are unimplemented, read as '0'.

- Note**
- 1: Unimplemented, read as '1'.
  - 2: PIC16(L)F1768/9 only.
  - 3: PIC16(L)F1764/5 only.
  - 4: Unimplemented on PIC16LF1764/5/8/9.
  - 5: PIC16(L)F1768/9 only.

# PIC16(L)F1764/5/8/9

**TABLE 3-16: SPECIAL FUNCTION REGISTER SUMMARY (CONTINUED)**

Addr	Name	Bit 7	Bit 6	Bit 5	Bit 4	Bit 3	Bit 2	Bit 1	Bit 0	Value on POR, BOR	Value on All Other Resets	
<b>Bank 4</b>												
20Ch	WPUA	—	—	WPUA<5:0>						--11 1111	--11 1111	
20Dh	WPUB <sup>(2)</sup>	WPUB<7:4>						—	—	—	1111 ----	1111 ----
20Eh	WPUC	WPUC<7:6> <sup>(2)</sup>			WPUC<5:0>						1111 1111	1111 1111
20Fh	—	Unimplemented										
210h	—	Unimplemented										
211h	SSP1BUF	Synchronous Serial Port Receive Buffer/Transmit Register								xxxx xxxx	uuuu uuuu	
212h	SSP1ADD	ADD<7:0>								0000 0000	0000 0000	
213h	SSP1MSK	MSK<7:0>								1111 1111	1111 1111	
214h	SSP1STAT	SMP	CKE	D/A	P	S	R/W	UA	BF	0000 0000	0000 0000	
215h	SSP1CON1	WCOL	SSPOV	SSPEN	CKP	SSPM<3:0>				0000 0000	0000 0000	
216h	SSP1CON2	GCEN	ACKSTAT	ACKDT	ACKEN	RCEN	PEN	RSEN	SEN	0000 0000	0000 0000	
217h	SSP1CON3	ACKTIM	PCIE	SCIE	BOEN	SDAHT	SBCDE	AHEN	DHEN	0000 0000	0000 0000	
218h — 21Ch	—	Unimplemented										
21Dh	BORCON	SBOREN	BORFS	—	—	—	—	—	BORRDY	10-- ---q	uu-- ---u	
21Eh	FVRCON	FVREN	FVRDY	TSEN	TSRNG	CDAFVR<1:0>		ADFVR<1:0>		0q00 0000	0q00 0000	
21Fh	ZCD1CON	EN	—	OUT	POL	—	—	INTP	INTN	0-x0 --00	0-x0 --00	
<b>Bank 5</b>												
28Ch	ODCONA	—	—	ODA<5:4>			—	ODA<2:0>			--00 -000	--00 -000
28Dh	ODCONB <sup>(2)</sup>	ODB<7:4>						—	—	—	0000 ----	0000 ----
28Eh	ODCONC	ODC<7:6> <sup>(2)</sup>			ODC<5:0>						0000 0000	0000 0000
28Fh	—	Unimplemented										
290h	—	Unimplemented										
291h	CCPR1L	Capture/Compare/PWM Register 1 (LSB)								xxxx xxxx	uuuu uuuu	
292h	CCPR1H	Capture/Compare/PWM Register 1 (MSB)								xxxx xxxx	uuuu uuuu	
293h	CCP1CON	EN	—	OUT	FMT	MODE<3:0>				0-00 0000	0-00 0000	
294h	CCP1CAP	—	—	—	—	—	CTS<2:0>				---- -000	---- -000
295h — 297h	—	Unimplemented										
298h	CCPR2L <sup>(2)</sup>	Capture/Compare/PWM Register 2 (LSB)								xxxx xxxx	uuuu uuuu	
299h	CCPR2H <sup>(2)</sup>	Capture/Compare/PWM Register 2 (MSB)								xxxx xxxx	uuuu uuuu	
29Ah	CCP2CON <sup>(2)</sup>	EN	—	OUT	FMT	MODE<3:0>				0-00 0000	0-00 0000	
29Bh	CCP2CAP <sup>(2)</sup>	—	—	—	—	—	CTS<2:0>				---- -000	---- -000
29Ch — 29Dh	—	Unimplemented										
29Eh	CCPTMRS	P4TSEL<1:0> <sup>(2)</sup>			P3TSEL<1:0>		C2TSEL<1:0> <sup>(2)</sup>		C1TSEL<1:0>		0000 0000	0000 0000
29Fh	—	Unimplemented										

**Legend:** x = unknown; u = unchanged; q = value depends on condition; - = unimplemented, read as '0'; r = reserved.  
Shaded locations are unimplemented, read as '0'.

- Note**
- 1: Unimplemented, read as '1'.
  - 2: PIC16(L)F1768/9 only.
  - 3: PIC16(L)F1764/5 only.
  - 4: Unimplemented on PIC16LF1764/5/8/9.
  - 5: PIC16(L)F1768/9 only.

# PIC16(L)F1764/5/8/9

**TABLE 3-16: SPECIAL FUNCTION REGISTER SUMMARY (CONTINUED)**

Addr	Name	Bit 7	Bit 6	Bit 5	Bit 4	Bit 3	Bit 2	Bit 1	Bit 0	Value on POR, BOR	Value on All Other Resets	
<b>Bank 6</b>												
30Ch	SLRCONA	—	—	SLRA<5:4>		—	SLRA<2:0>			--11 -111	--11 -111	
30Dh	SLRCONB <sup>(2)</sup>	SLRB<7:4>				—	—	—	—	1111 ----	1111 ----	
30Eh	SLRCONC	SLRC<7:6> <sup>(2)</sup>		SLRC<5:0>						1111 1111	1111 1111	
30Fh — 31Ah	—	Unimplemented									—	—
31Bh	MD2CON0 <sup>(2)</sup>	EN	—	OUT	OPOL	—	—	—	BIT	0-00 ---0	0-00 ---0	
31Ch	MD2CON1 <sup>(2)</sup>	—	—	CHPOL	CHSYNC	—	—	CLPOL	CLSYNC	--00 --00	--00 --00	
31Dh	MD2SRC <sup>(2)</sup>	—	—	—	MS<4:0>				---	0000	---	0000
31Eh	MD2CARL <sup>(2)</sup>	—	—	—	—	CL<3:0>			----	0000	----	0000
31Fh	MD2CARH <sup>(2)</sup>	—	—	—	—	CH<3:0>			----	0000	----	0000
<b>Bank 7</b>												
38Ch	INLVLA	—	—	INLVLA<5:0>						--11 1111	--11 1111	
38Dh	INVLVB <sup>(2)</sup>	INVLVB<7:4>				—	—	—	—	1111 ----	1111 ----	
38Eh	INLVLC	INLVLC<7:6> <sup>(2)</sup>		INLVLC<5:0>						1111 1111	1111 1111	
38Fh	—	Unimplemented									—	—
390h	—	Unimplemented									—	—
391h	IOCAP	—	—	IOCAP<5:0>						--00 0000	--00 0000	
392h	IOCAN	—	—	IOCAN<5:0>						--00 0000	--00 0000	
393h	IOCAF	—	—	IOCAF<5:0>						--00 0000	--00 0000	
394h	IOCBP <sup>(2)</sup>	IOCBP<7:4>				—	—	—	—	0000 ----	0000 ----	
395h	IOCBN <sup>(2)</sup>	IOCBN<7:4>				—	—	—	—	0000 ----	0000 ----	
396h	IOCBF <sup>(2)</sup>	IOCBF<7:4>				—	—	—	—	0000 ----	0000 ----	
397h	IOCCP	IOCCP<7:6> <sup>(2)</sup>		IOCCP<5:0>						0000 0000	0000 0000	
398h	IOCCN	IOCCN<7:6> <sup>(2)</sup>		IOCCN<5:0>						0000 0000	0000 0000	
399h	IOCCF	IOCCF<7:6> <sup>(2)</sup>		IOCCF<5:0>						0000 0000	0000 0000	
39Ah	—	Unimplemented									—	—
39Bh	MD1CON0	EN	—	OUT	OPOL	—	—	—	BIT	0-00 ---0	0-00 ---0	
39Ch	MD1CON1	—	—	CHPOL	CHSYNC	—	—	CLPOL	CLSYNC	--00 --00	--00 --00	
39Dh	MD1SRC	—	—	—	MS<4:0>				---	0000	---	0000
39Eh	MD1CARL	—	—	—	—	CL<3:0>			----	0000	----	0000
39Fh	MD1CARH	—	—	—	—	CH<3:0>			----	0000	----	0000

**Legend:** x = unknown; u = unchanged; q = value depends on condition; - = unimplemented, read as '0'; r = reserved.  
Shaded locations are unimplemented, read as '0'.

- Note**
- 1: Unimplemented, read as '1'.
  - 2: PIC16(L)F1768/9 only.
  - 3: PIC16(L)F1764/5 only.
  - 4: Unimplemented on PIC16LF1764/5/8/9.
  - 5: PIC16(L)F1768/9 only.

# PIC16(L)F1764/5/8/9

**TABLE 3-16: SPECIAL FUNCTION REGISTER SUMMARY (CONTINUED)**

Addr	Name	Bit 7	Bit 6	Bit 5	Bit 4	Bit 3	Bit 2	Bit 1	Bit 0	Value on POR, BOR	Value on All Other Resets
<b>Bank 8</b>											
40Ch — 40Dh	—	Unimplemented								—	—
40Eh	HIDRVC	—	—	HIDC<5:4>		—	—	—	—	--00 ----	--00 ----
40Fh — 412h	—	Unimplemented								—	—
413h	T4TMR	Holding Register for the 8-Bit TMR4 Register								0000 0000	0000 0000
413h	T4PR	TMR4 Period Register								1111 1111	1111 1111
415h	T4CON	ON	CKPS<2:0>			OUTPS<3:0>			0000 0000	0000 0000	
416h	T4HLT	PSYNC	CKPOL	CKSYNC	MODE<4:0>			0000 0000	0000 0000		
417h	T4CLKCON	—	—	—	—	CS<3:0>			---- 0000	---- 0000	
418h	T4RST	—	—	—	—	RSEL<3:0>			---- 0000	---- 0000	
419h	—	Unimplemented								—	—
41Ah	T6TMR	Holding Register for the 8-Bit TMR4 Register								0000 0000	0000 0000
41Bh	T6PR	TMR4 Period Register								1111 1111	1111 1111
41Ch	T6CON	ON	CKPS<2:0>			OUTPS<3:0>			0000 0000	0000 0000	
41Dh	T6HLT	PSYNC	CKPOL	CKSYNC	MODE<4:0>			0000 0000	0000 0000		
41Eh	T6CLKCON	—	—	—	—	CS<3:0>			---- 0000	---- 0000	
41Fh	T6RST	—	—	—	—	RSEL<3:0>			---- 0000	---- 0000	
<b>Bank 9</b>											
48Ch to 492h	—	Unimplemented								—	—
493h	TMR3L	Holding Register for the Least Significant Byte of the 16-Bit TMR1 Register								xxxx xxxx	uuuu uuuu
494h	TMR3H	Holding Register for the Most Significant Byte of the 16-Bit TMR1 Register								xxxx xxxx	uuuu uuuu
495h	T3CON	CS<1:0>		CKPS<1:0>		OSCEN	SYNC	—	ON	0000 00-0	uuuu uu-u
496h	T3GCON	GE	GPOL	GTM	GSPM	GGO/DONE	GVAL	GSS<1:0>		0000 0x00	uuuu uxuu
497h to 499h	—	Unimplemented								—	—
49Ah	TMR5L	Holding Register for the Least Significant Byte of the 16-Bit TMR1 Register								xxxx xxxx	uuuu uuuu
49Bh	TMR5H	Holding Register for the Most Significant Byte of the 16-Bit TMR1 Register								xxxx xxxx	uuuu uuuu
49Ch	T5CON	CS<1:0>		CKPS<1:0>		OSCEN	SYNC	—	ON	0000 00-0	uuuu uu-u
49Dh	T5GCON	GE	GPOL	GTM	GSPM	GGO/DONE	GVAL	GSS<1:0>		0000 0x00	uuuu uxuu
49Eh to 49Fh	—	Unimplemented								—	—

**Legend:** x = unknown; u = unchanged; q = value depends on condition; - = unimplemented, read as '0'; r = reserved.  
Shaded locations are unimplemented, read as '0'.

- Note**
- 1: Unimplemented, read as '1'.
  - 2: PIC16(L)F1768/9 only.
  - 3: PIC16(L)F1764/5 only.
  - 4: Unimplemented on PIC16LF1764/5/8/9.
  - 5: PIC16(L)F1768/9 only.

# PIC16(L)F1764/5/8/9

**TABLE 3-16: SPECIAL FUNCTION REGISTER SUMMARY (CONTINUED)**

Addr	Name	Bit 7	Bit 6	Bit 5	Bit 4	Bit 3	Bit 2	Bit 1	Bit 0	Value on POR, BOR	Value on All Other Resets		
<b>Bank 10</b>													
50Ch — 50Eh	—	Unimplemented								—	—		
50Fh	OPA1NCHS	—	—	—	—	NCH<3:0>			----	0000	----	0000	
510h	OPA1PCHS	—	—	—	—	PCH<3:0>			----	0000	----	0000	
511h	OPA1CON	EN	—	—	UG	—	ORPOL	ORM<1:0>		0--0	-000	0--0	-000
512h	OPA1ORS	—	—	—	ORS<4:0>			---	0000	---	0000		
513h	OPA2NCHS <sup>(2)</sup>	—	—	—	—	NCH<3:0>			----	0000	----	0000	
514h	OPA2PCHS <sup>(2)</sup>	—	—	—	—	PCH<3:0>			----	0000	----	0000	
515h	OPA2CON <sup>(2)</sup>	EN	—	—	UG	—	ORPOL	ORM<1:0>		0--0	-000	0--0	-000
516h	OPA2ORS <sup>(2)</sup>	—	—	—	ORS<4:0>			---	0000	---	0000		
517h — 51Fh	—	Unimplemented								—	—		
<b>Bank 11</b>													
590h	DACL	---	---	---	---	---	---	DAC2LD <sup>(2)</sup>	DAC1LD	----	----	----	----
591h	DAC1CON0	EN	FM	OE1	---	PSS<1:0>		NSS<1:0>		000-	0000	000-	0000
592h	DAC1REFL	REF<7:0>								0000	0000	0000	0000
593h	DAC1REFH	REF<15:8>								0000	0000	0000	0000
594h	DAC2CON0 <sup>(2)</sup>	EN	FM	OE1	---	PSS<1:0>		NSS<1:0>		000-	0000	000-	0000
595h	DAC2REFL <sup>(2)</sup>	REF<7:0>								0000	0000	0000	0000
596h	DAC2REFH <sup>(2)</sup>	REF<15:8>								0000	0000	0000	0000
597h	DAC3CON0	EN	---	OE1	---	PSS<1:0>		NSS<1:0>		0-0-	0000	0-0-	0000
598h	DAC3REF	---	---	---	REF<4:0>			---	0000	---	0000		
599h	DAC4CON0 <sup>(2)</sup>	EN	---	OE1	---	PSS<1:0>		NSS<1:0>		0-0-	0000	0-0-	0000
59Ah	DAC4REF <sup>(2)</sup>	---	---	---	REF<4:0>			---	0000	---	0000		
59Bh to 59Fh	—	Unimplemented								—	—		

**Legend:** x = unknown; u = unchanged; q = value depends on condition; - = unimplemented, read as '0'; r = reserved.  
Shaded locations are unimplemented, read as '0'.

- Note**
- 1: Unimplemented, read as '1'.
  - 2: PIC16(L)F1768/9 only.
  - 3: PIC16(L)F1764/5 only.
  - 4: Unimplemented on PIC16LF1764/5/8/9.
  - 5: PIC16(L)F1768/9 only.

# PIC16(L)F1764/5/8/9

**TABLE 3-16: SPECIAL FUNCTION REGISTER SUMMARY (CONTINUED)**

Addr	Name	Bit 7	Bit 6	Bit 5	Bit 4	Bit 3	Bit 2	Bit 1	Bit 0	Value on POR, BOR	Value on All Other Resets	
<b>Bank 12</b>												
60Ch to 616h	—	Unimplemented								—	—	
617h	PWM3DCL	DC<1:0>		—	—	—	—	—	—	xx-- ----	uu-- ----	
618h	PWM3DCH	DC<9:2>								xxxx xxxx	uuuu uuuu	
619h	PWM3CON	EN	—	OUT	POL	—	—	—	—	0-00 ----	0-00 ----	
61Ah	PWM4DCL <sup>(2)</sup>	DC<1:0>		—	—	—	—	—	—	00-- ----	uu-- ----	
61Bh	PWM4DCH <sup>(2)</sup>	DC<9:2>								0000 0000	uuuu uuuu	
61Ch	PWM4CON <sup>(2)</sup>	EN	—	OUT	POL	—	—	—	—	0-00 ----	0-00 ----	
61Dh — 61Fh	—	Unimplemented								—	—	
<b>Bank 13</b>												
68Ch	—	Unimplemented								—	—	
68Dh	COG1PHR	—	—	COG Rising Edge Phase Delay Count Register							--00 0000	--00 0000
68Eh	COG1PHF	—	—	COG Falling Edge Phase Delay Count Register							--00 0000	--00 0000
68Fh	COG1BLKR	—	—	COG Rising Edge Blanking Count Register							--00 0000	--00 0000
690h	COG1BLKF	—	—	COG Falling Edge Blanking Count Register							--00 0000	--00 0000
691h	COG1DBR	—	—	COG Rising Edge Dead-band Count Register							--00 0000	--00 0000
692h	COG1DBF	—	—	COG Falling Edge Dead-band Count Register							--00 0000	--00 0000
693h	COG1CON0	EN	LD	—	CS<1:0>		MD<2:0>			00-0 0000	00-0 0000	
694h	COG1CON1	RDBS	FDBS	—	—	POLD	POLC	POLB	POLA	00-- 0000	00-- 0000	
695h	COG1RIS0	RIS<7:0>								0000 0000	0000 0000	
696h	COG1RIS1	RIS15 <sup>(2)</sup>	RIS<14:8>							0000 0000	0000 0000	
697h	COG1RSIM0	RSIM<7:0>								0000 0000	0000 0000	
698h	COG1RSIM1	RSIM15 <sup>(2)</sup>	RSIM<14:8>							0000 0000	0000 0000	
699h	COG1FIS0	FIS<7:0>								0000 0000	0000 0000	
69Ah	COG1FIS1	FIS15 <sup>(2)</sup>	FIS<14:8>							0000 0000	0000 0000	
69Bh	COG1FSIM0	FSIM<7:0>								0000 0000	0000 0000	
69Ch	COG1FSIM1	FSIM15 <sup>(2)</sup>	FSIM<14:8>							0000 0000	0000 0000	
69Dh	COG1ASD0	ASE	ARSEN	ASDBD<1:0>		ASDAC<1:0>		—	—	0001 01--	0001 01--	
69Eh	COG1ASD1	AS7E	AS6E	AS5E	AS4E	AS3E	AS2E	AS1E	AS0E	0000 0000	0000 0000	
69Fh	COG1STR	SDATD	SDATC	SDATB	SDATA	STRD	STRC	STRB	STRA	0000 0000	0000 0000	

**Legend:** x = unknown; u = unchanged; q = value depends on condition; - = unimplemented, read as '0'; r = reserved.  
Shaded locations are unimplemented, read as '0'.

- Note**
- 1: Unimplemented, read as '1'.
  - 2: PIC16(L)F1768/9 only.
  - 3: PIC16(L)F1764/5 only.
  - 4: Unimplemented on PIC16LF1764/5/8/9.
  - 5: PIC16(L)F1768/9 only.



# PIC16(L)F1764/5/8/9

**TABLE 3-16: SPECIAL FUNCTION REGISTER SUMMARY (CONTINUED)**

Addr	Name	Bit 7	Bit 6	Bit 5	Bit 4	Bit 3	Bit 2	Bit 1	Bit 0	Value on POR, BOR	Value on All Other Resets		
<b>Bank 14</b>													
70Ch	—	Unimplemented								—	—		
70Dh	COG2PHR <sup>(2)</sup>	—	—	COG Rising Edge Phase Delay Count Register								--00 0000	--00 0000
70Eh	COG2PHF <sup>(2)</sup>	—	—	COG Falling Edge Phase Delay Count Register								--00 0000	--00 0000
70Fh	COG2BLKR <sup>(2)</sup>	—	—	COG Rising Edge Blanking Count Register								--00 0000	--00 0000
710h	COG2BLKF <sup>(2)</sup>	—	—	COG Falling Edge Blanking Count Register								--00 0000	--00 0000
711h	COG2DBR <sup>(2)</sup>	—	—	COG Rising Edge Dead-band Count Register								--00 0000	--00 0000
712h	COG2DBF <sup>(2)</sup>	—	—	COG Falling Edge Dead-band Count Register								--00 0000	--00 0000
713h	COG2CON0 <sup>(2)</sup>	EN	LD	—	CS<1:0>		MD<2:0>			00-0 0000	00-0 0000		
714h	COG2CON1 <sup>(2)</sup>	RDBS	FDBS	—	—	POLD	POLC	POLB	POLA	00-- 0000	00-- 0000		
715h	COG2RIS0 <sup>(2)</sup>	RIS<7:0>								0000 0000	0000 0000		
716h	COG2RIS1 <sup>(2)</sup>	RIS<15:8>								0000 0000	0000 0000		
717h	COG2RSIM0 <sup>(2)</sup>	RSIM<7:0>								0000 0000	0000 0000		
718h	COG2RSIM1 <sup>(2)</sup>	RSIM<15:8>								0000 0000	0000 0000		
719h	COG2FIS0 <sup>(2)</sup>	FIS<7:0>								0000 0000	0000 0000		
71Ah	COG2FIS1 <sup>(2)</sup>	FIS<15:8>								0000 0000	0000 0000		
71Bh	COG2FSIM0 <sup>(2)</sup>	FSIM<7:0>								0000 0000	0000 0000		
71Ch	COG2FSIM1 <sup>(2)</sup>	FSIM<15:8>								0000 0000	0000 0000		
71Dh	COG2ASD0 <sup>(2)</sup>	ASE	ARSEN	ASDBD<1:0>		ASDAC<1:0>		—	—	0001 01--	0001 01--		
71Eh	COG2ASD1 <sup>(2)</sup>	AS7E	AS6E	AS5E	AS4E	AS3E	AS2E	AS1E	AS0E	0000 0000	0000 0000		
71Fh	COG2STR <sup>(2)</sup>	SDATD	SDATC	SDATB	SDATA	STRD	STRC	STRB	STRA	0000 0000	0000 0000		
<b>Bank 15</b>													
78Ch — 793h	—	Unimplemented								—	—		
794h	PRG1RTSS	—	—	—	—	RTSS<3:0>					---- 0000	---- 0000	
795h	PRG1FTSS	—	—	—	—	FTSS<3:0>					---- 0000	---- 0000	
796h	PRG1INS	—	—	—	—	INS<3:0>					---- 0000	---- 0000	
797h	PRG1CON0	EN	—	FEDG	REDG	MODE<1:0>		OS	GO	0-00 0000	0-00 0000		
798h	PRG1CON1	—	—	—	—	—	RDY	FPOL	RPOL	---- -000	---- -000		
799h	PRG1CON2	LR <sup>(5)</sup>	—	—	ISET<4:0>						0--0 0000	0--0 0000	
79Ah	PRG2RTSS <sup>(2)</sup>	—	—	—	—	RTSS<3:0>					---- 0000	---- 0000	
79Bh	PRG2FTSS <sup>(2)</sup>	—	—	—	—	FTSS<3:0>					---- 0000	---- 0000	
79Ch	PRG2INS <sup>(2)</sup>	—	—	—	—	INS<3:0>					---- 0000	---- 0000	
79Dh	PRG2CON0 <sup>(2)</sup>	EN	—	FEDG	REDG	MODE<1:0>		OS	GO	0-00 0000	0-00 0000		
79Eh	PRG2CON1 <sup>(2)</sup>	—	—	—	—	—	RDY	FPOL	RPOL	---- -000	---- -000		
79Fh	PRG2CON2 <sup>(2)</sup>	LR <sup>(5)</sup>	—	—	ISET<4:0>						0--0 0000	0--0 0000	
<b>Bank 16-26</b>													
x0Ch/ x8Ch — x1Fh/ x9Fh	—	Unimplemented								—	—		

**Legend:** x = unknown; u = unchanged; q = value depends on condition; - = unimplemented, read as '0'; x = reserved.  
Shaded locations are unimplemented, read as '0'.

- Note**
- 1: Unimplemented, read as '1'.
  - 2: PIC16(L)F1768/9 only.
  - 3: PIC16(L)F1764/5 only.
  - 4: Unimplemented on PIC16LF1764/5/8/9.
  - 5: PIC16(L)F1768/9 only.

# PIC16(L)F1764/5/8/9

**TABLE 3-16: SPECIAL FUNCTION REGISTER SUMMARY (CONTINUED)**

Addr	Name	Bit 7	Bit 6	Bit 5	Bit 4	Bit 3	Bit 2	Bit 1	Bit 0	Value on POR, BOR	Value on All Other Resets	
<b>Bank 27</b>												
D8Ch — D8Dh	—	Unimplemented								—	—	
D8Eh	PWMEN	—	—	MPWM6EN <sup>(2)</sup>	MPWM5EN	—	—	—	—	--00 ----	--00 ----	
D8Fh	PWMLD	—	—	MPWM6LD <sup>(2)</sup>	MPWM5LD	—	—	—	—	--00 ----	--00 ----	
D90h	PWMOUT	—	—	MPWM6OUT <sup>(2)</sup>	MPWM5OUT	—	—	—	—	--00 ----	--00 ----	
D91h	PWM5PHL	PH<7:0>								xxxx xxxx	uuuu uuuu	
D92h	PWM5PHH	PH<15:8>								xxxx xxxx	uuuu uuuu	
D93h	PWM5DCL	DC<7:0>								xxxx xxxx	uuuu uuuu	
D94h	PWM5DCH	DC<15:8>								xxxx xxxx	uuuu uuuu	
D95h	PWM5PRL	PR<7:0>								xxxx xxxx	uuuu uuuu	
D96h	PWM5PRH	PR<15:8>								xxxx xxxx	uuuu uuuu	
D97h	PWM5OFL	OF<7:0>								xxxx xxxx	uuuu uuuu	
D98h	PWM5OFH	OF<15:8>								xxxx xxxx	uuuu uuuu	
D99h	PWM5TMRL	TMR<7:0>								0000 0000	0000 0000	
D9Ah	PWM5TMRH	TMR<15:8>								0000 0000	0000 0000	
D9Bh	PWM5CON	EN	—	OUT	POL	MODE<1:0>		—	—	0-00 00--	0-00 00--	
D9Ch	PWM5INTE	—	—	—	—	OFIE	PHIE	DCIE	PRIE	---- 0000	---- 0000	
D9Dh	PWM5INTF	—	—	—	—	OFIF	PHIF	DCIF	PRIF	---- 0000	---- 0000	
D9Eh	PWM5CLKCON	—	PS<2:0>				—	—	CS<1:0>		-000 --00	-000 --00
D9Fh	PWM5LDCON	LDA	LDT <sup>(2)</sup>	—	—	—	—	—	LDS <sup>(2)</sup>	00-- ---0	00-- ---0	
DA0h	PWM5OFCON	—	OFM<1:0> <sup>(2)</sup>		OFO	—	—	—	OFS <sup>(2)</sup>	-000 ---0	-000 ---0	
DA1h	PWM6PHL <sup>(2)</sup>	PH<7:0>								xxxx xxxx	uuuu uuuu	
DA2h	PWM6PHH <sup>(2)</sup>	PH<15:8>								xxxx xxxx	uuuu uuuu	
DA3h	PWM6DCL <sup>(2)</sup>	DC<7:0>								xxxx xxxx	uuuu uuuu	
DA4h	PWM6DCH <sup>(2)</sup>	DC<15:8>								xxxx xxxx	uuuu uuuu	
DA5h	PWM6PRL <sup>(2)</sup>	PR<7:0>								xxxx xxxx	uuuu uuuu	
DA6h	PWM6PRH <sup>(2)</sup>	PR<15:8>								xxxx xxxx	uuuu uuuu	
DA7h	PWM6OFL <sup>(2)</sup>	OF<7:0>								xxxx xxxx	uuuu uuuu	
DA8h	PWM6OFH <sup>(2)</sup>	OF<15:8>								xxxx xxxx	uuuu uuuu	
DA9h	PWM6TMRL <sup>(2)</sup>	TMR<7:0>								0000 0000	0000 0000	
DAAh	PWM6TMRH <sup>(2)</sup>	TMR<15:8>								0000 0000	0000 0000	
DABh	PWM6CON <sup>(2)</sup>	EN	—	OUT	POL	MODE<1:0>		—	—	0-00 00--	0-00 00--	
DACH	PWM6INTE <sup>(2)</sup>	—	—	—	—	OFIE	PHIE	DCIE	PRIE	---- 0000	---- 0000	
DADh	PWM6INTF <sup>(2)</sup>	—	—	—	—	OFIF	PHIF	DCIF	PRIF	---- 0000	---- 0000	
DAEh	PWM6CLKCON <sup>(2)</sup>	—	PS<2:0>				—	—	CS<1:0>		-000 --00	-000 --00
DAFh	PWM6LDCON <sup>(2)</sup>	LDA	LDT	—	—	—	—	—	LDS	00-- ---0	00-- ---0	
DB0h	PWM6OFCON <sup>(2)</sup>	—	OFM<1:0>		OFO	—	—	—	OFS	-000 ---0	-000 ---0	
DB1h to DBFh	—	Unimplemented								—	—	

**Legend:** x = unknown; u = unchanged; q = value depends on condition; - = unimplemented, read as '0'; r = reserved.  
Shaded locations are unimplemented, read as '0'.

- Note**
- 1: Unimplemented, read as '1'.
  - 2: PIC16(L)F1768/9 only.
  - 3: PIC16(L)F1764/5 only.
  - 4: Unimplemented on PIC16LF1764/5/8/9.
  - 5: PIC16(L)F1768/9 only.

# PIC16(L)F1764/5/8/9

**TABLE 3-16: SPECIAL FUNCTION REGISTER SUMMARY (CONTINUED)**

Addr	Name	Bit 7	Bit 6	Bit 5	Bit 4	Bit 3	Bit 2	Bit 1	Bit 0	Value on POR, BOR	Value on All Other Resets
<b>Bank 28</b>											
E0Ch — E0Eh	—	Unimplemented								—	—
E0Fh	PPSLOCK	—	—	—	—	—	—	—	PPSLOCKED	---- --0	---- --0
E10h	INTPPS	—	—	—	INTPPS<4:0>					---0 0010	---u uuuu
E11h	T0CKIPPS	—	—	—	T0CKIPPS<4:0>					---0 0010	---u uuuu
E12h	T1CKIPPS	—	—	—	T1CKIPPS<4:0>					---0 0101	---u uuuu
E13h	T1GPPS	—	—	—	T1GPPS<4:0>					---0 0100	---u uuuu
E14h	CCP1PPS	—	—	—	CCP1PPS<4:0>					---1 0101	---u uuuu
E15h	CCP2PPS <sup>(2)</sup>	—	—	—	CCP2PPS<4:0>					---1 0011	---u uuuu
E16h	COG1INPPS	—	—	—	COG1INPPS<4:0>					---0 0010	---u uuuu
E17h	COG2INPPS <sup>(2)</sup>	—	—	—	COG2INPPS<4:0>					---0 0010	---u uuuu
E18h	—	Unimplemented								—	—
E19h	T2INPPS	—	—	—	T2INPPS<4:0>					---0 0101	---u uuuu
E1Ah	T3CKIPPS	—	—	—	T3CKIPPS<4:0>					---1 0101	---u uuuu
E1Bh	T3GPPS	—	—	—	T3GPPS<4:0>					---1 0100	---u uuuu
E1Ch	T4INPPS	—	—	—	T4INPPS<4:0>					---1 0001	---u uuuu
E1Dh	T5CKIPPS	—	—	—	T5CKIPPS<4:0>					---1 0000	---u uuuu
E1Eh	T5GPPS	—	—	—	T5GPPS<4:0>					---1 0011	---u uuuu
E1Fh	T6INPPS	—	—	—	T6INPPS<4:0>					---0 0011	---u uuuu
E20h	SSPCLKPPS	SSPCLKPPS<4:0>								---1 0000 <sup>(3)</sup>	---u uuuu
		SSPCLKPPS<4:0>								---0 1110 <sup>(2)</sup>	---u uuuu
E21h	SSPDATPPS	SSPDATPPS<4:0>								---1 0001 <sup>(3)</sup>	---u uuuu
		SSPDATPPS<4:0>								---0 1100 <sup>(2)</sup>	---u uuuu
E22h	SSPSSPPS	SSPSSPPS<4:0>								---1 0011 <sup>(3)</sup>	---u uuuu
		SSPSSPPS<4:0>								---1 0110 <sup>(2)</sup>	---u uuuu
E23h	—	Unimplemented								—	—
E24h	RXPPS	RXPPS<4:0>								---1 0101 <sup>(3)</sup>	---u uuuu
		RXPPS<4:0>								---0 1101 <sup>(2)</sup>	---u uuuu
E25h	CKPPS	CKPPS<4:0>								---1 0100 <sup>(3)</sup>	---u uuuu
		CKPPS<4:0>								---0 1111 <sup>(2)</sup>	---u uuuu
E26h	—	Unimplemented								—	—
E27h	—	Unimplemented								—	—
E28h	CLCIN0PPS	—	—	—	CLCIN0PPS<4:0>					---1 0011	---u uuuu
E29h	CLCIN1PPS	—	—	—	CLCIN1PPS<4:0>					---1 0100	---u uuuu
E2Ah	CLCIN2PPS	—	—	—	CLCIN2PPS<4:0>					---1 0001	---u uuuu
E2Bh	CLCIN3PPS	—	—	—	CLCIN3PPS<4:0>					---0 0101	---u uuuu
E2Ch	PRG1RPPS	—	—	—	PRG1RPPS<4:0>					---1 0100	---u uuuu
E2Dh	PRG1FPPS	—	—	—	PRG1FPPS<4:0>					---1 0101	---u uuuu
E2Eh	PRG2RPPS <sup>(2)</sup>	—	—	—	PRG2RPPS<4:0>					---1 0100	---u uuuu
E2Fh	PRG2FPPS <sup>(2)</sup>	—	—	—	PRG2FPPS<4:0>					---1 0101	---u uuuu
E30h	MD1CHPPS	—	—	—	MD1CHPPS<4:0>					---0 0011	---u uuuu
E31h	MD1CLPPS	—	—	—	MD1CLPPS<4:0>					---0 0100	---u uuuu

**Legend:** x = unknown; u = unchanged; q = value depends on condition; - = unimplemented, read as '0'; r = reserved.  
Shaded locations are unimplemented, read as '0'.

- Note**
- 1: Unimplemented, read as '1'.
  - 2: PIC16(L)F1768/9 only.
  - 3: PIC16(L)F1764/5 only.
  - 4: Unimplemented on PIC16LF1764/5/8/9.
  - 5: PIC16(L)F1768/9 only.

# PIC16(L)F1764/5/8/9

**TABLE 3-16: SPECIAL FUNCTION REGISTER SUMMARY (CONTINUED)**

Addr	Name	Bit 7	Bit 6	Bit 5	Bit 4	Bit 3	Bit 2	Bit 1	Bit 0	Value on POR, BOR	Value on All Other Resets
<b>Bank 28 (Continued)</b>											
E32h	MD1MODPPS	—	—	—	MD1MODPPS<4:0>			---	0101	---u	uuuu
E33h	MD2CHPPS <sup>(2)</sup>	—	—	—	MD2CHPPS<4:0>			---	0011	---u	uuuu
E34h	MD2CLPPS <sup>(2)</sup>	—	—	—	MD2CLPPS<4:0>			---	0100	---u	uuuu
E35h	MD2MODPPS <sup>(2)</sup>	—	—	—	MD2MODPPS<4:0>			---	0101	---u	uuuu
E36h to E7Fh	—	Unimplemented								—	—
<b>Bank 29</b>											
E8Ch — E8Fh	—	Unimplemented								—	—
E90h	RA0PPS	—	—	—	RA0PPS<4:0>			---	0000	---u	uuuu
E91h	RA1PPS	—	—	—	RA1PPS<4:0>			---	0000	---u	uuuu
E92h	RA2PPS	—	—	—	RA2PPS<4:0>			---	0000	---u	uuuu
E93h	—	Unimplemented								—	—
E94h	RA4PPS	—	—	—	RA4PPS<4:0>			---	0000	---u	uuuu
E95h	RA5PPS	—	—	—	RA5PPS<4:0>			---	0000	---u	uuuu
E96h	—	Unimplemented								—	—
E97h	—	Unimplemented								—	—
E98h	—	Unimplemented								—	—
E99h	—	Unimplemented								—	—
E9Ah	—	Unimplemented								—	—
E9Bh	—	Unimplemented								—	—
E9Ch	RB4PPS <sup>(2)</sup>	—	—	—	RB4PPS<4:0>			---	0000	---u	uuuu
E9Dh	RB5PPS <sup>(2)</sup>	—	—	—	RB5PPS<4:0>			---	0000	---u	uuuu
E9Eh	RB6PPS <sup>(2)</sup>	—	—	—	RB6PPS<4:0>			---	0000	---u	uuuu
E9Fh	RB7PPS <sup>(2)</sup>	—	—	—	RB7PPS<4:0>			---	0000	---u	uuuu
EA0h	RC0PPS	—	—	—	RC0PPS<4:0>			---	0000	---u	uuuu
EA1h	RC1PPS	—	—	—	RC1PPS<4:0>			---	0000	---u	uuuu
EA2h	RC2PPS	—	—	—	RC2PPS<4:0>			---	0000	---u	uuuu
EA3h	RC3PPS	—	—	—	RC3PPS<4:0>			---	0000	---u	uuuu
EA4h	RC4PPS	—	—	—	RC4PPS<4:0>			---	0000	---u	uuuu
EA5h	RC5PPS	—	—	—	RC5PPS<4:0>			---	0000	---u	uuuu
EA6h	RC6PPS <sup>(2)</sup>	—	—	—	RC6PPS<4:0>			---	0000	---u	uuuu
EA7h	RC7PPS <sup>(2)</sup>	—	—	—	RC7PPS<4:0>			---	0000	---u	uuuu
EA8h — EEFh	—	Unimplemented								—	—

**Legend:** x = unknown; u = unchanged; q = value depends on condition; - = unimplemented, read as '0'; r = reserved.  
Shaded locations are unimplemented, read as '0'.

- Note**
- 1: Unimplemented, read as '1'.
  - 2: PIC16(L)F1768/9 only.
  - 3: PIC16(L)F1764/5 only.
  - 4: Unimplemented on PIC16LF1764/5/8/9.
  - 5: PIC16(L)F1768/9 only.

# PIC16(L)F1764/5/8/9

**TABLE 3-16: SPECIAL FUNCTION REGISTER SUMMARY (CONTINUED)**

Addr	Name	Bit 7	Bit 6	Bit 5	Bit 4	Bit 3	Bit 2	Bit 1	Bit 0	Value on POR, BOR	Value on All Other Resets	
<b>Bank 30</b>												
F0Ch — F0Eh	—	Unimplemented								—	—	
F0Fh	CLCDATA	—	—	—	—	—	MLC3OUT	MLC2OUT	MLC1OUT	---- -000	---- -000	
F10h	CLC1CON	EN	—	OUT	INTP	INTN	MODE<2:0>			0-00 0000	0-00 0000	
F11h	CLC1POL	POL	—	—	—	G4POL	G3POL	G2POL	G1POL	0--- xxxx	0--- uuuu	
F12h	CLC1SEL0	—	—	—	D1S<4:0>						---x xxxx	---u uuuu
F13h	CLC1SEL1	—	—	—	D2S<4:0>						---x xxxx	---u uuuu
F14h	CLC1SEL2	—	—	—	D3S<4:0>						---x xxxx	---u uuuu
F15h	CLC1SEL3	—	—	—	D4S<4:0>						---x xxxx	---u uuuu
F16h	CLC1GLS0	G1D4T	G1D4N	G1D3T	G1D3N	G1D2T	G1D2N	G1D1T	G1D1N	xxxx xxxx	uuuu uuuu	
F17h	CLC1GLS1	G2D4T	G2D4N	G2D3T	G2D3N	G2D2T	G2D2N	G2D1T	G2D1N	xxxx xxxx	uuuu uuuu	
F18h	CLC1GLS2	G3D4T	G3D4N	G3D3T	G3D3N	G3D2T	G3D2N	G3D1T	G3D1N	xxxx xxxx	uuuu uuuu	
F19h	CLC1GLS3	G4D4T	G4D4N	G4D3T	G4D3N	G4D2T	G4D2N	G4D1T	G4D1N	xxxx xxxx	uuuu uuuu	
F1Ah	CLC2CON	EN	—	OUT	INTP	INTN	MODE<2:0>			0-00 0000	0-00 0000	
F1Bh	CLC2POL	POL	—	—	—	G4POL	G3POL	G2POL	G1POL	0--- xxxx	0--- uuuu	
F1Ch	CLC2SEL0	—	—	—	D1S<4:0>						---x xxxx	---u uuuu
F1Dh	CLC2SEL1	—	—	—	D2S<4:0>						---x xxxx	---u uuuu
F1Eh	CLC2SEL2	—	—	—	D3S<4:0>						---x xxxx	---u uuuu
F1Fh	CLC2SEL3	—	—	—	D4S<4:0>						---x xxxx	---u uuuu
F20h	CLC2GLS0	G1D4T	G1D4N	G1D3T	G1D3N	G1D2T	G1D2N	G1D1T	G1D1N	xxxx xxxx	uuuu uuuu	
F21h	CLC2GLS1	G2D4T	G2D4N	G2D3T	G2D3N	G2D2T	G2D2N	G2D1T	G2D1N	xxxx xxxx	uuuu uuuu	
F22h	CLC2GLS2	G3D4T	G3D4N	G3D3T	G3D3N	G3D2T	G3D2N	G3D1T	G3D1N	xxxx xxxx	uuuu uuuu	
F23h	CLC2GLS3	G4D4T	G4D4N	G4D3T	G4D3N	G4D2T	G4D2N	G4D1T	G4D1N	xxxx xxxx	uuuu uuuu	
F24h	CLC3CON	EN	—	OUT	INTP	INTN	MODE<2:0>			0-00 0000	0-00 0000	
F25h	CLC3POL	POL	—	—	—	G4POL	G3POL	G2POL	G1POL	0--- xxxx	0--- uuuu	
F26h	CLC3SEL0	—	—	—	D1S<4:0>						---x xxxx	---u uuuu
F27h	CLC3SEL1	—	—	—	D2S<4:0>						---x xxxx	---u uuuu
F28h	CLC3SEL2	—	—	—	D3S<4:0>						---x xxxx	---u uuuu
F29h	CLC3SEL3	—	—	—	D4S<4:0>						---x xxxx	---u uuuu
F2Ah	CLC3GLS0	G1D4T	G1D4N	G1D3T	G1D3N	G1D2T	G1D2N	G1D1T	G1D1N	xxxx xxxx	uuuu uuuu	
F2Bh	CLC3GLS1	G2D4T	G2D4N	G2D3T	G2D3N	G2D2T	G2D2N	G2D1T	G2D1N	xxxx xxxx	uuuu uuuu	
F2Ch	CLC3GLS2	G3D4T	G3D4N	G3D3T	G3D3N	G3D2T	G3D2N	G3D1T	G3D1N	xxxx xxxx	uuuu uuuu	
F2Dh	CLC3GLS3	G4D4T	G4D4N	G4D3T	G4D3N	G4D2T	G4D2N	G4D1T	G4D1N	xxxx xxxx	uuuu uuuu	
F2Eh — F6Fh	—	Unimplemented								—	—	

**Legend:** x = unknown; u = unchanged; q = value depends on condition; - = unimplemented, read as '0'; r = reserved.  
Shaded locations are unimplemented, read as '0'.

- Note**
- 1: Unimplemented, read as '1'.
  - 2: PIC16(L)F1768/9 only.
  - 3: PIC16(L)F1764/5 only.
  - 4: Unimplemented on PIC16LF1764/5/8/9.
  - 5: PIC16(L)F1768/9 only.

# PIC16(L)F1764/5/8/9

**TABLE 3-16: SPECIAL FUNCTION REGISTER SUMMARY (CONTINUED)**

Addr	Name	Bit 7	Bit 6	Bit 5	Bit 4	Bit 3	Bit 2	Bit 1	Bit 0	Value on POR, BOR	Value on All Other Resets	
<b>Bank 31</b>												
F8Ch to FE3h	—	Unimplemented								—	—	
FE4h	STATUS_SHAD	—	—	—	—	—	Z	DC	C	---- -xxx	---- -uuu	
FE5h	WREG_SHAD	Working Register Shadow								xxxx xxxx	uuuu uuuu	
FE6h	BSR_SHAD	—	—	—	Bank Select Register Shadow				---	xxxx	---u uuuu	
FE7h	PCLATH_SHAD	—	Program Counter Latch High Register Shadow								-xxx xxxx	-uuu uuuu
FE8h	FSR0L_SHAD	Indirect Data Memory Address 0 Low Pointer Shadow								xxxx xxxx	uuuu uuuu	
FE9h	FSR0H_SHAD	Indirect Data Memory Address 0 High Pointer Shadow								xxxx xxxx	uuuu uuuu	
FEAh	FSR1L_SHAD	Indirect Data Memory Address 1 Low Pointer Shadow								xxxx xxxx	uuuu uuuu	
FEBh	FSR1H_SHAD	Indirect Data Memory Address 1 High Pointer Shadow								xxxx xxxx	uuuu uuuu	
FECh	—	Unimplemented								—	—	
FEDh	STKPTR	—	—	—	Current Stack Pointer				---1 1111	---1 1111		
FEEh	TOSL	Top of Stack Low byte								xxxx xxxx	uuuu uuuu	
FEFh	TOSH	—	Top of Stack High Byte								-xxx xxxx	-uuu uuuu

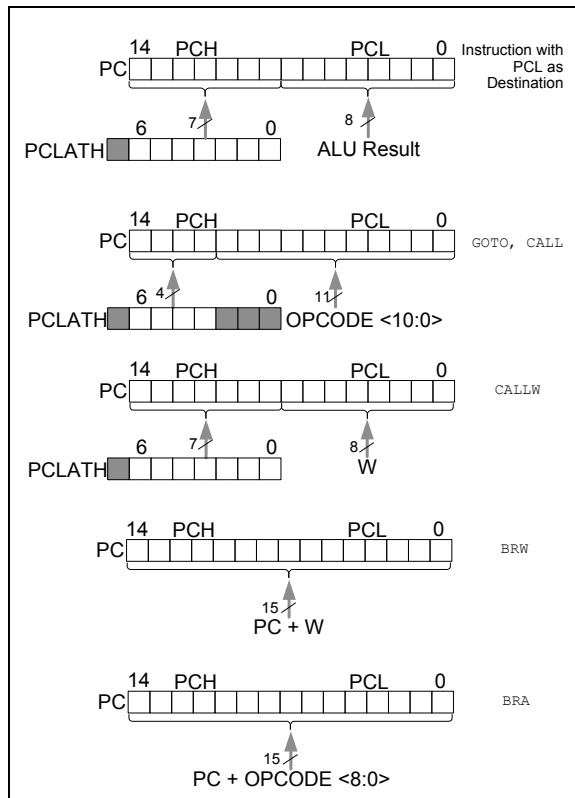
**Legend:** x = unknown; u = unchanged; q = value depends on condition; - = unimplemented, read as '0'; r = reserved.  
Shaded locations are unimplemented, read as '0'.

- Note**
- 1: Unimplemented, read as '1'.
  - 2: PIC16(L)F1768/9 only.
  - 3: PIC16(L)F1764/5 only.
  - 4: Unimplemented on PIC16LF1764/5/8/9.
  - 5: PIC16(L)F1768/9 only.

## 3.4 PCL and PCLATH

The Program Counter (PC) is 15 bits wide. The low byte comes from the PCL register, which is a readable and writable register. The high byte (PC<14:8>) is not directly readable or writable and comes from PCLATH. On any Reset, the PC is cleared. Figure 3-3 shows the five situations for the loading of the PC.

**FIGURE 3-3: LOADING OF PC IN DIFFERENT SITUATIONS**



### 3.4.1 MODIFYING PCL

Executing any instruction with the PCL register as the destination simultaneously causes the Program Counter PC<14:8> bits (PCH) to be replaced by the contents of the PCLATH register. This allows the entire contents of the Program Counter to be changed by writing the desired upper seven bits to the PCLATH register. When the lower eight bits are written to the PCL register, all 15 bits of the Program Counter will change to the values contained in the PCLATH register and those being written to the PCL register.

### 3.4.2 COMPUTED GOTO

A computed GOTO is accomplished by adding an offset to the Program Counter (ADDWF PCL). When performing a table read using a computed GOTO method, care should be exercised if the table location crosses a PCL memory boundary (each 256-byte block). Refer to Application Note AN556, "Implementing a Table Read" (DS00556).

### 3.4.3 COMPUTED FUNCTION CALLS

A computed function CALL allows programs to maintain tables of functions and provide another way to execute state machines or look-up tables. When performing a table read using a computed function CALL, care should be exercised if the table location crosses a PCL memory boundary (each 256-byte block).

If using the CALL instruction, the PCH<2:0> and PCL registers are loaded with the operand of the CALL instruction. PCH<6:3> is loaded with PCLATH<6:3>.

The CALLW instruction enables computed calls by combining PCLATH and W to form the destination address. A computed CALLW is accomplished by loading the W register with the desired address and executing CALLW. The PCL register is loaded with the value of W and PCH is loaded with PCLATH.

### 3.4.4 BRANCHING

The branching instructions add an offset to the PC. This allows relocatable code and code that crosses page boundaries. There are two forms of branching, BRW and BRA. The PC will have incremented to fetch the next instruction in both cases. When using either branching instruction, a PCL memory boundary may be crossed.

If using BRW, load the W register with the desired unsigned address and execute BRW. The entire PC will be loaded with the address PC + 1 + W.

If using BRA, the entire PC will be loaded with PC + 1 +, the signed value of the operand of the BRA instruction.

## 3.5 Stack

All devices have a 16-level x 15-bit wide hardware stack (refer to [Figure 3-1](#)). The stack space is not part of either program or data space. The PC is PUSHed onto the stack when `CALL` or `CALLW` instructions are executed or an interrupt causes a branch. The stack is POPed in the event of a `RETURN`, `RETLW` or a `RETFIE` instruction execution. `PCLATH` is not affected by a `PUSH` or `POP` operation.

The stack operates as a circular buffer if the `STVREN` bit is programmed to '0' (Configuration Words). This means that after the stack has been PUSHed sixteen times, the seventeenth PUSH overwrites the value that was stored from the first PUSH. The eighteenth PUSH overwrites the second PUSH (and so on). The `STKOVF` and `STKUNF` flag bits will be set on an Overflow/Underflow Reset, regardless of whether the Reset is enabled.

**Note:** There are no instructions/mnemonics called `PUSH` or `POP`. These are actions that occur from the execution of the `CALL`, `CALLW`, `RETURN`, `RETLW` and `RETFIE` instructions or the vectoring to an interrupt address.

### 3.5.1 ACCESSING THE STACK

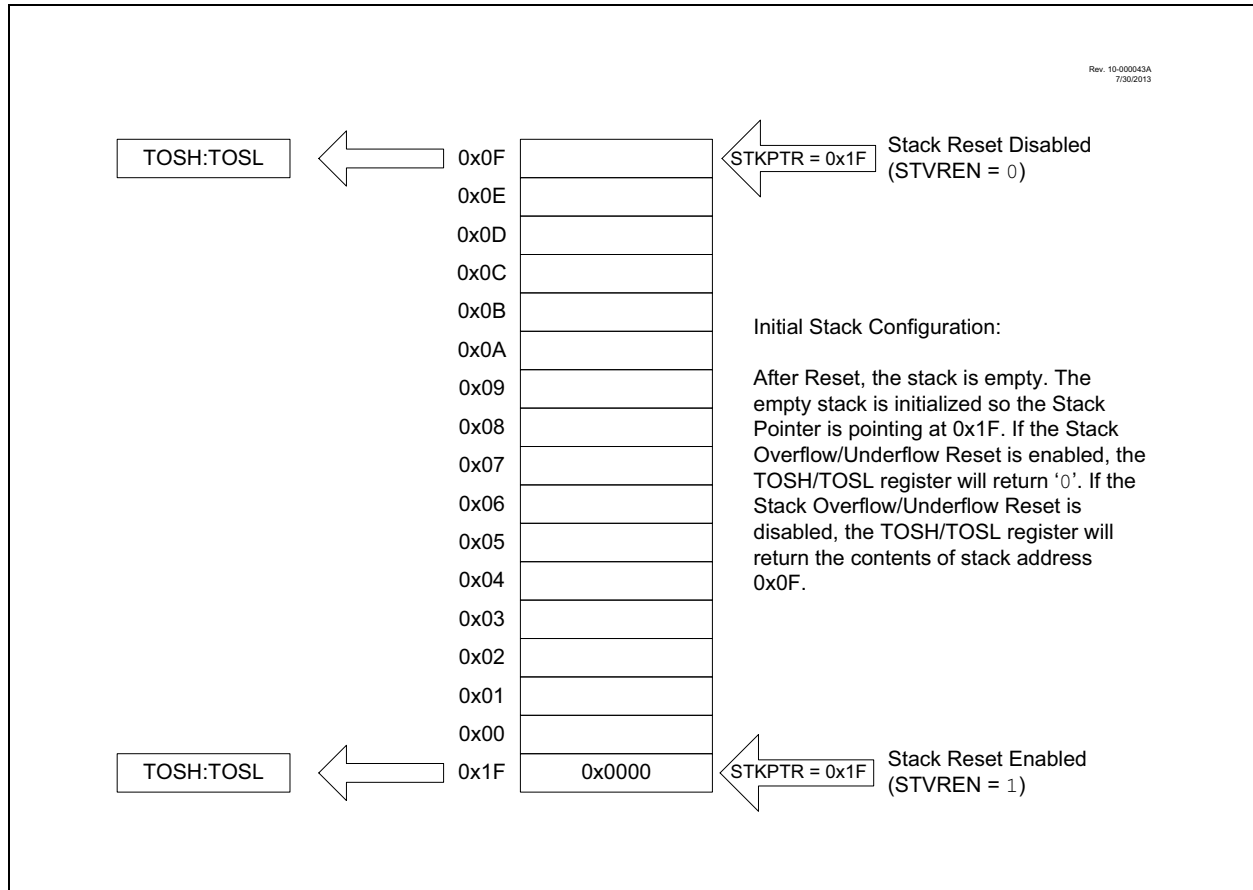
The stack is available through the `TOSH`, `TOSL` and `STKPTR` registers. `STKPTR` is the current value of the Stack Pointer. `TOSH:TOSL` register pair points to the TOP of the stack. Both registers are read/writable. `TOS` is split into `TOSH` and `TOSL` due to the 15-bit size of the PC. To access the stack, adjust the value of `STKPTR`, which will position `TOSH:TOSL`, then read/write to `TOSH:TOSL`. `STKPTR` is five bits to allow detection of overflow and underflow.

**Note:** Care should be taken when modifying the `STKPTR` while interrupts are enabled.

During normal program operation, `CALL`, `CALLW` and Interrupts will increment `STKPTR` while `RETLW`, `RETURN`, and `RETFIE` will decrement `STKPTR`. At any time, `STKPTR` can be inspected to see how much stack is left. The `STKPTR` always points at the currently used place on the stack. Therefore, a `CALL` or `CALLW` will increment the `STKPTR` and then write the PC, and a return will unload the PC and then decrement the `STKPTR`.

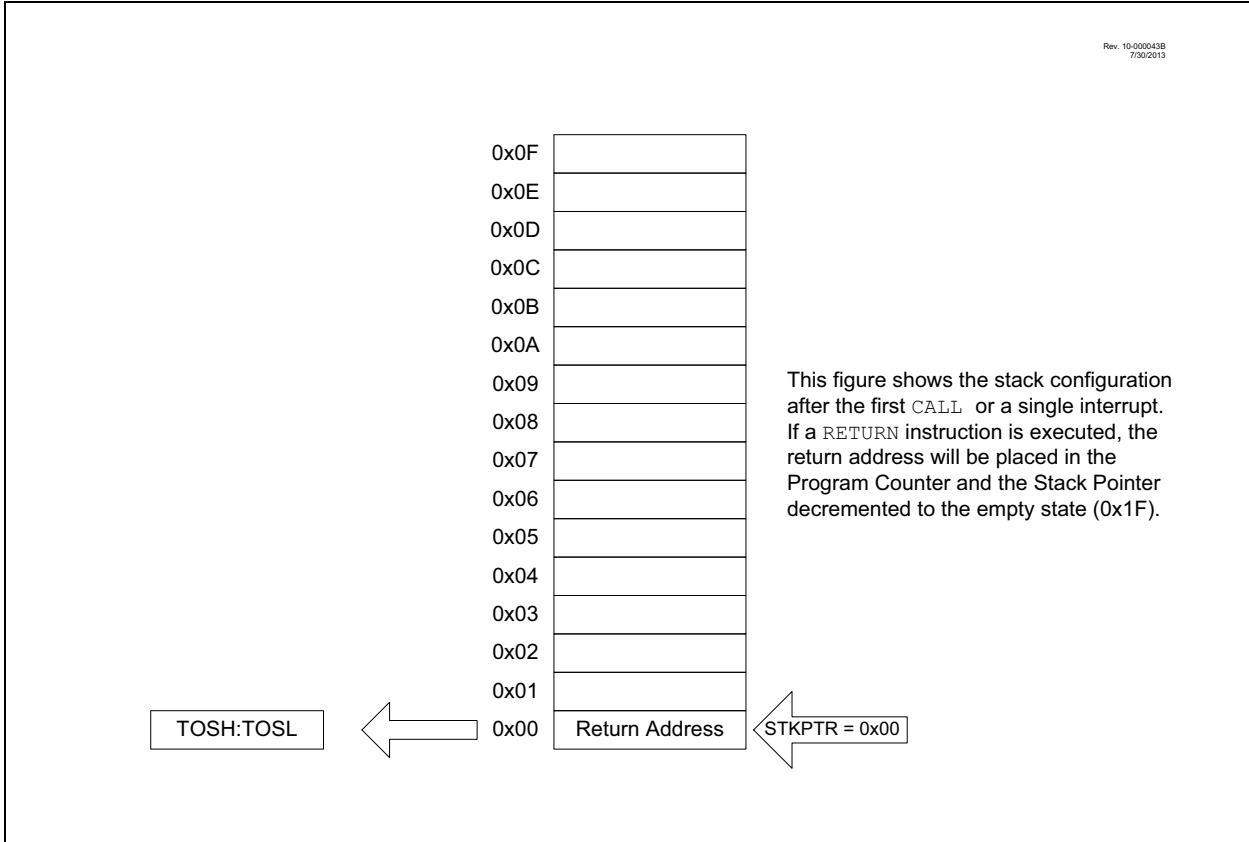
Reference [Figure 3-4](#) through [Figure 3-7](#) for examples of accessing the stack.

**FIGURE 3-4: ACCESSING THE STACK EXAMPLE 1**

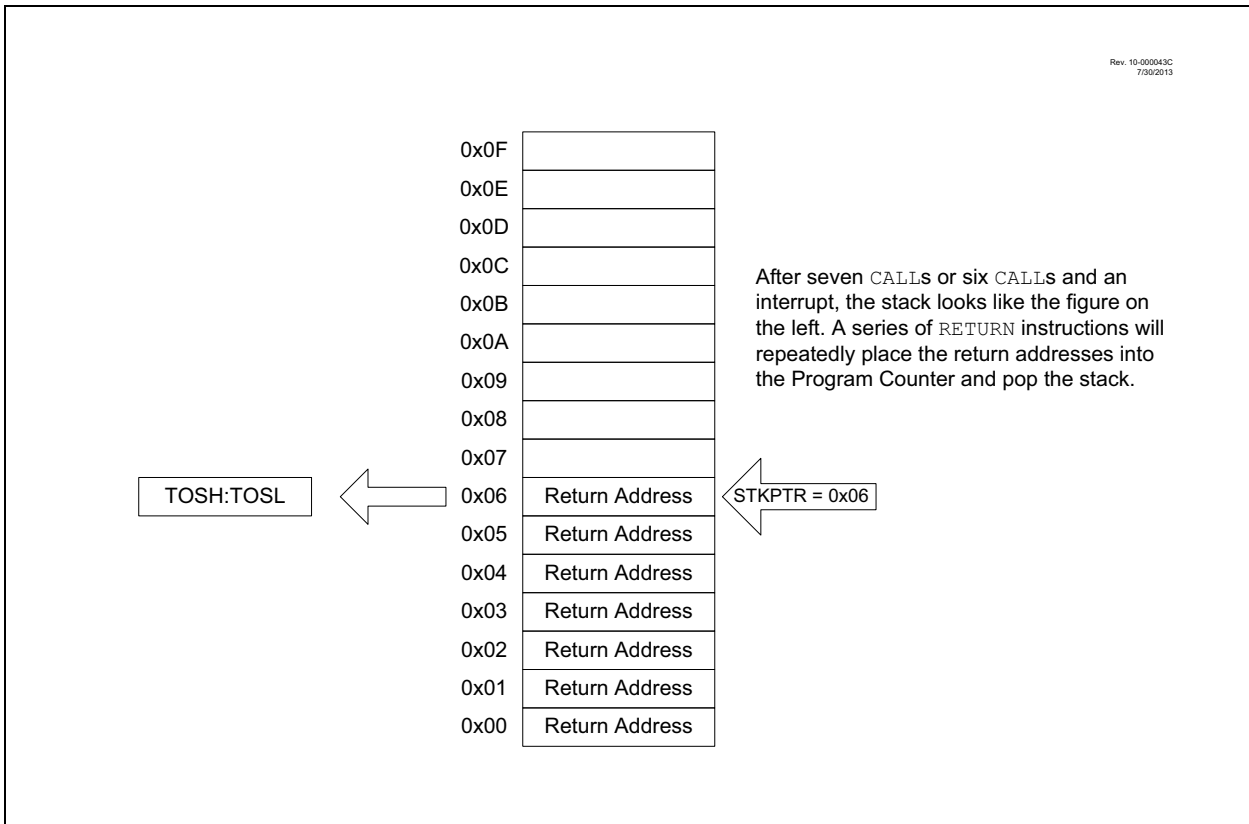




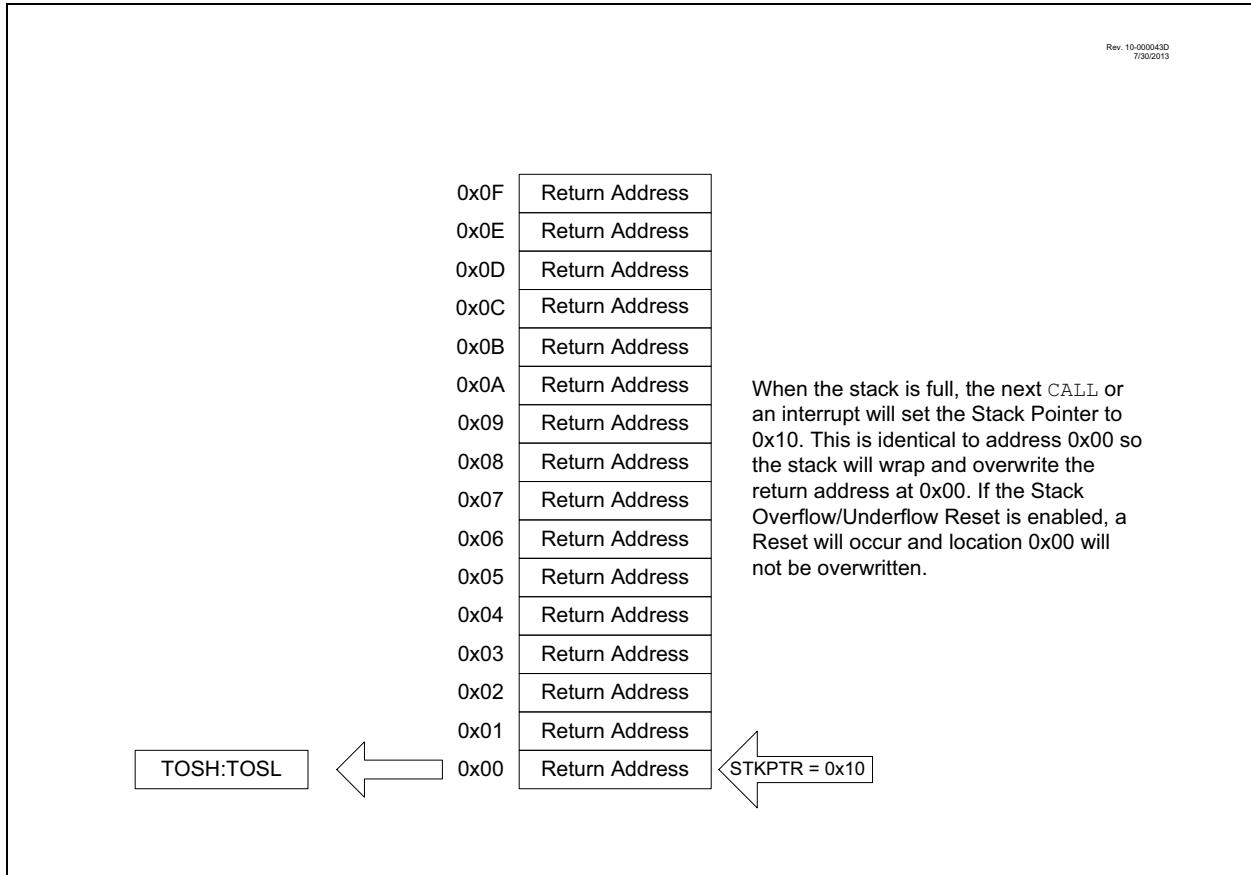
**FIGURE 3-5: ACCESSING THE STACK EXAMPLE 2**



**FIGURE 3-6: ACCESSING THE STACK EXAMPLE 3**



**FIGURE 3-7: ACCESSING THE STACK EXAMPLE 4**



### 3.5.2 OVERFLOW/UNDERFLOW RESET

If the *STVREN* bit in Configuration Words is programmed to '1', the device will be reset if the stack is *PUSHed* beyond the sixteenth level or *POPed* beyond the first level, setting the appropriate bits (*STKOVF* or *STKUNF*, respectively) in the *PCON* register.

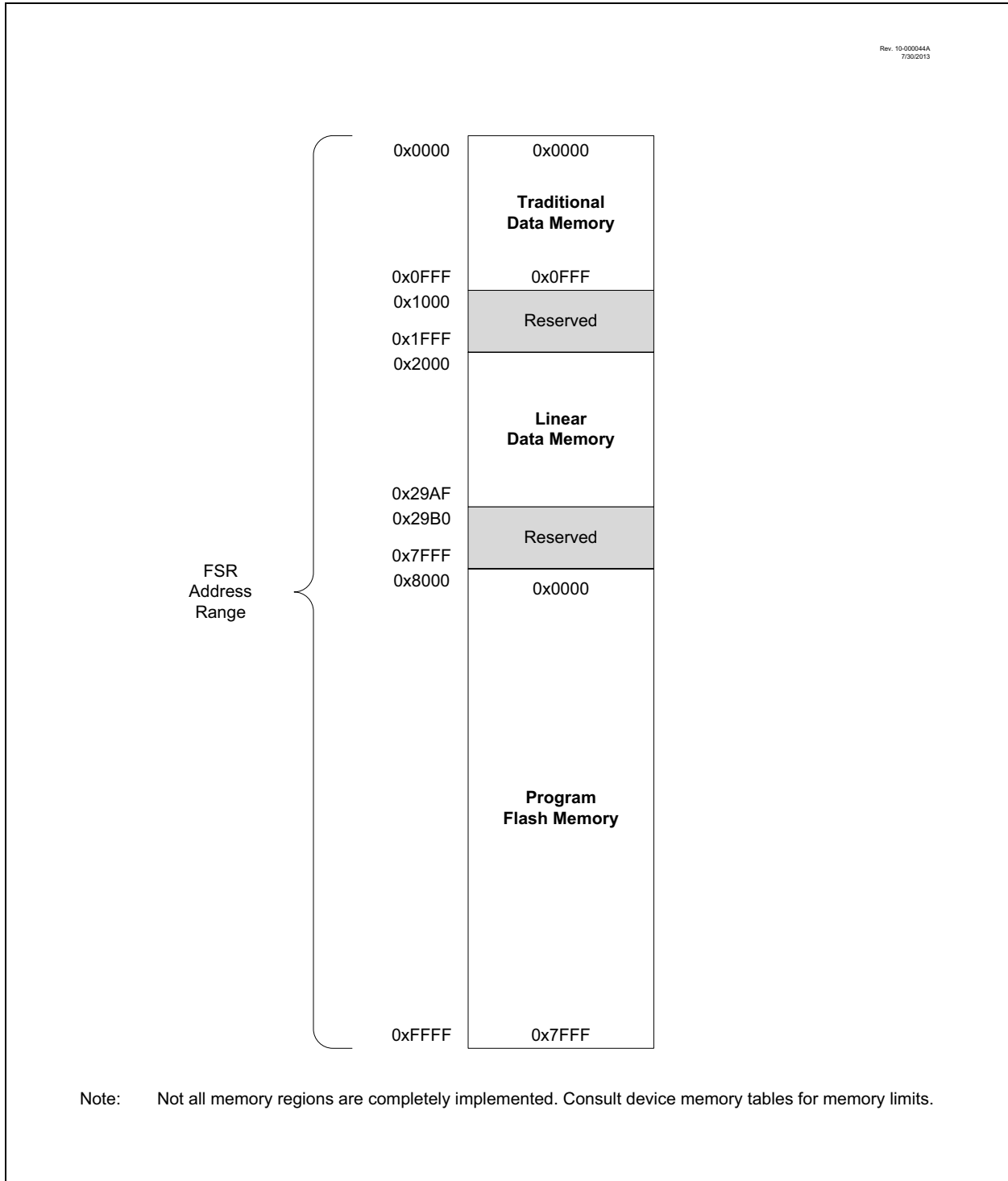
### 3.6 Indirect Addressing

The *INDFn* registers are not physical registers. Any instruction that accesses an *INDFn* register actually accesses the register at the address specified by the File Select Registers (*FSRs*). If the *FSRn* address specifies one of the two *INDFn* registers, the read will return '0' and the write will not occur (though Status bits may be affected). The *FSRn* register value is created by the pair, *FSRnH* and *FSRnL*.

The *FSRn* registers form a 16-bit address that allows an addressing space with 65536 locations. These locations are divided into three memory regions:

- Traditional Data Memory
- Linear Data Memory
- Program Flash Memory

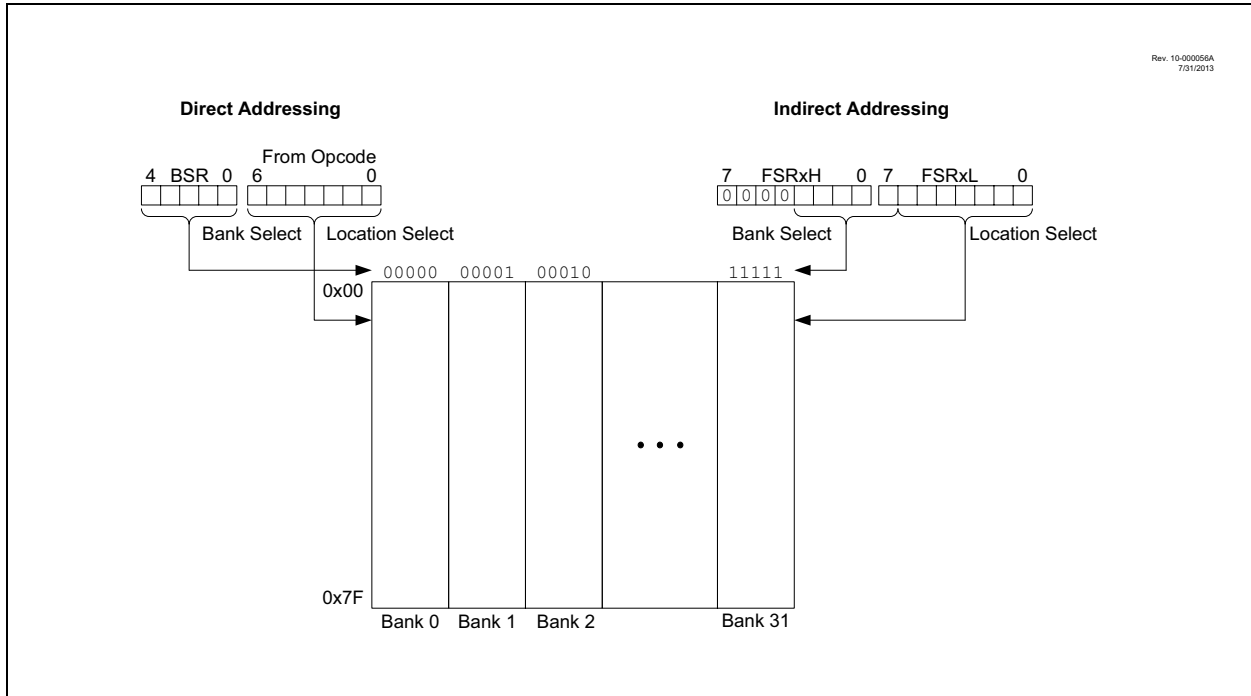
**FIGURE 3-8: INDIRECT ADDRESSING**



## 3.6.1 TRADITIONAL DATA MEMORY

The traditional data memory is a region from FSRn address, 0x000, to FSRn address, 0xFFF. The addresses correspond to the absolute addresses of all SFRs, GPRs and common registers.

**FIGURE 3-9: TRADITIONAL DATA MEMORY MAP**



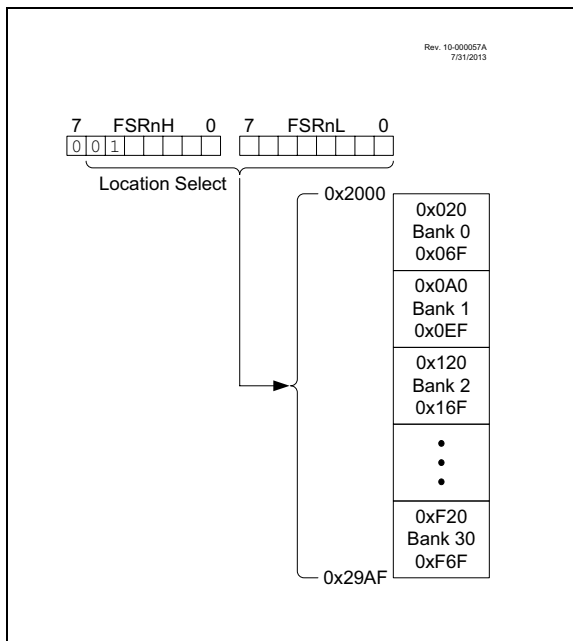
## 3.6.2 LINEAR DATA MEMORY

The linear data memory is the region from FSRn address, 0x2000, to FSRn address, 0x29AF. This region is a virtual region that points back to the 80-byte blocks of GPR memory in all the banks.

Unimplemented memory reads as 0x00. Use of the linear data memory region allows buffers to be larger than 80 bytes because incrementing the FSRn beyond one bank will go directly to the GPR memory of the next bank.

The 16 bytes of common memory are not included in the linear data memory region.

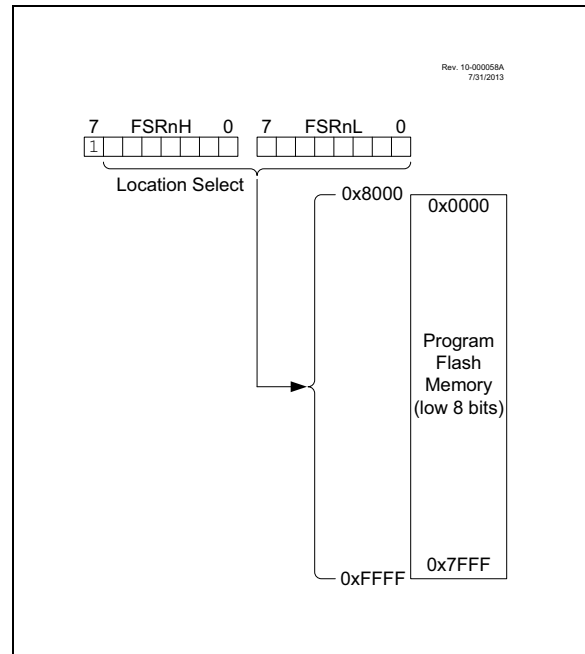
**FIGURE 3-10: LINEAR DATA MEMORY MAP**



## 3.6.3 PROGRAM FLASH MEMORY

To make constant data access easier, the entire Program Flash Memory is mapped to the upper half of the FSRn address space. When the MSB of FSRnH is set, the lower 15 bits are the address in program memory which will be accessed through INDFn. Only the lower eight bits of each memory location are accessible via INDFn. Writing to the Program Flash Memory cannot be accomplished via the FSRn/INDFn interface. All instructions that access Program Flash Memory via the FSRn/INDFn interface will require one additional instruction cycle to complete.

**FIGURE 3-11: PROGRAM FLASH MEMORY MAP**



## 4.0 DEVICE CONFIGURATION

Device configuration consists of Configuration Words, code protection and Device ID.

### 4.1 Configuration Words

There are several Configuration Word bits that allow different oscillator and memory protection options. These are implemented as Configuration Word 1 at 8007h and Configuration Word 2 at 8008h.

**Note:** The  $\overline{\text{DEBUG}}$  bit in Configuration Words is managed automatically by device development tools, including debuggers and programmers. For normal device operation, this bit should be maintained as a '1'.

## 4.2 Register Definitions: Configuration Words

### REGISTER 4-1: CONFIG1: CONFIGURATION WORD 1

R/P-1	R/P-1	R/P-1	R/P-1	R/P-1	U-1
FCMEN	IESO	CLKOUTEN	BOREN<1:0>		—
bit 13					bit 8

R/P-1	R/P-1	R/P-1	R/P-1	R/P-1	R/P-1	R/P-1	R/P-1
CP <sup>(1)</sup>	MCLRE	PWRTE	WDTE<1:0>		FOSC<2:0>		
bit 7							bit 0

#### Legend:

R = Readable bit	P = Programmable bit	U = Unimplemented bit, read as '1'
'0' = Bit is cleared	'1' = Bit is set	-n = Value when blank or after Bulk Erase

- bit 13     **FCMEN:** Fail-Safe Clock Monitor Enable bit  
 1 = On   Fail-Safe Clock Monitor and Internal/External Switchover mode are both enabled  
 0 = Off   Fail-Safe Clock Monitor is disabled
- bit 12     **IESO:** Internal External Switchover bit  
 1 = On   Internal/External Switchover mode is enabled  
 0 = Off   Internal/External Switchover mode is disabled
- bit 11     **CLKOUTEN:** Clock Out Enable bit  
If FOSC<2:0> Configuration bits are Set to LP, XT, HS modes:  
 This bit is ignored, CLKOUT function is disabled. Oscillator function on the CLKOUT pin.  
All other FOSC<2:0> modes:  
 1 = On   CLKOUT function is disabled. I/O function on the CLKOUT pin  
 0 = Off   CLKOUT function is enabled on the CLKOUT pin
- bit 10-9   **BOREN<1:0>:** Brown-out Reset Enable bits  
 11 = On   BOR is enabled  
 10 = NSLEEP BOR is enabled during operation and disabled in Sleep  
 01 = SBODEN BOR is controlled by the SBOREN bit of the BORCON register  
 00 = Off   BOR is disabled
- bit 8     **Unimplemented:** Read as '1'
- bit 7     **CP:** Code Protection bit<sup>(1)</sup>  
 1 = Off   Program memory code protection is disabled  
 0 = On    Program memory code protection is enabled
- bit 6     **MCLRE:** MCLR/VPP Pin Function Select bit  
If LVP bit = 1:  
 This bit is ignored.  
If LVP bit = 0:  
 1 = On   MCLR/VPP pin function is MCLR; weak pull-up is enabled  
 0 = Off   MCLR/VPP pin function is a digital input, MCLR is internally disabled; weak pull-up is under control of the WPUA3 bit
- bit 5     **PWRTE:** Power-up Timer Enable bit  
 1 = Off   PWRT is disabled  
 0 = On    PWRT is enabled

**Note 1:** The entire Flash program memory will be erased when the code protection is turned off during an erase. When a bulk erase program memory command is executed, the entire Program Flash Memory and configuration memory will be erased.

## REGISTER 4-1: CONFIG1: CONFIGURATION WORD 1 (CONTINUED)

- bit 4-3      **WDTE<1:0>**: Watchdog Timer Enable bit
- 11 = On      WDT is enabled
  - 10 = NSLEEP    WDT is enabled while running and disabled in Sleep
  - 01 = SWDTEN    WDT is controlled by the SWDTEN bit in the WDTCON register
  - 00 = Off      WDT is disabled
- bit 2-0      **FOSC<2:0>**: Oscillator Selection bits
- 111 = ECH      External Clock, High-Power mode: CLKIN supplied to OSC1/CLKIN pin
  - 110 = ECM      External Clock, Medium Power mode: CLKIN supplied to OSC1/CLKIN pin
  - 101 = ECL      External Clock, Low-Power mode: CLKIN supplied to OSC1/CLKIN pin
  - 100 = INTOSC    Internal HFINTOSC: I/O function on CLKIN pin
  - 011 = EXTRC    External RC circuit connected to CLKIN pin
  - 010 = HS      High-speed crystal/resonator connected between OSC1 and OSC2 pins
  - 001 = XT      Crystal/resonator connected between OSC1 and OSC2 pins
  - 000 = LP      Low-power crystal connected between OSC1 and OSC2 pins

**Note 1:** The entire Flash program memory will be erased when the code protection is turned off during an erase. When a bulk erase program memory command is executed, the entire Program Flash Memory and configuration memory will be erased.



## REGISTER 4-2: CONFIG2: CONFIGURATION WORD 2

R/P-1	R/P-1	R/P-1	R/P-1	R/P-1	R/P-1
LVP <sup>(1)</sup>	$\overline{\text{DEBUG}}$ <sup>(2)</sup>	$\overline{\text{LPBOR}}$	BORV <sup>(3)</sup>	STVREN	PLLEN
bit 13					bit 8

R/P-1	U-1	U-1	U-1	U-1	R/P-1	R/P-1	R/P-1
$\overline{\text{ZCD}}$	—	—	—	—	PPS1WAY	WRT<1:0>	
bit 7							bit 0

### Legend:

R = Readable bit                      P = Programmable bit                      U = Unimplemented bit, read as '1'  
 '0' = Bit is cleared                      '1' = Bit is set                                      -n = Value when blank or after Bulk Erase

- bit 13      **LVP:** Low-Voltage Programming Enable bit<sup>(1)</sup>  
 1 = On    Low-Voltage Programming is enabled  
 0 = Off    High-voltage on  $\overline{\text{MCLR}}$  must be used for programming
- bit 12      **DEBUG:** In-Circuit Debugger Mode bit<sup>(2)</sup>  
 1 = Off    In-Circuit Debugger is disabled, ICSPCLK and ICSPDAT are general purpose I/O pins  
 0 = On    In-Circuit Debugger is enabled, ICSPCLK and ICSPDAT are dedicated to the debugger
- bit 11      **LPBOR:** Low-Power BOR Enable bit  
 1 = Off    Low-Power Brown-out Reset is disabled  
 0 = On    Low-Power Brown-out Reset is enabled
- bit 10      **BORV:** Brown-out Reset Voltage Selection bit<sup>(3)</sup>  
 1 = LO    Brown-out Reset Voltage ( $\overline{\text{VBOR}}$ ), low trip point is selected  
 0 = HI    Brown-out Reset Voltage ( $\overline{\text{VBOR}}$ ), high trip point is selected
- bit 9        **STVREN:** Stack Overflow/Underflow Reset Enable bit  
 1 = On    Stack Overflow or Underflow will cause a Reset  
 0 = Off    Stack Overflow or Underflow will not cause a Reset
- bit 8        **PLLEN:** PLL Enable bit  
 1 = On    4xPLL is enabled  
 0 = Off    4xPLL is disabled
- bit 7        **ZCD:** ZCD Enable bit  
 1 = Off    ZCD is disabled, ZCD can be enabled by setting the ZCDSEN bit of ZCDCON  
 0 = On    ZCD is always enabled
- bit 6-3      **Unimplemented:** Read as '1'
- bit 2        **PPS1WAY:** PPSLOCK Bit One-Way Set Enable bit  
 1 = On    The PPSLOCK bit can only be set once after an unlocking sequence is executed; once PPSLOCK is set, all future changes to PPS registers are prevented  
 0 = Off    The PPSLOCK bit can be set and cleared as needed (provided an unlocking sequence is executed)

- Note 1:** The LVP bit cannot be programmed to '0' when Programming mode is entered via LVP.  
**2:** The  $\overline{\text{DEBUG}}$  bit in the Configuration Words is managed automatically by device development tools, including debuggers and programmers. For normal device operation, this bit should be maintained as a '1'.  
**3:** See  $\overline{\text{VBOR}}$  parameter for specific trip point voltages.

## REGISTER 4-2: CONFIG2: CONFIGURATION WORD 2 (CONTINUED)

bit 1-0 **WRT<1:0>**: Flash Memory Self-Write Protection bits

4 kW Flash Memory (PIC16(L)F1764/8):

11 = Off Write protection is off

10 = Boot 0000h to 01FFh are write-protected, 0200h to 0FFFh may be modified by PMCON control

01 = Half 0000h to 07FFh are write-protected, 0800h to 0FFFh may be modified by PMCON control

00 = All 0000h to 0FFFh are write-protected, no addresses may be modified by PMCON control

8 kW Flash Memory (PIC16(L)F1765/9):

11 = Off Write protection is off

10 = Boot 0000h to 01FFh are write-protected, 0200h to 1FFFh may be modified by PMCON control

01 = Half 0000h to 0FFFh are write-protected, 1000h to 1FFFh may be modified by PMCON control

00 = All 0000h to 1FFFh are write-protected, no addresses may be modified by PMCON control

- Note 1:** The LVP bit cannot be programmed to '0' when Programming mode is entered via LVP.
- 2:** The  $\overline{\text{DEBUG}}$  bit in the Configuration Words is managed automatically by device development tools, including debuggers and programmers. For normal device operation, this bit should be maintained as a '1'.
- 3:** See [VBOR](#) parameter for specific trip point voltages.

## 4.3 Code Protection

Code protection allows the device to be protected from unauthorized access. Program memory protection is controlled independently. Internal access to the program memory is unaffected by any code protection setting.

### 4.3.1 PROGRAM MEMORY PROTECTION

The entire program memory space is protected from external reads and writes by the  $\overline{CP}$  bit in the Configuration Words. When  $\overline{CP} = 0$ , external reads and writes of program memory are inhibited and a read will return all '0's. The CPU can continue to read program memory, regardless of the protection bit settings. Writing the program memory is dependent upon the write protection setting. See [Section 4.4 "Write Protection"](#) for more information.

## 4.4 Write Protection

Write protection allows the device to be protected from unintended self-writes. Applications, such as boot loader software, can be protected while allowing other regions of the program memory to be modified.

The  $WRT<1:0>$  bits in the Configuration Words define the size of the program memory block that is protected.

## 4.5 User ID

Four memory locations (8000h-8003h) are designated as ID locations where the user can store checksum or other code identification numbers. These locations are readable and writable during normal execution. See [Section 10.4 "User ID, Device ID and Configuration Word Access"](#) for more information on accessing these memory locations. For more information on checksum calculation, see the *"PIC16(L)F170X Memory Programming Specification"* (DS40001683).

## 4.6 Device ID and Revision ID

The 14-bit Device ID word is located at 8006h and the 14-bit Revision ID is located at 8005h. These locations are read-only and cannot be erased or modified. See **Section 10.4 “User ID, Device ID and Configuration Word Access”** for more information on accessing these memory locations.

Development tools, such as device programmers and debuggers, may be used to read the Device ID and Revision ID.

## 4.7 Register Definitions: Device and Revision

**REGISTER 4-3: DEVID: DEVICE ID REGISTER**

R	R	R	R	R	R
DEV<13:8>					
bit 13			bit 8		

R	R	R	R	R	R	R	R
DEV<7:0>							
bit 7				bit 0			

**Legend:**

R = Readable bit                      '1' = Bit is set                      '0' = Bit is cleared

bit 13-0                      **DEV<13:0>**: Device ID bits

Device	DEVID<13:0> Values
PIC16F1764	11 0000 1000 0000 (3080h)
PIC16F1765	11 0000 1000 0001 (3081h)
PIC16F1768	11 0000 1000 0100 (3084h)
PIC16F1769	11 0000 1000 0101 (3085h)
PIC16LF1764	11 0000 1000 0010 (3082h)
PIC16LF1765	11 0000 1000 0011 (3083h)
PIC16LF1768	11 0000 1000 0110 (3086h)
PIC16LF1769	11 0000 1000 0111 (3087h)

## REGISTER 4-4: REVID: REVISION ID REGISTER

R	R	R	R	R	R
REV<13:8>					
bit 13					bit 8

R	R	R	R	R	R	R	R
REV<7:0>							
bit 7							bit 0

### Legend:

R = Readable bit

'1' = Bit is set

'0' = Bit is cleared

bit 13-0      **REV<13:0>**: Revision ID bits

## 5.0 OSCILLATOR MODULE (WITH FAIL-SAFE CLOCK MONITOR)

### 5.1 Overview

The oscillator module has a wide variety of clock sources and selection features that allow it to be used in a wide range of applications while maximizing performance and minimizing power consumption. [Figure 5-1](#) illustrates a block diagram of the oscillator module.

Clock sources can be supplied from external oscillators, quartz crystal resonators, ceramic resonators and Resistor-Capacitor (RC) circuits. In addition, the system clock source can be supplied from one of two internal oscillators and PLL circuits, with a choice of speeds selectable via software. Additional clock features include:

- Selectable system clock source between external or internal sources via software.
- Two-Speed Start-up mode, which minimizes latency between external oscillator start-up and code execution.
- Fail-Safe Clock Monitor (FSCM) designed to detect a failure of the external clock source (LP, XT, HS, ECH, ECM, ECL or EXTRC modes) and switch automatically to the internal oscillator.
- Oscillator Start-up Timer (OST) ensures stability of crystal oscillator sources.

The oscillator module can be configured in one of the following clock modes.

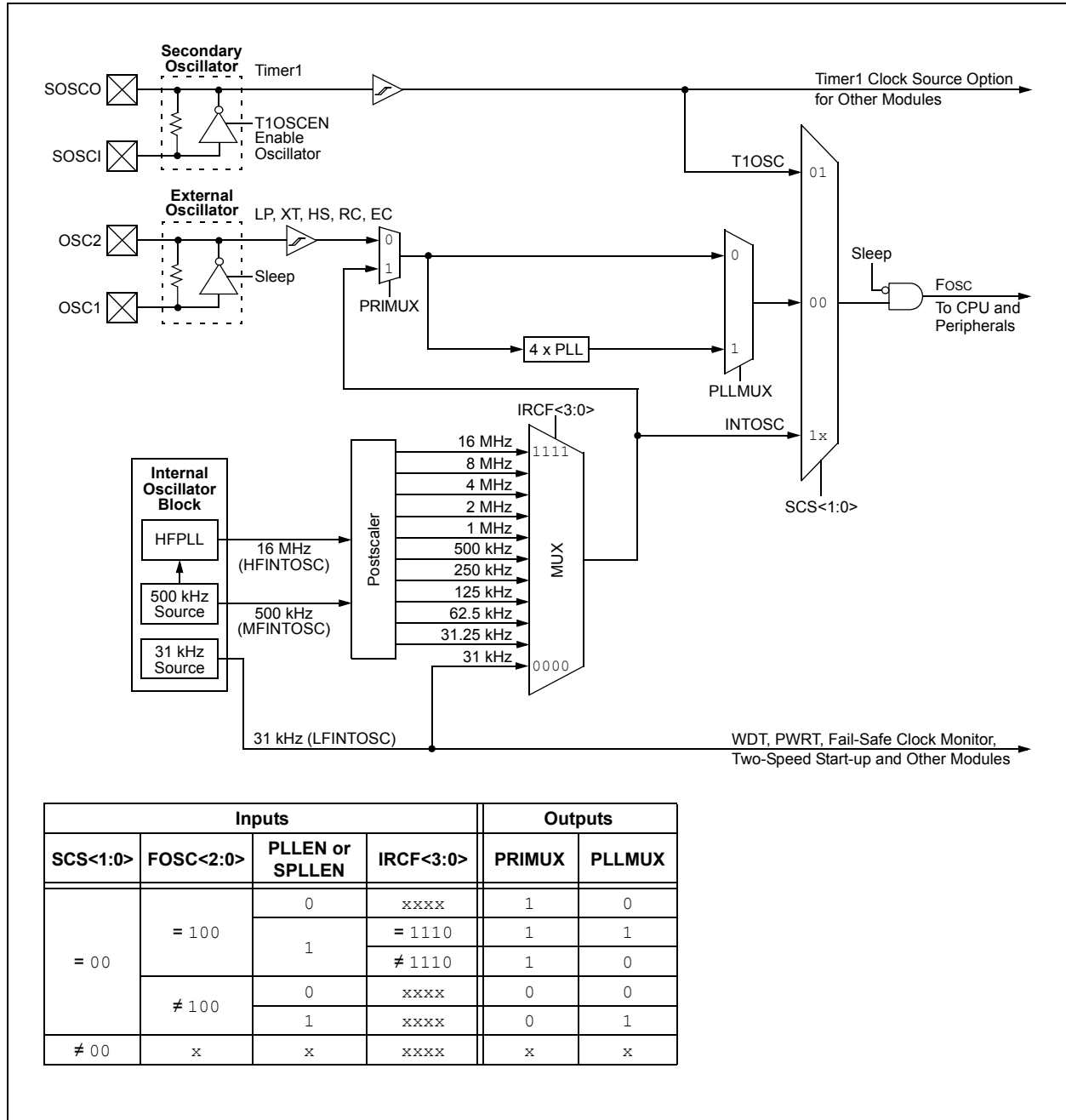
1. ECL – External Clock Low-Power mode (0 MHz to 0.5 MHz).
2. ECM – External Clock Medium Power mode (0.5 MHz to 4 MHz).
3. ECH – External Clock High-Power mode (4 MHz to 32 MHz).
4. LP – 32 kHz Low-Power Crystal mode.
5. XT – Medium Gain Crystal or Ceramic Resonator Oscillator mode (up to 4 MHz).
6. HS – High Gain Crystal or Ceramic Resonator mode (4 MHz to 20 MHz).
7. EXTRC – External Resistor-Capacitor.
8. INTOSC – Internal Oscillator (31 kHz to 32 MHz).

Clock source modes are selected by the FOSC<2:0> bits in the Configuration Words. The FOSC<sub>x</sub> bits determine the type of oscillator that will be used when the device is first powered.

The ECH, ECM and ECL Clock modes rely on an external logic level signal as the device clock source. The LP, XT and HS Clock modes require an external crystal or resonator to be connected to the device. Each mode is optimized for a different frequency range. The EXTRC Clock mode requires an external resistor and capacitor to set the oscillator frequency.

The Internal Oscillator Block (INTOSC) produces low, medium and high-frequency clock sources, designated LFINTOSC, MFINTOSC and HFINTOSC (see Internal Oscillator Block, [Figure 5-1](#)). A wide selection of device clock frequencies may be derived from these three clock sources.

**FIGURE 5-1: SIMPLIFIED PIC® MCU CLOCK SOURCE BLOCK DIAGRAM**



Inputs				Outputs	
SCS<1:0>	FOSC<2:0>	PLLEN or SPLEN	IRCF<3:0>	PRIMUMUX	PLLMUX
= 00	= 100	0	xxxx	1	0
		1	= 1110	1	1
	≠ 100	0	≠ 1110	1	0
		1	xxxx	0	0
≠ 00	x	x	xxxx	x	x

## 5.2 Clock Source Types

Clock sources can be classified as external or internal.

External clock sources rely on external circuitry for the clock source to function. Examples are: oscillator modules (ECH, ECM, ECL modes), quartz crystal resonators or ceramic resonators (LP, XT and HS modes) and Resistor-Capacitor (EXTRC) mode circuits.

Internal clock sources are contained within the oscillator module. The Internal Oscillator Block has two internal oscillators and a dedicated Phase-Locked Loop (HFPLL) that are used to generate three internal system clock sources: the 16 MHz High-Frequency Internal Oscillator (HFINTOSC), 500 kHz Medium Frequency Internal Oscillator (MFINTOSC) and the 31 kHz Low-Frequency Internal Oscillator (LFINTOSC).

The system clock can be selected between external or internal clock sources via the System Clock Select (SCSx) bits in the OSCCON register. See [Section 5.3 “Clock Switching”](#) for additional information.

### 5.2.1 EXTERNAL CLOCK SOURCES

An external clock source can be used as the device system clock by performing one of the following actions:

- Program the FOSC<2:0> bits in the Configuration Words to select an external clock source that will be used as the default system clock upon a device Reset.
- Write the SCS<1:0> bits in the OSCCON register to switch the system clock source to:
  - Secondary oscillator during run time, or
  - An external clock source determined by the value of the FOSCx bits.

See [Section 5.3 “Clock Switching”](#) for more information.

#### 5.2.1.1 EC Mode

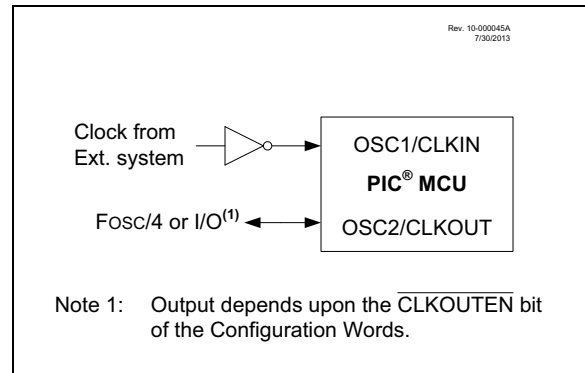
The External Clock (EC) mode allows an externally generated logic level signal to be the system clock source. When operating in this mode, an external clock source is connected to the OSC1 input. OSC2/CLKOUT is available for general purpose I/O or CLKOUT. [Figure 5-2](#) shows the pin connections for EC mode.

EC mode has three power modes to select from through the Configuration Words:

- ECH – High power, 4-32 MHz
- ECM – Medium power, 0.5-4 MHz
- ECL – Low power, 0-0.5 MHz

The Oscillator Start-up Timer (OST) is disabled when EC mode is selected. Therefore, there is no delay in operation after a Power-on Reset (POR) or wake-up from Sleep. Because the PIC® MCU design is fully static, stopping the external clock input will have the effect of halting the device while leaving all data intact. Upon restarting the external clock, the device will resume operation as if no time had elapsed.

**FIGURE 5-2: EXTERNAL CLOCK (EC) MODE OPERATION**



#### 5.2.1.2 LP, XT, HS Modes

The LP, XT and HS modes support the use of quartz crystal resonators or ceramic resonators connected to OSC1 and OSC2 ([Figure 5-3](#)). The three modes select a low, medium or high gain setting of the internal inverter-amplifier to support various resonator types and speed.

**LP** Oscillator mode selects the lowest gain setting of the internal inverter-amplifier. LP mode current consumption is the least of the three modes. This mode is designed to drive only 32.768 kHz tuning-fork type crystals (watch crystals).

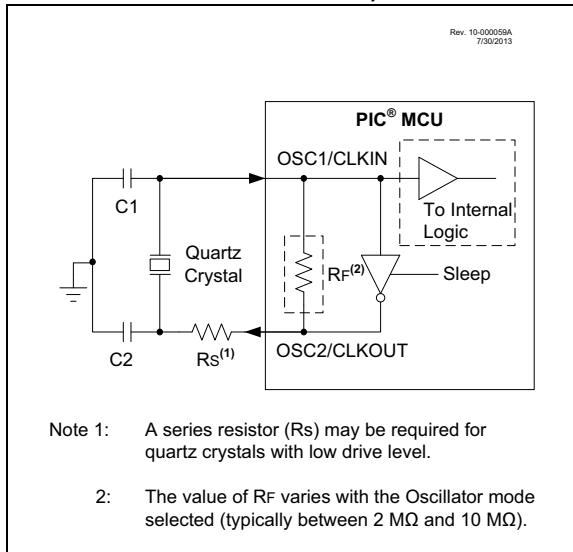
**XT** Oscillator mode selects the intermediate gain setting of the internal inverter-amplifier. XT mode current consumption is the medium of the three modes. This mode is best suited to drive resonators with a medium drive level specification.

**HS** Oscillator mode selects the highest gain setting of the internal inverter-amplifier. HS mode current consumption is the highest of the three modes. This mode is best suited for resonators that require a high drive setting.

[Figure 5-3](#) and [Figure 5-4](#) show typical circuits for quartz crystal and ceramic resonators, respectively.



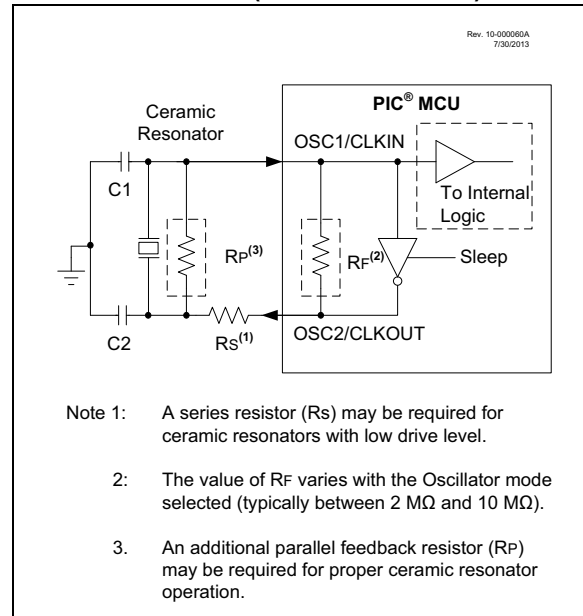
**FIGURE 5-3: QUARTZ CRYSTAL OPERATION (LP, XT OR HS MODE)**



**Note 1:** Quartz crystal characteristics vary according to type, package and manufacturer. The user should consult the manufacturer data sheets for specifications and recommended application.

- 2:** Always verify oscillator performance over the  $V_{DD}$  and temperature range that is expected for the application.
- 3:** For oscillator design assistance, reference the following Microchip Application Notes:
  - AN826, “Crystal Oscillator Basics and Crystal Selection for *rPIC*<sup>®</sup> and *PIC*<sup>®</sup> Devices” (DS00826)
  - AN849, “Basic *PIC*<sup>®</sup> Oscillator Design” (DS00849)
  - AN943, “Practical *PIC*<sup>®</sup> Oscillator Analysis and Design” (DS00943)
  - AN949, “Making Your Oscillator Work” (DS00949)

**FIGURE 5-4: CERAMIC RESONATOR OPERATION (XT OR HS MODE)**



### 5.2.1.3 Oscillator Start-up Timer (OST)

If the oscillator module is configured for LP, XT or HS modes, the Oscillator Start-up Timer (OST) counts 1024 oscillations from OSC1. This occurs following a Power-on Reset (POR) and when the Power-up Timer (PWRT) has expired (if configured), or a wake-up from Sleep. During this time, the Program Counter does not increment and program execution is suspended, unless either FSCM or Two-Speed Start-up is enabled. In this case, code will continue to execute at the selected INTOSC frequency while the OST is counting. The OST ensures that the oscillator circuit, using a quartz crystal resonator or ceramic resonator, has started and is providing a stable system clock to the oscillator module.

In order to minimize latency between external oscillator start-up and code execution, the Two-Speed Clock Start-up mode can be selected (see [Section 5.4 “Two-Speed Clock Start-up Mode”](#)).

## 5.2.1.4 4x PLL

The oscillator module contains a 4x PLL that can be used with both external and internal clock sources to provide a system clock source. The input frequency for the 4x PLL must fall within specifications. See the PLL Clock Timing Specifications in [Table 36-9](#).

The 4x PLL may be enabled for use by one of two methods:

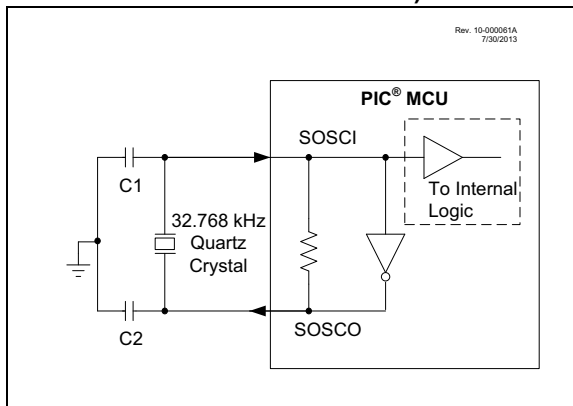
1. Program the PLEN bit in the Configuration Words to a '1'.
2. Write the SPLLEN bit in the OSCCON register to a '1'. If the PLEN bit in the Configuration Words is programmed to a '1', then the value of SPLLEN is ignored.

## 5.2.1.5 Secondary Oscillator

The secondary oscillator is a separate crystal oscillator that is associated with the Timer1 peripheral. It is optimized for timekeeping operations with a 32.768 kHz crystal connected between the SOSCO and SOSCI device pins.

The secondary oscillator can be used as an alternate system clock source and can be selected during run time using clock switching. Refer to [Section 5.3 "Clock Switching"](#) for more information.

**FIGURE 5-5: QUARTZ CRYSTAL OPERATION (SECONDARY OSCILLATOR)**



**Note 1:** Quartz crystal characteristics vary according to type, package and manufacturer. The user should consult the manufacturer data sheets for specifications and recommended application.

**2:** Always verify oscillator performance over the VDD and temperature range that is expected for the application.

**3:** For oscillator design assistance, reference the following Microchip Application Notes:

- AN826, "Crystal Oscillator Basics and Crystal Selection for rPIC<sup>®</sup> and PIC<sup>®</sup> Devices" (DS00826)
- AN849, "Basic PIC<sup>®</sup> Oscillator Design" (DS00849)
- AN943, "Practical PIC<sup>®</sup> Oscillator Analysis and Design" (DS00943)
- AN949, "Making Your Oscillator Work" (DS00949)
- TB097, "Interfacing a Micro Crystal MS1V-T1K 32.768 kHz Tuning Fork Crystal to a PIC16F690/SS" (DS91097)
- AN1288, "Design Practices for Low-Power External Oscillators" (DS01288)

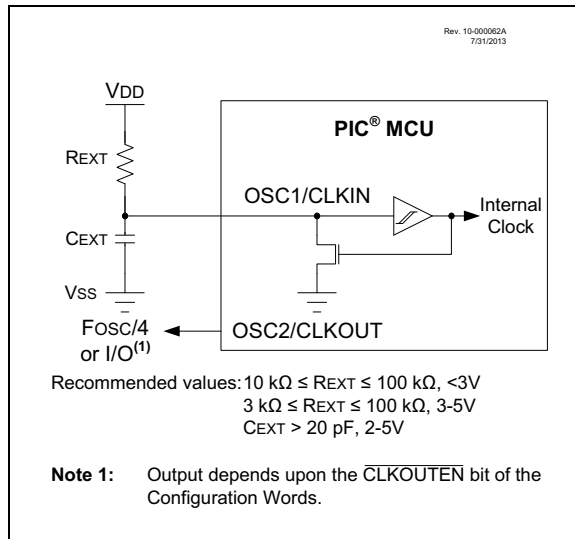
## 5.2.1.6 External RC Mode

The external Resistor-Capacitor (EXTRC) mode supports the use of an external RC circuit. This allows the designer maximum flexibility in frequency choice while keeping costs to a minimum when clock accuracy is not required.

The RC circuit connects to OSC1. OSC2/CLKOUT is available for general purpose I/O or CLKOUT. The function of the OSC2/CLKOUT pin is determined by the CLKOUTEN bit in the Configuration Words.

Figure 5-6 shows the external RC mode connections.

**FIGURE 5-6: EXTERNAL RC MODES**



The RC oscillator frequency is a function of the supply voltage, the Resistor ( $R_{EXT}$ ) and Capacitor ( $C_{EXT}$ ) values, and the operating temperature. Other factors affecting the oscillator frequency are:

- Threshold voltage variation
- Component tolerances
- Packaging variations in capacitance

The user also needs to take into account variation due to tolerance of external RC components used.

## 5.2.2 INTERNAL CLOCK SOURCES

The device may be configured to use the Internal Oscillator Block as the system clock by performing one of the following actions:

- Program the FOSC<2:0> bits in the Configuration Words to select the INTOSC clock source, which will be used as the default system clock upon a device Reset.
- Write the SCS<1:0> bits in the OSCCON register to switch the system clock source to the internal oscillator during run time. See [Section 5.3 "Clock Switching"](#) for more information.

In INTOSC mode, OSC1/CLKIN is available for general purpose I/O. OSC2/CLKOUT is available for general purpose I/O or CLKOUT.

The function of the OSC2/CLKOUT pin is determined by the CLKOUTEN bit in the Configuration Words.

The Internal Oscillator Block has two independent oscillators and a dedicated Phase-Locked Loop (HFPLL) that can produce one of three internal system clock sources.

1. The **HFINTOSC** (High-Frequency Internal Oscillator) is factory calibrated and operates at 16 MHz. The HFINTOSC source is generated from the 500 kHz MFINTOSC source and the dedicated Phase-Locked Loop, HFPLL. The frequency of the HFINTOSC can be user-adjusted via software using the OSCTUNE register ([Register 5-3](#)).
2. The **MFINTOSC** (Medium Frequency Internal Oscillator) is factory calibrated and operates at 500 kHz. The frequency of the MFINTOSC can be user-adjusted via software using the OSCTUNE register ([Register 5-3](#)).
3. The **LFINTOSC** (Low-Frequency Internal Oscillator) is uncalibrated and operates at 31 kHz.

## 5.2.2.1 HFINTOSC

The High-Frequency Internal Oscillator (HFINTOSC) is a factory calibrated, 16 MHz internal clock source. The frequency of the HFINTOSC can be altered via software using the OSCTUNE register ([Register 5-3](#)).

The output of the HFINTOSC connects to a postscaler and multiplexer (see [Figure 5-1](#)). One of multiple frequencies derived from the HFINTOSC can be selected via software using the IRCF<3:0> bits of the OSCCON register. See [Section 5.2.2.7 “Internal Oscillator Clock Switch Timing”](#) for more information.

The HFINTOSC is enabled by:

- Configuring the IRCF<3:0> bits of the OSCCON register for the desired HF frequency, and
- FOSC<2:0> = 100, or
- Setting the System Clock Source (SCS<1:0>) bits of the OSCCON register to '1x'

A fast start-up oscillator allows internal circuits to power up and stabilize before switching to HFINTOSC.

The High-Frequency Internal Oscillator Ready bit (HFIOFR) of the OSCSTAT register indicates when the HFINTOSC is running.

The High-Frequency Internal Oscillator Status Locked bit (HFIOFL) of the OSCSTAT register indicates when the HFINTOSC is running within 2% of its final value.

The High-Frequency Internal Oscillator Stable bit (HFIOFS) of the OSCSTAT register indicates when the HFINTOSC is running within 0.5% of its final value.

## 5.2.2.2 MFINTOSC

The Medium Frequency Internal Oscillator (MFINTOSC) is a factory calibrated 500 kHz internal clock source. The frequency of the MFINTOSC can be altered via software using the OSCTUNE register ([Register 5-3](#)).

The output of the MFINTOSC connects to a postscaler and multiplexer (see [Figure 5-1](#)). One of nine frequencies derived from the MFINTOSC can be selected via software using the IRCF<3:0> bits of the OSCCON register. See [Section 5.2.2.7 “Internal Oscillator Clock Switch Timing”](#) for more information.

The MFINTOSC is enabled by:

- Configuring the IRCF<3:0> bits of the OSCCON register for the desired HF frequency, and
- FOSC<2:0> = 100, or
- Setting the System Clock Source (SCS<1:0>) bits of the OSCCON register to '1x'

The Medium Frequency Internal Oscillator Ready bit (MFIOFR) of the OSCSTAT register indicates when the MFINTOSC is running.

## 5.2.2.3 Internal Oscillator Frequency Adjustment

The 500 kHz internal oscillator is factory calibrated. This internal oscillator can be adjusted in software by writing to the OSCTUNE register ([Register 5-3](#)). Since the HFINTOSC and MFINTOSC clock sources are derived from the 500 kHz internal oscillator, a change in the OSCTUNE register value will apply to both.

The default value of the OSCTUNE register is '0'. The value is a 6-bit two's complement number. A value of 1Fh will provide an adjustment to the maximum frequency. A value of 20h will provide an adjustment to the minimum frequency.

When the OSCTUNE register is modified, the oscillator frequency will begin shifting to the new frequency. Code execution continues during this shift. There is no indication that the shift has occurred.

OSCTUNE does not affect the LFINTOSC frequency. Operation of features that depend on the LFINTOSC clock source frequency, such as the Power-up Timer (PWRT), Watchdog Timer (WDT), Fail-Safe Clock Monitor (FSCM) and peripherals, are *not* affected by the change in frequency.

## 5.2.2.4 LFINTOSC

The Low-Frequency Internal Oscillator (LFINTOSC) is an uncalibrated 31 kHz internal clock source.

The output of the LFINTOSC connects to a multiplexer (see [Figure 5-1](#)). Select 31 kHz, via software, using the IRCF<3:0> bits of the OSCCON register. See [Section 5.2.2.7 “Internal Oscillator Clock Switch Timing”](#) for more information. The LFINTOSC is also the frequency for the Power-up Timer (PWRT), Watchdog Timer (WDT) and Fail-Safe Clock Monitor (FSCM).

The LFINTOSC is enabled by selecting 31 kHz (IRCF<3:0> (OSCCON<6:3>) = 000) as the system clock source (SCS<1:0> (OSCCON<1:0> = 1x) or when any of the following are enabled:

- Configuring the IRCF<3:0> bits of the OSCCON register for the desired LF frequency, and
- FOSC<2:0> = 100, or
- Setting the System Clock Source (SCS<1:0>) bits of the OSCCON register to '1x'

Peripherals that use the LFINTOSC are:

- Power-up Timer (PWRT)
- Watchdog Timer (WDT)
- Fail-Safe Clock Monitor (FSCM)

The Low-Frequency Internal Oscillator Ready bit (LFIOFR) of the OSCSTAT register indicates when the LFINTOSC is running.

## 5.2.2.5 Internal Oscillator Frequency Selection

The system clock speed can be selected via software using the Internal Oscillator Frequency Select bits  $IRCF<3:0>$  of the  $OSCCON$  register.

The postscaled output of the 16 MHz HFINTOSC, 500 kHz MFINTOSC, and 31 Hz LFINTOSC connect to a multiplexer (see [Figure 5-1](#)). The Internal Oscillator Frequency Select bits,  $IRCF<3:0>$  of the  $OSCCON$  register, select the frequency output of the internal oscillators. One of the following frequencies can be selected via software:

- 32 MHz (requires 4x PLL)
- 16 MHz
- 8 MHz
- 4 MHz
- 2 MHz
- 1 MHz
- 500 kHz (default after Reset)
- 250 kHz
- 125 kHz
- 62.5 kHz
- 31.25 kHz
- 31 kHz (LFINTOSC)

**Note:** Following any Reset, the  $IRCF<3:0>$  bits of the  $OSCCON$  register are set to '0111' and the frequency selection is set to 500 kHz. The user can modify the  $IRCFx$  bits to select a different frequency.

The  $IRCF<3:0>$  bits of the  $OSCCON$  register allow duplicate selections for some frequencies. These duplicate choices can offer system design trade-offs. Lower power consumption can be obtained when changing oscillator sources for a given frequency. Faster transition times can be obtained between frequency changes that use the same oscillator source.

## 5.2.2.6 32 MHz Internal Oscillator Frequency Selection

The Internal Oscillator Block can be used with the 4x PLL associated with the External Oscillator Block to produce a 32 MHz internal system clock source. The following settings are required to use the 32 MHz internal clock source:

- The  $FOSCx$  bits in the Configuration Words must be set to use the INTOSC source as the device system clock ( $FOSC<2:0> = 100$ ).
- The  $SCSx$  bits in the  $OSCCON$  register must be cleared to use the clock determined by  $FOSC<2:0>$  in the Configuration Words ( $SCS<1:0> = 00$ ).
- The  $IRCFx$  bits in the  $OSCCON$  register must be set to the 8 MHz HFINTOSC to use ( $IRCF<3:0> = 1110$ ).

- The  $SPLLEN$  bit in the  $OSCCON$  register must be set to enable the 4x PLL or the  $PLLEN$  bit of the Configuration Words must be programmed to a '1'.

**Note:** When using the  $PLLEN$  bit of the Configuration Words, the 4x PLL cannot be disabled by software and the  $SPLLEN$  option will not be available.

The 4x PLL is not available for use with the internal oscillator when the  $SCSx$  bits of the  $OSCCON$  register are set to '1x'. The  $SCSx$  bits must be set to '00' to use the 4x PLL with the internal oscillator.

## 5.2.2.7 Internal Oscillator Clock Switch Timing

When switching between the HFINTOSC, MFINTOSC and the LFINTOSC, the new oscillator may already be shut down to save power (see [Figure 5-7](#)). If this is the case, there is a delay after the  $IRCF<3:0>$  bits of the  $OSCCON$  register are modified before the frequency selection takes place. The  $OSCSTAT$  register will reflect the current active status of the HFINTOSC, MFINTOSC and LFINTOSC oscillators. The sequence of a frequency selection is as follows:

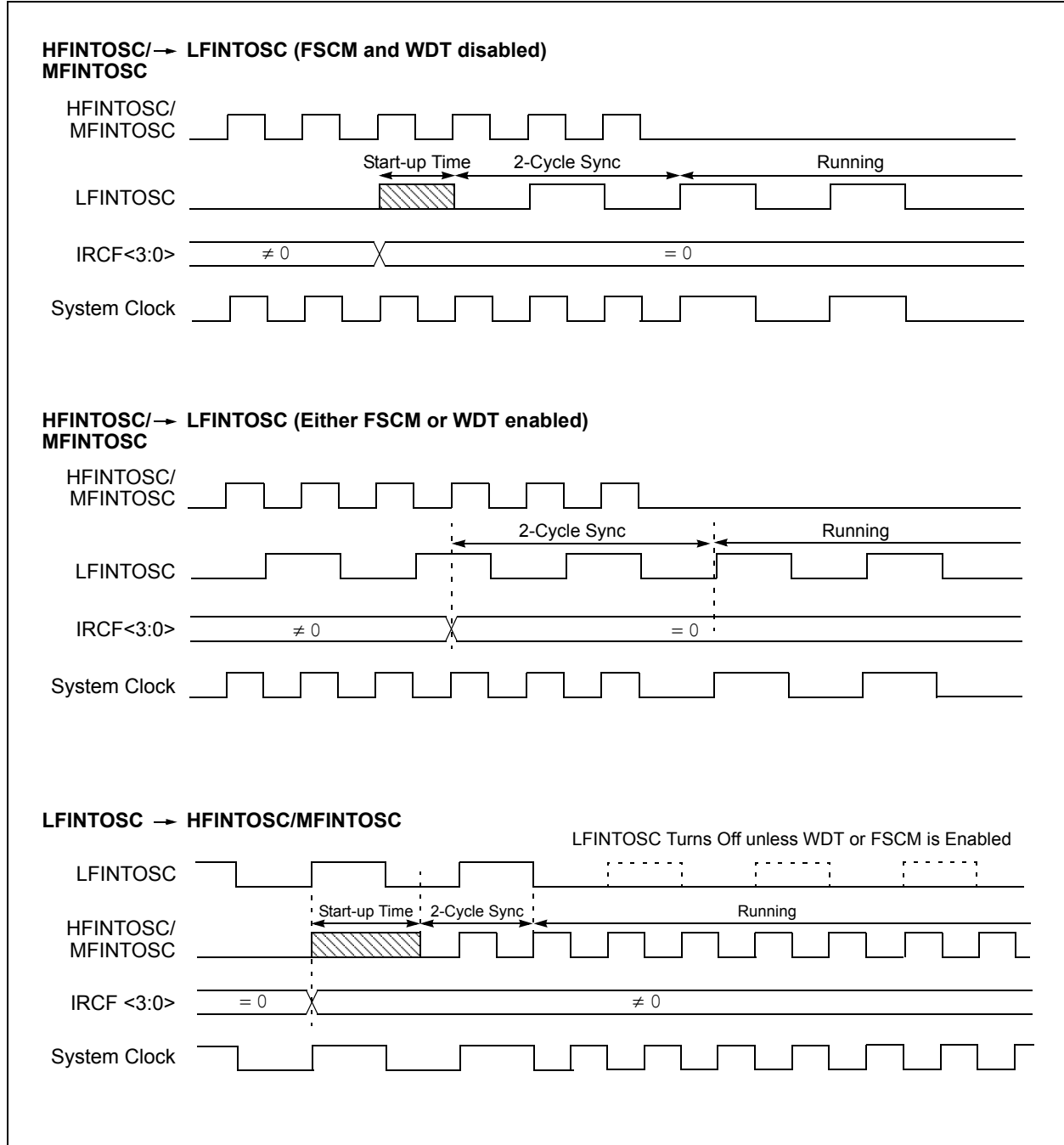
1.  $IRCF<3:0>$  bits of the  $OSCCON$  register are modified.
2. If the new clock is shut down, a clock start-up delay is started.
3. Clock switch circuitry waits for a falling edge of the current clock.
4. The current clock is held low and the clock switch circuitry waits for a rising edge in the new clock.
5. The new clock is now active.
6. The  $OSCSTAT$  register is updated as required.
7. Clock switch is complete.

See [Figure 5-7](#) for more details.

If the internal oscillator speed is switched between two clocks of the same source, there is no start-up delay before the new frequency is selected. Clock switching time delays are shown in [Table 5-1](#).

Start-up delay specifications are located in the oscillator tables of [Section 36.0 "Electrical Specifications"](#).

**FIGURE 5-7: INTERNAL OSCILLATOR SWITCH TIMING**



## 5.3 Clock Switching

The system clock source can be switched between external and internal clock sources via software using the System Clock Select (SCS) bits of the OSCCON register. The following clock sources can be selected using the SCS<1:0> bits:

- Default system oscillator determined by the FOSC<sub>x</sub> bits in the Configuration Words
- Timer1 32 kHz crystal oscillator
- Internal Oscillator Block (INTOSC)

### 5.3.1 SYSTEM CLOCK SELECT (SCS) BITS

The System Clock Select (SCS<1:0>) bits of the OSCCON register select the system clock source that is used for the CPU and peripherals.

- When SCS<1:0> = 00, the system clock source is determined by the value of the FOSC<2:0> bits in the Configuration Words.
- When SCS<1:0> = 01, the system clock source is the secondary oscillator.
- When SCS<1:0> = 1x, the system clock source is chosen by the internal oscillator frequency selected by the IRCF<3:0> bits of the OSCCON register. After a Reset, the SCS<sub>x</sub> bits of the OSCCON register are always cleared.

**Note:** Any automatic clock switch, which may occur from Two-Speed Start-up or Fail-Safe Clock Monitor, does not update the SCS bits of the OSCCON register. The user can monitor the OSTS bit of the OSCSTAT register to determine the current system clock source.

When switching between clock sources, a delay is required to allow the new clock to stabilize. These oscillator delays are shown in [Table 5-1](#).

### 5.3.2 OSCILLATOR START-UP TIMER STATUS (OSTS) BIT

The Oscillator Start-up Timer Status (OSTS) bit of the OSCSTAT register indicates whether the system clock is running from the external clock source, as defined by the FOSC<2:0> bits in the Configuration Words, or from the internal clock source. In particular, OSTS indicates that the Oscillator Start-up Timer (OST) has timed out for LP, XT or HS modes. The OST does not reflect the status of the secondary oscillator.

### 5.3.3 SECONDARY OSCILLATOR

The secondary oscillator is a separate crystal oscillator associated with the Timer1 peripheral. It is optimized for timekeeping operations with a 32.768 kHz crystal connected between the SOSCO and SOSCI device pins.

The secondary oscillator is enabled using the OSCEN control bit in the T1CON register. See [Section 22.0 “Timer1/3/5 Module with Gate Control”](#) for more information about the Timer1 peripheral.

### 5.3.4 SECONDARY OSCILLATOR READY (SOSCR) BIT

The user must ensure that the secondary oscillator is ready to be used before it is selected as a system clock source. The Secondary Oscillator Ready (SOSCR) bit of the OSCSTAT register indicates whether the secondary oscillator is ready to be used. After the SOSCR bit is set, the SCS<sub>x</sub> bits can be configured to select the secondary oscillator.

### 5.3.5 CLOCK SWITCH BEFORE SLEEP

When a clock switch from an old clock to a new clock is requested just prior to entering Sleep mode, it is necessary to confirm that the switch is complete before the sleep instruction is executed. Failure to do so may result in an incomplete switch and consequential loss of the system clock altogether. Clock switching is confirmed by monitoring the clock status bits in the OSCSTAT register. Switch confirmation can be accomplished by sensing that the ready bit for the new clock is set or the ready bit for the old clock is cleared. For example, when switching between the internal oscillator with the PLL and the internal oscillator without the PLL, monitor the PLLR bit. When PLLR is set, the switch to 32 MHz operation is complete. Conversely, when PLLR is cleared, the switch from 32 MHz operation to the selected internal clock is complete.



## 5.4 Two-Speed Clock Start-up Mode

Two-Speed Clock Start-up mode provides additional power savings by minimizing the latency between external oscillator start-up and code execution. In applications that make heavy use of the Sleep mode, Two-Speed Start-up will remove the external oscillator start-up time from the time spent awake and can reduce the overall power consumption of the device. This mode allows the application to wake-up from Sleep, perform a few instructions using the Internal Oscillator Block, INTOSC, as the clock source and go back to Sleep without waiting for the external oscillator to become stable.

Two-Speed Start-up provides benefits when the oscillator module is configured for LP, XT or HS modes. The Oscillator Start-up Timer (OST) is enabled for these modes and must count 1024 oscillations before the oscillator can be used as the system clock source.

If the oscillator module is configured for any mode other than LP, XT or HS mode, then Two-Speed Start-up is disabled. This is because the external clock oscillator does not require any stabilization time after POR or an exit from Sleep.

If the OST count reaches 1024 before the device enters Sleep mode, the OSTS bit of the OSCSTAT register is set and program execution switches to the external oscillator. However, the system may never operate from the external oscillator if the time spent awake is very short.

**Note:** Executing a SLEEP instruction will abort the oscillator start-up time and will cause the OSTS bit of the OSCSTAT register to remain clear.

### 5.4.1 TWO-SPEED START-UP MODE CONFIGURATION

Two-Speed Start-up mode is configured by the following settings:

- IESO (of the Configuration Words) = 1; Internal/External Switchover bit (Two-Speed Start-up mode enabled).
- SCS<1:0> (of the OSCCON register) = 00.
- FOSC<2:0> bits in the Configuration Words configured for LP, XT or HS mode.

Two-Speed Start-up mode is entered after:

- Power-on Reset (POR) and, if enabled, after Power-up Timer (PWRT) has expired, or
- Wake-up from Sleep.

**TABLE 5-1: OSCILLATOR SWITCHING DELAYS**

Switch From	Switch To	Frequency	Oscillator Delay
Sleep	LFINTOSC MFINTOSC HFINTOSC <sup>(1)</sup>	31 kHz 31.25 kHz-500 kHz 31.25 kHz-16 MHz	Oscillator Warm-up Delay (TWARM) <sup>(2)</sup>
Sleep	EC, RC <sup>(1)</sup>	DC- 32 MHz	2 cycles
LFINTOSC	EC, RC <sup>(1)</sup>	DC-32 MHz	1 Cycle of Each
Sleep	Secondary Oscillator LP, XT, HS <sup>(1)</sup>	32 kHz-20 MHz	1024 Clock Cycles (OST)
Any Clock Source	MFINTOSC HFINTOSC <sup>(1)</sup>	31.25 kHz-500 kHz 31.25 kHz-16 MHz	2 μs (approx.)
Any Clock Source	LFINTOSC	31 kHz	1 Cycle of Each
Any Clock Source	Secondary Oscillator	32 kHz	1024 Clock Cycles (OST)
PLL Inactive	PLL Active	16-32 MHz	2 ms (approx.)

**Note 1:** PLL is inactive.

**2:** See [Table 36-8](#).



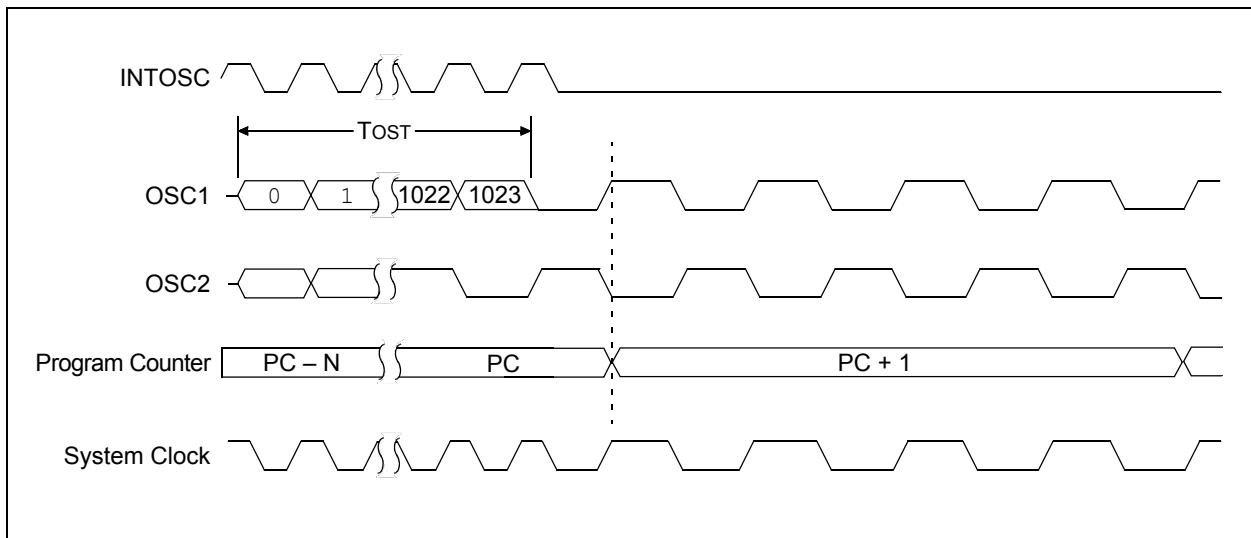
## 5.4.2 TWO-SPEED START-UP SEQUENCE

1. Wake-up from Power-on Reset or Sleep.
2. Instructions begin execution by the internal oscillator at the frequency set in the IRCF<3:0> bits of the OSCCON register.
3. OST enabled to count 1024 clock cycles.
4. OST timed out, wait for falling edge of the internal oscillator.
5. OSTS is set.
6. System clock held low until the next falling edge of new clock (LP, XT or HS mode).
7. System clock is switched to external clock source.

## 5.4.3 CHECKING TWO-SPEED CLOCK STATUS

Checking the state of the OSTS bit of the OSCSTAT register will confirm if the microcontroller is running from the external clock source, as defined by the FOSC<2:0> bits in the Configuration Words, or the internal oscillator.

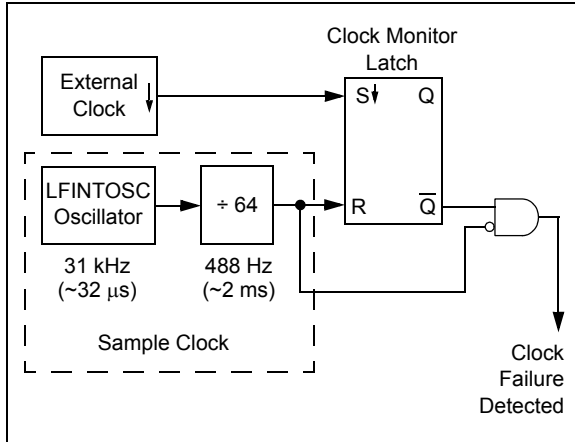
**FIGURE 5-8: TWO-SPEED START-UP**



## 5.5 Fail-Safe Clock Monitor

The Fail-Safe Clock Monitor (FSCM) allows the device to continue operating should the external oscillator fail. The FSCM can detect oscillator failure any time after the Oscillator Start-up Timer (OST) has expired. The FSCM is enabled by setting the FCMEN bit in the Configuration Words. The FSCM is applicable to all external Oscillator modes (LP, XT, HS, EC, Secondary Oscillator and RC).

**FIGURE 5-9: FSCM BLOCK DIAGRAM**



### 5.5.1 FAIL-SAFE DETECTION

The FSCM module detects a failed oscillator by comparing the external oscillator to the FSCM sample clock. The sample clock is generated by dividing the LFINTOSC by 64. See [Figure 5-9](#). Inside the fail detector block is a latch. The external clock sets the latch on each falling edge of the external clock. The sample clock clears the latch on each rising edge of the sample clock. A failure is detected when an entire half-cycle of the sample clock elapses before the external clock goes low.

### 5.5.2 FAIL-SAFE OPERATION

When the external clock fails, the FSCM switches the device clock to an internal clock source and sets the bit flag OSFIF of the PIR2 register. Setting this flag will generate an interrupt if the OSFIE bit of the PIE2 register is also set. The device firmware can then take steps to mitigate the problems that may arise from a failed clock. The system clock will continue to be sourced from the internal clock source until the device firmware successfully restarts the external oscillator and switches back to external operation.

The internal clock source chosen by the FSCM is determined by the IRCF<3:0> bits of the OSCCON register. This allows the internal oscillator to be configured before a failure occurs.

### 5.5.3 FAIL-SAFE CONDITION CLEARING

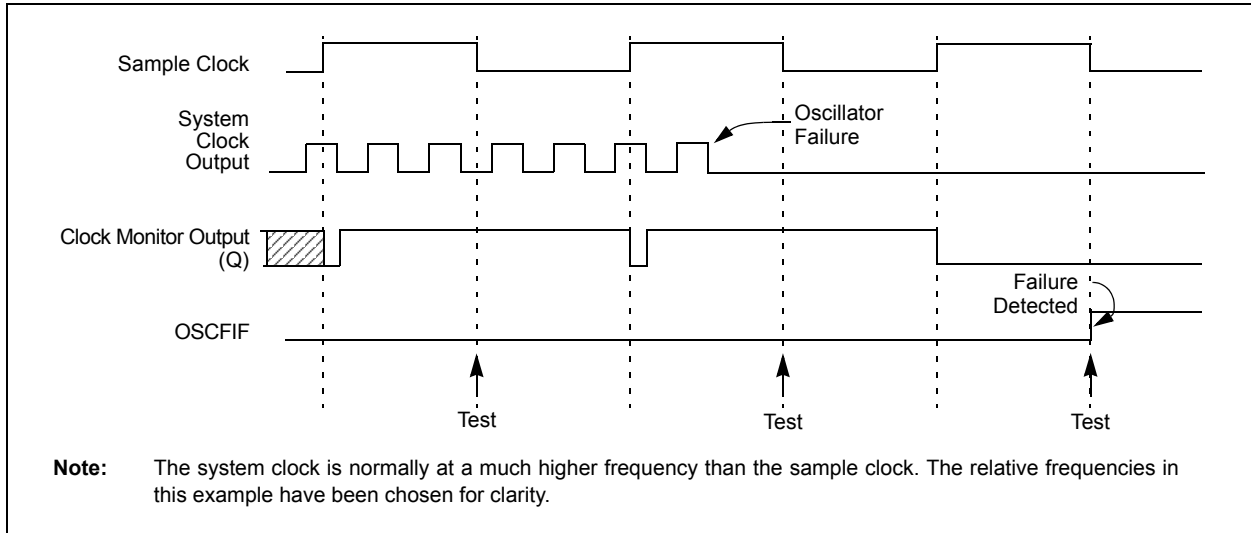
The Fail-Safe condition is cleared after a Reset, executing a `SLEEP` instruction or changing the SCSx bits of the OSCCON register. When the SCSx bits are changed, the OST is restarted. While the OST is running, the device continues to operate from the INTOSC selected in OSCCON. When the OST times out, the Fail-Safe condition is cleared after successfully switching to the external clock source. The OSFIF bit should be cleared prior to switching to the external clock source. If the Fail-Safe condition still exists, the OSFIF flag will again become set by hardware.

### 5.5.4 RESET OR WAKE-UP FROM SLEEP

The FSCM is designed to detect an oscillator failure after the Oscillator Start-up Timer (OST) has expired. The OST is used after waking up from Sleep and after any type of Reset. The OST is not used with the EC or RC Clock modes so that the FSCM will be active as soon as the Reset or wake-up has completed. When the FSCM is enabled, the Two-Speed Start-up is also enabled. Therefore, the device will always be executing code while the OST is operating.

**Note:** Due to the wide range of oscillator start-up times, the Fail-Safe circuit is not active during oscillator start-up (i.e., after exiting Reset or Sleep). After an appropriate amount of time, the user should check the status bits in the OSCSTAT register to verify the oscillator start-up and that the system clock switchover has successfully completed.

**FIGURE 5-10: FSCM TIMING DIAGRAM**



## 5.6 Register Definitions: Oscillator Control

### REGISTER 5-1: OSCCON: OSCILLATOR CONTROL REGISTER

R/W-0/0	R/W-0/0	R/W-1/1	R/W-1/1	R/W-1/1	U-0	R/W-0/0	R/W-0/0
SPLLEN	IRCF<3:0>			—	SCS<1:0>		
bit 7							bit 0

#### Legend:

R = Readable bit	W = Writable bit	
u = Bit is unchanged	x = Bit is unknown	U = Unimplemented bit, read as '0'
'1' = Bit is set	'0' = Bit is cleared	-n/n = Value at POR and BOR/Value at all other Resets

- bit 7      **SPLLEN:** Software PLL Enable bit  
If PLEN in Configuration Words = 1:  
 SPLLEN bit is ignored; 4x PLL is always enabled (subject to oscillator requirements).  
If PLEN in Configuration Words = 0:  
 1 = 4x PLL is enabled  
 0 = 4x PLL is disabled
- bit 6-3    **IRCF<3:0>:** Internal Oscillator Frequency Select bits  
 1111 = 16 MHz HF  
 1110 = 8 MHz or 32 MHz HF<sup>(2)</sup>  
 1101 = 4 MHz HF  
 1100 = 2 MHz HF  
 1011 = 1 MHz HF  
 1010 = 500 kHz HF<sup>(1)</sup>  
 1001 = 250 kHz HF<sup>(1)</sup>  
 1000 = 125 kHz HF<sup>(1)</sup>  
 0111 = 500 kHz MF (default upon Reset)  
 0110 = 250 kHz MF  
 0101 = 125 kHz MF  
 0100 = 62.5 kHz MF  
 0011 = 31.25 kHz HF<sup>(1)</sup>  
 0010 = 31.25 kHz MF  
 000x = 31 kHz LF
- bit 2      **Unimplemented:** Read as '0'
- bit 1-0    **SCS<1:0>:** System Clock Select bits  
 1x = Internal Oscillator Block  
 01 = Secondary oscillator  
 00 = Clock determined by FOSC<2:0> in the Configuration Words

- Note 1:** Duplicate frequency derived from HFINTOSC.  
**2:** 32 MHz when SPLLEN bit is set. Refer to [Section 5.2.2.6 “32 MHz Internal Oscillator Frequency Selection”](#).

## REGISTER 5-2: OSCSTAT: OSCILLATOR STATUS REGISTER

R-1/q	R-0/q	R-q/q	R-0/q	R-0/q	R-q/q	R-0/0	R-0/q
SOSCR	PLLr	OSTS	HFIOFR	HFIOFL	MFIOFR	LFIOFR	HFIOFS
bit 7							bit 0

### Legend:

R = Readable bit	W = Writable bit	q = Conditional
u = Bit is unchanged	x = Bit is unknown	U = Unimplemented bit, read as '0'
'1' = Bit is set	'0' = Bit is cleared	-n/n = Value at POR and BOR/Value at all other Resets

bit 7	<p><b>SOSCR:</b> Secondary Oscillator Ready bit</p> <p><u>If T1OSCEN = 1:</u></p> <p>1 = Secondary oscillator is ready</p> <p>0 = Secondary oscillator is not ready</p> <p><u>If T1OSCEN = 0:</u></p> <p>1 = Secondary clock source is always ready</p>
bit 6	<p><b>PLLr</b> 4x PLL Ready bit</p> <p>1 = 4x PLL is ready</p> <p>0 = 4x PLL is not ready</p>
bit 5	<p><b>OSTS:</b> Oscillator Start-up Timer Status bit</p> <p>1 = Running from the clock defined by the FOSC&lt;2:0&gt; bits of the Configuration Words</p> <p>0 = Running from an internal oscillator (FOSC&lt;2:0&gt; = 100)</p>
bit 4	<p><b>HFIOFR:</b> High-Frequency Internal Oscillator Ready bit</p> <p>1 = HFINTOSC is ready</p> <p>0 = HFINTOSC is not ready</p>
bit 3	<p><b>HFIOFL:</b> High-Frequency Internal Oscillator Locked bit</p> <p>1 = HFINTOSC is at least 2% accurate</p> <p>0 = HFINTOSC is not 2% accurate</p>
bit 2	<p><b>MFIOFR:</b> Medium Frequency Internal Oscillator Ready bit</p> <p>1 = MFINTOSC is ready</p> <p>0 = MFINTOSC is not ready</p>
bit 1	<p><b>LFIOFR:</b> Low-Frequency Internal Oscillator Ready bit</p> <p>1 = LFINTOSC is ready</p> <p>0 = LFINTOSC is not ready</p>
bit 0	<p><b>HFIOFS:</b> High-Frequency Internal Oscillator Stable bit</p> <p>1 = HFINTOSC is at least 0.5% accurate</p> <p>0 = HFINTOSC is not 0.5% accurate</p>

# PIC16(L)F1764/5/8/9

**REGISTER 5-3: OSCTUNE: OSCILLATOR TUNING REGISTER**

U-0	U-0	R/W-0/0	R/W-0/0	R/W-0/0	R/W-0/0	R/W-0/0	R/W-0/0
—	—	TUN<5:0>					
bit 7							bit 0

<b>Legend:</b>		
R = Readable bit	W = Writable bit	
u = Bit is unchanged	x = Bit is unknown	U = Unimplemented bit, read as '0'
'1' = Bit is set	'0' = Bit is cleared	-n/n = Value at POR and BOR/Value at all other Resets

bit 7-6      **Unimplemented:** Read as '0'

bit 5-0      **TUN<5:0>:** Frequency Tuning bits

              100000 = Minimum frequency

              •

              •

              •

              111111 =

              000000 = Oscillator module is running at the factory-calibrated frequency

              000001 =

              •

              •

              •

              011110 =

              011111 = Maximum frequency

**TABLE 5-2: SUMMARY OF REGISTERS ASSOCIATED WITH CLOCK SOURCES**

Name	Bit 7	Bit 6	Bit 5	Bit 4	Bit 3	Bit 2	Bit 1	Bit 0	Register on Page
OSCCON	SPLLEN	IRCF<3:0>				—	SCS<1:0>		84
OSCSTAT	SOSCR	PLLR	OSTS	HFIOFR	HFIOFL	MFIOFR	LFIOFR	HFIOFS	85
OSCTUNE	—	—	TUN<5:0>						86
PIR2	OSFIF	C2IF	C1IF	—	BCL1IF	C4IF <sup>(1)</sup>	C3IF <sup>(1)</sup>	CCP2IF <sup>(1)</sup>	107
PIE2	OSFIE	C2IE	C1IE	—	BCL1IE	C4IE <sup>(1)</sup>	C3IE <sup>(1)</sup>	CCP2IE <sup>(1)</sup>	103
T1CON	CS<1:0>		CKPS<1:0>		OScen	SYN $\bar{C}$	—	ON	225

**Legend:** — = unimplemented location, read as '0'. Shaded cells are not used by clock sources.

**Note 1:** PIC16(L)F1768/9 only.

**TABLE 5-3: SUMMARY OF CONFIGURATION WORD WITH CLOCK SOURCES**

Name	Bits	Bit -7	Bit -6	Bit 13/5	Bit 12/4	Bit 11/3	Bit 10/2	Bit 9/1	Bit 8/0	Register on Page
CONFIG1	13:8	—	—	FCMEN	IESO	CLKOUTEN	BOREN<1:0>		—	63
	7:0	CP	MCLRE	PWRTE	WDTE<1:0>		FOSC<2:0>			

**Legend:** — = unimplemented location, read as '0'. Shaded cells are not used by clock sources.

## 6.0 RESETS

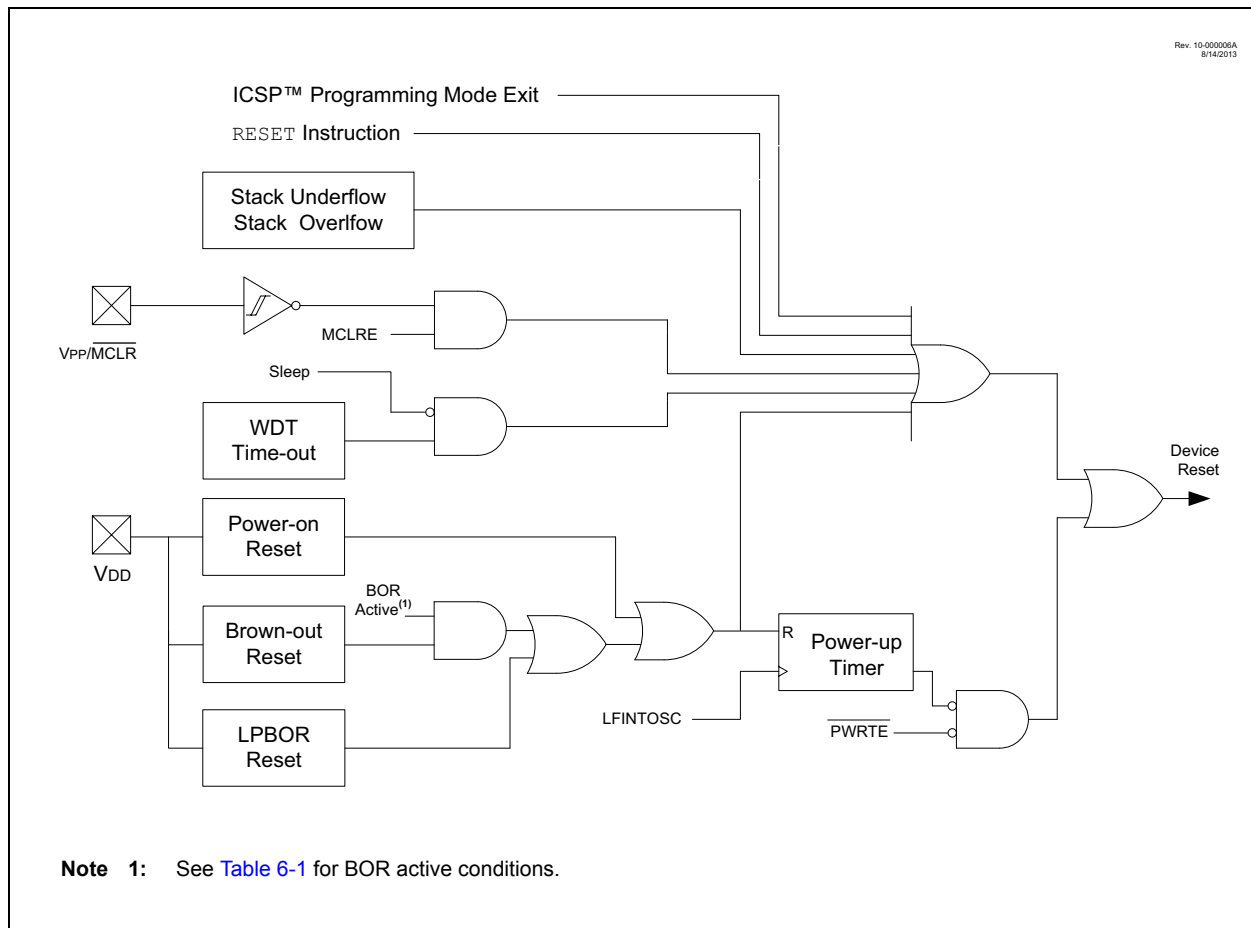
There are multiple ways to reset this device:

- Power-on Reset (POR)
- Brown-out Reset (BOR)
- Low-Power Brown-out Reset (LPBOR)
- MCLR Reset
- WDT Reset
- RESET instruction
- Stack Overflow
- Stack Underflow
- Programming mode exit

To allow V<sub>DD</sub> to stabilize, an optional power-up timer can be enabled to extend the Reset time after a BOR or POR event.

A simplified block diagram of the On-Chip Reset Circuit is shown in [Figure 6-1](#).

**FIGURE 6-1: SIMPLIFIED BLOCK DIAGRAM OF ON-CHIP RESET CIRCUIT**



## 6.1 Power-on Reset (POR)

The POR circuit holds the device in Reset until VDD has reached an acceptable level for minimum operation. Slow rising VDD, fast operating speeds or analog performance may require greater than minimum VDD. The PWRT, BOR or MCLR features can be used to extend the start-up period until all device operation conditions have been met.

### 6.1.1 POWER-UP TIMER (PWRT)

The Power-up Timer provides a nominal 64 ms time-out on POR or Brown-out Reset.

The device is held in Reset as long as PWRT is active. The PWRT delay allows additional time for the VDD to rise to an acceptable level. The Power-up Timer is enabled by clearing the PWRT<sub>EN</sub> bit in the Configuration Words.

The Power-up Timer starts after the release of the POR and BOR.

For additional information, refer to Application Note AN607, "Power-up Trouble Shooting" (DS00607).

## 6.2 Brown-out Reset (BOR)

The BOR circuit holds the device in Reset when VDD reaches a selectable minimum level. Between the POR and BOR, complete voltage range coverage for execution protection can be implemented.

The Brown-out Reset module has four operating modes controlled by the BOREN<1:0> bits in the Configuration Words. The four operating modes are:

- BOR is always on
- BOR is off when in Sleep
- BOR is controlled by software
- BOR is always off

Refer to [Table 6-1](#) for more information.

The Brown-out Reset voltage level is selectable by configuring the BORV bit in the Configuration Words.

A VDD noise rejection filter prevents the BOR from triggering on small events. If VDD falls below V<sub>BOR</sub> for a duration greater than parameter, T<sub>BORDC</sub>, the device will reset. See [Figure 6-2](#) for more information.

**TABLE 6-1: BOR OPERATING MODES**

BOREN<1:0>	SBOREN	Device Mode	BOR Mode	Instruction Execution upon: Release of POR or Wake-up from Sleep
11	x	X	Active	Waits for BOR ready (BORRDY = 1) <sup>(1)</sup>
10	x	Awake	Active	Waits for BOR ready (BORRDY = 1)
		Sleep	Disabled	
01	1	X	Active	Waits for BOR ready (BORRDY = 1) <sup>(1)</sup>
	0	X	Disabled	Begins immediately (BORRDY = x)
00	x	X	Disabled	

**Note 1:** In these specific cases, "Release of POR" and "Wake-up from Sleep", there is no delay in start-up. The BOR Ready Flag (BORRDY = 1) will be set before the CPU is ready to execute instructions because the BOR circuit is forced on by the BOREN<1:0> bits.



## 6.2.1 BOR IS ALWAYS ON

When the BOREN<1:0> bits of the Configuration Words are programmed to '11', the BOR is always on. The device start-up will be delayed until the BOR is ready and VDD is higher than the BOR threshold.

BOR protection is active during Sleep. The BOR does not delay wake-up from Sleep.

## 6.2.2 BOR IS OFF IN SLEEP

When the BORENx bits of the Configuration Words are programmed to '10', the BOR is on, except in Sleep. The device start-up will be delayed until the BOR is ready and VDD is higher than the BOR threshold.

BOR protection is not active during Sleep. The device wake-up will be delayed until the BOR is ready.

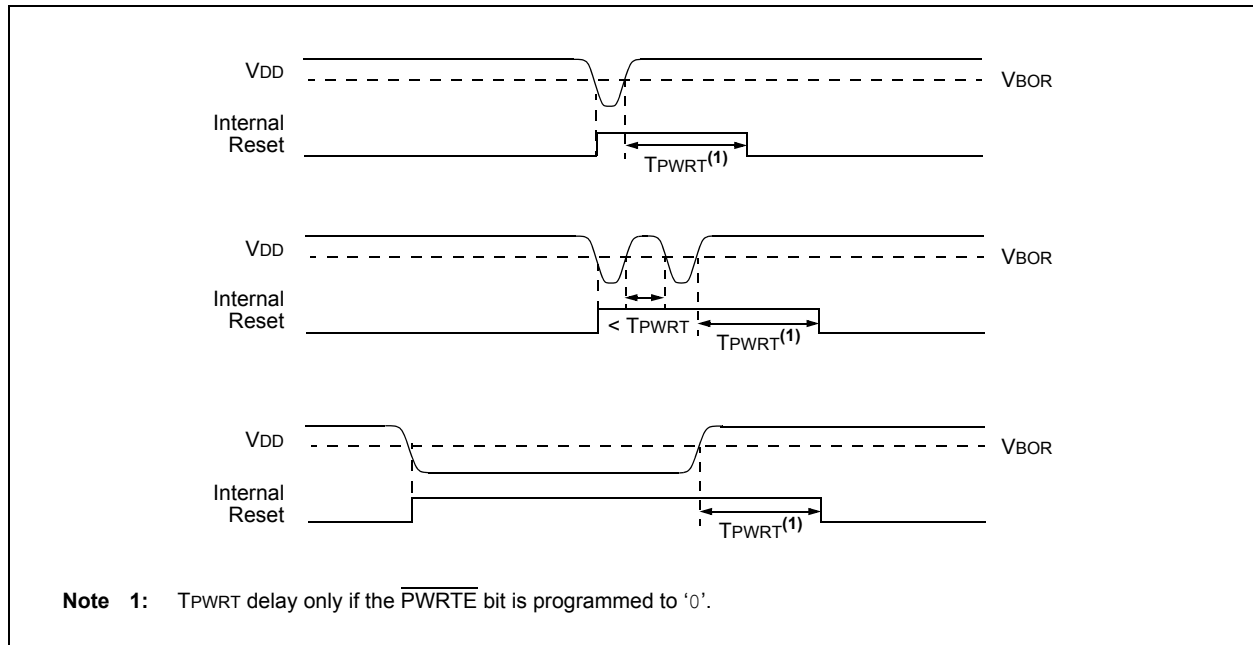
## 6.2.3 BOR CONTROLLED BY SOFTWARE

When the BORENx bits of the Configuration Words are programmed to '01', the BOR is controlled by the SBORREN bit of the BORCON register. The device start-up is not delayed by the BOR ready condition or the VDD level.

BOR protection begins as soon as the BOR circuit is ready. The status of the BOR circuit is reflected in the BORRDY bit of the BORCON register.

BOR protection is unchanged by Sleep.

**FIGURE 6-2: BROWN-OUT SITUATIONS**



## 6.3 Register Definitions: BOR Control

### REGISTER 6-1: BORCON: BROWN-OUT RESET CONTROL REGISTER

R/W-1/u	R/W-0/u	U-0	U-0	U-0	U-0	U-0	R-q/u
SBOREN	BORFS <sup>(1)</sup>	—	—	—	—	—	BORRDY
bit 7							bit 0

#### Legend:

R = Readable bit	W = Writable bit	q = Value depends on condition
u = Bit is unchanged	x = Bit is unknown	U = Unimplemented bit, read as '0'
'1' = Bit is set	'0' = Bit is cleared	-n/n = Value at POR and BOR/Value at all other Resets

bit 7 **SBOREN:** Software Brown-out Reset Enable bit

If BOREN <1:0> in Configuration Words ≠ 01:  
SBOREN is read/write, but has no effect on the BOR.

If BOREN <1:0> in Configuration Words = 01:

1 = BOR is enabled

0 = BOR is disabled

bit 6 **BORFS:** Brown-out Reset Fast Start bit<sup>(1)</sup>

If BOREN<1:0> = 11 (always on) or BOREN<1:0> = 00 (always off):

BORFS is Read/Write, but has no effect.

If BOREN <1:0> = 10 (disabled in Sleep) or BOREN<1:0> = 01 (under software control):

1 = Band gap is forced on always (covers Sleep/wake-up/operating cases)

0 = Band gap operates normally and may turn off

bit 5-1 **Unimplemented:** Read as '0'

bit 0 **BORRDY:** Brown-out Reset Circuit Ready Status bit

1 = The Brown-out Reset circuit is active

0 = The Brown-out Reset circuit is inactive

**Note 1:** The BOREN<1:0> bits are located in the Configuration Words.

## 6.4 Low-Power Brown-out Reset (LPBOR)

The Low-Power Brown-out Reset (LPBOR) is an essential part of the Reset subsystem. Refer to [Figure 6-1](#) to see how the BOR interacts with other modules.

The LPBOR is used to monitor the external VDD pin. When too low of a voltage is detected, the device is held in Reset. When this occurs, a register bit ( $\overline{\text{BOR}}$ ) is changed to indicate that a BOR Reset has occurred. The same bit is set for both the BOR and the LPBOR. Refer to [Register 6-2](#).

### 6.4.1 ENABLING LPBOR

The LPBOR is controlled by the  $\overline{\text{LPBOR}}$  bit of the Configuration Words. When the device is erased, the LPBOR module defaults to disabled.

#### 6.4.1.1 LPBOR Module Output

The output of the LPBOR module is a signal indicating whether or not a Reset is to be asserted. This signal is OR'd together with the Reset signal of the BOR module to provide the generic  $\overline{\text{BOR}}$  signal, which goes to the PCON register and to the power control block.

## 6.5 $\overline{\text{MCLR}}$

The  $\overline{\text{MCLR}}$  is an optional external input that can reset the device. The  $\overline{\text{MCLR}}$  function is controlled by the MCLRE and the LVP bits of the Configuration Words ([Table 6-2](#)).

**TABLE 6-2:  $\overline{\text{MCLR}}$  CONFIGURATION**

MCLRE	LVP	$\overline{\text{MCLR}}$
0	0	Disabled
1	0	Enabled
x	1	Enabled

### 6.5.1 $\overline{\text{MCLR}}$ ENABLED

When  $\overline{\text{MCLR}}$  is enabled and the pin is held low, the device is held in Reset. The  $\overline{\text{MCLR}}$  pin is connected to VDD through an internal weak pull-up.

The device has a noise filter in the  $\overline{\text{MCLR}}$  Reset path. The filter will detect and ignore small pulses.

**Note:** A Reset does not drive the  $\overline{\text{MCLR}}$  pin low.

### 6.5.2 $\overline{\text{MCLR}}$ DISABLED

When  $\overline{\text{MCLR}}$  is disabled, the pin functions as a general purpose input and the internal weak pull-up is under software control. See [Section 11.1 “PORTA Registers”](#) for more information.

## 6.6 Watchdog Timer (WDT) Reset

The Watchdog Timer generates a Reset if the firmware does not issue a  $\overline{\text{CLRWDT}}$  instruction within the time-out period. The  $\overline{\text{TO}}$  and  $\overline{\text{PD}}$  bits in the STATUS register are changed to indicate the WDT Reset. See [Section 9.0 “Watchdog Timer \(WDT\)”](#) for more information.

## 6.7 RESET Instruction

A  $\overline{\text{RESET}}$  instruction will cause a device Reset. The  $\overline{\text{RI}}$  bit in the PCON register will be set to '0'. See [Table 6-4](#) for default conditions after a  $\overline{\text{RESET}}$  instruction has occurred.

## 6.8 Stack Overflow/Underflow Reset

The device can reset when the Stack Overflows or Underflows. The STKOVF or STKUNF bits of the PCON register indicate the Reset condition. These Resets are enabled by setting the STVREN bit in the Configuration Words. See [Section 3.5.2 “Overflow/Underflow Reset”](#) for more information.

## 6.9 Programming Mode Exit

Upon exit of Programming mode, the device will behave as if a POR had just occurred.

## 6.10 Power-up Timer

The Power-up Timer optionally delays device execution after a BOR or POR event. This timer is typically used to allow VDD to stabilize before allowing the device to start running.

The Power-up Timer is controlled by the  $\overline{\text{PWRTEN}}$  bit of the Configuration Words.

## 6.11 Start-up Sequence

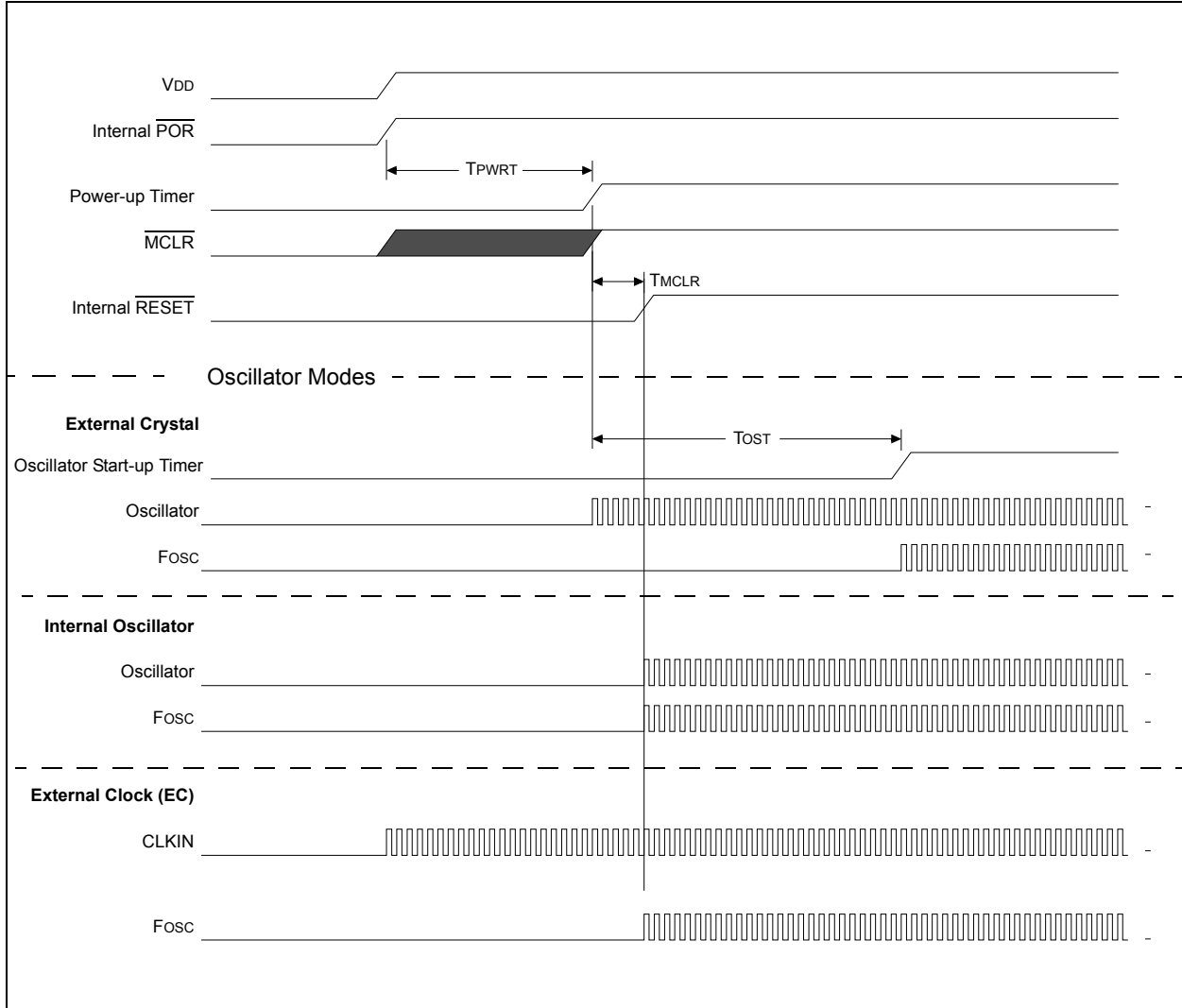
Upon the release of a POR or BOR, the following must occur before the device will begin executing:

1. Power-up Timer runs to completion (if enabled).
2. Oscillator Start-up Timer runs to completion (if required for oscillator source).
3.  $\overline{\text{MCLR}}$  must be released (if enabled).

The total time-out will vary based on oscillator configuration and Power-up Timer configuration. See [Section 5.0 “Oscillator Module \(with Fail-Safe Clock Monitor\)”](#) for more information.

The Power-up Timer and Oscillator Start-up Timer run independently of  $\overline{\text{MCLR}}$  Reset. If  $\overline{\text{MCLR}}$  is kept low long enough, the Power-up Timer and Oscillator Start-up Timer will expire. Upon bringing  $\overline{\text{MCLR}}$  high, the device will begin execution after 10 Fosc cycles (see [Figure 6-3](#)). This is useful for testing purposes or to synchronize more than one device operating in parallel.

**FIGURE 6-3: RESET START-UP SEQUENCE**



## 6.12 Determining the Cause of a Reset

Upon any Reset, multiple bits in the STATUS and PCON registers are updated to indicate the cause of the Reset. Table 6-3 and Table 6-4 show the Reset conditions of these registers.

**TABLE 6-3: RESET STATUS BITS AND THEIR SIGNIFICANCE**

STKOVF	STKUNF	RWD $\bar{T}$	RMCL $\bar{R}$	RI	POR	BOR	TO	PD	Condition
0	0	1	1	1	0	x	1	1	Power-on Reset
0	0	1	1	1	0	x	0	x	Illegal, $\bar{T}O$ is set on $\bar{P}OR$
0	0	1	1	1	0	x	x	0	Illegal, $\bar{P}D$ is set on $\bar{P}OR$
0	0	u	1	1	u	0	1	1	Brown-out Reset
u	u	0	u	u	u	u	0	u	WDT Reset
u	u	u	u	u	u	u	0	0	WDT Wake-up from Sleep
u	u	u	u	u	u	u	1	0	Interrupt Wake-up from Sleep
u	u	u	0	u	u	u	u	u	$\bar{M}CLR$ Reset during Normal Operation
u	u	u	0	u	u	u	1	0	$\bar{M}CLR$ Reset during Sleep
u	u	u	u	0	u	u	u	u	RESET Instruction Executed
1	u	u	u	u	u	u	u	u	Stack Overflow Reset (STVREN = 1)
u	1	u	u	u	u	u	u	u	Stack Underflow Reset (STVREN = 1)

**TABLE 6-4: RESET CONDITION FOR SPECIAL REGISTERS**

Condition	Program Counter	STATUS Register	PCON Register
Power-on Reset	0000h	---1 1000	00-- 110x
$\bar{M}CLR$ Reset during Normal Operation	0000h	---u uuuu	uu-- 0uuu
$\bar{M}CLR$ Reset during Sleep	0000h	---1 0uuu	uu-- 0uuu
WDT Reset	0000h	---0 uuuu	uu-- uuuu
WDT Wake-up from Sleep	PC + 1	---0 0uuu	uu-- uuuu
Brown-out Reset	0000h	---1 1uuu	00-- 11u0
Interrupt Wake-up from Sleep	PC + 1 <sup>(1)</sup>	---1 0uuu	uu-- uuuu
RESET Instruction Executed	0000h	---u uuuu	uu-- u0uu
Stack Overflow Reset (STVREN = 1)	0000h	---u uuuu	1u-- uuuu
Stack Underflow Reset (STVREN = 1)	0000h	---u uuuu	u1-- uuuu

**Legend:** u = unchanged; x = unknown; - = unimplemented bit, reads as '0'.

**Note 1:** When the wake-up is due to an interrupt and Global Interrupt Enable bit (GIE) is set, the return address is pushed onto the stack and the PC is loaded with the interrupt vector (0004h) after execution of PC + 1.

## 6.13 Power Control (PCON) Register

The PCON register bits are shown in [Register 6-2](#).

The Power Control (PCON) register contains flag bits to differentiate between a:

- Power-on Reset ( $\overline{\text{POR}}$ )
- Brown-out Reset ( $\overline{\text{BOR}}$ )
- Reset Instruction Reset ( $\overline{\text{RI}}$ )
- MCLR Reset ( $\overline{\text{RMCLR}}$ )
- Watchdog Timer Reset ( $\overline{\text{RWDT}}$ )
- Stack Underflow Reset (STKUNF)
- Stack Overflow Reset (STKOVF)

## 6.14 Register Definitions: Power Control

### REGISTER 6-2: PCON: POWER CONTROL REGISTER

R/W/HS-0/q	R/W/HS-0/q	U-0	R/W/HC-1/q	R/W/HC-1/q	R/W/HC-1/q	R/W/HC-q/u	R/W/HC-q/u
STKOVF	STKUNF	—	$\overline{\text{RWDT}}$	$\overline{\text{RMCLR}}$	$\overline{\text{RI}}$	$\overline{\text{POR}}$	$\overline{\text{BOR}}$
bit 7						bit 0	

<b>Legend:</b>	HC = Hardware Clearable bit	HS = Hardware Settable bit
R = Readable bit	W = Writable bit	U = Unimplemented bit, read as '0'
u = Bit is unchanged	x = Bit is unknown	-m/n = Value at POR and BOR/Value at all other Resets
'1' = Bit is set	'0' = Bit is cleared	q = Value depends on condition

bit 7	<b>STKOVF:</b> Stack Overflow Flag bit 1 = A Stack Overflow occurred 0 = A Stack Overflow has not occurred or is cleared by firmware
bit 6	<b>STKUNF:</b> Stack Underflow Flag bit 1 = A Stack Underflow occurred 0 = A Stack Underflow has not occurred or is cleared by firmware
bit 5	<b>Unimplemented:</b> Read as '0'
bit 4	<b><math>\overline{\text{RWDT}}</math>:</b> Watchdog Timer Reset Flag bit 1 = A Watchdog Timer Reset has not occurred or is set to '1' by firmware 0 = A Watchdog Timer Reset has occurred (cleared by hardware)
bit 3	<b><math>\overline{\text{RMCLR}}</math>:</b> $\overline{\text{MCLR}}$ Reset Flag bit 1 = A $\overline{\text{MCLR}}$ Reset has not occurred or is set to '1' by firmware 0 = A $\overline{\text{MCLR}}$ Reset has occurred (cleared by hardware)
bit 2	<b><math>\overline{\text{RI}}</math>:</b> $\overline{\text{RESET}}$ Instruction Flag bit 1 = A $\overline{\text{RESET}}$ instruction has not been executed or is set to '1' by firmware 0 = A $\overline{\text{RESET}}$ instruction has been executed (cleared by hardware)
bit 1	<b><math>\overline{\text{POR}}</math>:</b> Power-on Reset Status bit 1 = No Power-on Reset occurred 0 = A Power-on Reset occurred (must be set in software after a Power-on Reset occurs)
bit 0	<b><math>\overline{\text{BOR}}</math>:</b> Brown-out Reset Status bit 1 = No Brown-out Reset occurred 0 = A Brown-out Reset occurred (must be set in software after a Power-on Reset or Brown-out Reset occurs)

# PIC16(L)F1764/5/8/9

**TABLE 6-5: SUMMARY OF REGISTERS ASSOCIATED WITH RESETS**

Name	Bit 7	Bit 6	Bit 5	Bit 4	Bit 3	Bit 2	Bit 1	Bit 0	Register on Page
BORCON	SBOREN	BORFS	—	—	—	—	—	BORRDY	<a href="#">90</a>
PCON	STKOVF	STKUNF	—	$\overline{\text{RWDT}}$	$\overline{\text{RMCLR}}$	$\overline{\text{RI}}$	$\overline{\text{POR}}$	$\overline{\text{BOR}}$	<a href="#">94</a>
STATUS	—	—	—	$\overline{\text{TO}}$	$\overline{\text{PD}}$	Z	DC	C	<a href="#">27</a>
WDTCON	—	—	WDTPS<4:0>					SWDTEN	<a href="#">117</a>

**Legend:** — = unimplemented location, read as '0'. Shaded cells are not used by Resets.

## 7.0 INTERRUPTS

The interrupt feature allows certain events to preempt normal program flow. Firmware is used to determine the source of the interrupt and act accordingly. Some interrupts can be configured to wake the MCU from Sleep mode.

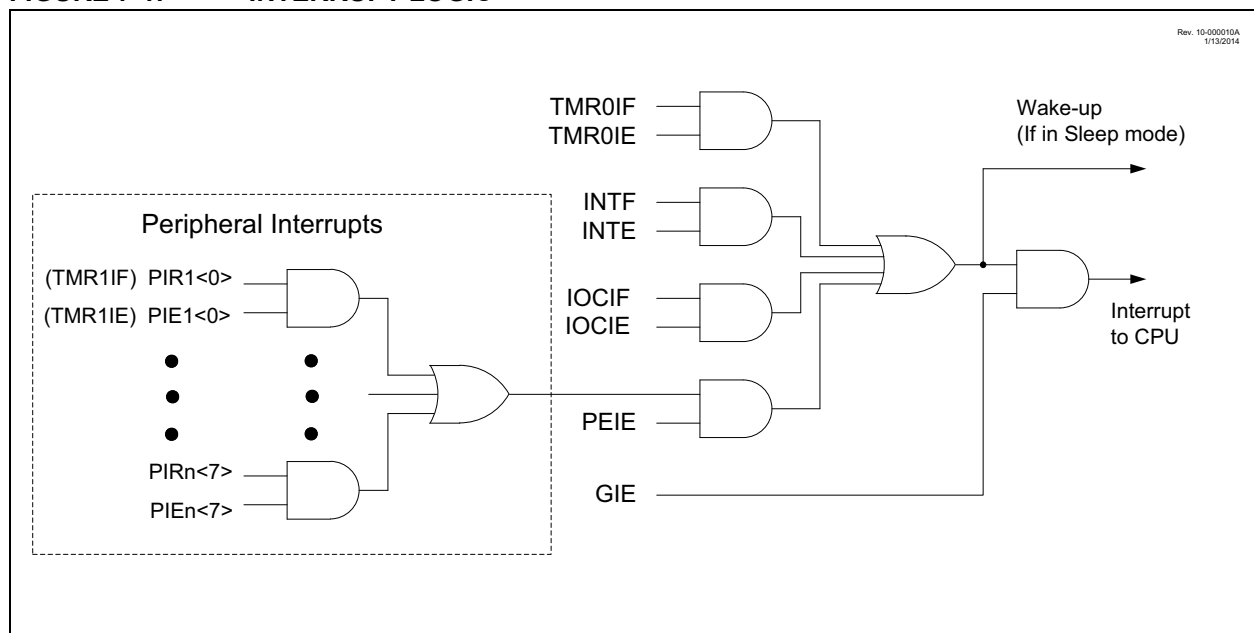
This chapter contains the following information for interrupts:

- Operation
- Interrupt Latency
- Interrupts during Sleep
- INT Pin
- Automatic Context Saving

Many peripherals produce interrupts. Refer to the corresponding chapters for details.

A block diagram of the interrupt logic is shown in [Figure 7-1](#).

**FIGURE 7-1: INTERRUPT LOGIC**





## 7.1 Operation

Interrupts are disabled upon any device Reset. They are enabled by setting the following bits:

- GIE bit of the INTCON register
- Interrupt enable bit(s) for the specific interrupt event(s)
- PEIE bit of the INTCON register (if the interrupt enable bit of the interrupt event is contained in the PIE1 or PIE2 register)

The INTCON, PIR1 and PIR2 registers record individual interrupts via interrupt flag bits. Interrupt flag bits will be set, regardless of the status of the GIE, PEIE and individual interrupt enable bits.

The following events happen when an interrupt event occurs while the GIE bit is set:

- Current prefetched instruction is flushed
- GIE bit is cleared
- Current Program Counter (PC) is pushed onto the stack
- Critical registers are automatically saved to the shadow registers (see “[Section 7.5 “Automatic Context Saving”](#)”)
- PC is loaded with the interrupt vector, 0004h

The firmware within the Interrupt Service Routine (ISR) should determine the source of the interrupt by polling the interrupt flag bits. The interrupt flag bits must be cleared before exiting the ISR to avoid repeated interrupts. Because the GIE bit is cleared, any interrupt that occurs while executing the ISR will be recorded through its interrupt flag, but will not cause the processor to redirect to the interrupt vector.

The `RETFIE` instruction exits the ISR by popping the previous address from the stack, restoring the saved context from the shadow registers and setting the GIE bit.

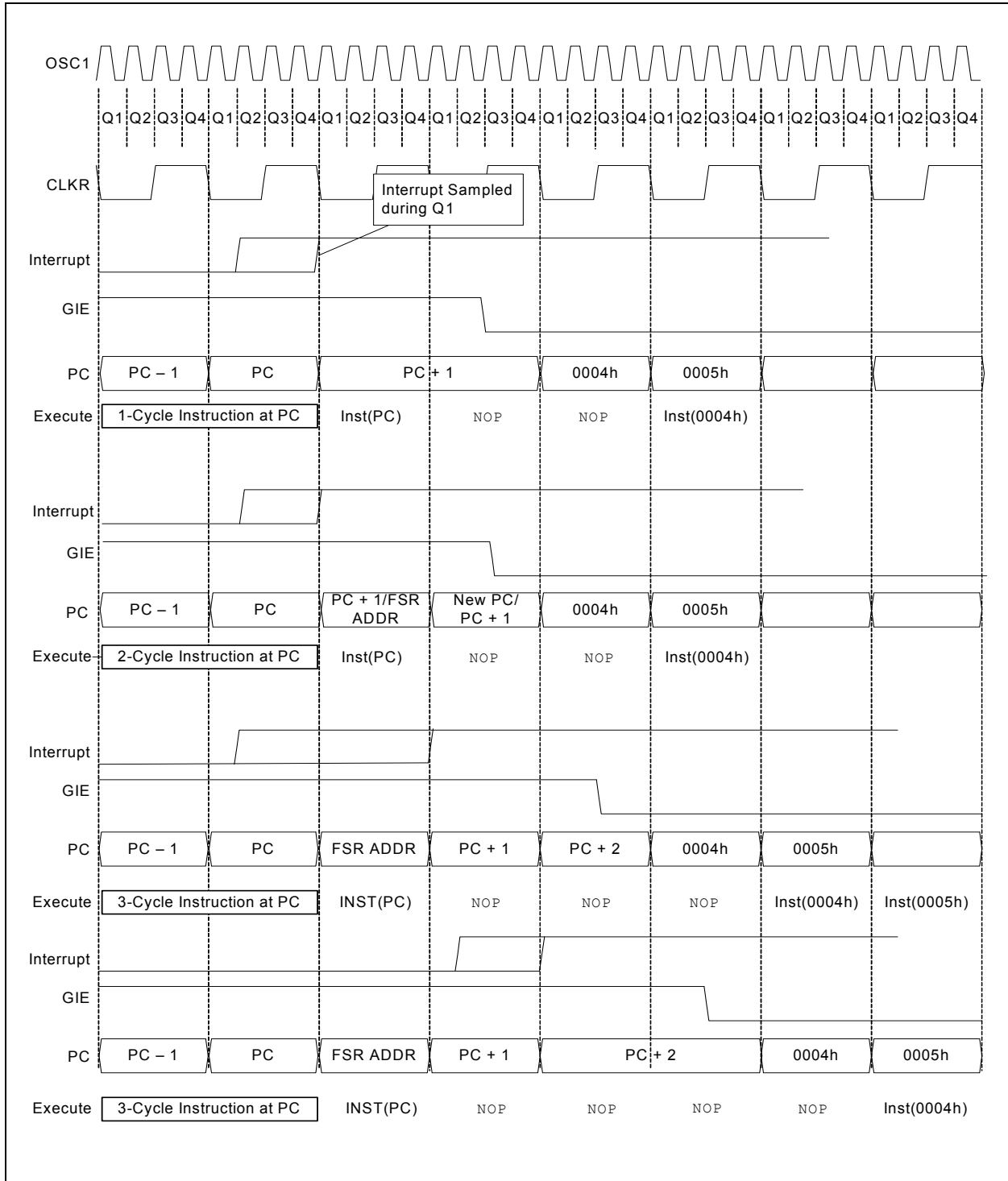
For additional information on a specific interrupt's operation, refer to its peripheral chapter.

- |  |
|--|
| <p><b>Note 1:</b> Individual interrupt flag bits are set, regardless of the state of any other enable bits.</p> <p><b>2:</b> All interrupts will be ignored while the GIE bit is cleared. Any interrupt occurring while the GIE bit is clear will be serviced when the GIE bit is set again.</p> |
|--|

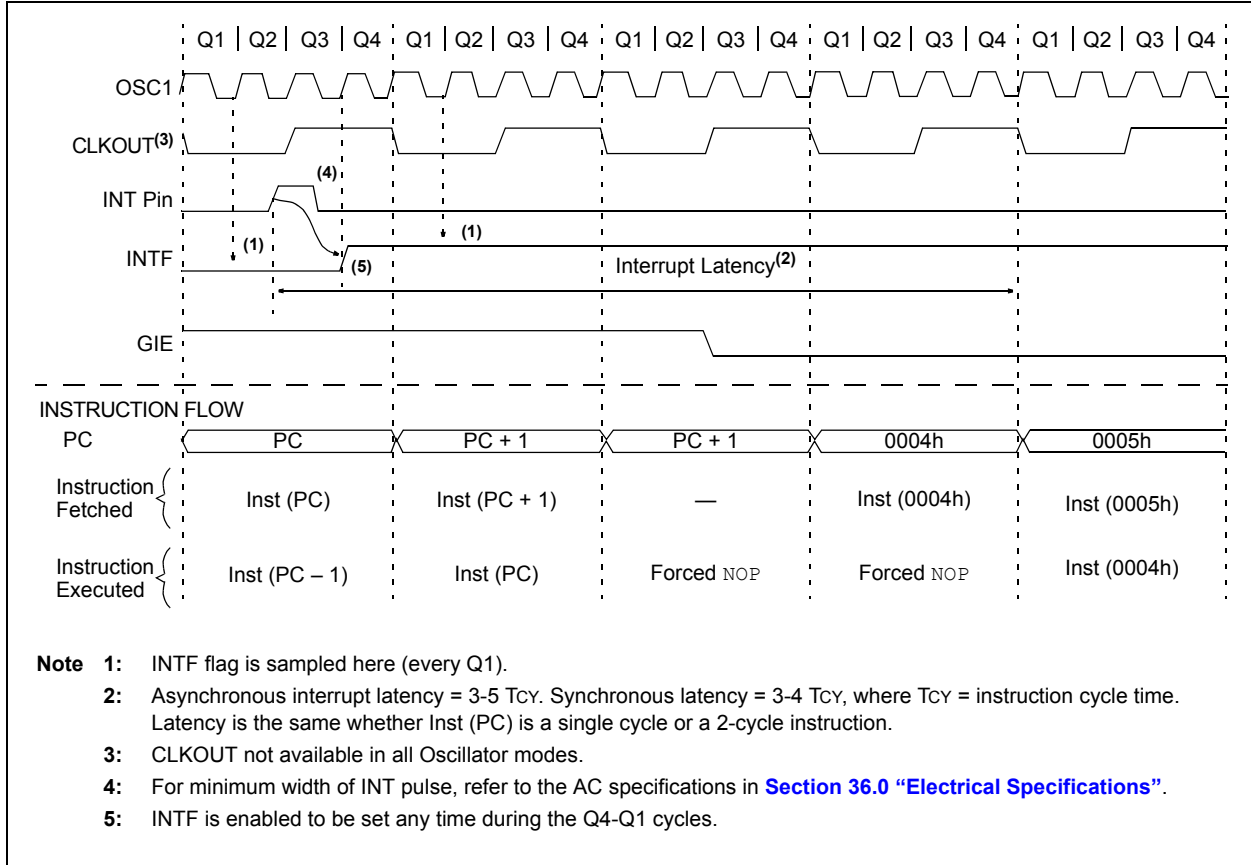
## 7.2 Interrupt Latency

Interrupt latency is defined as the time from when the interrupt event occurs to the time code execution at the interrupt vector begins. The latency for synchronous interrupts is three or four instruction cycles. For asynchronous interrupts, the latency is three to five instruction cycles, depending on when the interrupt occurs. See [Figure 7-2](#) and [Figure 7-3](#) for more details.

**FIGURE 7-2: INTERRUPT LATENCY**



**FIGURE 7-3: INT PIN INTERRUPT TIMING**



## 7.3 Interrupts During Sleep

Some interrupts can be used to wake from Sleep. To wake from Sleep, the peripheral must be able to operate without the system clock. The interrupt source must have the appropriate interrupt enable bit(s) set prior to entering Sleep.

On waking from Sleep, if the GIE bit is also set, the processor will branch to the interrupt vector. Otherwise, the processor will continue executing instructions after the `SLEEP` instruction. The instruction directly after the `SLEEP` instruction will always be executed before branching to the ISR. Refer to **Section 8.0 “Power-Down Mode (Sleep)”** for more details.

## 7.4 INT Pin

The INT pin can be used to generate an asynchronous edge-triggered interrupt. This interrupt is enabled by setting the INTE bit of the INTCON register. The INTEDG bit of the OPTION\_REG register determines on which edge the interrupt will occur. When the INTEDG bit is set, the rising edge will cause the interrupt. When the INTEDG bit is clear, the falling edge will cause the interrupt. The INTF bit of the INTCON register will be set when a valid edge appears on the INT pin. If the GIE and INTE bits are also set, the processor will redirect program execution to the interrupt vector.

## 7.5 Automatic Context Saving

Upon entering an interrupt, the return PC address is saved on the stack. Additionally, the following registers are automatically saved in the shadow registers:

- W register
- STATUS register (except for  $\overline{TO}$  and  $\overline{PD}$ )
- BSR register
- FSR registers
- PCLATH register

Upon exiting the Interrupt Service Routine, these registers are automatically restored. Any modifications to these registers during the ISR will be lost. If modifications to any of these registers are desired, the corresponding shadow register should be modified and the value will be restored when exiting the ISR. The shadow registers are available in Bank 31 and are readable and writable. Depending on the user's application, other registers may also need to be saved.

## 7.6 Register Definitions: Interrupt Control

### REGISTER 7-1: INTCON: INTERRUPT CONTROL REGISTER

R/W-0/0	R/W-0/0	R/W-0/0	R/W-0/0	R/W-0/0	R/W-0/0	R/W-0/0	R-0/0
GIE	PEIE	TMR0IE	INTE	IOCIE	TMR0IF	INTF	IOCIF <sup>(1)</sup>
bit 7							bit 0

#### Legend:

R = Readable bit

W = Writable bit

u = Bit is unchanged

x = Bit is unknown

U = Unimplemented bit, read as '0'

'1' = Bit is set

'0' = Bit is cleared

-n/n = Value at POR and BOR/Value at all other Resets

- bit 7      **GIE:** Global Interrupt Enable bit  
           1 = Enables all active interrupts  
           0 = Disables all interrupts
- bit 6      **PEIE:** Peripheral Interrupt Enable bit  
           1 = Enables all active peripheral interrupts  
           0 = Disables all peripheral interrupts
- bit 5      **TMR0IE:** Timer0 Overflow Interrupt Enable bit  
           1 = Enables the Timer0 interrupt  
           0 = Disables the Timer0 interrupt
- bit 4      **INTE:** INT External Interrupt Enable bit  
           1 = Enables the INT external interrupt  
           0 = Disables the INT external interrupt
- bit 3      **IOCIE:** Interrupt-On-Change Enable bit  
           1 = Enables the Interrupt-On-Change  
           0 = Disables the Interrupt-On-Change
- bit 2      **TMR0IF:** Timer0 Overflow Interrupt Flag bit  
           1 = TMR0 register has overflowed  
           0 = TMR0 register did not overflow
- bit 1      **INTF:** INT External Interrupt Flag bit  
           1 = The INT external interrupt occurred  
           0 = The INT external interrupt did not occur
- bit 0      **IOCIF:** Interrupt-On-Change Interrupt Flag bit<sup>(1)</sup>  
           1 = When at least one of the Interrupt-On-Change pins changed state  
           0 = None of the Interrupt-On-Change pins have changed state

**Note 1:** The IOCIF Flag bit is read-only and cleared when all the Interrupt-On-Change flags in the IOCxF registers have been cleared by software.

**Note:** Interrupt flag bits are set when an interrupt condition occurs, regardless of the state of its corresponding enable bit or the Global Enable bit, GIE, of the INTCON register. User software should ensure the appropriate interrupt flag bits are clear prior to enabling an interrupt.

# PIC16(L)F1764/5/8/9

## REGISTER 7-2: PIE1: PERIPHERAL INTERRUPT ENABLE REGISTER 1

R/W-0/0	R/W-0/0	R/W-0/0	R/W-0/0	R/W-0/0	R/W-0/0	R/W-0/0	R/W-0/0
TMR1GIE	ADIE	RCIE	TXIE	SSP1IE	CCP1IE	TMR2IE	TMR1IE
bit 7							bit 0

### Legend:

R = Readable bit

W = Writable bit

u = Bit is unchanged

x = Bit is unknown

U = Unimplemented bit, read as '0'

'1' = Bit is set

'0' = Bit is cleared

-n/n = Value at POR and BOR/Value at all other Resets

- bit 7      **TMR1GIE:** Timer1 Gate Interrupt Enable bit  
 1 = Enables the Timer1 gate acquisition interrupt  
 0 = Disables the Timer1 gate acquisition interrupt
- bit 6      **ADIE:** Analog-to-Digital Converter (ADC) Interrupt Enable bit  
 1 = Enables the ADC interrupt  
 0 = Disables the ADC interrupt
- bit 5      **RCIE:** EUSART Receive Interrupt Enable bit  
 1 = Enables the EUSART receive interrupt  
 0 = Disables the EUSART receive interrupt
- bit 4      **TXIE:** EUSART Transmit Interrupt Enable bit  
 1 = Enables the EUSART transmit interrupt  
 0 = Disables the EUSART transmit interrupt
- bit 3      **SSP1IE:** Master Synchronous Serial Port (MSSP) Interrupt Enable bit  
 1 = Enables the MSSP interrupt  
 0 = Disables the MSSP interrupt
- bit 2      **CCP1IE:** CCP1 Interrupt Enable bit  
 1 = Enables the CCP1 interrupt  
 0 = Disables the CCP1 interrupt
- bit 1      **TMR2IE:** TMR2 to T2PR Match Interrupt Enable bit  
 1 = Enables the Timer2 to T2PR match interrupt  
 0 = Disables the Timer2 to T2PR match interrupt
- bit 0      **TMR1IE:** Timer1 Overflow Interrupt Enable bit  
 1 = Enables the Timer1 overflow interrupt  
 0 = Disables the Timer1 overflow interrupt

**Note:** Bit PEIE of the INTCON register must be set to enable any peripheral interrupt.

# PIC16(L)F1764/5/8/9

## REGISTER 7-3: PIE2: PERIPHERAL INTERRUPT ENABLE REGISTER 2

R/W-0/0	R/W-0/0	R/W-0/0	U-0	R/W-0/0	R/W-0/0	R/W-0/0	R/W-0/0
OSFIE	C2IE	C1IE	—	BCL1IE	C4IE <sup>(1)</sup>	C3IE <sup>(1)</sup>	CCP2IE <sup>(1)</sup>
bit 7							bit 0

### Legend:

R = Readable bit

W = Writable bit

u = Bit is unchanged

x = Bit is unknown

U = Unimplemented bit, read as '0'

'1' = Bit is set

'0' = Bit is cleared

-n/n = Value at POR and BOR/Value at all other Resets

- bit 7      **OSFIE:** Oscillator Fail Interrupt Enable bit  
 1 = Enables the Oscillator fail interrupt  
 0 = Disables the Oscillator fail interrupt
- bit 6      **C2IE:** Comparator C2 Interrupt Enable bit  
 1 = Enables the Comparator C2 interrupt  
 0 = Disables the Comparator C2 interrupt
- bit 5      **C1IE:** Comparator C1 Interrupt Enable bit  
 1 = Enables the Comparator C1 interrupt  
 0 = Disables the Comparator C1 interrupt
- bit 4      **Unimplemented:** Read as '0'
- bit 3      **BCL1IE:** MSSP Bus Collision Interrupt Enable bit  
 1 = Enables the MSSP bus collision interrupt  
 0 = Disables the MSSP bus collision interrupt
- bit 2      **C4IE:** Comparator C4 Interrupt Enable bit<sup>(1)</sup>  
 1 = Enables the Comparator C4 interrupt  
 0 = Disables the Comparator C4 interrupt
- bit 1      **C3IE:** Comparator C3 Interrupt Enable bit<sup>(1)</sup>  
 1 = Enables the Comparator C3 interrupt  
 0 = Disables the Comparator C3 interrupt
- bit 0      **CCP2IE:** CCP2 Interrupt Enable bit<sup>(1)</sup>  
 1 = Enables the CCP2 interrupt  
 0 = Disables the CCP2 interrupt

**Note 1:** PIC16(L)F1768/9 only.

**Note:** Bit PEIE of the INTCON register must be set to enable any peripheral interrupt.

# PIC16(L)F1764/5/8/9

## REGISTER 7-4: PIE3: PERIPHERAL INTERRUPT ENABLE REGISTER 3

R/W-0/0	R/W-0/0	R/W-0/0	R/W-0/0	R/W-0/0	R/W-0/0	R/W-0/0	R/W-0/0
PWM6IE <sup>(1)</sup>	PWM5IE	COG1IE	ZCDIE	COG2IE <sup>(1)</sup>	CLC3IE	CLC2IE	CLC1IE
bit 7							bit 0

### Legend:

R = Readable bit

W = Writable bit

u = Bit is unchanged

x = Bit is unknown

U = Unimplemented bit, read as '0'

'1' = Bit is set

'0' = Bit is cleared

-n/n = Value at POR and BOR/Value at all other Resets

- bit 7      **PWM6IE:** PWM6 Interrupt Enable bit<sup>(1)</sup>  
           1 = PWM6 interrupt is enabled  
           0 = PWM6 interrupt is disabled
- bit 6      **PWM5IE:** PWM5 Interrupt Enable bit  
           1 = PWM5 interrupt is enabled  
           0 = PWM5 interrupt is disabled
- bit 5      **COG1IE:** COG1 Auto-Shutdown Interrupt Enable bit  
           1 = COG1 interrupt is enabled  
           0 = COG1 interrupt is disabled
- bit 4      **ZCDIE:** Zero-Cross Detection Interrupt Enable bit  
           1 = ZCD interrupt is enabled  
           0 = ZCD interrupt is disabled
- bit 3      **COG2IE:** COG2 Auto-Shutdown Interrupt Enable bit<sup>(1)</sup>  
           1 = COG2 interrupt is enabled  
           0 = COG2 interrupt is disabled
- bit 2      **CLC3IE:** CLC3 Interrupt Enable bit  
           1 = CLC3 interrupt is enabled  
           0 = CLC3 interrupt is disabled
- bit 1      **CLC2IE:** CLC2 Interrupt Enable bit  
           1 = CLC2 interrupt is enabled  
           0 = CLC2 interrupt is disabled
- bit 0      **CLC1IE:** CLC1 Interrupt Enable bit  
           1 = CLC1 interrupt is enabled  
           0 = CLC1 interrupt is disabled

**Note 1:** PIC16(L)F1768/9 only.

**Note:** Bit PEIE of the INTCON register must be set to enable any peripheral interrupt.



## REGISTER 7-5: PIE4: PERIPHERAL INTERRUPT ENABLE REGISTER 4

U-0	U-0	R/W-0/0	R/W-0/0	R/W-0/0	R/W-0/0	R/W-0/0	R/W-0/0
—	—	TMR5GIE	TMR5IE	TMR3GIE	TMR3IE	TMR6IE	TRM4IE
bit 7							bit 0

### Legend:

R = Readable bit	W = Writable bit	U = Unimplemented bit, read as '0'
u = Bit is unchanged	x = Bit is unknown	-n/n = Value at POR and BOR/Value at all other Resets
'1' = Bit is set	'0' = Bit is cleared	

- bit 7-6      **Unimplemented:** Read as '0'
- bit 5      **TMR5GIE:** Timer5 Gate Interrupt Enable bit  
 1 = Enables the Timer5 gate acquisition interrupt  
 0 = Disables the Timer5 gate acquisition interrupt
- bit 4      **TMR5IE:** TMR5 to Overflow Interrupt Enable bit  
 1 = Enables the Timer5 to T5PR match interrupt  
 0 = Disables the Timer5 to T5PR match interrupt
- bit 3      **TMR3GIE:** Timer3 Gate Interrupt Enable bit  
 1 = Enables the Timer3 gate acquisition interrupt  
 0 = Disables the Timer3 gate acquisition interrupt
- bit 2      **TMR3IE:** TMR3 to Overflow Interrupt Enable bit  
 1 = Enables the Timer3 to T3PR match interrupt  
 0 = Disables the Timer3 to T3PR match interrupt
- bit 1      **TMR6IE:** TMR6 to T6PR Match Interrupt Enable bit  
 1 = Enables the Timer6 to T6PR match interrupt  
 0 = Disables the Timer6 to T6PR match interrupt
- bit 0      **TMR4IE:** TMR4 to T4PR Match Interrupt Enable bit  
 1 = Enables the Timer4 to T4PR match interrupt  
 0 = Disables the Timer4 to T4PR match interrupt

# PIC16(L)F1764/5/8/9

## REGISTER 7-6: PIR1: PERIPHERAL INTERRUPT REQUEST REGISTER 1

R/W-0/0	R/W-0/0	R-0/0	R-0/0	R/W-0/0	R/W-0/0	R/W-0/0	R/W-0/0
TMR1GIF	ADIF	RCIF	TXIF	SSP1IF	CCP1IF	TMR2IF	TMR1IF
bit 7							bit 0

### Legend:

R = Readable bit

W = Writable bit

u = Bit is unchanged

x = Bit is unknown

U = Unimplemented bit, read as '0'

'1' = Bit is set

'0' = Bit is cleared

-n/n = Value at POR and BOR/Value at all other Resets

- bit 7      **TMR1GIF:** Timer1 Gate Interrupt Flag bit  
1 = Interrupt is pending  
0 = Interrupt is not pending
- bit 6      **ADIF:** Analog-to-Digital Converter (ADC) Interrupt Flag bit  
1 = Interrupt is pending  
0 = Interrupt is not pending
- bit 5      **RCIF:** EUSART Receive Interrupt Flag bit  
1 = Interrupt is pending  
0 = Interrupt is not pending
- bit 4      **TXIF:** EUSART Transmit Interrupt Flag bit  
1 = Interrupt is pending  
0 = Interrupt is not pending
- bit 3      **SSP1IF:** Master Synchronous Serial Port (MSSP) Interrupt Flag bit  
1 = Interrupt is pending  
0 = Interrupt is not pending
- bit 2      **CCP1IF:** CCP1 Interrupt Flag bit  
1 = Interrupt is pending  
0 = Interrupt is not pending
- bit 1      **TMR2IF:** Timer2 to T2PR Interrupt Flag bit  
1 = Interrupt is pending  
0 = Interrupt is not pending
- bit 0      **TMR1IF:** Timer1 Overflow Interrupt Flag bit  
1 = Interrupt is pending  
0 = Interrupt is not pending

**Note:** Interrupt flag bits are set when an interrupt condition occurs, regardless of the state of its corresponding enable bit or the Global Enable bit, GIE, of the INTCON register. User software should ensure the appropriate interrupt flag bits are clear prior to enabling an interrupt.

# PIC16(L)F1764/5/8/9

## REGISTER 7-7: PIR2: PERIPHERAL INTERRUPT REQUEST REGISTER 2

R/W-0/0	R/W-0/0	R/W-0/0	U-0	R/W-0/0	R/W-0/0	R/W-0/0	R/W-0/0
OSFIF	C2IF	C1IF	—	BCL1IF	C4IF <sup>(1)</sup>	C3IF <sup>(1)</sup>	CCP2IF <sup>(1)</sup>
bit 7							bit 0

### Legend:

R = Readable bit

W = Writable bit

u = Bit is unchanged

x = Bit is unknown

U = Unimplemented bit, read as '0'

'1' = Bit is set

'0' = Bit is cleared

-n/n = Value at POR and BOR/Value at all other Resets

bit 7	<b>OSFIF:</b> Oscillator Fail Interrupt Flag bit 1 = Interrupt is pending 0 = Interrupt is not pending
bit 6	<b>C2IF:</b> Comparator C2 Interrupt Flag bit 1 = Interrupt is pending 0 = Interrupt is not pending
bit 5	<b>C1IF:</b> Comparator C1 Interrupt Flag bit 1 = Interrupt is pending 0 = Interrupt is not pending
bit 4	<b>Unimplemented:</b> Read as '0'
bit 3	<b>BCL1IF:</b> MSSP Bus Collision Interrupt Flag bit 1 = Interrupt is pending 0 = Interrupt is not pending
bit 2	<b>C4IF:</b> Comparator C4 Interrupt Flag bit <sup>(1)</sup> 1 = Interrupt is pending 0 = Interrupt is not pending
bit 1	<b>C3IF:</b> Comparator C3 Interrupt Flag bit <sup>(1)</sup> 1 = Interrupt is pending 0 = Interrupt is not pending
bit 0	<b>CCP2IF:</b> CCP2 Interrupt Flag bit <sup>(1)</sup> 1 = Interrupt is pending 0 = Interrupt is not pending

**Note 1:** PIC16(L)F1768/9 only.

**Note:** Interrupt flag bits are set when an interrupt condition occurs, regardless of the state of its corresponding enable bit or the Global Enable bit, GIE, of the INTCON register. User software should ensure the appropriate interrupt flag bits are clear prior to enabling an interrupt.

# PIC16(L)F1764/5/8/9

## REGISTER 7-8: PIR3: PERIPHERAL INTERRUPT REQUEST REGISTER 3

R/W-0/0	R/W-0/0	R/W-0/0	R/W-0/0	R/W-0/0	R/W-0/0	R/W-0/0	R/W-0/0
PWM6IF <sup>(1)</sup>	PWM5IF	COG1IF	ZCDIF	COG2IF <sup>(1)</sup>	CLC3IF	CLC2IF	CLC1IF
bit 7							bit 0

### Legend:

R = Readable bit

W = Writable bit

u = Bit is unchanged

x = Bit is unknown

U = Unimplemented bit, read as '0'

'1' = Bit is set

'0' = Bit is cleared

-n/n = Value at POR and BOR/Value at all other Resets

- bit 7      **PWM6IF:** PWM6 Interrupt Flag bit<sup>(1)</sup>  
             1 = Interrupt is pending  
             0 = Interrupt is not pending
- bit 6      **PWM5IF:** PWM5 Interrupt Flag bit  
             1 = Interrupt is pending  
             0 = Interrupt is not pending
- bit 5      **COG1IF:** COG1 Auto-Shutdown Interrupt Flag bit  
             1 = Interrupt is pending  
             0 = Interrupt is not pending
- bit 4      **ZCDIF:** Zero-Cross Detection Interrupt Flag bit  
             1 = Interrupt is pending  
             0 = Interrupt is not pending
- bit 3      **COG2IF:** COG2 Auto-Shutdown Interrupt Flag bit<sup>(1)</sup>  
             1 = Interrupt is pending  
             0 = Interrupt is not pending
- bit 2      **CLC3IF:** CLC3 Interrupt Flag bit  
             1 = Interrupt is pending  
             0 = Interrupt is not pending
- bit 1      **CLC2IF:** CLC2 Interrupt Flag bit  
             1 = Interrupt is pending  
             0 = Interrupt is not pending
- bit 0      **CLC1IF:** CLC1 Interrupt Flag bit  
             1 = Interrupt is pending  
             0 = Interrupt is not pending

**Note 1:** PIC16(L)F1768/9 only.

**Note:** Interrupt flag bits are set when an interrupt condition occurs, regardless of the state of its corresponding enable bit or the Global Enable bit, GIE, of the INTCON register. User software should ensure the appropriate interrupt flag bits are clear prior to enabling an interrupt.

## REGISTER 7-9: PIR4: PERIPHERAL INTERRUPT REQUEST REGISTER 4

U-0	U-0	R/W-0/0	R/W-0/0	R/W-0/0	R/W-0/0	R/W-0/0	R/W-0/0
—	—	TMR5GIF	TMR5IF	TMR3GIF	TMR3IF	TMR6IF	TMR4IF
bit 7							bit 0

### Legend:

R = Readable bit	W = Writable bit	U = Unimplemented bit, read as '0'
u = Bit is unchanged	x = Bit is unknown	-n/n = Value at POR and BOR/Value at all other Resets
'1' = Bit is set	'0' = Bit is cleared	

- bit 7-6      **Unimplemented:** Read as '0'
- bit 5      **TMR5GIF:** Timer5 Gate Interrupt Flag bit
  - 1 = Interrupt is pending
  - 0 = Interrupt is not pending
- bit 4      **TMR5IF:** TMR5 to Overflow Interrupt Flag bit
  - 1 = Interrupt is pending
  - 0 = Interrupt is not pending
- bit 3      **TMR3GIF:** Timer3 Gate Interrupt Flag bit
  - 1 = Interrupt is pending
  - 0 = Interrupt is not pending
- bit 2      **TMR3IF:** TMR3 to Overflow Interrupt Flag bit
  - 1 = Interrupt is pending
  - 0 = Interrupt is not pending
- bit 1      **TMR6IF:** TMR6 to T6PR Match Interrupt Flag bit
  - 1 = Interrupt is pending
  - 0 = Interrupt is not pending
- bit 0      **TMR4IF:** TMR4 to T4PR Match Interrupt Flag bit
  - 1 = Interrupt is pending
  - 0 = Interrupt is not pending

# PIC16(L)F1764/5/8/9

**TABLE 7-1: SUMMARY OF REGISTERS ASSOCIATED WITH INTERRUPTS**

Name	Bit 7	Bit 6	Bit 5	Bit 4	Bit 3	Bit 2	Bit 1	Bit 0	Register on Page
INTCON	GIE	PEIE	TMR0IE	INTE	IOCFIE	TMR0IF	INTF	IOCF	101
OPTION_REG	$\overline{\text{WPUEN}}$	INTEDG	TMR0CS	TMR0SE	PSA	PS<2:0>			216
PIE1	TMR1GIE	ADIE	RCIE	TXIE	SSP1IE	CCP1IE	TMR2IE	TMR1IE	102
PIE2	OSFIE	C2IE	C1IE	—	BCL1IE	C4IE <sup>(1)</sup>	C3IE <sup>(1)</sup>	CCP2IE <sup>(1)</sup>	103
PIE3	PWM6IE <sup>(1)</sup>	PWM5IE	COG1IE	ZCDIE	COG2IE <sup>(1)</sup>	CLC3IE	CLC2IE	CLC1IE	104
PIE4	—	—	TMR5GIE	TMR5IE	TMR3GIE	TMR3IE	TMR6IE	TRM4IE	105
PIR1	TMR1GIF	ADIF	RCIF	TXIF	SSP1IF	CCP1IF	TMR2IF	TMR1IF	106
PIR2	OSFIF	C2IF	C1IF	—	BCL1IF	C4IF <sup>(1)</sup>	C3IF <sup>(1)</sup>	CCP2IF <sup>(1)</sup>	107
PIR3	PWM6IF <sup>(1)</sup>	PWM5IF	COG1IF	ZCDIF	COG2IF <sup>(1)</sup>	CLC3IF	CLC2IF	CLC1IF	108
PIR4	—	—	TMR5GIF	TMR5IF	TMR3GIF	TMR3IF	TMR6IF	TRM4IF	109

**Legend:** — = unimplemented location, read as '0'. Shaded cells are not used by interrupts.

**Note 1:** PIC16(L)F1768/9 only.

## 8.0 POWER-DOWN MODE (SLEEP)

The Power-Down mode is entered by executing a `SLEEP` instruction.

Upon entering Sleep mode, the following conditions exist:

1. WDT will be cleared, but keeps running if enabled for operation during Sleep.
2.  $\overline{PD}$  bit of the STATUS register is cleared.
3.  $\overline{TO}$  bit of the STATUS register is set.
4. CPU clock is disabled.
5. 31 kHz LFINTOSC is unaffected and peripherals that operate from it may continue operation in Sleep.
6. Timer1 and peripherals that operate from Timer1 continue operation in Sleep when the Timer1 clock source selected is:
  - LFINTOSC
  - T1CKI
  - Secondary oscillator
7. ADC is unaffected if the dedicated FRC oscillator is selected.
8. I/O ports maintain the status they had before `SLEEP` was executed (driving high, low or high-impedance).
9. Resets other than WDT are not affected by Sleep mode.

Refer to individual chapters for more details on peripheral operation during Sleep.

To minimize current consumption, the following conditions should be considered:

- I/O pins should not be floating
- External circuitry sinking current from I/O pins
- Internal circuitry sourcing current from I/O pins
- Current draw from pins with internal weak pull-ups
- Modules using 31 kHz LFINTOSC
- Modules using secondary oscillator

I/O pins that are high-impedance inputs should be pulled to  $V_{DD}$  or  $V_{SS}$  externally to avoid switching currents caused by floating inputs.

Examples of internal circuitry that might be sourcing current include modules such as the DAC and FVR modules. See [Section 17.0 “5-Bit Digital-to-Analog Converter \(DAC\) Module”](#) and [Section 14.0 “Fixed Voltage Reference \(FVR\)”](#) for more information on these modules.

## 8.1 Wake-up from Sleep

The device can wake-up from Sleep through one of the following events:

1. External Reset input on  $\overline{MCLR}$  pin, if enabled.
2. Brown-out Reset (BOR), if enabled.
3. Power-on Reset (POR), if enabled.
4. Watchdog Timer, if enabled.
5. Any external interrupt.
6. Interrupts by peripherals capable of running during Sleep (see individual peripheral for more information).

The first three events will cause a device Reset. The last three events are considered a continuation of program execution. To determine whether a device Reset or wake-up event occurred, refer to [Section 6.12 “Determining the Cause of a Reset”](#).

When the `SLEEP` instruction is being executed, the next instruction ( $PC + 1$ ) is prefetched. For the device to wake-up through an interrupt event, the corresponding interrupt enable bit must be enabled. Wake-up will occur regardless of the state of the GIE bit. If the GIE bit is disabled, the device continues execution at the instruction after the `SLEEP` instruction. If the GIE bit is enabled, the device executes the instruction after the `SLEEP` instruction, the device will then call the Interrupt Service Routine. In cases where the execution of the instruction following `SLEEP` is not desirable, the user should insert a `NOP` after the `SLEEP` instruction.

The WDT is cleared when the device wakes up from Sleep, regardless of the source of wake-up.

## 8.1.1 WAKE-UP USING INTERRUPTS

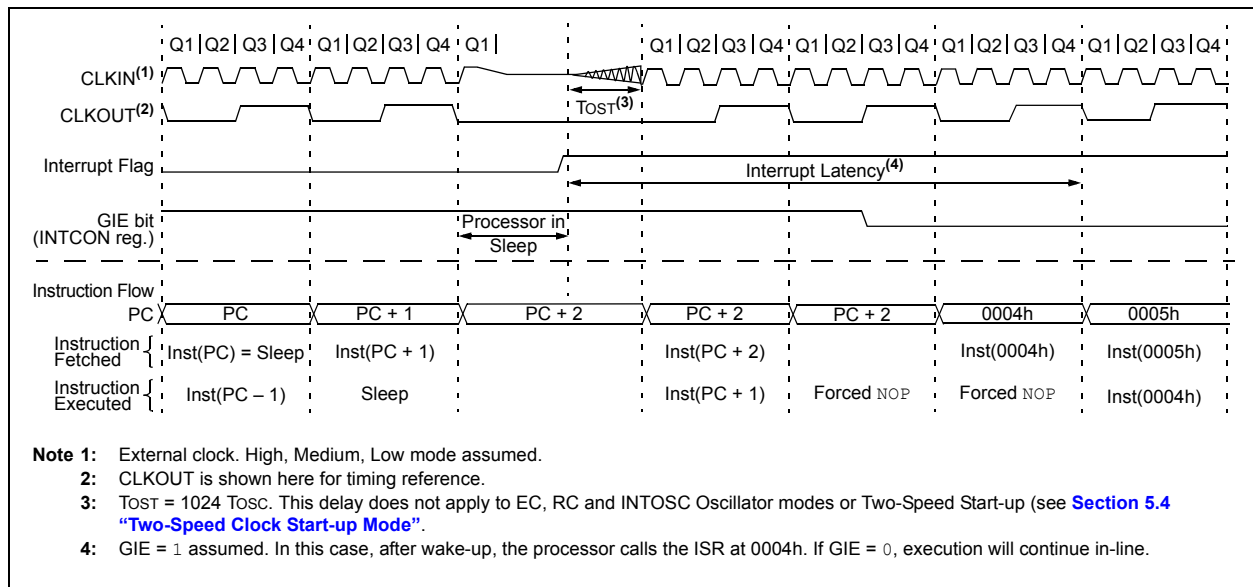
When global interrupts are disabled (GIE cleared) and any interrupt source has both its interrupt enable bit and interrupt flag bit set, one of the following will occur:

- If the interrupt occurs **before** the execution of a `SLEEP` instruction:
  - `SLEEP` instruction will execute as a `NOP`
  - `WDT` and `WDT` prescaler will not be cleared
  - $\overline{TO}$  bit of the `STATUS` register will not be set
  - $\overline{PD}$  bit of the `STATUS` register will not be cleared

- If the interrupt occurs **during or after** the execution of a `SLEEP` instruction:
  - `SLEEP` instruction will be completely executed
  - Device will immediately wake-up from Sleep
  - `WDT` and `WDT` prescaler will be cleared
  - $\overline{TO}$  bit of the `STATUS` register will be set
  - $\overline{PD}$  bit of the `STATUS` register will be cleared

Even if the flag bits were checked before executing a `SLEEP` instruction, it may be possible for flag bits to become set before the `SLEEP` instruction completes. To determine whether a `SLEEP` instruction executed, test the  $\overline{PD}$  bit. If the  $\overline{PD}$  bit is set, the `SLEEP` instruction was executed as a `NOP`.

**FIGURE 8-1: WAKE-UP FROM SLEEP THROUGH INTERRUPT**





## 8.2 Low-Power Sleep Mode

The PIC16F1764/5/8/9 devices contain an internal Low Dropout (LDO) voltage regulator, which allows the device I/O pins to operate at voltages up to 5.5V while the internal device logic operates at a lower voltage. The LDO and its associated reference circuitry must remain active when the device is in Sleep mode. The PIC16F1764/5/8/9 devices allow the user to optimize the operating current in Sleep, depending on the application requirements.

A Low-Power Sleep mode can be selected by setting the VREGPM bit of the VREGCON register. With this bit set, the LDO and reference circuitry are placed in a low-power state when the device is in Sleep.

### 8.2.1 SLEEP CURRENT VS. WAKE-UP TIME

In the default operating mode, the LDO and reference circuitry remain in the normal configuration while in Sleep. The device is able to exit Sleep mode quickly since all circuits remain active. In Low-Power Sleep mode, when waking up from Sleep, an extra delay time is required for these circuits to return to the normal configuration and stabilize.

The Low-Power Sleep mode is beneficial for applications that stay in Sleep mode for long periods of time. The Normal mode is beneficial for applications that need to wake from Sleep quickly and frequently.

### 8.2.2 PERIPHERAL USAGE IN SLEEP

Some peripherals that can operate in Sleep mode will not operate properly with the Low-Power Sleep mode selected. The Low-Power Sleep mode is intended for use with the following peripherals only:

- Brown-out Reset (BOR)
- Watchdog Timer (WDT)
- External interrupt pin/Interrupt-On-Change pins
- Timer1 (with external clock source < 100 kHz)

**Note:** The PIC16LF1764/5/8/9 devices do not have a configurable Low-Power Sleep mode. PIC16LF1764/5/8/9 devices are unregulated devices and are always in the lowest power state when in Sleep, with no wake-up time penalty. These devices have a lower maximum V<sub>DD</sub> and I/O voltage than the PIC16F1764/5/8/9. See [Section 36.0 “Electrical Specifications”](#) for more information.

## 8.3 Register Definitions: Voltage Regulator Control

### REGISTER 8-1: VREGCON: VOLTAGE REGULATOR CONTROL REGISTER<sup>(1)</sup>

U-0	U-0	U-0	U-0	U-0	U-0	R/W-0/0	R/W-1/1
—	—	—	—	—	—	VREGPM	r
bit 7							bit 0

#### Legend:

R = Readable bit	W = Writable bit	r = Reserved bit
u = Bit is unchanged	x = Bit is unknown	U = Unimplemented bit, read as '0'
'1' = Bit is set	'0' = Bit is cleared	-n/n = Value at POR and BOR/Value at all other Resets

bit 7-2 **Unimplemented:** Read as '0'

bit 1 **VREGPM:** Voltage Regulator Power Mode Selection bit

1 = Low-Power Sleep mode is enabled in Sleep<sup>(2)</sup>  
Draws lowest current in Sleep, slower wake-up.

0 = Normal Power mode is enabled in Sleep<sup>(2)</sup>  
Draws higher current in Sleep, faster wake-up.

bit 0 **Reserved:** Read as '1'. Maintain this bit set.

**Note 1:** PIC16F1764/5/8/9 only.

**2:** See [Section 36.0 “Electrical Specifications”](#).

**TABLE 8-1: SUMMARY OF REGISTERS ASSOCIATED WITH POWER-DOWN MODE**

Name	Bit 7	Bit 6	Bit 5	Bit 4	Bit 3	Bit 2	Bit 1	Bit 0	Register on Page	
INTCON	GIE	PEIE	TMR0IE	INTE	IOCIE	TMR0IF	INTF	IOCIF	101	
IOCAP	—	—	IOCAP<5:0>						164	
IOCAN	—	—	IOCAN<5:0>						164	
IOCAF	—	—	IOCAF<5:0>						165	
IOCBP <sup>(1)</sup>	IOCBP<7:4>				—	—	—	—	165	
IOCBN <sup>(1)</sup>	IOCBN<7:4>				—	—	—	—	166	
IOCBF <sup>(1)</sup>	IOCBF<7:4>				—	—	—	—	166	
IOCCP	IOCCP<7:6> <sup>(1)</sup>		IOCCP<5:0>						167	
IOCCN	IOCCN<7:6> <sup>(1)</sup>		IOCCN<5:0>						167	
IOCCF	IOCCF<7:6> <sup>(1)</sup>		IOCCF<5:0>						168	
PIE1	TMR1GIE	ADIE	RCIE	TXIE	SSP1IE	CCP1IE	TMR2IE	TMR1IE	102	
PIE2	OSFIE	C2IE	C1IE	—	BCL1IE	C4IE <sup>(1)</sup>	C3IE <sup>(1)</sup>	CCP2IE <sup>(1)</sup>	103	
PIE3	PWM6IE <sup>(1)</sup>	PWM5IE	COG1IE	ZCDIE	COG2IE <sup>(1)</sup>	CLC3IE	CLC2IE	CLC1IE	104	
PIE4	—	—	TMR5GIE	TMR5IE	TMR3GIE	TMR3IE	TMR6IE	TRM4IE	105	
PIR1	TMR1GIF	ADIF	RCIF	TXIF	SSP1IF	CCP1IF	TMR2IF	TMR1IF	106	
PIR2	OSFIF	C2IF	C1IF	—	BCL1IF	C4IF <sup>(1)</sup>	C3IF <sup>(1)</sup>	CCP2IF <sup>(1)</sup>	107	
PIR3	PWM6IF <sup>(1)</sup>	PWM5IF	COG1IF	ZCDIF	COG2IF <sup>(1)</sup>	CLC3IF	CLC2IF	CLC1IF	108	
PIR4	—	—	TMR5GIF	TMR5IF	TMR3GIF	TMR3IF	TMR6IF	TRM4IF	109	
STATUS	—	—	—	$\overline{TO}$	$\overline{PD}$	Z	DC	C	27	
VREGCON <sup>(2)</sup>	—	—	—	—	—	—	VREGPM	r	114	
WDTCON	—	—	WDTPS<4:0>						SWDTEN	117

**Legend:** — = unimplemented location, read as '0'; r = Reserved bit. Shaded cells are not used in Power-Down mode.

**Note 1:** PIC16(L)F1768/9 only.

**2:** PIC16F1764/5/8/9 only.

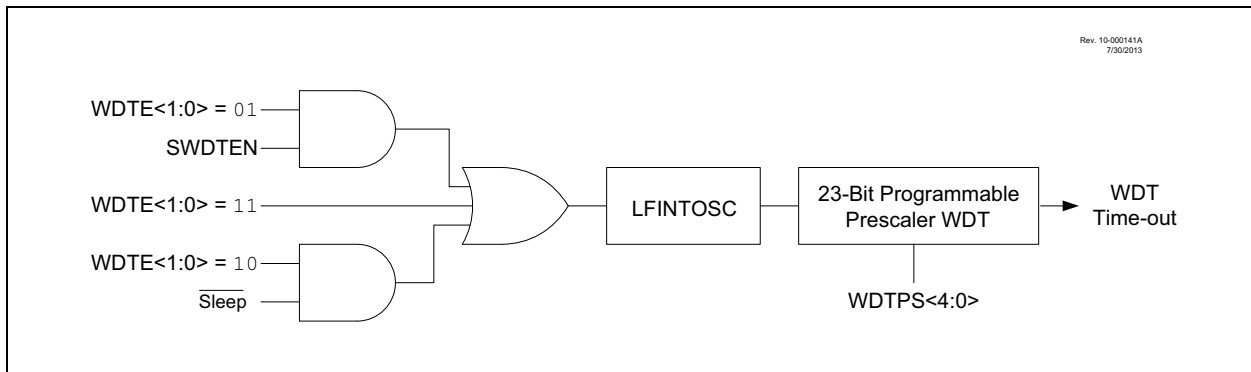
## 9.0 WATCHDOG TIMER (WDT)

The Watchdog Timer is a system timer that generates a Reset if the firmware does not issue a `CLRWDT` instruction within the time-out period. The Watchdog Timer is typically used to recover the system from unexpected events.

The WDT has the following features:

- Independent clock source
- Multiple operating modes:
  - WDT is always on
  - WDT is off when in Sleep
  - WDT is controlled by software
  - WDT is always off
- Configurable time-out period is from 1 ms to 256 seconds (nominal)
- Multiple Reset conditions
- Operation during Sleep

**FIGURE 9-1: WATCHDOG TIMER BLOCK DIAGRAM**



## 9.1 Independent Clock Source

The WDT derives its time base from the 31 kHz LFINTOSC internal oscillator. Time intervals in this chapter are based on a nominal interval of 1 ms. See [Table 36-8](#) for the LFINTOSC specification.

## 9.2 WDT Operating Modes

The Watchdog Timer module has four operating modes controlled by the WDTE<1:0> bits in the Configuration Words (see [Table 9-1](#)).

### 9.2.1 WDT IS ALWAYS ON

When the WDTE<1:0> bits of the Configuration Words are set to '11', the WDT is always on.

WDT protection is active during Sleep.

### 9.2.2 WDT IS OFF IN SLEEP

When the WDTE<1:0> bits of the Configuration Words are set to '10', the WDT is on, except in Sleep.

WDT protection is not active during Sleep.

### 9.2.3 WDT CONTROLLED BY SOFTWARE

When the WDTE<1:0> bits of the Configuration Words are set to '01', the WDT is controlled by the SWDTEN bit of the WDTCON register.

WDT protection is unchanged by Sleep. See [Table 9-1](#) for more details.

**TABLE 9-1: WDT OPERATING MODES**

WDTE<1:0>	SWDTEN	Device Mode	WDT Mode
11	x	X	Active
10	x	Awake	Active
		Sleep	Disabled
01	1	X	Active
	0		Disabled
00	x	X	Disabled

**TABLE 9-2: WDT CLEARING CONDITIONS**

Conditions	WDT
WDTE<1:0> = 00	Cleared
WDTE<1:0> = 01 and SWDTEN = 0	
WDTE<1:0> = 10 and enters Sleep	
CLRWDT Command	
Oscillator Fail is Detected	
Exit Sleep + System Clock = T1OSC, EXTRC, INTOSC, EXTCLK	
Exit Sleep + System Clock = XT, HS, LP	Cleared until the end of OST
Changes INTOSC Divider (IRCFx bits)	Unaffected

## 9.3 Time-out Period

The WDTPS<4:0> bits of the WDTCON register set the time-out period from 1 ms to 256 seconds (nominal). After a Reset, the default time-out period is two seconds.

## 9.4 Clearing the WDT

The WDT is cleared when any of the following conditions occur:

- Any Reset
- CLRWDT instruction is executed
- Device enters Sleep
- Device wakes up from Sleep
- Oscillator fails
- WDT is disabled
- Oscillator Start-up Timer (OST) is running

See [Table 9-2](#) for more information.

## 9.5 Operation During Sleep

When the device enters Sleep, the WDT is cleared. If the WDT is enabled during Sleep, the WDT resumes counting.

When the device exits Sleep, the WDT is cleared again. The WDT remains clear until the OST, if enabled, completes. See [Section 5.0 “Oscillator Module \(with Fail-Safe Clock Monitor\)”](#) for more information on the OST.

When a WDT time-out occurs while the device is in Sleep, no Reset is generated. Instead, the device wakes up and resumes operation. The TO and PD bits in the STATUS register are changed to indicate the event. See the STATUS register ([Register 3-1](#)) for more information.

## 9.6 Register Definitions: Watchdog Control

### REGISTER 9-1: WDTCON: WATCHDOG TIMER CONTROL REGISTER

U-0	U-0	R/W-0/0	R/W-1/1	R/W-0/0	R/W-1/1	R/W-1/1	R/W-0/0
—	—	WDTPS<4:0> <sup>(1)</sup>					SWDTEN
bit 7							bit 0

#### Legend:

R = Readable bit	W = Writable bit	
u = Bit is unchanged	x = Bit is unknown	U = Unimplemented bit, read as '0'
'1' = Bit is set	'0' = Bit is cleared	-m/n = Value at POR and BOR/Value at all other Resets

bit 7-6 **Unimplemented:** Read as '0'

bit 5-1 **WDTPS<4:0>:** Watchdog Timer Period Select bits<sup>(1)</sup>

Bit Value = Prescale Rate

11111 = Reserved, results in minimum interval (1:32)

•  
•  
•

10011 = Reserved, results in minimum interval (1:32)

10010 = 1:8388608 (2<sup>23</sup>) (Interval 256s nominal)

10001 = 1:4194304 (2<sup>22</sup>) (Interval 128s nominal)

10000 = 1:2097152 (2<sup>21</sup>) (Interval 64s nominal)

01111 = 1:1048576 (2<sup>20</sup>) (Interval 32s nominal)

01110 = 1:524288 (2<sup>19</sup>) (Interval 16s nominal)

01101 = 1:262144 (2<sup>18</sup>) (Interval 8s nominal)

01100 = 1:131072 (2<sup>17</sup>) (Interval 4s nominal)

01011 = 1:65536 (Interval 2s nominal) (Reset value)

01010 = 1:32768 (Interval 1s nominal)

01001 = 1:16384 (Interval 512 ms nominal)

01000 = 1:8192 (Interval 256 ms nominal)

00111 = 1:4096 (Interval 128 ms nominal)

00110 = 1:2048 (Interval 64 ms nominal)

00101 = 1:1024 (Interval 32 ms nominal)

00100 = 1:512 (Interval 16 ms nominal)

00011 = 1:256 (Interval 8 ms nominal)

00010 = 1:128 (Interval 4 ms nominal)

00001 = 1:64 (Interval 2 ms nominal)

00000 = 1:32 (Interval 1 ms nominal)

bit 0 **SWDTEN:** Software Enable/Disable for Watchdog Timer bit

If WDTE<1:0> = 1x:

This bit is ignored.

If WDTE<1:0> = 01:

1 = WDT is turned on

0 = WDT is turned off

If WDTE<1:0> = 00:

This bit is ignored.

**Note 1:** Times are approximate. WDT time is based on 31 kHz LFINTOSC.

# PIC16(L)F1764/5/8/9

**TABLE 9-3: SUMMARY OF REGISTERS ASSOCIATED WITH WATCHDOG TIMER**

Name	Bit 7	Bit 6	Bit 5	Bit 4	Bit 3	Bit 2	Bit 1	Bit 0	Register on Page
OSCCON	SPLLEN	IRCF<3:0>				—	SCS<1:0>		84
STATUS	—	—	—	$\overline{TO}$	$\overline{PD}$	Z	DC	C	27
WDTCON	—	—	WDTPS<4:0>					SWDTEN	117

**Legend:** — = unimplemented location, read as '0'. Shaded cells are not used by the Watchdog Timer.

**TABLE 9-4: SUMMARY OF CONFIGURATION WORD WITH WATCHDOG TIMER**

Name	Bits	Bit -/7	Bit -/6	Bit 13/5	Bit 12/4	Bit 11/3	Bit 10/2	Bit 9/1	Bit 8/0	Register on Page
CONFIG1	13:8	—	—	FCMEN	IESO	$\overline{CLKOUTEN}$	BOREN<1:0>	—	63	
	7:0	$\overline{CP}$	MCLRE	$\overline{PWRTE}$	WDTE<1:0>	FOSC<2:0>				

**Legend:** — = unimplemented location, read as '0'. Shaded cells are not used by the Watchdog Timer.

## 10.0 FLASH PROGRAM MEMORY CONTROL

The Flash program memory is readable and writable during normal operation over the full VDD range. Program memory is indirectly addressed using Special Function Registers (SFRs). The SFRs used to access program memory are:

- PMCON1
- PMCON2
- PMDATL
- PMDATH
- PMADRL
- PMADRH

When accessing the program memory, the PMDATH:PMDATL register pair forms a 2-byte word that holds the 14-bit data for read/write, and the PMADRH:PMADRL register pair forms a 2-byte word that holds the 15-bit address of the program memory location being read.

The write time is controlled by an on-chip timer. The write/erase voltages are generated by an on-chip charge pump rated to operate over the operating voltage range of the device.

The Flash program memory can be protected in two ways: by code protection ( $\overline{CP}$  bit in the Configuration Words) and write protection (WRT<1:0> bits in the Configuration Words).

Code protection ( $\overline{CP} = 0$ ) disables access, reading and writing to the Flash program memory via external device programmers. Code protection does not affect the self-write and erase functionality. Code protection can only be reset by a device programmer performing a bulk erase to the device, clearing all Flash program memory, Configuration bits and User IDs.<sup>(1)</sup>

Write protection prohibits self-write and erase to a portion or all of the Flash program memory, as defined by the WRT<1:0> bits. Write protection does not affect a device programmer's ability to read, write or erase the device.

**Note 1:** Code protection of the entire Flash program memory array is enabled by clearing the  $\overline{CP}$  bit of the Configuration Words.

### 10.1 PMADRL and PMADRH Registers

The PMADRH:PMADRL register pair can address up to a maximum of 32K words of program memory. When selecting a program address value, the MSB of the address is written to the PMADRH register and the LSB is written to the PMADRL register.

### 10.1.1 PMCON1 AND PMCON2 REGISTERS

PMCON1 is the control register for Flash program memory accesses.

Control bits, RD and WR, initiate read and write, respectively. These bits cannot be cleared, only set, in software. They are cleared by hardware at completion of the read or write operation. The inability to clear the WR bit in software prevents the accidental, premature termination of a write operation.

The WREN bit, when set, will allow a write operation to occur. On power-up, the WREN bit is clear. The WRERR bit is set when a write operation is interrupted by a Reset during normal operation. In these situations, following Reset, the user can check the WRERR bit and execute the appropriate error handling routine.

The PMCON2 register is a write-only register. Attempting to read the PMCON2 register will return all '0's.

To enable writes to the program memory, a specific pattern (the unlock sequence), must be written to the PMCON2 register. The required unlock sequence prevents inadvertent writes to the program memory write latches and Flash program memory.

## 10.2 Flash Program Memory Overview

It is important to understand the Flash program memory structure for erase and programming operations. Flash program memory is arranged in rows. A row consists of a fixed number of 14-bit program memory words. A row is the minimum size that can be erased by user software.

After a row has been erased, the user can reprogram all or a portion of this row. Data to be written into the program memory row is written to 14-bit wide data write latches. These write latches are not directly accessible to the user, but may be loaded via sequential writes to the PMDATH:PMDATL register pair.

**Note:** If the user wants to modify only a portion of a previously programmed row, then the contents of the entire row must be read and saved in RAM prior to the erase. Then, new data and retained data can be written into the write latches to reprogram the row of Flash program memory. However, any unprogrammed locations can be written without first erasing the row. In this case, it is not necessary to save and rewrite the other previously programmed locations.

See [Table 10-1](#) for erase row size and the number of write latches for Flash program memory.

**TABLE 10-1: FLASH MEMORY ORGANIZATION BY DEVICE**

Device	Row Erase (words)	Write Latches (words)
PIC16(L)F1764	32	32
PIC16(L)F1765		
PIC16(L)F1768		
PIC16(L)F1769		

## 10.2.1 READING THE FLASH PROGRAM MEMORY

To read a program memory location, the user must:

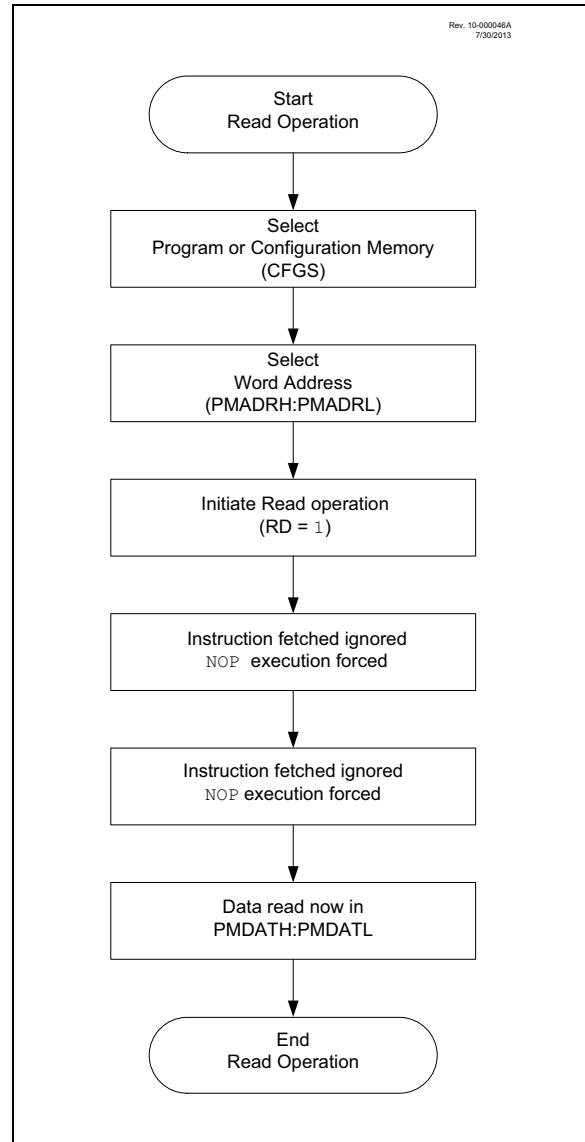
1. Write the desired address to the PMADRH:PMADRL register pair.
2. Clear the CFGS bit of the PMCON1 register.
3. Then, set control bit, RD, of the PMCON1 register.

Once the read control bit is set, the Program Flash Memory controller will use the second instruction cycle to read the data. This causes the second instruction, immediately following the "BSF PMCON1, RD" instruction, to be ignored. The data is available in the very next cycle, in the PMDATH:PMDATL register pair; therefore, it can be read as two bytes in the following instructions.

The PMDATH:PMDATL register pair will hold this value until another read or until it is written to by the user.

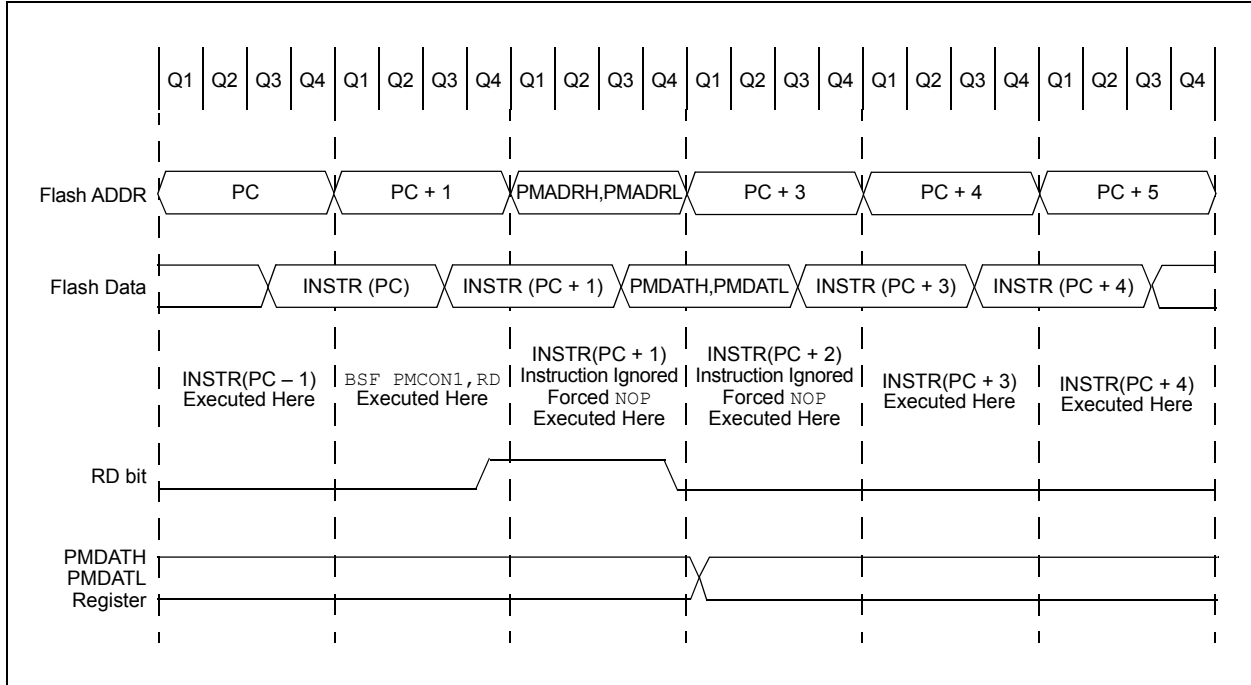
**Note:** The two instructions following a program memory read are required to be *NOPS*. This prevents the user from executing a 2-cycle instruction on the next instruction after the RD bit is set.

**FIGURE 10-1: FLASH PROGRAM MEMORY READ FLOWCHART**





**FIGURE 10-2: FLASH PROGRAM MEMORY READ CYCLE EXECUTION**



**EXAMPLE 10-1: FLASH PROGRAM MEMORY READ**

```

* This code block will read 1 word of program
* memory at the memory address:
  PROG_ADDR_HI : PROG_ADDR_LO
* data will be returned in the variables;
*  PROG_DATA_HI, PROG_DATA_LO

  BANKSEL  PMADRL          ; Select Bank for PMCON registers
  MOVLW    PROG_ADDR_LO    ;
  MOVWF    PMADRL          ; Store LSB of address
  MOVLW    PROG_ADDR_HI    ;
  MOVWF    PMADRH          ; Store MSB of address

  BCF      PMCON1,CFG5     ; Do not select Configuration Space
  BSF      PMCON1,RD       ; Initiate read
  NOP      ; Ignored (Figure 10-1)
  NOP      ; Ignored (Figure 10-1)

  MOVF     PMDATL,W        ; Get LSB of word
  MOVWF    PROG_DATA_LO    ; Store in user location
  MOVF     PMDATH,W        ; Get MSB of word
  MOVWF    PROG_DATA_HI    ; Store in user location
    
```

## 10.2.2 FLASH MEMORY UNLOCK SEQUENCE

The unlock sequence is a mechanism that protects the Flash program memory from unintended self-write programming or erasing. The sequence must be executed and completed without interruption to successfully complete any of the following operations:

- Row Erase
- Load program memory write latches
- Write of program memory write latches to program memory
- Write of program memory write latches to User IDs

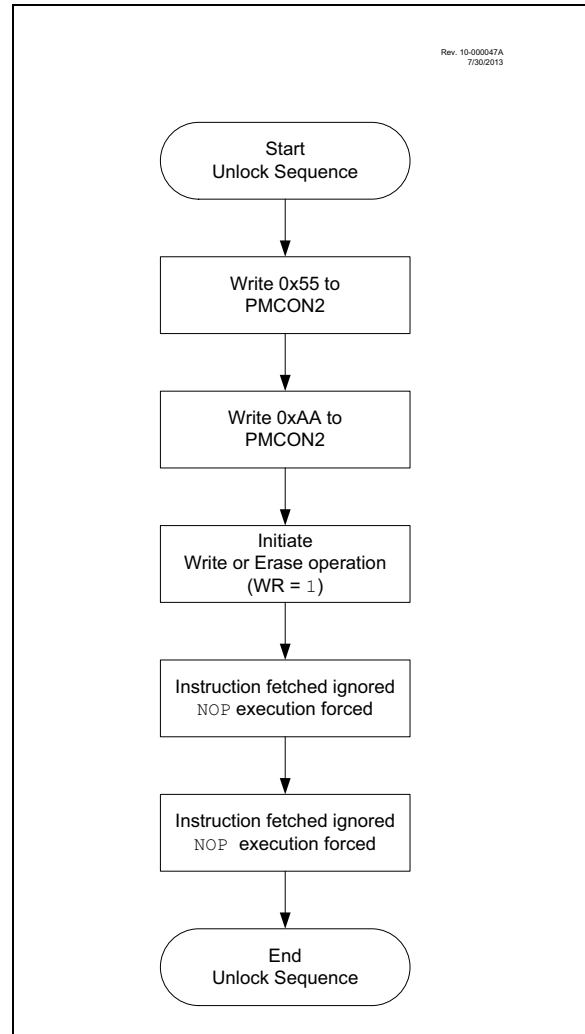
The unlock sequence consists of the following steps:

1. Write 55h to PMCON2.
2. Write AAh to PMCON2.
3. Set the WR bit in PMCON1.
4. NOP instruction.
5. NOP instruction.

Once the WR bit is set, the processor will always force two NOP instructions. When an erase row or program row operation is being performed, the processor will stall internal operations (typically 2 ms) until the operation is complete and then resume with the next instruction. When the operation is loading the program memory write latches, the processor will always force the two NOP instructions and continue uninterrupted with the next instruction.

Since the unlock sequence must not be interrupted, global interrupts should be disabled prior to the unlock sequence and re-enabled after the unlock sequence is completed.

**FIGURE 10-3: FLASH PROGRAM MEMORY UNLOCK SEQUENCE FLOWCHART**



## 10.2.3 ERASING FLASH PROGRAM MEMORY

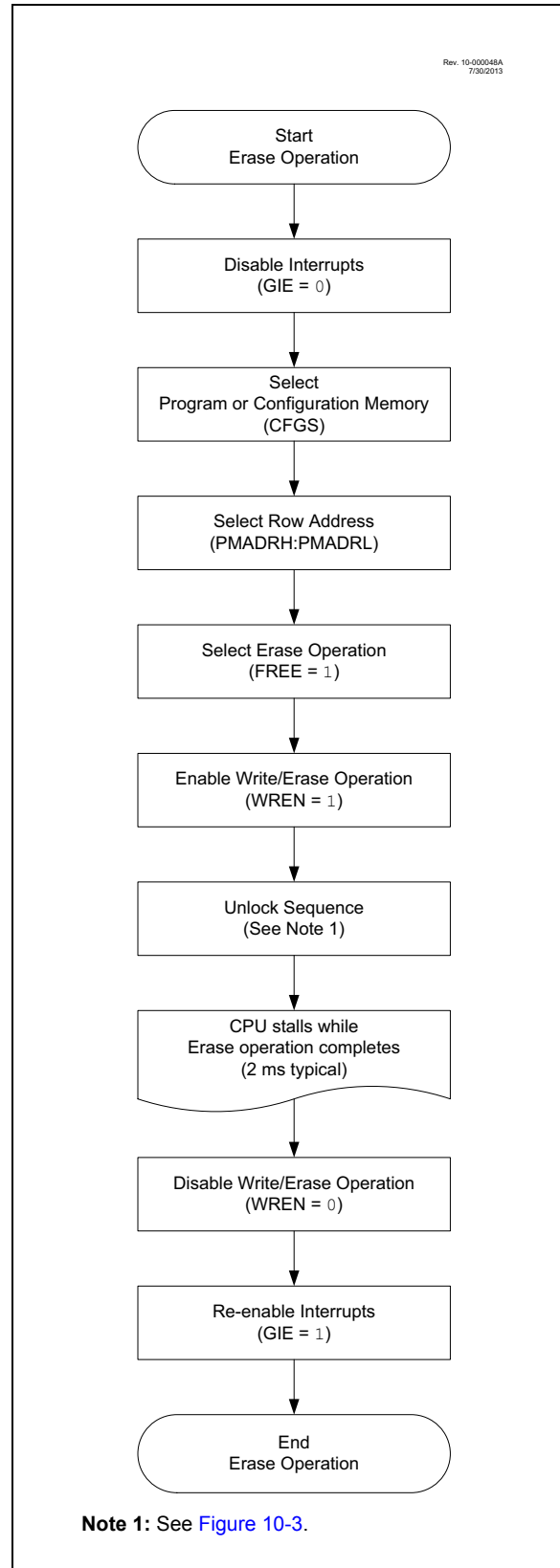
While executing code, program memory can only be erased by rows. To erase a row:

1. Load the PMADRH:PMADRL register pair with any address within the row to be erased.
2. Clear the CFGS bit of the PMCON1 register.
3. Set the FREE and WREN bits of the PMCON1 register.
4. Write 55h, then AAh, to PMCON2 (Flash programming unlock sequence).
5. Set control bit WR of the PMCON1 register to begin the erase operation.

See [Example 10-2](#).

After the “BSF PMCON1, WR” instruction, the processor requires two cycles to set up the erase operation. The user must place two NOP instructions immediately following the WR bit set instruction. The processor will halt internal operations for the typical 2 ms erase time. This is not Sleep mode as the clocks and peripherals will continue to run. After the erase cycle, the processor will resume operation with the third instruction after the PMCON1 write instruction.

**FIGURE 10-4: FLASH PROGRAM MEMORY ERASE FLOWCHART**



## EXAMPLE 10-2: ERASING ONE ROW OF PROGRAM MEMORY

```

; This row erase routine assumes the following:
; 1. A valid address within the erase row is loaded in ADDRH:ADDRL
; 2. ADDRH and ADDRL are located in shared data memory 0x70 - 0x7F (common RAM)

        BCF      INTCON,GIE      ; Disable ints so required sequences will execute properly
        BANKSEL PMADRL
        MOVF    ADDRL,W          ; Load lower 8 bits of erase address boundary
        MOVWF   PMADRL
        MOVF    ADDRH,W          ; Load upper 6 bits of erase address boundary
        MOVWF   PMADRH
        BCF     PMCON1,CFG5      ; Not configuration space
        BSF     PMCON1,FREE      ; Specify an erase operation
        BSF     PMCON1,WREN      ; Enable writes

        MOVLW   55h              ; Start of required sequence to initiate erase
        MOVWF   PMCON2           ; Write 55h
        MOVLW   0AAh             ;
        MOVWF   PMCON2           ; Write AAh
        BSF     PMCON1,WR        ; Set WR bit to begin erase
        NOP     ; NOP instructions are forced as processor starts
        NOP     ; row erase of program memory.
        ;
        ; The processor stalls until the erase process is complete
        ; after erase processor continues with 3rd instruction

        BCF     PMCON1,WREN      ; Disable writes
        BSF     INTCON,GIE       ; Enable interrupts
    
```

Required Sequence

## 10.2.4 WRITING TO FLASH PROGRAM MEMORY

Program memory is programmed using the following steps:

1. Load the address in PMADRH:PMADRL of the row to be programmed.
2. Load each write latch with data.
3. Initiate a programming operation.
4. Repeat Steps 1 through 3 until all data is written.

Before writing to program memory, the word(s) to be written must be erased or previously unwritten. Program memory can only be erased one row at a time. No automatic erase occurs upon the initiation of the write.

Program memory can be written one or more words at a time. The maximum number of words written at one time is equal to the number of write latches. See [Figure 10-5](#) (row writes to program memory with 32 write latches) for more details.

The write latches are aligned to the Flash row address boundary, defined by the upper ten bits of PMADRH:PMADRL (PMADRH<6:0>:PMADRL<7:5>), with the lower five bits of PMADRL (PMADRL<4:0>) determining the write latch being loaded. Write operations do not cross these boundaries. At the completion of a program memory write operation, the data in the write latches is reset to contain 0x3FFF.

The following steps should be completed to load the write latches and program a row of program memory. These steps are divided into two parts. First, each write latch is loaded with data from the PMDATH:PMDATL using the unlock sequence with LWLO = 1. When the last word to be loaded into the write latch is ready, the LWLO bit is cleared and the unlock sequence executed. This initiates the programming operation, writing all the latches into Flash program memory.

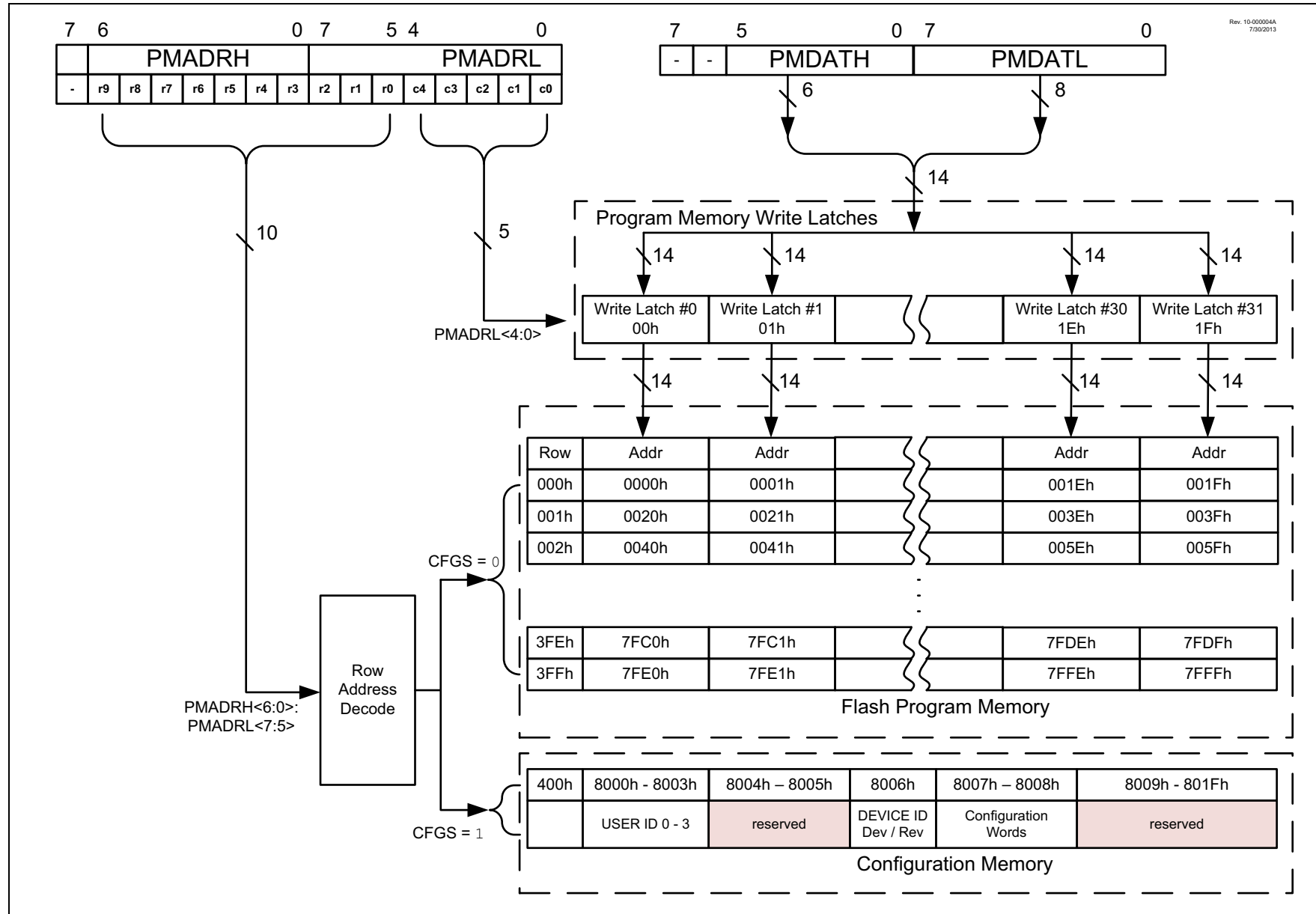
**Note:** The special unlock sequence is required to load a write latch with data or initiate a Flash programming operation. If the unlock sequence is interrupted, writing to the latches or program memory will not be initiated.

1. Set the WREN bit of the PMCON1 register.
2. Clear the CFGS bit of the PMCON1 register.
3. Set the LWLO bit of the PMCON1 register. When the LWLO bit of the PMCON1 register is '1', the write sequence will only load the write latches and will not initiate the write to Flash program memory.
4. Load the PMADRH:PMADRL register pair with the address of the location to be written.
5. Load the PMDATH:PMDATL register pair with the program memory data to be written.
6. Execute the unlock sequence ([Section 10.2.2 "Flash Memory Unlock Sequence"](#)). The write latch is now loaded.
7. Increment the PMADRH:PMADRL register pair to point to the next location.
8. Repeat Steps 5 through 7 until all but the last write latch has been loaded.
9. Clear the LWLO bit of the PMCON1 register. When the LWLO bit of the PMCON1 register is '0', the write sequence will initiate the write to Flash program memory.
10. Load the PMDATH:PMDATL register pair with the program memory data to be written.
11. Execute the unlock sequence ([Section 10.2.2 "Flash Memory Unlock Sequence"](#)). The entire program memory latch content is now written to Flash program memory.

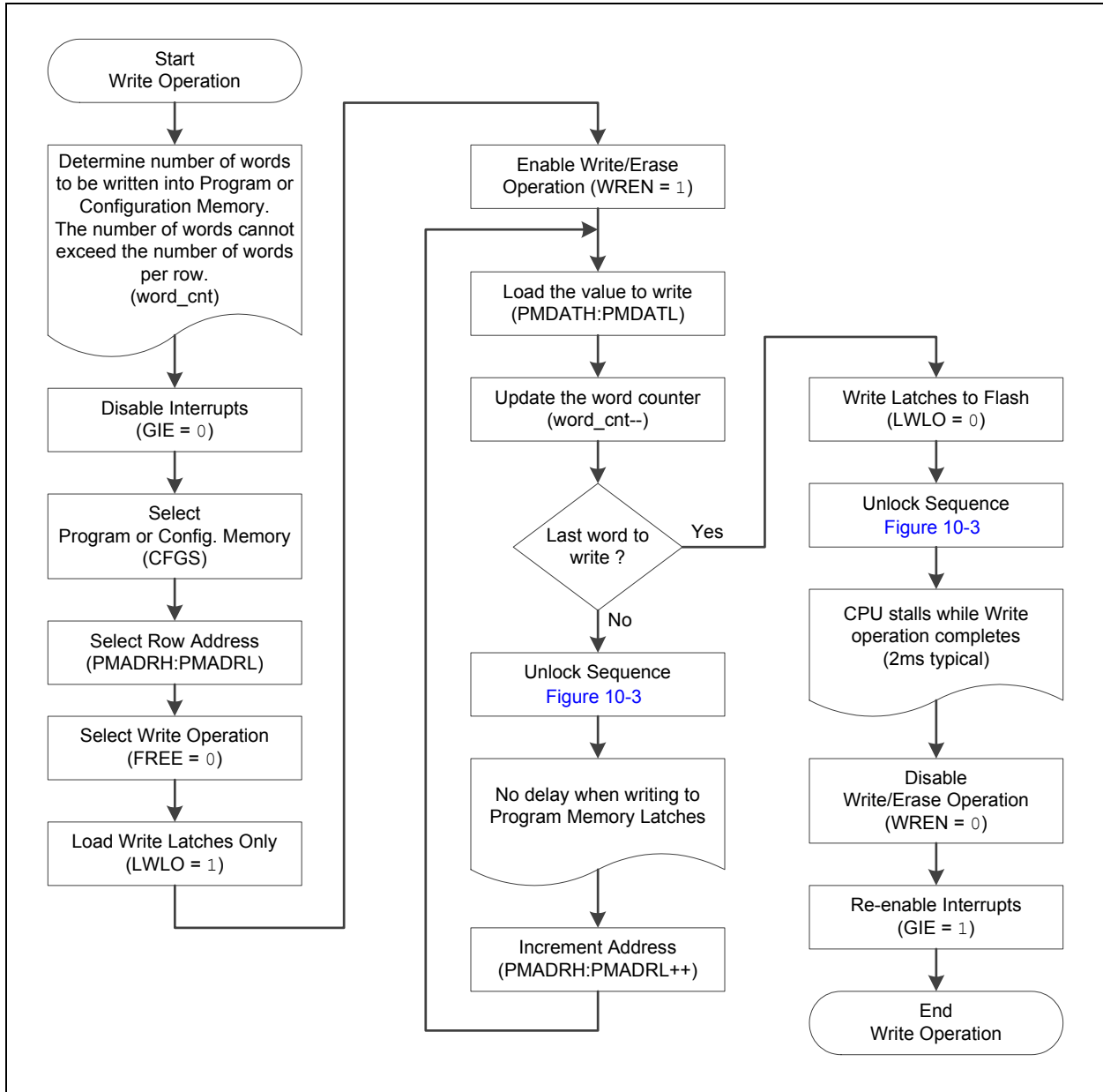
**Note:** The program memory write latches are reset to the blank state (0x3FFF) at the completion of every write or erase operation. As a result, it is not necessary to load all the program memory write latches. Unloaded latches will remain in the blank state.

An example of the complete write sequence is shown in [Example 10-3](#). The initial address is loaded into the PMADRH:PMADRL register pair; the data is loaded using Indirect Addressing.

**FIGURE 10-5: BLOCK WRITES TO FLASH PROGRAM MEMORY WITH 32 WRITE LATCHES**



**FIGURE 10-6: FLASH PROGRAM MEMORY WRITE FLOWCHART**



## EXAMPLE 10-3: WRITING TO FLASH PROGRAM MEMORY

```

; This write routine assumes the following:
; 1. 64 bytes of data are loaded, starting at the address in DATA_ADDR
; 2. Each word of data to be written is made up of two adjacent bytes in DATA_ADDR,
; stored in little endian format
; 3. A valid starting address (the least significant bits = 00000) is loaded in ADDRH:ADDRL
; 4. ADDRH and ADDRL are located in shared data memory 0x70 - 0x7F (common RAM)
;
      BCF      INTCON,GIE      ; Disable ints so required sequences will execute properly
      BANKSEL PMADRH          ; Bank 3
      MOVF    ADDRH,W         ; Load initial address
      MOVWF   PMADRH          ;
      MOVF    ADDRHL,W        ;
      MOVWF   PMADRL         ;
      MOVLW   LOW DATA_ADDR  ; Load initial data address
      MOVWF   FSR0L           ;
      MOVLW   HIGH DATA_ADDR ; Load initial data address
      MOVWF   FSR0H           ;
      BCF     PMCON1,CFGSS    ; Not configuration space
      BSF     PMCON1,WREN     ; Enable writes
      BSF     PMCON1,LWLO    ; Only Load Write Latches

LOOP
      MOVIW   FSR0++          ; Load first data byte into lower
      MOVWF   PMDATL         ;
      MOVIW   FSR0++          ; Load second data byte into upper
      MOVWF   PMDATH         ;

      MOVF    PMADRL,W        ; Check if lower bits of address are '00000'
      XORLW   0x1F           ; Check if we're on the last of 32 addresses
      ANDLW   0x1F           ;
      BTFSC   STATUS,Z        ; Exit if last of 32 words,
      GOTO    START_WRITE    ;

      MOVLW   55h             ; Start of required write sequence:
      MOVWF   PMCON2          ; Write 55h
      MOVLW   0AAh           ;
      MOVWF   PMCON2          ; Write AAh
      BSF     PMCON1,WR       ; Set WR bit to begin write
      NOP                    ; NOP instructions are forced as processor
                          ; loads program memory write latches
      NOP                    ;

      INCF    PMADRL,F        ; Still loading latches Increment address
      GOTO    LOOP           ; Write next latches

START_WRITE
      BCF     PMCON1,LWLO    ; No more loading latches - Actually start Flash program
                          ; memory write

      MOVLW   55h             ; Start of required write sequence:
      MOVWF   PMCON2          ; Write 55h
      MOVLW   0AAh           ;
      MOVWF   PMCON2          ; Write AAh
      BSF     PMCON1,WR       ; Set WR bit to begin write
      NOP                    ; NOP instructions are forced as processor writes
                          ; all the program memory write latches simultaneously
      NOP                    ; to program memory.
                          ; After NOPs, the processor
                          ; stalls until the self-write process is complete
                          ; after write processor continues with 3rd instruction

      BCF     PMCON1,WREN    ; Disable writes
      BSF     INTCON,GIE     ; Enable interrupts

```

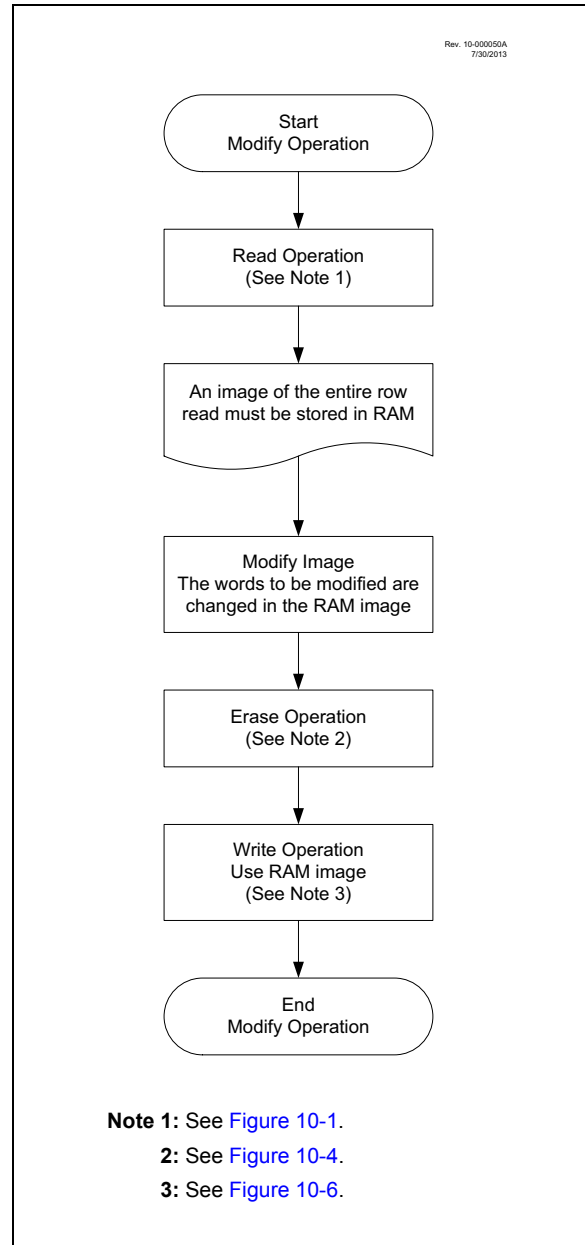


## 10.3 Modifying Flash Program Memory

When modifying existing data in a program memory row, and data within that row must be preserved, it must first be read and saved in a RAM image. Program memory is modified using the following steps:

1. Load the starting address of the row to be modified.
2. Read the existing data from the row into a RAM image.
3. Modify the RAM image to contain the new data to be written into program memory.
4. Load the starting address of the row to be rewritten.
5. Erase the program memory row.
6. Load the write latches with data from the RAM image.
7. Initiate a programming operation.

**FIGURE 10-7: FLASH PROGRAM MEMORY MODIFY FLOWCHART**



## 10.4 User ID, Device ID and Configuration Word Access

Instead of accessing program memory, the User IDs, Device ID/Revision ID and Configuration Words can be accessed when  $CFG5 = 1$  in the PMCON1 register. This is the region that would be pointed to by  $PC<15> = 1$ , but not all addresses are accessible. Different access may exist for reads and writes. Refer to [Table 10-2](#).

When read access is initiated on an address outside the parameters listed in [Table 10-2](#), the PMDATH:PMDATL register pair is cleared, reading back '0's.

**TABLE 10-2: USER ID, DEVICE ID AND CONFIGURATION WORD ACCESS (CFG5 = 1)**

Address	Function	Read Access	Write Access
8000h-8003h	User IDs	Yes	Yes
8005h-8006h	Device ID/Revision ID	Yes	No
8007h-8008h	Configuration Words 1 and 2	Yes	No

### EXAMPLE 10-4: CONFIGURATION WORD AND DEVICE ID ACCESS

```

* This code block will read 1 word of program memory at the memory address:
*   PROG_ADDR_LO (must be 00h-08h) data will be returned in the variables;
*   PROG_DATA_HI, PROG_DATA_LO

    BANKSEL    PMADRL           ; Select correct Bank
    MOVLW     PROG_ADDR_LO     ;
    MOVWF     PMADRL           ; Store LSB of address
    CLRF      PMADRH           ; Clear MSB of address

    BSF       PMCON1,CFG5      ; Select Configuration Space
    BCF       INTCON,GIE       ; Disable interrupts
    BSF       PMCON1,RD        ; Initiate read
    NOP                          ; Executed (See Figure 10-2)
    NOP                          ; Ignored (See Figure 10-2)
    BSF       INTCON,GIE       ; Restore interrupts

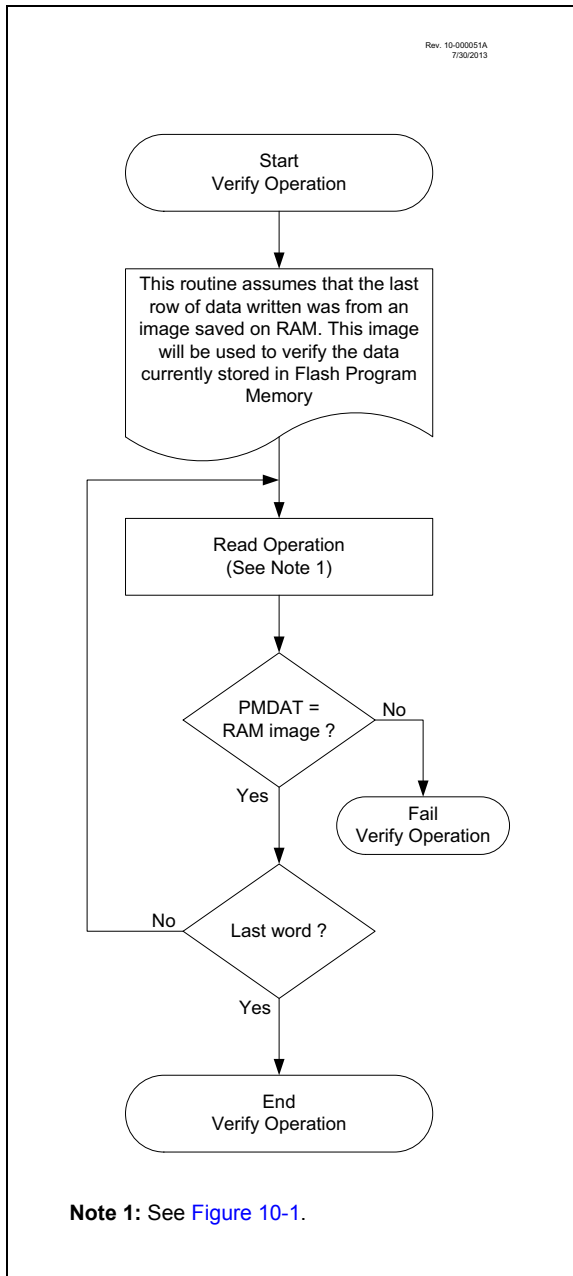
    MOVF      PMDATL,W         ; Get LSB of word
    MOVWF     PROG_DATA_LO     ; Store in user location
    MOVF      PMDATH,W         ; Get MSB of word
    MOVWF     PROG_DATA_HI     ; Store in user location

```

## 10.5 Write/Verify

It is considered good programming practice to verify that program memory writes agree with the intended value. Since program memory is stored as a full page then the stored program memory contents are compared with the intended data stored in RAM after the last write is complete.

**FIGURE 10-8: FLASH PROGRAM MEMORY VERIFY FLOWCHART**



## 10.6 Register Definitions: Flash Program Memory Control

### REGISTER 10-1: PMDATL: PROGRAM MEMORY DATA LOW BYTE REGISTER

R/W-x/u	R/W-x/u	R/W-x/u	R/W-x/u	R/W-x/u	R/W-x/u	R/W-x/u	R/W-x/u
PMDAT<7:0>							
bit 7							bit 0

**Legend:**

R = Readable bit	W = Writable bit	
u = Bit is unchanged	x = Bit is unknown	U = Unimplemented bit, read as '0'
'1' = Bit is set	'0' = Bit is cleared	-n/n = Value at POR and BOR/Value at all other Resets

bit 7-0      **PMDAT<7:0>**: Read/Write Value for Least Significant bits of Program Memory bits

### REGISTER 10-2: PMDATH: PROGRAM MEMORY DATA HIGH BYTE REGISTER

U-0	U-0	R/W-x/u	R/W-x/u	R/W-x/u	R/W-x/u	R/W-x/u	R/W-x/u
—	—	PMDAT<13:8>					
bit 7							bit 0

**Legend:**

R = Readable bit	W = Writable bit	
u = Bit is unchanged	x = Bit is unknown	U = Unimplemented bit, read as '0'
'1' = Bit is set	'0' = Bit is cleared	-n/n = Value at POR and BOR/Value at all other Resets

bit 7-6      **Unimplemented**: Read as '0'

bit 5-0      **PMDAT<13:8>**: Read/Write Value for Most Significant bits of Program Memory bits

# PIC16(L)F1764/5/8/9

## REGISTER 10-3: PMADRL: PROGRAM MEMORY ADDRESS LOW BYTE REGISTER

R/W-0/0	R/W-0/0	R/W-0/0	R/W-0/0	R/W-0/0	R/W-0/0	R/W-0/0	R/W-0/0
PMADR<7:0>							
bit 7							bit 0

### Legend:

R = Readable bit

W = Writable bit

u = Bit is unchanged

x = Bit is unknown

U = Unimplemented bit, read as '0'

'1' = Bit is set

'0' = Bit is cleared

-n/n = Value at POR and BOR/Value at all other Resets

bit 7-0      **PMADR<7:0>**: Specifies the Least Significant bits for Program Memory Address bits

## REGISTER 10-4: PMADRH: PROGRAM MEMORY ADDRESS HIGH BYTE REGISTER

U-1	R/W-0/0	R/W-0/0	R/W-0/0	R/W-0/0	R/W-0/0	R/W-0/0	R/W-0/0
—(1)	PMADR<14:8>						
bit 7							bit 0

### Legend:

R = Readable bit

W = Writable bit

u = Bit is unchanged

x = Bit is unknown

U = Unimplemented bit, read as '0'

'1' = Bit is set

'0' = Bit is cleared

-n/n = Value at POR and BOR/Value at all other Resets

bit 7      **Unimplemented:** Read as '1'

bit 6-0      **PMADR<14:8>**: Specifies the Most Significant bits for Program Memory Address bits

**Note 1:** Unimplemented, read as '1'.

# PIC16(L)F1764/5/8/9

## REGISTER 10-5: PMCON1: PROGRAM MEMORY CONTROL 1 REGISTER

U-1	R/W-0/0	R/W-0/0	R/W/HC-0/0	R/W/HC-x/q <sup>(2)</sup>	R/W-0/0	R/S/HC-0/0	R/S/HC-0/0
— <sup>(1)</sup>	CFGFS	LWLO <sup>(3)</sup>	FREE	WRERR	WREN	WR	RD
bit 7							bit 0

### Legend:

R = Readable bit	W = Writable bit	U = Unimplemented bit, read as '0'
S = Settable Only bit	x = Bit is unknown	-n/n = Value at POR and BOR/Value at all other Resets
'1' = Bit is set	'0' = Bit is cleared	HC = Hardware Clearable bit

- bit 7      **Unimplemented:** Read as '1'
- bit 6      **CFGFS:** Configuration Select bit  
           1 = Accesses Configuration, User ID and Device ID registers  
           0 = Accesses Flash program memory
- bit 5      **LWLO:** Load Write Latches Only bit<sup>(3)</sup>  
           1 = Only the addressed program memory write latch is loaded/updated on the next WR command  
           0 = The addressed program memory write latch is loaded/updated and a write of all program memory write latches will be initiated on the next WR command
- bit 4      **FREE:** Program Flash Erase Enable bit  
           1 = Performs an erase operation on the next WR command (hardware cleared upon completion)  
           0 = Performs a write operation on the next WR command
- bit 3      **WRERR:** Program/Erase Error Flag bit<sup>(2)</sup>  
           1 = Condition indicates an improper program or erase sequence attempt, or termination (bit is set automatically on any set attempt (writes '1') of the WR bit)  
           0 = The program or erase operation completed normally
- bit 2      **WREN:** Program/Erase Enable bit  
           1 = Allows program/erase cycles  
           0 = Inhibits programming/erasing of program Flash
- bit 1      **WR:** Write Control bit  
           1 = Initiates a Flash program/erase operation  
               The operation is self-timed and the bit is cleared by hardware once operation is complete.  
               The WR bit can only be set (not cleared) in software.  
           0 = Program/erase operation to the Flash is complete and inactive
- bit 0      **RD:** Read Control bit  
           1 = Initiates a program Flash read  
               Read takes one cycle. RD is cleared in hardware. The RD bit can only be set (not cleared) in software.  
           0 = Does not initiate a program Flash read

- Note 1:** Unimplemented bit, read as '1'.
- 2:** The WRERR bit is automatically set by hardware when a program memory write or erase operation is started (WR = 1).
- 3:** The LWLO bit is ignored during a program memory erase operation (FREE = 1).

# PIC16(L)F1764/5/8/9

**REGISTER 10-6: PMCON2: PROGRAM MEMORY CONTROL 2 REGISTER**

W-0/0	W-0/0	W-0/0	W-0/0	W-0/0	W-0/0	W-0/0	W-0/0
Program Memory Control Register 2							
bit 7							bit 0

**Legend:**

R = Readable bit	W = Writable bit	
S = Bit can only be set	x = Bit is unknown	U = Unimplemented bit, read as '0'
'1' = Bit is set	'0' = Bit is cleared	-n/n = Value at POR and BOR/Value at all other Resets

bit 7-0      **Program Memory Control 2:** Flash Memory Unlock Pattern bits  
 To unlock writes, 55h must be written first, followed by AAh, before setting the WR bit of the PMCON1 register. The value written to this register is used to unlock the writes. There are specific timing requirements on these writes.

**TABLE 10-3: SUMMARY OF REGISTERS ASSOCIATED WITH FLASH PROGRAM MEMORY**

Name	Bit 7	Bit 6	Bit 5	Bit 4	Bit 3	Bit 2	Bit 1	Bit 0	Register on Page
INTCON	GIE	PEIE	TMR0IE	INTE	IOCIE	TMR0IF	INTF	IOCIF	101
PMCON1	— <sup>(1)</sup>	CFGS	LWLO	FREE	WRERR	WREN	WR	RD	134
PMCON2	Program Memory Control Register 2								135
PMADRL	PMADRL<7:0>								133
PMADRH	— <sup>(1)</sup>	PMADRH<6:0>							133
PMDATL	PMDATL<7:0>								132
PMDATH	—	—	PMDATH<5:0>						132

**Legend:** — = unimplemented location, read as '0'. Shaded cells are not used by Flash program memory.

**Note 1:** Unimplemented, read as '1'.

**TABLE 10-4: SUMMARY OF CONFIGURATION WORD WITH FLASH PROGRAM MEMORY**

Name	Bits	Bit -/7	Bit -/6	Bit 13/5	Bit 12/4	Bit 11/3	Bit 10/2	Bit 9/1	Bit 8/0	Register on Page
CONFIG1	13:8	—	—	FCMEN	IESO	CLKOUTEN	BOREN<1:0>		—	63
	7:0	$\overline{CP}$	MCLRE	$\overline{PWRT\overline{E}}$	WDTE<1:0>		FOSC<2:0>			
CONFIG2	13:8	—	—	LVP	$\overline{DEBUG}$	$\overline{LPBOR}$	BORV	STVREN	PLLEN	65
	7:0	$\overline{ZCD}$	—	—	—	—	PPS1WAY	WRT<1:0>		

**Legend:** — = unimplemented location, read as '0'. Shaded cells are not used by Flash program memory.

## 11.0 I/O PORTS

Each port has six standard registers for its operation. These registers are:

- TRISx registers (Data Direction)
- PORTx registers (reads the levels on the pins of the device)
- LATx registers (Output Latch)
- INLVLx (Input Level Control)
- ODCONx registers (Open-Drain)
- SLRCONx registers (Slew Rate)

Some ports may have one or more of the following additional registers. These registers are:

- ANSELx (Analog Select)
- WPUx (Weak Pull-up)

In general, when a peripheral is enabled on a port pin, that pin cannot be used as a general purpose output. However, the pin can still be read.

**TABLE 11-1: PORT AVAILABILITY PER DEVICE**

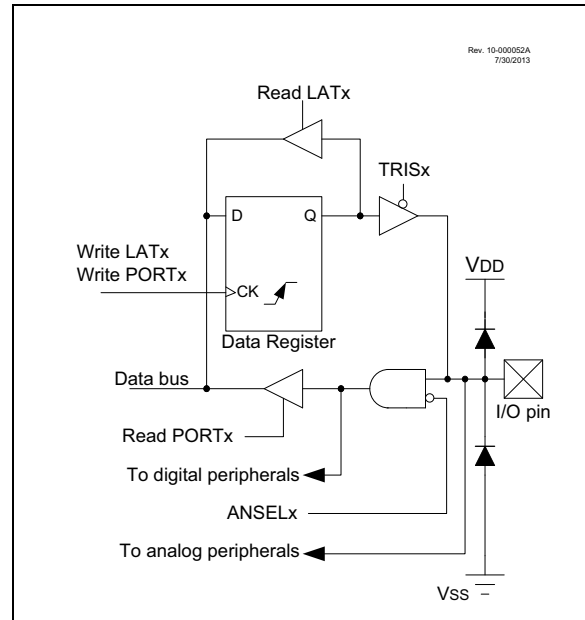
Device	PORTA	PORTB	PORTC
PIC16(L)F1764	•		•
PIC16(L)F1765	•		•
PIC16(L)F1768	•	•	•
PIC16(L)F1769	•	•	•

The Data Latch (LATx registers) is useful for Read-Modify-Write operations on the value that the I/O pins are driving.

A write operation to the LATx register has the same effect as a write to the corresponding PORTx register. A read of the LATx register reads the values held in the I/O PORT latches, while a read of the PORTx register reads the actual I/O pin value.

Ports that support analog inputs have an associated ANSELx register. When an ANSEL bit is set, the digital input buffer associated with that bit is disabled. Disabling the input buffer prevents analog signal levels on the pin between a logic high and low from causing excessive current in the logic input circuitry. A simplified model of a generic I/O port, without the interfaces to other peripherals, is shown in [Figure 11-1](#).

**FIGURE 11-1: GENERIC I/O PORT OPERATION**



## 11.1 PORTA Registers

### 11.1.1 DATA REGISTER

PORTA is a 6-bit wide, bidirectional port. The corresponding Data Direction register is TRISA ([Register 11-2](#)). Setting a TRISA bit (= 1) will make the corresponding PORTA pin an input (i.e., disables the output driver). Clearing a TRISA bit (= 0) will make the corresponding PORTA pin an output (i.e., enables the output driver and puts the contents of the output latch on the selected pin). The exception is RA3, which is input-only and its TRISA bit will always read as '1'. [Example 11-1](#) shows how to initialize PORTA.

Reading the PORTA register ([Register 11-1](#)) reads the status of the pins, whereas writing to it, will write to the PORT latch. All write operations are Read-Modify-Write operations. Therefore, a write to a port implies that the port pins are read, this value is modified and then written to the PORTA Data Latch (LATA).

### 11.1.2 DIRECTION CONTROL

The TRISA register ([Register 11-2](#)) controls the PORTA pin output drivers, even when they are being used as analog inputs. The user should ensure the bits in the TRISA register are maintained set when using them as analog inputs. I/O pins configured as analog inputs always read '0'.



## 11.1.3 OPEN-DRAIN CONTROL

The ODCONA register ([Register 11-6](#)) controls the open-drain feature of the port. Open-drain operation is independently selected for each pin. When an ODCONA bit is set, the corresponding port output becomes an open-drain driver, capable of sinking current only. When an ODCONA bit is cleared, the corresponding port output pin is the standard push-pull drive capable of sourcing and sinking current.

## 11.1.4 SLEW RATE CONTROL

The SLRCONA register ([Register 11-7](#)) controls the slew rate option for each port pin. Slew rate control is independently selectable for each port pin. When an SLRCONA bit is set, the corresponding port pin drive is slew rate limited. When an SLRCONA bit is cleared, the corresponding port pin drive slews at the maximum rate possible.

## 11.1.5 INPUT THRESHOLD CONTROL

The INLVLA register ([Register 11-8](#)) controls the input voltage threshold for each of the available PORTA input pins. A selection between the Schmitt Trigger CMOS or the TTL compatible thresholds is available. The input threshold is important in determining the value of a read of the PORTA register and also the level at which an Interrupt-On-Change occurs, if that feature is enabled. See [Table 36-4](#) for more information on threshold levels.

**Note:** Changing the input threshold selection should be performed while all peripheral modules are disabled. Changing the threshold level during the time a module is active may inadvertently generate a transition associated with an input pin, regardless of the actual voltage level on that pin.

## 11.1.6 ANALOG CONTROL

The ANSELA register ([Register 11-4](#)) is used to configure the Input mode of an I/O pin to analog. Setting the appropriate ANSELA bit high will cause all digital reads on the pin to be read as '0' and allow analog functions on the pin to operate correctly.

The state of the ANSELA bits has no effect on digital output functions. A pin with TRISx clear and ANSELx set will still operate as a digital output, but the Input mode will be analog. This can cause unexpected behavior when executing Read-Modify-Write instructions on the affected port.

**Note:** The ANSELA bits default to the Analog mode after Reset. To use any pins as digital general purpose or peripheral inputs, the corresponding ANSELA bits must be initialized to '0' by user software.

## EXAMPLE 11-1: INITIALIZING PORTA

```
; This code example illustrates
; initializing the PORTA register. The
; other ports are initialized in the same
; manner.

BANKSEL PORTA      ;
CLRF   PORTA       ;Init PORTA
BANKSEL LATA       ;Data Latch
CLRF   LATA        ;
BANKSEL ANSELA     ;
CLRF   ANSELA      ;digital I/O
BANKSEL TRISA      ;
MOVLW  B'00111000' ;Set RA<5:3> as inputs
MOVWF  TRISA       ;and set RA<2:0> as
                    ;outputs
```

## 11.1.7 PORTA FUNCTIONS AND OUTPUT PRIORITIES

Each PORTA pin is multiplexed with other functions.

Each pin defaults to the PORT latch data after Reset. Other functions are selected with the Peripheral Pin Select (PPS) logic. See [Section 12.0 "Peripheral Pin Select \(PPS\) Module"](#) for more information.

Analog input functions, such as the ADC and comparator inputs, are not shown in the Peripheral Pin Select lists. These inputs are active when the I/O pin is set for Analog mode using the ANSELA register. Digital output functions may continue to control the pin when it is in Analog mode.

## 11.2 Register Definitions: PORTA

### REGISTER 11-1: PORTA: PORTA REGISTER

U-0	U-0	R/W-x/x	R/W-x/x	R-x/x	R/W-x/x	R/W-x/x	R/W-x/x
—	—	RA<5:0> <sup>(1)</sup>					
bit 7							bit 0

#### Legend:

R = Readable bit	W = Writable bit	
u = Bit is unchanged	x = Bit is unknown	U = Unimplemented bit, read as '0'
'1' = Bit is set	'0' = Bit is cleared	-n/n = Value at POR and BOR/Value at all other Resets

bit 7-6      **Unimplemented:** Read as '0'  
bit 5-0      **RA<5:0>:** PORTA I/O Value bits<sup>(1)</sup>  
                1 = Port pin is ≥ VIH  
                0 = Port pin is ≤ VIL

**Note 1:** Writes to PORTA are actually written to the corresponding LATA register. Reads from PORTA are the return of actual I/O pin values.

### REGISTER 11-2: TRISA: PORTA TRI-STATE REGISTER

U-0	U-0	R/W-1/1	R/W-1/1	U-1	R/W-1/1	R/W-1/1	R/W-1/1
—	—	TRISA<5:4>		— <sup>(1)</sup>	TRISA<2:0>		
bit 7							bit 0

#### Legend:

R = Readable bit	W = Writable bit	
u = Bit is unchanged	x = Bit is unknown	U = Unimplemented bit, read as '0'
'1' = Bit is set	'0' = Bit is cleared	-n/n = Value at POR and BOR/Value at all other Resets

bit 7-6      **Unimplemented:** Read as '0'  
bit 5-4      **TRISA<5:4>:** PORTA Tri-State Control bit  
                1 = PORTA pin is configured as an input (tri-stated)  
                0 = PORTA pin is configured as an output  
bit 3         **Unimplemented:** Read as '1'<sup>(1)</sup>  
bit 2-0      **TRISA<2:0>:** PORTA Tri-State Control bit  
                1 = PORTA pin is configured as an input (tri-stated)  
                0 = PORTA pin is configured as an output

**Note 1:** Unimplemented, read as '1'.

## REGISTER 11-3: LATA: PORTA DATA LATCH REGISTER

U-0	U-0	R/W-x/u	R/W-x/u	U-0	R/W-x/u	R/W-x/u	R/W-x/u
—	—	LATA<5:4> <sup>(1)</sup>		—	LATA<2:0> <sup>(1)</sup>		
bit 7				bit 0			

### Legend:

R = Readable bit	W = Writable bit	
u = Bit is unchanged	x = Bit is unknown	U = Unimplemented bit, read as '0'
'1' = Bit is set	'0' = Bit is cleared	-n/n = Value at POR and BOR/Value at all other Resets

- bit 7-6      **Unimplemented:** Read as '0'
- bit 5-4      **LATA<5:4>:** RA<5:4> Output Latch Value bits<sup>(1)</sup>
- bit 3        **Unimplemented:** Read as '0'
- bit 2-0      **LATA<2:0>:** RA<2:0> Output Latch Value bits<sup>(1)</sup>

**Note 1:** Writes to PORTA are actually written to the corresponding LATA register. Reads from PORTA are the return of actual I/O pin values.

## REGISTER 11-4: ANSELA: PORTA ANALOG SELECT REGISTER

U-0	U-0	U-0	R/W-1/1	U-0	R/W-1/1	R/W-1/1	R/W-1/1
—	—	—	ANSA4	—	ANSA<2:0>		
bit 7				bit 0			

### Legend:

R = Readable bit	W = Writable bit	
u = Bit is unchanged	x = Bit is unknown	U = Unimplemented bit, read as '0'
'1' = Bit is set	'0' = Bit is cleared	-n/n = Value at POR and BOR/Value at all other Resets

- bit 7-5      **Unimplemented:** Read as '0'
- bit 4        **ANSA4:** Analog Select Between Analog or Digital Function on RA4 Pin bit
  - 1 = Analog input; pin is assigned as an analog input, digital input buffer is disabled<sup>(1)</sup>
  - 0 = Digital I/O; pin is assigned to port or digital special function
- bit 3        **Unimplemented:** Read as '0'
- bit 2-0      **ANSA<2:0>:** Analog Select Between Analog or Digital Function on RA<2:0> Pins bits
  - 1 = Analog input; pin is assigned as an analog input, digital input buffer is disabled<sup>(1)</sup>
  - 0 = Digital I/O; pin is assigned to port or digital special function

**Note 1:** When setting a pin to an analog input, the corresponding TRISx bit must be set to Input mode in order to allow external control of the voltage on the pin.

## REGISTER 11-5: WPUA: WEAK PULL-UP PORTA REGISTER

U-0	U-0	R/W-1/1	R/W-1/1	R/W-1/1	R/W-1/1	R/W-1/1	R/W-1/1
—	—	WPUA<5:0> <sup>(1,2)</sup>					
bit 7							bit 0

### Legend:

R = Readable bit                      W = Writable bit  
u = Bit is unchanged                  x = Bit is unknown                  U = Unimplemented bit, read as '0'  
'1' = Bit is set                          '0' = Bit is cleared                  -n/n = Value at POR and BOR/Value at all other Resets

bit 7-6            **Unimplemented:** Read as '0'  
bit 5-0            **WPUA<5:0>**: Weak Pull-up PORTA Register bits<sup>(1,2)</sup>  
                    1 = Pull-up is enabled  
                    0 = Pull-up is disabled

**Note 1:** The global WPUEN bit of the OPTION\_REG register must be cleared for individual pull-ups to be enabled.  
**2:** The weak pull-up device is automatically disabled if the pin is configured as an output.

## REGISTER 11-6: ODCONA: PORTA OPEN-DRAIN CONTROL REGISTER

U-0	U-0	R/W-0/0	R/W-0/0	U-0	R/W-0/0	R/W-0/0	R/W-0/0
—	—	ODA<5:4>		—	ODA<2:0>		
bit 7							bit 0

### Legend:

R = Readable bit                      W = Writable bit  
u = Bit is unchanged                  x = Bit is unknown                  U = Unimplemented bit, read as '0'  
'1' = Bit is set                          '0' = Bit is cleared                  -n/n = Value at POR and BOR/Value at all other Resets

bit 7-6            **Unimplemented:** Read as '0'  
bit 5-4            **ODA<5:4>**: PORTA Open-Drain Enable bits  
                    For RA<5:4> Pins:  
                    1 = Port pins operate as open-drain drive (sink current only)  
                    0 = Port pins operate as standard push-pull drive (source and sink current)  
bit 3              **Unimplemented:** Read as '0'  
bit 2-0            **ODA<2:0>**: PORTA Open-Drain Enable bits  
                    For RA<2:0> Pins:  
                    1 = Port pins operate as open-drain drive (sink current only)  
                    0 = Port pins operate as standard push-pull drive (source and sink current)

# PIC16(L)F1764/5/8/9

## REGISTER 11-7: SLRCONA: PORTA SLEW RATE CONTROL REGISTER

U-0	U-0	R/W-1/1	R/W-1/1	U-0	R/W-1/1	R/W-1/1	R/W-1/1
—	—	SLRA<5:4>		—	SLRA<2:0>		
bit 7				bit 0			

### Legend:

R = Readable bit                      W = Writable bit  
u = Bit is unchanged                  x = Bit is unknown                  U = Unimplemented bit, read as '0'  
'1' = Bit is set                          '0' = Bit is cleared                  -n/n = Value at POR and BOR/Value at all other Resets

bit 7-6            **Unimplemented:** Read as '0'  
bit 5-4            **SLRA<5:4>:** PORTA Slew Rate Enable bits  
                    For RA<5:4> Pins:  
                    1 = Port pin slew rate is limited  
                    0 = Port pin slews at maximum rate  
bit 3              **Unimplemented:** Read as '0'  
bit 2-0            **SLRA<2:0>:** PORTA Slew Rate Enable bits  
                    For RA<2:0> Pins:  
                    1 = Port pin slew rate is limited  
                    0 = Port pin slews at maximum rate

## REGISTER 11-8: INLVLA: PORTA INPUT LEVEL CONTROL REGISTER

U-0	U-0	R/W-0/0	R/W-0/0	R/W-0/0	R/W-0/0	R/W-0/0	R/W-0/0
—	—	INLVLA<5:0>					
bit 7				bit 0			

### Legend:

R = Readable bit                      W = Writable bit  
u = Bit is unchanged                  x = Bit is unknown                  U = Unimplemented bit, read as '0'  
'1' = Bit is set                          '0' = Bit is cleared                  -n/n = Value at POR and BOR/Value at all other Resets

bit 7-6            **Unimplemented:** Read as '0'  
bit 5-0            **INLVLA<5:0>:** PORTA Input Level Select bits  
                    For RA<5:0> Pins:  
                    1 = Port pin digital input operates with ST thresholds  
                    0 = Port pin digital input operates with TTL thresholds

# PIC16(L)F1764/5/8/9

**TABLE 11-2: SUMMARY OF REGISTERS ASSOCIATED WITH PORTA**

Name	Bit 7	Bit 6	Bit 5	Bit 4	Bit 3	Bit 2	Bit 1	Bit 0	Register on Page
ANSELA	—	—	—	ANSA4	—	ANSA<2:0>			139
INLVLA	—	—	INLVLA<5:0>						141
LATA	—	—	LATA<5:4>		—	LATA<2:0>			139
ODCONA	—	—	ODA<5:4>		—	ODA<2:0>			140
OPTION_REG	$\overline{\text{WPUEN}}$	INTEDG	TMR0CS	TMR0SE	PSA	PS<2:0>			216
PORTA	—	—	RA<5:0>						138
SLRCONA	—	—	SLRA<5:4>		—	SLRA<2:0>			141
TRISA	—	—	TRISA<5:4>		— <sup>(1)</sup>	TRISA<2:0>			138
WPUA	—	—	WPUA<5:0>						140

**Legend:** — = unimplemented location, read as '0'. Shaded cells are not used by PORTA.

**Note 1:** Unimplemented, read as '1'.

**TABLE 11-3: SUMMARY OF CONFIGURATION WORD WITH PORTA**

Name	Bits	Bit -/7	Bit -/6	Bit 13/5	Bit 12/4	Bit 11/3	Bit 10/2	Bit 9/1	Bit 8/0	Register on Page
CONFIG1	13:8	—	—	FCMEN	IESO	$\overline{\text{CLKOUTEN}}$	BOREN<1:0>		—	63
	7:0	$\overline{\text{CP}}$	MCLRE	$\overline{\text{PWRTE}}$	WDTE<1:0>		FOSC<2:0>			

**Legend:** — = unimplemented location, read as '0'. Shaded cells are not used by PORTA.

## 11.3 PORTB Registers (PIC16(L)F1768/9 only)

### 11.3.1 DATA REGISTER

PORTB is a 4-bit wide, bidirectional port. The corresponding Data Direction register is TRISB (Register 11-10). Setting a TRISB bit (= 1) will make the corresponding PORTB pin an input (i.e., put the corresponding output driver in a High-Impedance mode). Clearing a TRISB bit (= 0) will make the corresponding PORTB pin an output (i.e., enable the output driver and put the contents of the output latch on the selected pin). Example 11-1 shows how to initialize an I/O port.

Reading the PORTB register (Register 11-9) reads the status of the pins, whereas writing to it, will write to the PORT latch. All write operations are Read-Modify-Write operations. Therefore, a write to a port implies that the port pins are read, this value is modified and then written to the PORTB Data Latch (LATB).

### 11.3.2 DIRECTION CONTROL

The TRISB register (Register 11-10) controls the PORTB pin output drivers, even when they are being used as analog inputs. The user should ensure the bits in the TRISB register are maintained set when using them as analog inputs. I/O pins configured as analog inputs always read '0'.

### 11.3.3 OPEN-DRAIN CONTROL

The ODCONB register (Register 11-14) controls the open-drain feature of the port. Open-drain operation is independently selected for each pin. When an ODCONB bit is set, the corresponding port output becomes an open-drain driver, capable of sinking current only. When an ODCONB bit is cleared, the corresponding port output pin is the standard push-pull drive, capable of sourcing and sinking current.

### 11.3.4 SLEW RATE CONTROL

The SLRCONB register (Register 11-15) controls the slew rate option for each port pin. Slew rate control is independently selectable for each port pin. When an SLRCONB bit is set, the corresponding port pin drive is slew rate limited. When an SLRCONB bit is cleared, the corresponding port pin drive slews at the maximum rate possible.

### 11.3.5 INPUT THRESHOLD CONTROL

The INLVLB register (Register 11-16) controls the input voltage threshold for each of the available PORTB input pins. A selection between the Schmitt Trigger CMOS or the TTL compatible thresholds is available. The input threshold is important in determining the value of a read of the PORTB register and also the level at which an Interrupt-On-Change occurs, if that feature is enabled. See Table 36-4 for more information on threshold levels.

**Note:** Changing the input threshold selection should be performed while all peripheral modules are disabled. Changing the threshold level during the time a module is active may inadvertently generate a transition associated with an input pin, regardless of the actual voltage level on that pin.

### 11.3.6 ANALOG CONTROL

The ANSELB register (Register 11-12) is used to configure the Input mode of an I/O pin to analog. Setting the appropriate ANSELB bit high will cause all digital reads on the pin to be read as '0' and allow analog functions on the pin to operate correctly.

The state of the ANSELB bits has no effect on digital output functions. A pin with TRIS clear and the ANSELB bit set will still operate as a digital output, but the Input mode will be analog. This can cause unexpected behavior when executing Read-Modify-Write instructions on the affected port.

**Note:** The ANSELB bits default to the Analog mode after Reset. To use any pins as digital general purpose or peripheral inputs, the corresponding ANSELx bits must be initialized to '0' by user software.

### 11.3.7 PORTB FUNCTIONS AND OUTPUT PRIORITIES

Each pin defaults to the PORT latch data after Reset. Other functions are selected with the Peripheral Pin Select logic. See Section 12.0 "Peripheral Pin Select (PPS) Module" for more information. Analog input functions, such as ADC and op amp inputs, are not shown in the Peripheral Pin Select lists. These inputs are active when the I/O pin is set for Analog mode using the ANSELB register. Digital output functions may continue to control the pin when it is in Analog mode.

## 11.4 Register Definitions: PORTB

### REGISTER 11-9: PORTB: PORTB REGISTER

R/W-x/u	R/W-x/u	R/W-x/u	R/W-x/u	U-0	U-0	U-0	U-0
RB<7:4> <sup>(1)</sup>				—	—	—	—
bit 7				bit 0			

#### Legend:

R = Readable bit	W = Writable bit	
u = Bit is unchanged	x = Bit is unknown	U = Unimplemented bit, read as '0'
'1' = Bit is set	'0' = Bit is cleared	-n/n = Value at POR and BOR/Value at all other Resets

bit 7-4      **RB<7:4>**: PORTB General Purpose I/O Pin bits<sup>(1)</sup>

1 = Port pin is  $\geq$  VIH

0 = Port pin is  $\leq$  VIL

bit 3-0      **Unimplemented**: Read as '0'

**Note 1:** Writes to PORTB are actually written to the corresponding LATB register. Reads from PORTB register are the return of the actual I/O pin values.

### REGISTER 11-10: TRISB: PORTB TRI-STATE REGISTER

R/W-1/1	R/W-1/1	R/W-1/1	R/W-1/1	U-0	U-0	U-0	U-0
TRISB<7:4>				—	—	—	—
bit 7				bit 0			

#### Legend:

R = Readable bit	W = Writable bit	
u = Bit is unchanged	x = Bit is unknown	U = Unimplemented bit, read as '0'
'1' = Bit is set	'0' = Bit is cleared	-n/n = Value at POR and BOR/Value at all other Resets

bit 7-4      **TRISB<7:4>**: PORTB Tri-State Control bits

1 = PORTB pin is configured as an input (tri-stated)

0 = PORTB pin is configured as an output

bit 3-0      **Unimplemented**: Read as '0'



# PIC16(L)F1764/5/8/9

## REGISTER 11-11: LATB: PORTB DATA LATCH REGISTER

R/W-x/u	R/W-x/u	R/W-x/u	R/W-x/u	U-0	U-0	U-0	U-0
LATB<7:4> <sup>(1)</sup>				—	—	—	—
bit 7				bit 0			

### Legend:

R = Readable bit                      W = Writable bit  
 u = Bit is unchanged                x = Bit is unknown                U = Unimplemented bit, read as '0'  
 '1' = Bit is set                        '0' = Bit is cleared                -n/n = Value at POR and BOR/Value at all other Resets

bit 7-4            **LATB<7:4>**: PORTB Output Latch Value bits<sup>(1)</sup>

bit 3-0            **Unimplemented**: Read as '0'

**Note 1:** Writes to PORTB are actually written to the corresponding LATB register. Reads from PORTB register are the return of the actual I/O pin values.

## REGISTER 11-12: ANSELB: PORTB ANALOG SELECT REGISTER

R/W-1/1	R/W-1/1	R/W-1/1	R/W-1/1	U-0	U-0	U-0	U-0
ANSB<7:4>				—	—	—	—
bit 7				bit 0			

### Legend:

R = Readable bit                      W = Writable bit  
 u = Bit is unchanged                x = Bit is unknown                U = Unimplemented bit, read as '0'  
 '1' = Bit is set                        '0' = Bit is cleared                -n/n = Value at POR and BOR/Value at all other Resets

bit 7-4            **ANSB<7:4>**: Analog Select Between Analog or Digital Function on RB<7:4> Pins bits

1 = Analog input; pin is assigned as an analog input, digital input buffer is disabled<sup>(1)</sup>

0 = Digital I/O; pin is assigned to port or digital special function

bit 3-0            **Unimplemented**: Read as '0'

**Note 1:** When setting a pin to an analog input, the corresponding TRISx bit must be set to Input mode in order to allow external control of the voltage on the pin.

# PIC16(L)F1764/5/8/9

## REGISTER 11-13: WPUB: WEAK PULL-UP PORTB REGISTER

R/W-1/1	R/W-1/1	R/W-1/1	R/W-1/1	U-0	U-0	U-0	U-0
WPUB<7:4> <sup>(1,2)</sup>				—	—	—	—
bit 7				bit 0			

### Legend:

R = Readable bit	W = Writable bit	
u = Bit is unchanged	x = Bit is unknown	U = Unimplemented bit, read as '0'
'1' = Bit is set	'0' = Bit is cleared	-n/n = Value at POR and BOR/Value at all other Resets

bit 7-4      **WPUB<7:4>**: Weak Pull-up PORTB Register bits<sup>(1,2)</sup>

- 1 = Pull-up is enabled
- 0 = Pull-up is disabled

bit 3-0      **Unimplemented**: Read as '0'

- Note 1:** The global  $\overline{\text{WPUEN}}$  bit of the OPTION\_REG register must be cleared for individual pull-ups to be enabled.  
**Note 2:** The weak pull-up device is automatically disabled if the pin is configured as an output.

## REGISTER 11-14: ODCONB: PORTB OPEN-DRAIN CONTROL REGISTER

R/W-0/0	R/W-0/0	R/W-0/0	R/W-0/0	U-0	U-0	U-0	U-0
ODB<7:4>				—	—	—	—
bit 7				bit 0			

### Legend:

R = Readable bit	W = Writable bit	
u = Bit is unchanged	x = Bit is unknown	U = Unimplemented bit, read as '0'
'1' = Bit is set	'0' = Bit is cleared	-n/n = Value at POR and BOR/Value at all other Resets

bit 7-4      **ODB<7:4>**: PORTB Open-Drain Enable bits

#### For RB<7:4> Pins:

- 1 = Port pin operates as an open-drain drive (sink current only)
- 0 = Port pin operates as a standard push-pull drive (source and sink current)

bit 3-0      **Unimplemented**: Read as '0'

# PIC16(L)F1764/5/8/9

## REGISTER 11-15: SLRCONB: PORTB SLEW RATE CONTROL REGISTER

R/W-1/1	R/W-1/1	R/W-1/1	R/W-1/1	U-0	U-0	U-0	U-0
SLRB<7:4>				—	—	—	—
bit 7							bit 0

### Legend:

R = Readable bit                      W = Writable bit  
u = Bit is unchanged                  x = Bit is unknown                  U = Unimplemented bit, read as '0'  
'1' = Bit is set                            '0' = Bit is cleared                  -n/n = Value at POR and BOR/Value at all other Resets

bit 7-4            **SLRB<7:4>**: PORTB Slew Rate Enable bits

For RB<7:4> Pins:

1 = Port pin slew rate is limited

0 = Port pin slews at maximum rate

bit 3-0            **Unimplemented**: Read as '0'

## REGISTER 11-16: INLVLB: PORTB INPUT LEVEL CONTROL REGISTER

R/W-0/0	R/W-0/0	R/W-0/0	R/W-0/0	U-0	U-0	U-0	U-0
INLVLB<7:4>				—	—	—	—
bit 7							bit 0

### Legend:

R = Readable bit                      W = Writable bit  
u = Bit is unchanged                  x = Bit is unknown                  U = Unimplemented bit, read as '0'  
'1' = Bit is set                            '0' = Bit is cleared                  -n/n = Value at POR and BOR/Value at all other Resets

bit 7-4            **INLVLB<7:4>**: PORTB Input Level Select bits

For RB<7:4> Pins:

1 = Port pin digital input operates with ST thresholds

0 = Port pin digital input operates with TTL thresholds

bit 3-0            **Unimplemented**: Read as '0'

## TABLE 11-4: SUMMARY OF REGISTERS ASSOCIATED WITH PORTB

Name	Bit 7	Bit 6	Bit 5	Bit 4	Bit 3	Bit 2	Bit 1	Bit 0	Register on Page
ANSELB	ANSB<7:4>			—	—	—	—	—	145
INLVLB	INLVLB<7:4>			—	—	—	—	—	147
LATB	LATB<7:4>			—	—	—	—	—	145
ODCONB	ODB<7:4>			—	—	—	—	—	146
PORTB	RB<7:4>			—	—	—	—	—	144
SLRCONB	SLRB<7:4>			—	—	—	—	—	147
TRISB	TRISB<7:4>			—	—	—	—	—	147
WPUB	WPUB<7:4>			—	—	—	—	—	146

**Legend:** — = unimplemented location, read as '0'. Shaded cells are not used by PORTB.

## 11.5 PORTC Registers

### 11.5.1 DATA REGISTER

PORTC is a 6-bit wide bidirectional port in the PIC16(L)F1764/5 devices and 8-bit wide bidirectional port in the PIC16(L)F1768/9 devices. The corresponding Data Direction register is TRISC (Register 11-18). Setting a TRISC bit (= 1) will make the corresponding PORTC pin an input (i.e., put the corresponding output driver in a High-Impedance mode). Clearing a TRISC bit (= 0) will make the corresponding PORTC pin an output (i.e., enable the output driver and put the contents of the output latch on the selected pin). Example 11-1 shows how to initialize an I/O port.

Reading the PORTC register (Register 11-17) reads the status of the pins, whereas writing to it will write to the PORT latch. All write operations are Read-Modify-Write operations. Therefore, a write to a port implies that the port pins are read, this value is modified and then written to the PORTC Data Latch (LATC).

### 11.5.2 DIRECTION CONTROL

The TRISC register (Register 11-18) controls the PORTC pin output drivers, even when they are being used as analog inputs. The user should ensure the bits in the TRISC register are maintained set when using them as analog inputs. I/O pins configured as analog inputs always read '0'.

### 11.5.3 INPUT THRESHOLD CONTROL

The INLVLC register (Register 11-24) controls the input voltage threshold for each of the available PORTC input pins. A selection between the Schmitt Trigger CMOS or the TTL compatible thresholds is available. The input threshold is important in determining the value of a read of the PORTC register and also the level at which an Interrupt-On-Change occurs, if that feature is enabled. See Table 36-4 for more information on threshold levels.

**Note:** Changing the input threshold selection should be performed while all peripheral modules are disabled. Changing the threshold level during the time a module is active may inadvertently generate a transition associated with an input pin, regardless of the actual voltage level on that pin.

### 11.5.4 OPEN-DRAIN CONTROL

The ODCONC register (Register 11-22) controls the open-drain feature of the port. Open-drain operation is independently selected for each pin. When an ODCONC bit is set, the corresponding port output becomes an open-drain driver capable of sinking current only. When an ODCONC bit is cleared, the corresponding port output pin is the standard push-pull drive capable of sourcing and sinking current.

### 11.5.5 SLEW RATE CONTROL

The SLRCONC register (Register 11-23) controls the slew rate option for each port pin. Slew rate control is independently selectable for each port pin. When an SLRCONC bit is set, the corresponding port pin drive is slew rate limited. When an SLRCONC bit is cleared, the corresponding port pin drive slews at the maximum rate possible.

### 11.5.6 ANALOG CONTROL

The ANSEL register (Register 11-20) is used to configure the Input mode of an I/O pin to analog. Setting the appropriate ANSEL bit high will cause all digital reads on the pin to be read as '0' and allow analog functions on the pin to operate correctly.

The state of the ANSEL bits has no effect on digital output functions. A pin with TRISx clear and ANSEL set will still operate as a digital output, but the Input mode will be analog. This can cause unexpected behavior when executing Read-Modify-Write instructions on the affected port.

**Note:** The ANSEL bits default to the Analog mode after Reset. To use any pins as digital general purpose or peripheral inputs, the corresponding ANSELx bits must be initialized to '0' by user software.

### 11.5.7 PORTC FUNCTIONS AND OUTPUT PRIORITIES

Each pin defaults to the PORT latch data after Reset. Other functions are selected with the Peripheral Pin Select logic. See Section 12.0 "Peripheral Pin Select (PPS) Module" for more information.

Analog input functions, such as ADC and comparator inputs, are not shown in the Peripheral Pin Select lists. These inputs are active when the I/O pin is set for Analog mode using the ANSEL register. Digital output functions may continue to control the pin when it is in Analog mode.

### 11.5.8 HIGH-CURRENT DRIVE CONTROL

The output drivers on RC4 and RC5 are capable of sourcing and sinking up to 100 mA. This extra drive capacity can be enabled and disabled with the control bits in the HIDRVC register (Register 11-25).

## 11.6 Register Definitions: PORTC

### REGISTER 11-17: PORTC: PORTC REGISTER

R/W-x/u	R/W-x/u	R/W-x/u	R/W-x/u	R/W-x/u	R/W-x/u	R/W-x/u	R/W-x/u
RC<7:0> <sup>(1,2)</sup>							
bit 7							bit 0

#### Legend:

R = Readable bit	W = Writable bit	
u = Bit is unchanged	x = Bit is unknown	U = Unimplemented bit, read as '0'
'1' = Bit is set	'0' = Bit is cleared	-n/n = Value at POR and BOR/Value at all other Resets

bit 7-0      **RC<7:0>**: PORTC General Purpose I/O Pin bits<sup>(1,2)</sup>  
                     1 = Port pin is  $\geq$  VIH  
                     0 = Port pin is  $\leq$  VIL

**Note 1:** Writes to PORTC are actually written to corresponding LATC register. Reads from the PORTC register are the return of actual I/O pin values.

**2:** RC<7:6> are available on PIC16(L)F1768/9 only.

### REGISTER 11-18: TRISC: PORTC TRI-STATE REGISTER

R/W-1/1	R/W-1/1	R/W-1/1	R/W-1/1	R/W-1/1	R/W-1/1	R/W-1/1	R/W-1/1
TRISC<7:0> <sup>(1)</sup>							
bit 7							bit 0

#### Legend:

R = Readable bit	W = Writable bit	
u = Bit is unchanged	x = Bit is unknown	U = Unimplemented bit, read as '0'
'1' = Bit is set	'0' = Bit is cleared	-n/n = Value at POR and BOR/Value at all other Resets

bit 7-0      **TRISC<7:0>**: PORTC Tri-State Control bits<sup>(1)</sup>  
                     1 = PORTC pin is configured as an input (tri-stated)  
                     0 = PORTC pin is configured as an output

**Note 1:** TRISC<7:6> are available on PIC16(L)F1768/9 only.

## REGISTER 11-19: LATC: PORTC DATA LATCH REGISTER

R/W-x/u	R/W-x/u	R/W-x/u	R/W-x/u	R/W-x/u	R/W-x/u	R/W-x/u	R/W-x/u
LATC<7:0> <sup>(1)</sup>							
bit 7							bit 0

### Legend:

R = Readable bit	W = Writable bit	
u = Bit is unchanged	x = Bit is unknown	U = Unimplemented bit, read as '0'
'1' = Bit is set	'0' = Bit is cleared	-n/n = Value at POR and BOR/Value at all other Resets

bit 7-0      **LATC<7:0>**: PORTC Output Latch Value bits<sup>(1)</sup>

**Note 1:** LATC<7:6> are available on PIC16(L)F1768/9 only.

## REGISTER 11-20: ANSELC: PORTC ANALOG SELECT REGISTER

R/W-1/1	R/W-1/1	U-0	U-0	R/W-1/1	R/W-1/1	R/W-1/1	R/W-1/1
ANSC<7:6> <sup>(2)</sup>		—	—	ANSC<3:0>			
bit 7							bit 0

### Legend:

R = Readable bit	W = Writable bit	
u = Bit is unchanged	x = Bit is unknown	U = Unimplemented bit, read as '0'
'1' = Bit is set	'0' = Bit is cleared	-n/n = Value at POR and BOR/Value at all other Resets

bit 7-6      **ANSC<7:6>**: Analog Select Between Analog or Digital Function on RC<7:6> Pins bits<sup>(2)</sup>

- 1 = Analog input; pin is assigned as an analog input, digital input buffer is disabled<sup>(1)</sup>
- 0 = Digital I/O; pin is assigned to port or digital special function

bit 5-4      **Unimplemented:** Read as '0'

bit 3-0      **ANSC<3:0>**: Analog Select Between Analog or Digital Function on RC<3:0> Pins bits

- 1 = Analog input; pin is assigned as an analog input, digital input buffer is disabled<sup>(1)</sup>
- 0 = Digital I/O; pin is assigned to port or digital special function

**Note 1:** When setting a pin to an analog input, the corresponding TRISx bit must be set to Input mode in order to allow external control of the voltage on the pin.

**2:** ANSC<7:6> are available on PIC16(L)F1768/9 only.

## REGISTER 11-21: WPUC: WEAK PULL-UP PORTC REGISTER

R/W-1/1	R/W-1/1	R/W-1/1	R/W-1/1	R/W-1/1	R/W-1/1	R/W-1/1	R/W-1/1
WPUC<7:0> <sup>(1,2,3)</sup>							
bit 7							bit 0

### Legend:

R = Readable bit	W = Writable bit	
u = Bit is unchanged	x = Bit is unknown	U = Unimplemented bit, read as '0'
'1' = Bit is set	'0' = Bit is cleared	-n/n = Value at POR and BOR/Value at all other Resets

bit 7-0      **WPUC<7:0>**: Weak Pull-up PORTC Register bits<sup>(1,2,3)</sup>  
                   1 = Pull-up is enabled  
                   0 = Pull-up is disabled

- Note 1:** The global  $\overline{\text{WPUEN}}$  bit of the OPTION\_REG register must be cleared for individual pull-ups to be enabled.  
**Note 2:** The weak pull-up device is automatically disabled if the pin is configured as an output.  
**Note 3:** WPUC<7:6> are available on PIC16(L)F1768/9 only.

## REGISTER 11-22: ODCONC: PORTC OPEN-DRAIN CONTROL REGISTER

R/W-0/0	R/W-0/0	R/W-0/0	R/W-0/0	R/W-0/0	R/W-0/0	R/W-0/0	R/W-0/0
ODC<7:0> <sup>(1)</sup>							
bit 7							bit 0

### Legend:

R = Readable bit	W = Writable bit	
u = Bit is unchanged	x = Bit is unknown	U = Unimplemented bit, read as '0'
'1' = Bit is set	'0' = Bit is cleared	-n/n = Value at POR and BOR/Value at all other Resets

bit 7-0      **ODC<7:0>**: PORTC Open-Drain Enable bits<sup>(1)</sup>  
                   For RC<7:0> Pins:  
                   1 = Port pin operates as an open-drain drive (sink current only)  
                   0 = Port pin operates as a standard push-pull drive (source and sink current)

- Note 1:** ODC<7:6> are available on PIC16(L)F1768/9 only.

## REGISTER 11-23: SLRCONC: PORTC SLEW RATE CONTROL REGISTER

R/W-1/1	R/W-1/1	R/W-1/1	R/W-1/1	R/W-1/1	R/W-1/1	R/W-1/1	R/W-1/1
SLRC<7:0> <sup>(1)</sup>							
bit 7							bit 0

### Legend:

R = Readable bit	W = Writable bit	
u = Bit is unchanged	x = Bit is unknown	U = Unimplemented bit, read as '0'
'1' = Bit is set	'0' = Bit is cleared	-n/n = Value at POR and BOR/Value at all other Resets

bit 7-0      **SLRC<7:0>**: PORTC Slew Rate Enable bits<sup>(1)</sup>

For RC<7:0> Pins:

- 1 = Port pin slew rate is limited
- 0 = Port pin slews at maximum rate

**Note 1:** SLRC<7:6> are available on PIC16(L)F1768/9 only.

## REGISTER 11-24: INLVLC: PORTC INPUT LEVEL CONTROL REGISTER

R/W-1/1	R/W-1/1	R/W-1/1	R/W-1/1	R/W-1/1	R/W-1/1	R/W-1/1	R/W-1/1
INLVLC<7:0> <sup>(1)</sup>							
bit 7							bit 0

### Legend:

R = Readable bit	W = Writable bit	
u = Bit is unchanged	x = Bit is unknown	U = Unimplemented bit, read as '0'
'1' = Bit is set	'0' = Bit is cleared	-n/n = Value at POR and BOR/Value at all other Resets

bit 7-0      **INLVLC<7:0>**: PORTC Input Level Select bits<sup>(1)</sup>

For RC<7:0> Pins:

- 1 = Port pin digital input operates with ST thresholds
- 0 = Port pin digital input operates with TTL thresholds

**Note 1:** INLVLC<7:6> are available on PIC16(L)F1768/9 only.



# PIC16(L)F1764/5/8/9

**REGISTER 11-25: HIDRVC: PORTC HIGH DRIVE CONTROL REGISTER**

U-0	U-0	R/W-0/0	R/W-0/0	U-0	U-0	U-0	U-0
—	—	HIDC<5:4>		—	—	—	—
bit 7							bit 0

**Legend:**

R = Readable bit                      W = Writable bit  
u = Bit is unchanged                  x = Bit is unknown                  U = Unimplemented bit, read as '0'  
'1' = Bit is set                            '0' = Bit is cleared                  -n/n = Value at POR and BOR/Value at all other Resets

bit 7-6            **Unimplemented:** Read as '0'  
bit 5-4            **HIDC<5:4>:** PORTC High Drive Enable bits  
                    For RC<5:4> Pins:  
                    1 = High-current source and sink are enabled  
                    0 = Standard current source and sink  
bit 3-0            **Unimplemented:** Read as '0'

**TABLE 11-5: SUMMARY OF REGISTERS ASSOCIATED WITH PORTC**

Name	Bit 7	Bit 6	Bit 5	Bit 4	Bit 3	Bit 2	Bit 1	Bit 0	Register on Page
ANSEL	ANSC<7:6> <sup>(1)</sup>		—	—	ANSC<3:0>				150
HIDRVC	—	—	HIDC<5:4>		—	—	—		153
INLVLC	INLVLC<7:0> <sup>(1)</sup>								152
LATC	LATC<7:0> <sup>(1)</sup>								150
ODCONC	ODC<7:0> <sup>(1)</sup>								151
PORTC	RC<7:0> <sup>(1)</sup>								149
SLRCONC	SLRC<7:0> <sup>(1)</sup>								152
TRISC	TRISC<7:0> <sup>(1)</sup>								149
WPUC	WPUC<7:0> <sup>(1)</sup>								151

**Legend:** — = unimplemented location, read as '0'. Shaded cells are not used by PORTC.

**Note 1:** Bits<7:6> are available on PIC16(L)F1768/9 only.

## 12.0 PERIPHERAL PIN SELECT (PPS) MODULE

The Peripheral Pin Select (PPS) module connects peripheral inputs and outputs to the device I/O pins. Only digital signals are included in the selections. All analog inputs and outputs remain fixed to their assigned pins. Input and output selections are independent, as shown in the simplified block diagram (Figure 12-1).

The peripheral input is selected with the xxxPPS register (Register 12-1) and the peripheral output is selected with the RxyPPS register (Register 12-2). For example, to select PORTB, bit 7 (RB7) as the EUSART RX input, set RxyPPS<4:0> to '01111' and to select PORTB, bit 6 (RB6) as the TX output, set RxyPPS<4:0> to '10110'.

### 12.1 PPS Inputs

Each peripheral has a PPS register with which the inputs to the peripheral are selected. Inputs include the device pins.

Multiple peripherals can operate from the same source simultaneously. Port reads always return the pin level, regardless of the peripheral PPS selection. If a pin also has associated analog functions, the ANSELx bit for that pin must be cleared to enable the digital input buffer.

Although every peripheral has its own PPS Input Selection register, the selections are identical for every peripheral, as shown in Register 12-1.

**Note:** The notation, "xxx", in the register name is a placeholder for the peripheral identifier. For example, CLC1PPS represents the PPS Input Selection register for the CLC1 peripheral.

### 12.2 PPS Outputs

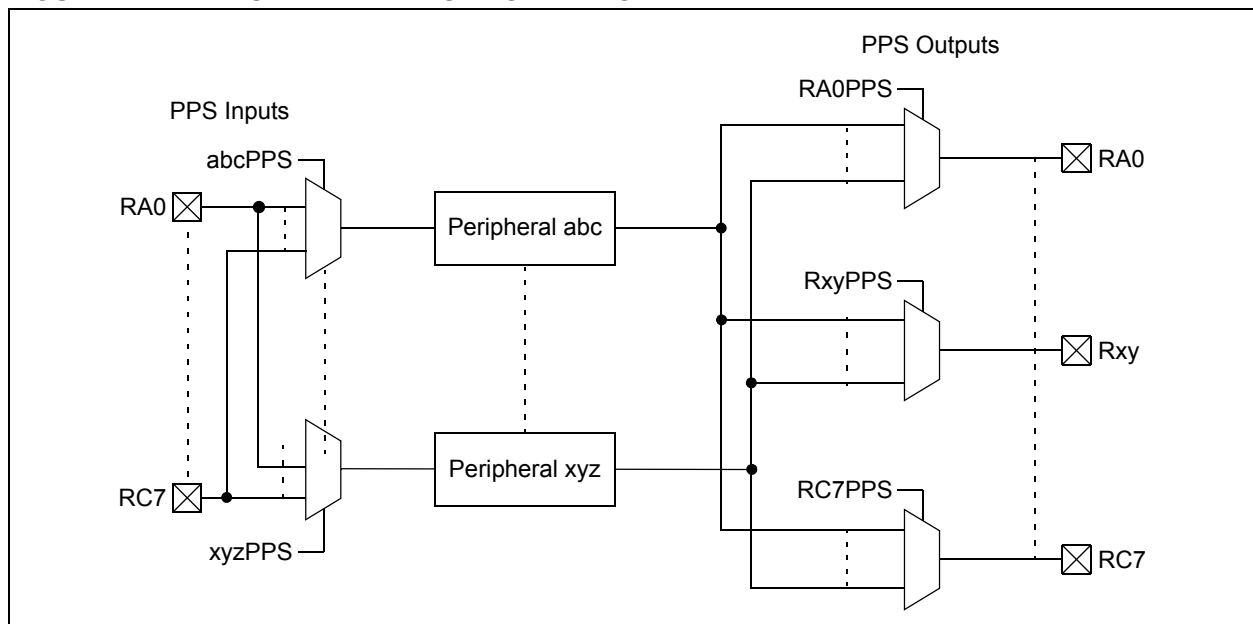
Each I/O pin has a PPS register with which the pin output source is selected. With few exceptions, the port TRISx control associated with that pin retains control over the pin output driver. Peripherals that control the pin output driver as part of the peripheral operation will override the TRISx control as needed. These peripherals include:

- EUSART (synchronous operation)
- MSSP (I<sup>2</sup>C)
- COG (auto-shutdown)

Although every pin has its own PPS Peripheral Selection register, the selections are identical for every pin, as shown in Register 12-2.

**Note:** The notation, "Rxy", is a placeholder for the pin port and bit identifiers. For example, x and y for PORTA, bit 0 would be A and 0, respectively, resulting in the PPS Pin Output Source Selection register, RA0PPS.

**FIGURE 12-1: SIMPLIFIED PPS BLOCK DIAGRAM**



## 12.3 Bidirectional Pins

PPS selections for peripherals with bidirectional signals on a single pin must be made so that the PPS input and PPS output select the same pin. Peripherals that have bidirectional signals include:

- EUSART (synchronous operation)
- MSSP (I<sup>2</sup>C)

**Note:** The I<sup>2</sup>C default input pins are I<sup>2</sup>C and SMBus compatible, and are the only pins on the device with this compatibility.

## 12.4 PPS Lock

The PPS includes a mode in which all input and output selections can be locked to prevent inadvertent changes. PPS selections are locked by setting the PPSLOCKED bit of the PPSLOCK register. Setting and clearing this bit requires a special sequence as an extra precaution against inadvertent changes. Examples of setting and clearing the PPSLOCKED bit are shown in [Example 12-1](#).

### EXAMPLE 12-1: PPS LOCK/UNLOCK SEQUENCE

```
; suspend interrupts
    bcf    INTCON,GIE
; BANKSEL PPSLOCK    ; set bank
; required sequence, next 5 instructions
    movlw 0x55
    movwf PPSLOCK
    movlw 0xAA
    movwf PPSLOCK
; Set PPSLOCKED bit to disable writes or
; Clear PPSLOCKED bit to enable writes
    bsf    PPSLOCK,PPSLOCKED
; restore interrupts
    bsf    INTCON,GIE
```

## 12.5 PPS Permanent Lock

The PPS can be permanently locked by setting the PPS1WAY Configuration bit. When this bit is set, the PPSLOCKED bit can only be cleared and set one time after a device Reset. This allows for clearing the PPSLOCKED bit so that the input and output selections can be made during initialization. When the PPSLOCKED bit is set, after all selections have been made, it will remain set and cannot be cleared until after the next device Reset event.

## 12.6 Operation During Sleep

PPS input and output selections are unaffected by Sleep.

## 12.7 Effects of a Reset

A device Power-on Reset (POR) clears all PPS input and output selections to their default values. All other Resets leave the selections unchanged. Default input selections are shown in [Table 12-1](#).

## 12.8 Register Definitions: PPS Input and Output Selections

**REGISTER 12-1: xxxPPS: PERIPHERAL xxx INPUT SELECTION**

U-0	U-0	U-0	R/W-q/u	R/W-q/u	R/W-q/u	R/W-q/u	R/W-q/u
—	—	—	xxxPPS<4:3>		xxxPPS<2:0> <sup>(1)</sup>		
bit 7							bit 0

**Legend:**

R = Readable bit	W = Writable bit	U = Unimplemented bit, read as '0'
u = Bit is unchanged	x = Bit is unknown	-n/n = Value at POR and BOR/Value at all other Resets
'1' = Bit is set	'0' = Bit is cleared	q = value depends on peripheral

- bit 7-5      **Unimplemented:** Read as '0'
- bit 4-3      **xxxPPS<4:3>:** Peripheral xxx Input PORT Selection bits  
                  11 = Reserved; do not use  
                  10 = Peripheral input is PORTC  
                  01 = Peripheral input is PORTB<sup>(2)</sup>  
                  00 = Peripheral input is PORTA
- bit 2-0      **xxxPPS<2:0>:** Peripheral xxx Input Bit Selection bits<sup>(1)</sup>  
                  111 = Peripheral input is from PORTx, bit 7 (Rx7)  
                  110 = Peripheral input is from PORTx, bit 6 (Rx6)  
                  101 = Peripheral input is from PORTx, bit 5 (Rx5)  
                  100 = Peripheral input is from PORTx, bit 4 (Rx4)  
                  011 = Peripheral input is from PORTx, bit 3 (Rx3)  
                  010 = Peripheral input is from PORTx, bit 2 (Rx2)  
                  001 = Peripheral input is from PORTx, bit 1 (Rx1)  
                  000 = Peripheral input is from PORTx, bit 0 (Rx0)

- Note 1:** See [Table 12-1](#) for xxxPPS register list and Reset values.  
**Note 2:** PIC16(L)F1768/9 only.

**REGISTER 12-2: RxyPPS: PIN Rxy OUTPUT SOURCE SELECTION REGISTER**

U-0	U-0	U-0	R/W-0/u	R/W-0/u	R/W-0/u	R/W-0/u	R/W-0/u
—	—	—	RxyPPS<4:0>				
bit 7							bit 0

**Legend:**

R = Readable bit	W = Writable bit	U = Unimplemented bit, read as '0'
u = Bit is unchanged	x = Bit is unknown	-n/n = Value at POR and BOR/Value at all other Resets
'1' = Bit is set	'0' = Bit is cleared	

- bit 7-5      **Unimplemented:** Read as '0'
- bit 4-0      **RxyPPS<4:0>:** Pin Rxy Output Source Selection bits  
                  Selection code determines the output signal on the port pin. See [Table 12-2](#) for the selection codes.

## REGISTER 12-3: PPSLOCK: PPS LOCK REGISTER

U-0	U-0	U-0	U-0	U-0	U-0	U-0	R/W-0/0
—	—	—	—	—	—	—	PPSLOCKED
bit 7							bit 0

### Legend:

R = Readable bit

W = Writable bit

u = Bit is unchanged

x = Bit is unknown

U = Unimplemented bit, read as '0'

'1' = Bit is set

'0' = Bit is cleared

-n/n = Value at POR and BOR/Value at all other Resets

bit 7-1

**Unimplemented:** Read as '0'

bit 0

**PPSLOCKED:** PPS Locked bit

1 = PPS is locked; PPS selections cannot be changed

0 = PPS is not locked; PPS selections can be changed

**TABLE 12-1: PPS INPUT REGISTER RESET VALUES**

Peripheral	xxxPPS Register (Register 12-1)	Default Pin Selection		Reset Value (xxxPPS<4:0>)	
		PIC16(L)F1768/9	PIC16(L)F1764/5	PIC16(L)F1768/9	PIC16(L)F1764/5
Interrupt-On-Change	INTPPS	RA2	RA2	00010	00010
Timer0 Clock	T0CKIPPS	RA2	RA2	00010	00010
Timer1 Clock	T1CKIPPS	RA5	RA5	00101	00101
Timer1 Gate	T1GPPS	RA4	RA4	00100	00100
Timer2 Clock	T2INPPS	RA5	RA5	0101	0101
Timer3 Clock	T3CKIPPS	RC5	RC5	10101	10101
Timer3 Gate	T3GPPS	RC4	RC4	10100	10100
Timer4 Clock	T4INPPS	RC1	RC1	10001	10001
Timer5 Clock	T5CKIPPS	RC0	RC0	10000	10000
Timer5 Gate	T5GPPS	RC3	RC3	10011	10011
Timer6 Clock	T6INPPS	RA3	RA3	00011	00011
CCP1	CCP1PPS	RC5	RC5	10101	10101
CCP2	CCP2PPS <sup>(1)</sup>	RC3	—	10011	—
COG1	COG1INPPS	RA2	RA2	00010	00010
COG2	COG2INPPS <sup>(1)</sup>	RA2	—	00010	—
SPI and I <sup>2</sup> C Clock	SSPCLKPPS	RB6	RC0	01110	10000
SPI and I <sup>2</sup> C Data	SSPDATPPS	RB4	RC1	01100	10001
SPI Slave Select	SSPSSPPS	RC6	RC3	10110	10011
EUSART RX	RXPPS	RB5	RC5	01101	10101
EUSART CK	CKPPS	RB7	RC4	01111	10100
All CLCs	CLCIN0PPS	RC3	RC3	10011	10011
All CLCs	CLCIN1PPS	RC4	RC4	10100	10100
All CLCs	CLCIN2PPS	RC1	RC1	10001	10001
All CLCs	CLCIN3PPS	RA5	RA5	00101	00101
PRG1 Set Rising	PRG1RPPS	RC4	RC4	10100	10100
PRG1 Set Falling	PRG1FPPS	RC5	RC5	10101	10101
PRG2 Set Rising	PRG2RPPS <sup>(1)</sup>	RC4	—	10100	—
PRG2 Set Falling	PRG2FPPS <sup>(1)</sup>	RC5	—	10101	—
DSM1 High Carrier	MD1CHPPS	RA3	RA3	00011	00011
DSM1 Low Carrier	MD1CLPPS	RA4	RA4	00100	00100
DSM1 Modulation	MD1MODPPS	RA5	RA5	00101	00101
DSM2 High Carrier	MD2CHPPS <sup>(1)</sup>	RA3	—	00011	—
DSM2 Low Carrier	MD2CLPPS <sup>(1)</sup>	RA4	—	00100	—
DSM2 Modulation	MD2MODPPS <sup>(1)</sup>	RA5	—	00101	—

**Example:** CCP1PPS = 0x13 selects RC3 as the CCP1 input.

**Note 1:** PIC16(L)F1768/9 only.

# PIC16(L)F1764/5/8/9

**TABLE 12-2: AVAILABLE PORTS FOR OUTPUT BY PERIPHERAL<sup>(2)</sup>**

RxyPPS<4:0>	Output Signal	PIC16(L)F1768/9			PIC16(L)F1764/5	
		PORTA	PORTB	PORTC	PORTA	PORTC
1111x	Reserved	—	—	—	—	—
11101	MD2_out	•	•	•	—	—
11100	MD1_out	•	•	•	•	•
11011	sync_C4OUT	•	•	•	—	—
11010	sync_C3OUT	•	•	•	—	—
11001	sync_C2OUT	•	•	•	•	•
11000	sync_C1OUT	•	•	•	•	•
10111	DT <sup>(1)</sup>	•	•	•	•	•
10110	TX/CK <sup>(1)</sup>	•	•	•	•	•
10101	Reserved	—	—	—	—	—
10100	SDO	•	•	•	•	•
10011	SDA	•	•	•	•	•
10010	SCK/SCL <sup>(1)</sup>	•	•	•	•	•
10001	PWM6_out	•	•	•	—	—
10000	PWM5_out	•	•	•	•	•
01111	PWM4_out	•	•	•	—	—
01110	PWM3_out	•	•	•	•	•
01101	CCP2_out	•	•	•	•	•
01100	CCP1_out	•	•	•	•	•
01011	COG2D <sup>(1)</sup>	•	•	•	—	—
01010	COG2C <sup>(1)</sup>	•	•	•	—	—
01001	COG2B <sup>(1)</sup>	•	•	•	—	—
01000	COG2A <sup>(1)</sup>	•	•	•	—	—
00111	COG1D <sup>(1)</sup>	•	•	•	•	•
00110	COG1C <sup>(1)</sup>	•	•	•	•	•
00101	COG1B <sup>(1)</sup>	•	•	•	•	•
00100	COG1A <sup>(1)</sup>	•	•	•	•	•
00011	LC3_out	•	•	•	•	•
00010	LC2_out	•	•	•	•	•
00001	LC1_out	•	•	•	•	•
00000	LATxy	•	•	•	•	•

**Note 1:** TRISx control is overridden by the peripheral as required.

**2:** Unsupported peripherals will output a 0.

# PIC16(L)F1764/5/8/9

**TABLE 12-3: SUMMARY OF REGISTERS ASSOCIATED WITH THE PPS MODULE**

Name	Bit 7	Bit 6	Bit 5	Bit 4	Bit 3	Bit 2	Bit 1	Bit 0	Register on Page
PPSLOCK	—	—	—	—	—	—	—	PPSLOCKED	157
INTPPS	—	—	—	INTPPS<4:0>					156
T0CKIPPS	—	—	—	T0CKIPPS<4:0>					156
T1CKIPPS	—	—	—	T1CKIPPS<4:0>					156
T1GPPS	—	—	—	T1GPPS<4:0>					156
T2INPPS	—	—	—	T2INPPS<4:0>					156
T3CKIPPS	—	—	—	T3CKIPPS<4:0>					156
T3GPPS	—	—	—	T3GPPS<4:0>					156
T4INPPS	—	—	—	T4INPPS<4:0>					156
T5CKIPPS	—	—	—	T5CKIPPS<4:0>					156
T5GPPS	—	—	—	T5GPPS<4:0>					156
T6INPPS	—	—	—	T6INPPS<4:0>					156
CCP1PPS	—	—	—	CCP1PPS<4:0>					156
CCP2PPS <sup>(1)</sup>	—	—	—	CCP2PPS<4:0>					156
COG1INPPS	—	—	—	COG1INPPS<4:0>					156
COG2INPPS <sup>(1)</sup>	—	—	—	COG2INPPS<4:0>					156
SSPCLKPPS	—	—	—	SSPCLKPPS<4:0>					156
SSPDATPPS	—	—	—	SSPDATPPS<4:0>					156
SSPSSPPS	—	—	—	SSPSSPPS<4:0>					156
RXPPS	—	—	—	RXPPS<4:0>					156
CKPPS	—	—	—	CKPPS<4:0>					156
CLCIN0PPS	—	—	—	CLCIN0PPS<4:0>					156
CLCIN1PPS	—	—	—	CLCIN1PPS<4:0>					156
CLCIN2PPS	—	—	—	CLCIN2PPS<4:0>					156
CLCIN3PPS	—	—	—	CLCIN3PPS<4:0>					156
PRG1RPPS	—	—	—	PRG1RPPS<4:0>					156
PRG1FPPS	—	—	—	PRG1FPPS<4:0>					156
PRG2RPPS <sup>(1)</sup>	—	—	—	PRG2RPPS<4:0>					156
PRG2FPPS <sup>(1)</sup>	—	—	—	PRG2FPPS<4:0>					156
MD1CHPPS	—	—	—	MD1CHPPS<4:0>					156
MD1CLPPS	—	—	—	MD1CLPPS<4:0>					156
MD1MODPPS	—	—	—	MD1MODPPS<4:0>					156
MD2CHPPS <sup>(1)</sup>	—	—	—	MD2CHPPS<4:0>					156
MD2CLPPS <sup>(1)</sup>	—	—	—	MD2CLPPS<4:0>					156
MD2MODPPS <sup>(1)</sup>	—	—	—	MD2MODPPS<4:0>					156
RA0PPS	—	—	—	RA0PPS<4:0>					156
RA1PPS	—	—	—	RA1PPS<4:0>					156
RA2PPS	—	—	—	RA2PPS<4:0>					156
RA4PPS	—	—	—	RA4PPS<4:0>					156
RA5PPS	—	—	—	RA5PPS<4:0>					156
RB4PPS <sup>(1)</sup>	—	—	—	RB4PPS<4:0>					156

**Legend:** — = unimplemented, read as '0'. Shaded cells are unused by the PPS module.

**Note 1:** PIC16(L)F1768/9 only.



# PIC16(L)F1764/5/8/9

**TABLE 12-3: SUMMARY OF REGISTERS ASSOCIATED WITH THE PPS MODULE (CONTINUED)**

Name	Bit 7	Bit 6	Bit 5	Bit 4	Bit 3	Bit 2	Bit 1	Bit 0	Register on Page
RB5PPS <sup>(1)</sup>	—	—	—					RB5PPS<4:0>	<a href="#">156</a>
RB6PPS <sup>(1)</sup>	—	—	—					RB6PPS<4:0>	<a href="#">156</a>
RB7PPS <sup>(1)</sup>	—	—	—					RB7PPS<4:0>	<a href="#">156</a>
RC0PPS	—	—	—					RC0PPS<4:0>	<a href="#">156</a>
RC1PPS	—	—	—					RC1PPS<4:0>	<a href="#">156</a>
RC2PPS	—	—	—					RC2PPS<4:0>	<a href="#">156</a>
RC3PPS	—	—	—					RC3PPS<4:0>	<a href="#">156</a>
RC4PPS	—	—	—					RC4PPS<4:0>	<a href="#">156</a>
RC5PPS	—	—	—					RC5PPS<4:0>	<a href="#">156</a>
RC6PPS <sup>(1)</sup>	—	—	—					RC6PPS<4:0>	<a href="#">156</a>
RC7PPS <sup>(1)</sup>	—	—	—					RC7PPS<4:0>	<a href="#">156</a>

**Legend:** — = unimplemented, read as '0'. Shaded cells are unused by the PPS module.

**Note 1:** PIC16(L)F1768/9 only.

## 13.0 INTERRUPT-ON-CHANGE

All pins on all ports can be configured to operate as Interrupt-On-Change (IOC) pins. An interrupt can be generated by detecting a signal that has either a rising edge or a falling edge. Any individual pin, or combination of pins, can be configured to generate an interrupt. The Interrupt-On-Change module has the following features:

- Interrupt-On-Change enable (Master Switch)
- Individual pin configuration
- Rising and falling edge detection
- Individual pin interrupt flags

Figure 13-1 is a block diagram of the IOC module.

### 13.1 Enabling the Module

To allow individual pins to generate an interrupt, the IOCIE bit of the INTCON register must be set. If the IOCIE bit is disabled, the edge detection on the pin will still occur, but an interrupt will not be generated.

### 13.2 Individual Pin Configuration

For each pin, a rising edge detector and a falling edge detector are present. To enable a pin to detect a rising edge, the associated bit of the IOCxP register is set. To enable a pin to detect a falling edge, the associated bit of the IOCxN register is set.

A pin can be configured to detect rising and falling edges simultaneously by setting the associated bits in both of the IOCxP and IOCxN registers.

## 13.3 Interrupt Flags

The bits located in the IOCxF registers are status flags that correspond to the Interrupt-On-Change pins of each port. If an expected edge is detected on an appropriately enabled pin, then the status flag for that pin will be set and an interrupt will be generated if the IOCIE bit is set. The IOCIF bit of the INTCON register reflects the status of all IOCxF bits.

### 13.4 Clearing Interrupt Flags

The individual status flags (IOCxF register bits) can be cleared by resetting them to zero. If another edge is detected during this clearing operation, the associated status flag will be set at the end of the sequence, regardless of the value actually being written.

In order to ensure that no detected edge is lost while clearing flags, only AND operations masking out known changed bits should be performed. The following sequence is an example of what should be performed.

#### EXAMPLE 13-1: CLEARING INTERRUPT FLAGS (PORTA EXAMPLE)

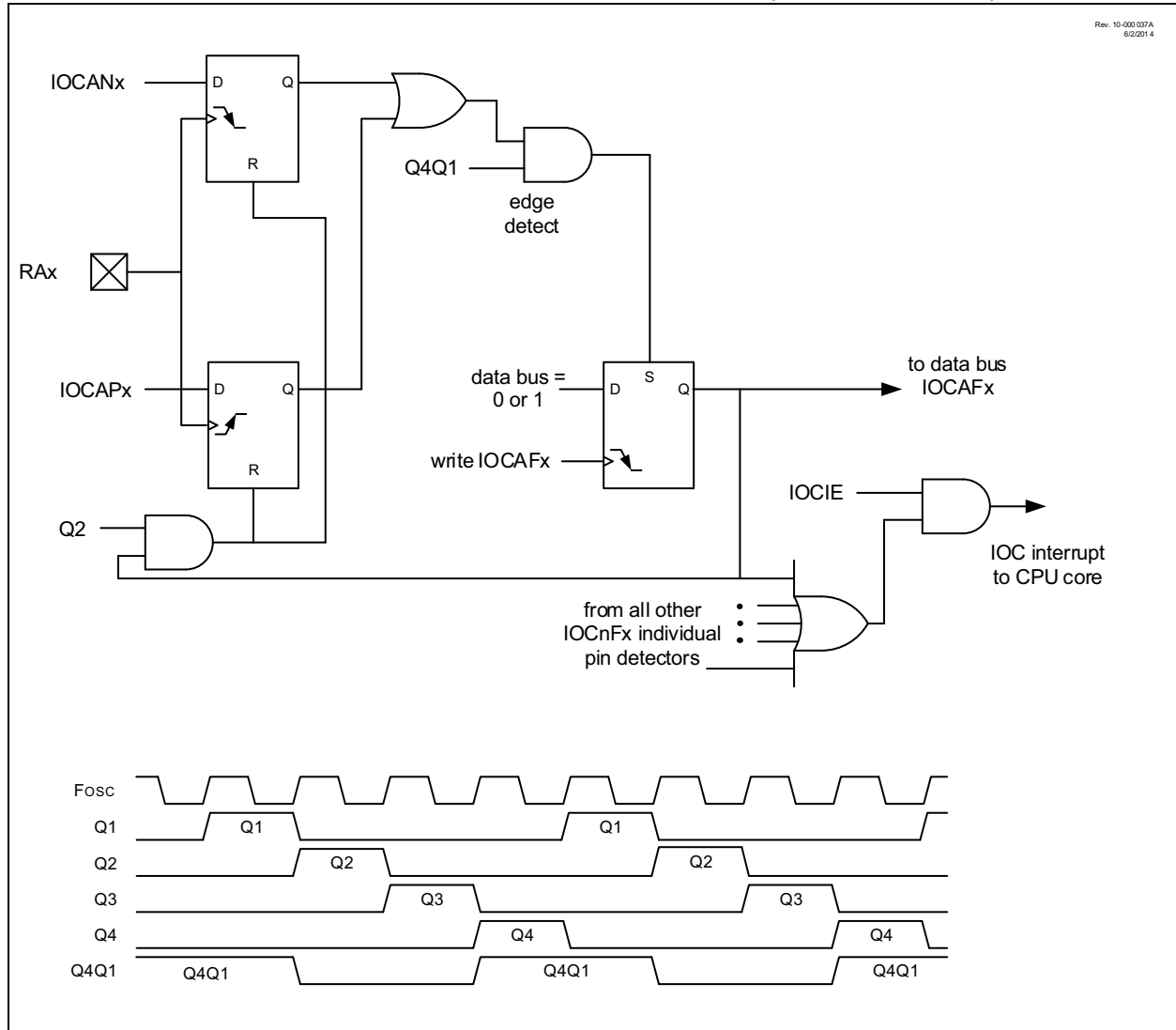
```
MOVLW  0xff
XORWF  IOCAF, W
ANDWF  IOCAF, F
```

### 13.5 Operation in Sleep

The Interrupt-On-Change interrupt sequence will wake the device from Sleep mode if the IOCIE bit is set.

If an edge is detected while in Sleep mode, the affected IOCxF register will be updated prior to the first instruction executed out of Sleep.

**FIGURE 13-1: INTERRUPT-ON-CHANGE BLOCK DIAGRAM (PORTA EXAMPLE)**



## 13.6 Register Definitions: Interrupt-On-Change Control

### REGISTER 13-1: IOCAP: INTERRUPT-ON-CHANGE PORTA POSITIVE EDGE REGISTER

U-0	U-0	R/W-0/0	R/W-0/0	R/W-0/0	R/W-0/0	R/W-0/0	R/W-0/0
—	—	IOCAP<5:0>					
bit 7							bit 0

**Legend:**

R = Readable bit	W = Writable bit	
u = Bit is unchanged	x = Bit is unknown	U = Unimplemented bit, read as '0'
'1' = Bit is set	'0' = Bit is cleared	-n/n = Value at POR and BOR/Value at all other Resets

bit 7-6 **Unimplemented:** Read as '0'

bit 5-0 **IOCAP<5:0>:** Interrupt-On-Change PORTA Positive Edge Enable bits

1 = Interrupt-On-Change is enabled on the pin for a positive going edge; IOCAF<sub>x</sub> bit and IOCIF flag will be set upon edge detection

0 = Interrupt-On-Change is disabled for the associated pin

### REGISTER 13-2: IOCAN: INTERRUPT-ON-CHANGE PORTA NEGATIVE EDGE REGISTER

U-0	U-0	R/W-0/0	R/W-0/0	R/W-0/0	R/W-0/0	R/W-0/0	R/W-0/0
—	—	IOCAN<5:0>					
bit 7							bit 0

**Legend:**

R = Readable bit	W = Writable bit	
u = Bit is unchanged	x = Bit is unknown	U = Unimplemented bit, read as '0'
'1' = Bit is set	'0' = Bit is cleared	-n/n = Value at POR and BOR/Value at all other Resets

bit 7-6 **Unimplemented:** Read as '0'

bit 5-0 **IOCAN<5:0>:** Interrupt-On-Change PORTA Negative Edge Enable bits

1 = Interrupt-On-Change is enabled on the pin for a negative going edge; IOCAF<sub>x</sub> bit and IOCIF flag will be set upon edge detection

0 = Interrupt-On-Change is disabled for the associated pin

# PIC16(L)F1764/5/8/9

## REGISTER 13-3: IOCAF: INTERRUPT-ON-CHANGE PORTA FLAG REGISTER

U-0	U-0	R/W/HS-0/0	R/W/HS-0/0	R/W/HS-0/0	R/W/HS-0/0	R/W/HS-0/0	R/W/HS-0/0
—	—	IOCAF<5:0>					
bit 7							bit 0

### Legend:

R = Readable bit	W = Writable bit	U = Unimplemented bit, read as '0'
u = Bit is unchanged	x = Bit is unknown	-n/n = Value at POR and BOR/Value at all other Resets
'1' = Bit is set	'0' = Bit is cleared	HS = Hardware Settable bit

bit 7-6 **Unimplemented:** Read as '0'

bit 5-0 **IOCAF<5:0>:** Interrupt-On-Change PORTA Flag bits

1 = An enabled change was detected on the associated pin

Set when IOCAPx = 1 and a rising edge was detected on RAX, or when IOCANx = 1 and a falling edge was detected on RAX.

0 = No change was detected or the user cleared the detected change

## REGISTER 13-4: IOCBP: INTERRUPT-ON-CHANGE PORTB POSITIVE EDGE REGISTER<sup>(1)</sup>

R/W-0/0	R/W-0/0	R/W-0/0	R/W-0/0	U-0	U-0	U-0	U-0
IOCBP<7:4>				—	—	—	—
bit 7							bit 0

### Legend:

R = Readable bit	W = Writable bit	U = Unimplemented bit, read as '0'
u = Bit is unchanged	x = Bit is unknown	-n/n = Value at POR and BOR/Value at all other Resets
'1' = Bit is set	'0' = Bit is cleared	

bit 7-4 **IOCBP<7:4>:** Interrupt-On-Change PORTB Positive Edge Enable bits

1 = Interrupt-On-Change is enabled on the pin for a positive going edge; IOCBFx bit and IOCIF flag will be set upon edge detection

0 = Interrupt-On-Change is disabled for the associated pin

bit 3-0 **Unimplemented:** Read as '0'

**Note 1:** PIC16(L)F1768/9 only.

# PIC16(L)F1764/5/8/9

**REGISTER 13-5: IOCBN: INTERRUPT-ON-CHANGE PORTB NEGATIVE EDGE REGISTER<sup>(1)</sup>**

R/W-0/0	R/W-0/0	R/W-0/0	R/W-0/0	U-0	U-0	U-0	U-0
IOCBN<7:4>				—	—	—	—
bit 7				bit 0			

**Legend:**

R = Readable bit	W = Writable bit	
u = Bit is unchanged	x = Bit is unknown	U = Unimplemented bit, read as '0'
'1' = Bit is set	'0' = Bit is cleared	-n/n = Value at POR and BOR/Value at all other Resets

- bit 7-4      **IOCBN<7:4>**: Interrupt-On-Change PORTB Negative Edge Enable bits  
 1 = Interrupt-On-Change is enabled on the pin for a negative going edge; IOCBFx bit and IOCIF flag will be set upon edge detection  
 0 = Interrupt-On-Change is disabled for the associated pin
- bit 3-0      **Unimplemented**: Read as '0'

**Note 1:** PIC16(L)F1768/9 only.

**REGISTER 13-6: IOCBF: INTERRUPT-ON-CHANGE PORTB FLAG REGISTER<sup>(1)</sup>**

R/W/HS-0/0	R/W/HS-0/0	R/W/HS-0/0	R/W/HS-0/0	U-0	U-0	U-0	U-0
IOCBF<7:4>				—	—	—	—
bit 7				bit 0			

**Legend:**

R = Readable bit	W = Writable bit	U = Unimplemented bit, read as '0'
u = Bit is unchanged	x = Bit is unknown	-n/n = Value at POR and BOR/Value at all other Resets
'1' = Bit is set	'0' = Bit is cleared	HS = Hardware Settable bit

- bit 7-4      **IOCBF<7:4>**: Interrupt-On-Change PORTB Flag bits  
 1 = An enabled change was detected on the associated pin  
     Set when IOCBPx = 1 and a rising edge was detected on RBx, or when IOCBNx = 1 and a falling edge was detected on RBx.  
 0 = No change was detected or the user cleared the detected change
- bit 3-0      **Unimplemented**: Read as '0'

**Note 1:** PIC16(L)F1768/9 only.

# PIC16(L)F1764/5/8/9

## REGISTER 13-7: IOCCP: INTERRUPT-ON-CHANGE PORTC POSITIVE EDGE REGISTER

R/W-0/0	R/W-0/0	R/W-0/0	R/W-0/0	R/W-0/0	R/W-0/0	R/W-0/0	R/W-0/0
IOCCP<7:0> <sup>(1)</sup>							
bit 7							bit 0

### Legend:

R = Readable bit	W = Writable bit	
u = Bit is unchanged	x = Bit is unknown	U = Unimplemented bit, read as '0'
'1' = Bit is set	'0' = Bit is cleared	-n/n = Value at POR and BOR/Value at all other Resets

bit 7-0      **IOCCP<7:0>**: Interrupt-On-Change PORTC Positive Edge Enable bits<sup>(1)</sup>  
1 = Interrupt-On-Change is enabled on the pin for a positive going edge; IOCCFx bit and IOCIF flag will be set upon edge detection  
0 = Interrupt-On-Change is disabled for the associated pin

**Note 1:** Bits<7:6> are available on PIC16(L)F1768/9 only.

## REGISTER 13-8: IOCCN: INTERRUPT-ON-CHANGE PORTC NEGATIVE EDGE REGISTER

R/W-0/0	R/W-0/0	R/W-0/0	R/W-0/0	R/W-0/0	R/W-0/0	R/W-0/0	R/W-0/0
IOCCN<7:0> <sup>(1)</sup>							
bit 7							bit 0

### Legend:

R = Readable bit	W = Writable bit	
u = Bit is unchanged	x = Bit is unknown	U = Unimplemented bit, read as '0'
'1' = Bit is set	'0' = Bit is cleared	-n/n = Value at POR and BOR/Value at all other Resets

bit 7-0      **IOCCN<7:0>**: Interrupt-On-Change PORTC Negative Edge Enable bits<sup>(1)</sup>  
1 = Interrupt-On-Change is enabled on the pin for a negative going edge; IOCCFx bit and IOCIF flag will be set upon edge detection  
0 = Interrupt-On-Change is disabled for the associated pin

**Note 1:** Bits<7:6> are available on PIC16(L)F1768/9 only.

# PIC16(L)F1764/5/8/9

## REGISTER 13-9: IOCCF: INTERRUPT-ON-CHANGE PORTC FLAG REGISTER

R/W/HS-0/0	R/W/HS-0/0	R/W/HS-0/0	R/W/HS-0/0	R/W/HS-0/0	R/W/HS-0/0	R/W/HS-0/0	R/W/HS-0/0
IOCCF<7:0> <sup>(1)</sup>							
bit 7							bit 0

### Legend:

R = Readable bit	W = Writable bit	U = Unimplemented bit, read as '0'
u = Bit is unchanged	x = Bit is unknown	-n/n = Value at POR and BOR/Value at all other Resets
'1' = Bit is set	'0' = Bit is cleared	HS = Hardware Settable bit

bit 7-0      **IOCCF<7:0>**: Interrupt-On-Change PORTC Flag bits<sup>(1)</sup>  
 1 = An enabled change was detected on the associated pin  
       Set when IOCCPx = 1 and a rising edge was detected on RCx, or when IOCCNx = 1 and a falling edge was detected on RCx  
 0 = No change was detected or the user cleared the detected change

**Note 1:** Bits<7:6> are available on PIC16(L)F1768/9 only.

**TABLE 13-1: SUMMARY OF REGISTERS ASSOCIATED WITH INTERRUPT-ON-CHANGE**

Name	Bit 7	Bit 6	Bit 5	Bit 4	Bit 3	Bit 2	Bit 1	Bit 0	Register on Page
ANSELA	—	—	—	ANSA4	—	ANSA<2:0>			139
ANSELB <sup>(1)</sup>	ANSB<7:4>				—	—	—	—	145
ANSELC	ANSC<7:6> <sup>(1)</sup>		—	—	ANSC<3:0>				150
INTCON	GIE	PEIE	TMR0IE	INTE	IOCIE	TMR0IF	INTF	IOCIF	101
IOCAF	—	—	IOCAF<5:0>						165
IOCAN	—	—	IOCAN<5:0>						164
IOCAP	—	—	IOCAP<5:0>						164
IOCBF <sup>(1)</sup>	IOCBF<7:4>				—	—	—	—	166
IOCBN <sup>(1)</sup>	IOCBN<7:4>				—	—	—	—	166
IOCBP <sup>(1)</sup>	IOCBP<7:4>				—	—	—	—	165
IOCCF	IOCCF<7:6> <sup>(1)</sup>		IOCCF<5:0>						168
IOCCN	IOCCN<7:6> <sup>(1)</sup>		IOCCN<5:0>						167
IOCCP	IOCCP<7:6> <sup>(1)</sup>		IOCCP<5:0>						167
TRISA	—	—	TRISA<5:4>		— <sup>(2)</sup>	TRISA<2:0>			138
TRISB <sup>(1)</sup>	TRISB<7:4>				—	—	—	—	144
TRISC	TRISC<7:6> <sup>(1)</sup>		TRISC<5:0>						149

**Legend:** — = unimplemented location, read as '0'. Shaded cells are not used by Interrupt-On-Change.

**Note 1:** PIC16(L)F1768/9 only.

**2:** Unimplemented, read as '1'.



## 14.0 FIXED VOLTAGE REFERENCE (FVR)

The Fixed Voltage Reference, or FVR, is a stable voltage reference, independent of V<sub>DD</sub>, with 1.024V, 2.048V or 4.096V selectable output levels. The output of the FVR can be configured to supply a reference voltage to the following:

- ADC input channel
- ADC positive reference
- Comparator positive input
- Digital-to-Analog Converter (DAC)

The FVR can be enabled by setting the FVREN bit of the FVRCON register.

### 14.1 Independent Gain Amplifiers

The output of the FVR supplied to the ADC, Comparators and DAC is routed through two independent Programmable Gain Amplifiers (PGAs). Each amplifier can be programmed for a gain of 1x, 2x or 4x, to produce the three possible voltage levels.

The ADFVR<1:0> bits of the FVRCON register are used to enable and configure the gain amplifier settings for the reference supplied to the ADC module. Reference [Section 16.0 “Analog-to-Digital Converter \(ADC\) Module”](#) for additional information.

The CDAFVR<1:0> bits of the FVRCON register are used to enable and configure the gain amplifier settings for the reference supplied to the DAC and comparator module. Reference [Section 17.0 “5-Bit Digital-to-Analog Converter \(DAC\) Module”](#) and [Section 19.0 “Comparator Module”](#) for additional information.

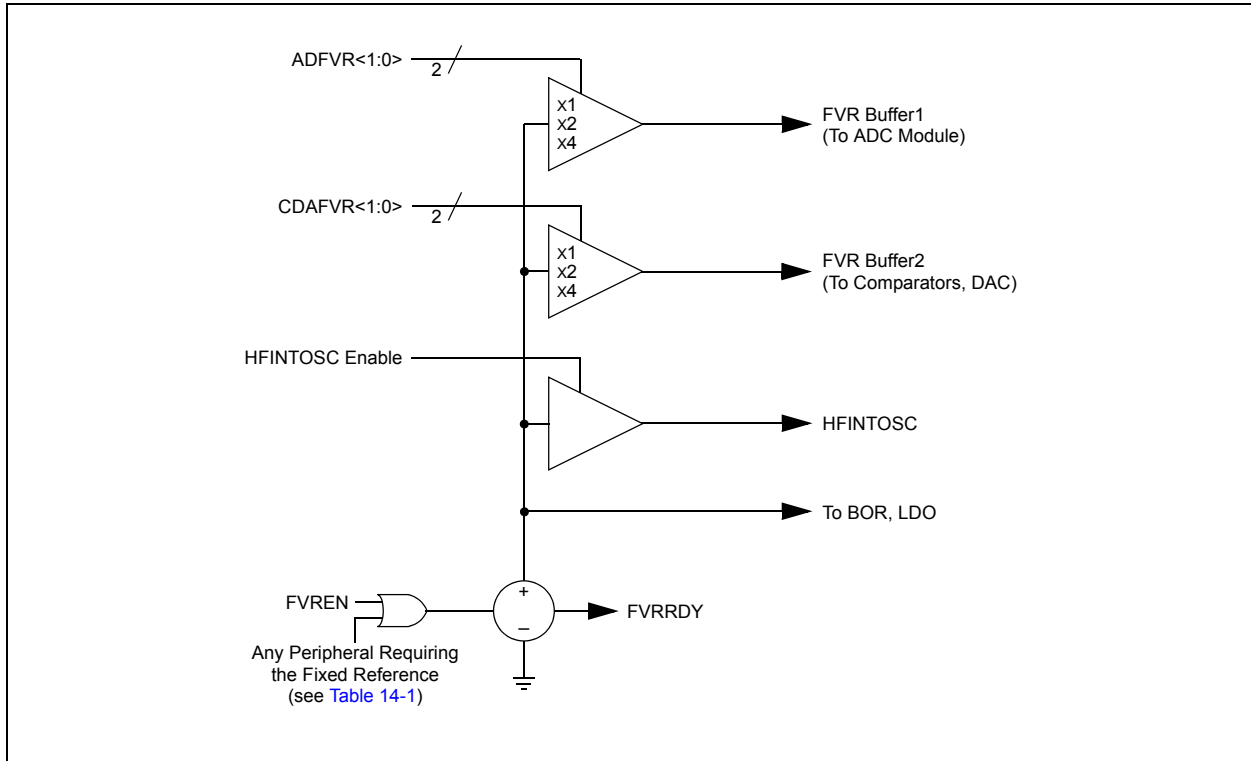
### 14.2 FVR Stabilization Period

When the Fixed Voltage Reference module is enabled, it requires time for the reference and amplifier circuits to stabilize. Once the circuits stabilize and are ready for use, the FVRRDY bit of the FVRCON register will be set. See [Figure 37-76](#) in [Section 37.0 “DC and AC Characteristics Graphs and Charts”](#).

### 14.3 FVR Buffer Stabilization Period

When either FVR Buffer1 or Buffer2 is enabled, then the buffer amplifier circuits require 30 μs to stabilize. This stabilization time is required even when the FVR is already operating and stable.

**FIGURE 14-1: VOLTAGE REFERENCE BLOCK DIAGRAM**



**TABLE 14-1: PERIPHERALS REQUIRING THE FIXED VOLTAGE REFERENCE (FVR)**

Peripheral	Conditions	Description
HFINTOSC	FOSC<2:0> = 100 and IRCF<3:0> ≠ 000x	INTOSC is active and device is not in Sleep
BOR	BOREN<1:0> = 11	BOR is always enabled
	BOREN<1:0> = 10 and BORFS = 1	BOR is disabled in Sleep mode, BOR fast start is enabled
	BOREN<1:0> = 01 and BORFS = 1	BOR under software control, BOR fast start is enabled
LDO	All PIC16F1764/5/8/9 devices when VREGPM = 1 and not in Sleep	The device runs off of the ULP regulator when in Sleep mode

## 14.4 Register Definitions: FVR Control

**REGISTER 14-1: FVRCON: FIXED VOLTAGE REFERENCE CONTROL REGISTER**

R/W-0/0	R-q/q	R/W-0/0	R/W-0/0	R/W-0/0	R/W-0/0	R/W-0/0	R/W-0/0
FVREN	FVRRDY <sup>(1)</sup>	TSEN <sup>(3)</sup>	TSRNG <sup>(3)</sup>	CDAFVR<1:0>		ADFVR<1:0>	
bit 7							bit 0

**Legend:**

R = Readable bit	W = Writable bit	U = Unimplemented bit, read as '0'
u = Bit is unchanged	x = Bit is unknown	-n/n = Value at POR and BOR/Value at all other Resets
'1' = Bit is set	'0' = Bit is cleared	q = Value depends on condition

bit 7	<b>FVREN:</b> Fixed Voltage Reference Enable bit 1 = Fixed Voltage Reference is enabled 0 = Fixed Voltage Reference is disabled
bit 6	<b>FVRRDY:</b> Fixed Voltage Reference Ready Flag bit <sup>(1)</sup> 1 = Fixed Voltage Reference output is ready for use 0 = Fixed Voltage Reference output is not ready or not enabled
bit 5	<b>TSEN:</b> Temperature Indicator Enable bit <sup>(3)</sup> 1 = Temperature indicator is enabled 0 = Temperature indicator is disabled
bit 4	<b>TSRNG:</b> Temperature Indicator Range Selection bit <sup>(3)</sup> 1 = $V_{OUT} = V_{DD} - 4 V_T$ (High Range) 0 = $V_{OUT} = V_{DD} - 2 V_T$ (Low Range)
bit 3-2	<b>CDAFVR&lt;1:0&gt;:</b> Comparator/DAC FVR Buffer Gain Selection bits 11 = Comparator/DAC FVR buffer gain is 4x with output, $V_{CDAFVR} = 4x V_{FVR}$ <sup>(2)</sup> 10 = Comparator/DAC FVR buffer gain is 2x with output, $V_{CDAFVR} = 2x V_{FVR}$ <sup>(2)</sup> 01 = Comparator/DAC FVR buffer gain is 1x with output, $V_{CDAFVR} = 1x V_{FVR}$ 00 = Comparator/DAC FVR buffer is off
bit 1-0	<b>ADFVR&lt;1:0&gt;:</b> ADC FVR Buffer Gain Selection bits 11 = ADC FVR buffer gain is 4x with output, $V_{ADFVR} = 4x V_{FVR}$ <sup>(2)</sup> 10 = ADC FVR buffer gain is 2x with output, $V_{ADFVR} = 2x V_{FVR}$ <sup>(2)</sup> 01 = ADC FVR buffer gain is 1x with output, $V_{ADFVR} = 1x V_{FVR}$ 00 = ADC FVR buffer is off

- Note 1:** FVRRDY is always '1' on PIC16F1764/5/8/9 only.  
**2:** Fixed Voltage Reference output cannot exceed VDD.  
**3:** See [Section 15.0 "Temperature Indicator Module"](#) for additional information.

**TABLE 14-2: SUMMARY OF REGISTERS ASSOCIATED WITH FIXED VOLTAGE REFERENCE**

Name	Bit 7	Bit 6	Bit 5	Bit 4	Bit 3	Bit 2	Bit 1	Bit 0	Register on Page
FVRCON	FVREN	FVRRDY	TSEN	TSRNG	CDAFVR<1:0>		ADFVR<1:0>		<a href="#">171</a>

## 15.0 TEMPERATURE INDICATOR MODULE

This family of devices is equipped with a temperature circuit designed to measure the operating temperature of the silicon die. The circuit's range of operating temperature falls between  $-40^{\circ}\text{C}$  and  $+85^{\circ}\text{C}$ . The output is a voltage that is proportional to the device temperature. The output of the temperature indicator is internally connected to the device ADC.

The circuit may be used as a temperature threshold detector or a more accurate temperature indicator, depending on the level of calibration performed. A one-point calibration allows the circuit to indicate a temperature closely surrounding that point. A two-point calibration allows the circuit to sense the entire range of temperature more accurately. Reference Application Note AN1333, "Use and Calibration of the Internal Temperature Indicator" (DS00001333) for more details regarding the calibration process.

### 15.1 Circuit Operation

Figure 15-1 shows a simplified block diagram of the temperature circuit. The proportional voltage output is achieved by measuring the forward voltage drop across multiple silicon junctions.

Equation 15-1 describes the output characteristics of the temperature indicator.

#### EQUATION 15-1: $V_{OUT}$ RANGES

$$\begin{aligned} \text{High Range: } V_{OUT} &= V_{DD} - 4V_T \\ \text{Low Range: } V_{OUT} &= V_{DD} - 2V_T \end{aligned}$$

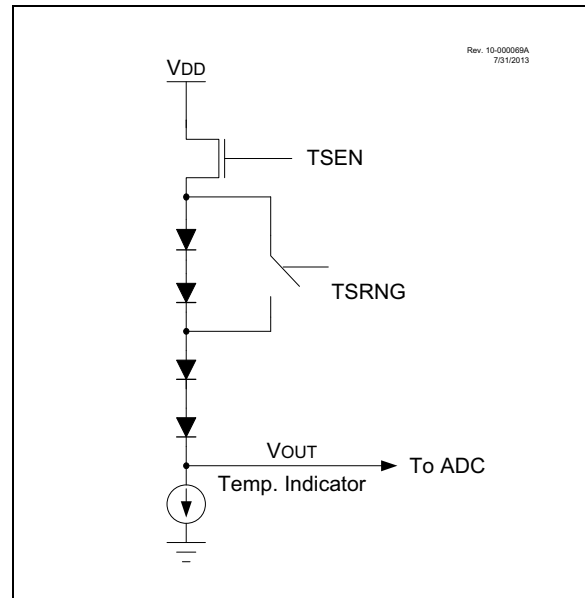
The temperature sense circuit is integrated with the Fixed Voltage Reference (FVR) module. See Section 14.0 "Fixed Voltage Reference (FVR)" for more information.

The circuit is enabled by setting the TSEN bit of the FVRCON register. When disabled, the circuit draws no current.

The circuit operates in either high or low range. The high range, selected by setting the TSRNG bit of the FVRCON register, provides a wider output voltage. This provides more resolution over the temperature range, but may be less consistent from part to part. This range requires a higher bias voltage to operate and thus, a higher  $V_{DD}$  is needed.

The low range is selected by clearing the TSRNG bit of the FVRCON register. The low range generates a lower voltage drop and thus, a lower bias voltage is needed to operate the circuit. The low range is provided for low-voltage operation.

FIGURE 15-1: TEMPERATURE CIRCUIT DIAGRAM



### 15.2 Minimum Operating $V_{DD}$

When the temperature circuit is operated in low range, the device may be operated at any operating voltage that is within specifications.

When the temperature circuit is operated in high range, the device operating voltage,  $V_{DD}$ , must be high enough to ensure that the temperature circuit is correctly biased.

Table 15-1 shows the recommended minimum  $V_{DD}$  vs. range setting.

TABLE 15-1: RECOMMENDED  $V_{DD}$  VS. RANGE

Min. $V_{DD}$ , TSRNG = 1	Min. $V_{DD}$ , TSRNG = 0
3.6V	1.8V

## 15.3 Temperature Output

The output of the circuit is measured using the internal Analog-to-Digital Converter. A channel is reserved for the temperature circuit output. Refer to [Section 16.0 “Analog-to-Digital Converter \(ADC\) Module”](#) for detailed information.

## 15.4 ADC Acquisition Time

To ensure accurate temperature measurements, the user must wait at least 200  $\mu\text{s}$  after the ADC input multiplexer is connected to the temperature indicator output before the conversion is performed. In addition, the user must wait 200  $\mu\text{s}$  between sequential conversions of the temperature indicator output.

**TABLE 15-2: SUMMARY OF REGISTERS ASSOCIATED WITH THE TEMPERATURE INDICATOR**

Name	Bit 7	Bit 6	Bit 5	Bit 4	Bit 3	Bit 2	Bit 1	Bit 0	Register on Page
FVRCON	FVREN	FVRRDY	TSEN	TSRNG	CDFVR<1:0>		ADFVR<1:0>		<a href="#">171</a>

**Legend:** Shaded cells are unused by the temperature indicator module.

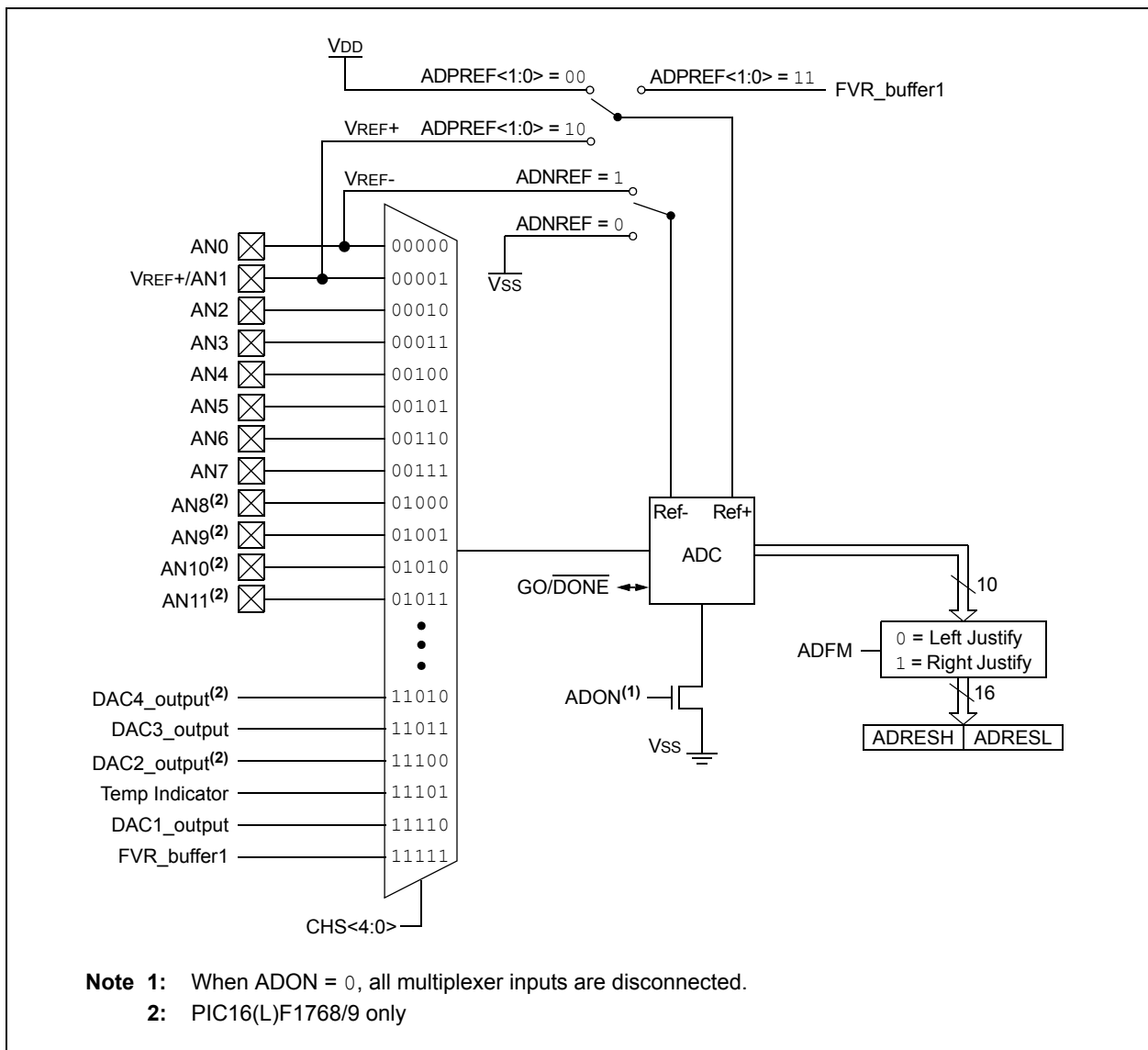
## 16.0 ANALOG-TO-DIGITAL CONVERTER (ADC) MODULE

The Analog-to-Digital Converter (ADC) allows conversion of an analog input signal to a 10-bit binary representation of that signal. This device uses analog inputs, which are multiplexed into a single Sample-and-Hold (S&H) circuit. The output of the Sample-and-Hold is connected to the input of the converter. The converter generates a 10-bit binary result via successive approximation and stores the conversion result into the ADC Result registers (ADRESH:ADRESL register pair). Figure 16-1 shows the block diagram of the ADC.

The ADC voltage reference is software-selectable to be either internally generated or externally supplied.

The ADC can generate an interrupt upon completion of a conversion. This interrupt can be used to wake-up the device from Sleep.

**FIGURE 16-1: ADC BLOCK DIAGRAM**



## 16.1 ADC Configuration

When configuring and using the ADC the following functions must be considered:

- Port configuration
- Channel selection
- ADC voltage reference selection
- ADC conversion clock source
- Interrupt control
- Result formatting

### 16.1.1 PORT CONFIGURATION

The ADC can be used to convert both analog and digital signals. When converting analog signals, the I/O pin should be configured for analog by setting the associated TRISx and ANSELx bits. Refer to [Section 11.0 “I/O Ports”](#) for more information.

**Note:** Analog voltages on any pin that is defined as a digital input may cause the input buffer to conduct excess current.

### 16.1.2 CHANNEL SELECTION

There are up to 18 channel selections available:

- AN<7:0> pins
- AN<11:8> pins (PIC16(L)F1768/9 only)
- Temperature indicator
- DAC1\_output and DAC3\_output
- DAC2\_output and DAC4\_output (PIC16(L)F1768/9 only)
- FVR\_buffer1

The CHS<4:0> bits of the ADCON0 register ([Register 16-1](#)) determine which channel is connected to the Sample-and-Hold circuit.

When changing channels, a delay is required before starting the next conversion. Refer to [Section 16.2 “ADC Operation”](#) for more information.

**Note:** It is recommended that when switching from an ADC channel of a higher voltage to a channel of a lower voltage, that the user selects the Vss channel before connecting to the channel with the lower voltage. If the ADC does not have a dedicated Vss input channel, the Vss selection (DAC1R<4:0> = b'00000') through the DAC output channel can be used. If the DAC is in use, a free input channel can be connected to Vss, and can be used in place of the DAC.

### 16.1.3 ADC POSITIVE VOLTAGE REFERENCE

The ADPREF<1:0> bits of the ADCON1 register provide control of the positive voltage reference. The positive voltage reference can be:

- VREF+ pin

- VDD
- FVR 2.048V
- FVR 4.096V (not available on LF devices)
- Vss

See [Section 16.0 “Analog-to-Digital Converter \(ADC\) Module”](#) for more details on the Fixed Voltage Reference.

### 16.1.4 ADC NEGATIVE VOLTAGE REFERENCE

The ADNREF bit of the ADCON1 register provides control of the negative voltage reference. The negative voltage reference can be:

- VREF- pin
- Vss

### 16.1.5 CONVERSION CLOCK

The source of the conversion clock is software-selectable via the ADCS<2:0> bits of the ADCON1 register. There are seven possible clock options:

- Fosc/2
- Fosc/4
- Fosc/8
- Fosc/16
- Fosc/32
- Fosc/64
- FRC (internal RC oscillator)

The time to complete one bit conversion is defined as TAD. One full 10-bit conversion requires 11.5 TAD periods, as shown in [Figure 16-2](#).

For correct conversion, the appropriate TAD specification must be met. Refer to [Table 36-16: ADC Conversion Requirements](#) for more information. [Table 16-1](#) gives examples of appropriate ADC clock selections.

**Note:** Unless using the FRC, any changes in the system clock frequency will change the ADC clock frequency, which may adversely affect the ADC result.

**TABLE 16-1: ADC CLOCK PERIOD (TAD) vs. DEVICE OPERATING FREQUENCIES**

ADC Clock Period (TAD)		Device Frequency (Fosc)					
ADC Clock Source	ADCS<2:0>	32 MHz	20 MHz	16 MHz	8 MHz	4 MHz	1 MHz
Fosc/2	000	62.5ns <sup>(2)</sup>	100 ns <sup>(2)</sup>	125 ns <sup>(2)</sup>	250 ns <sup>(2)</sup>	500 ns <sup>(2)</sup>	2.0 μs
Fosc/4	100	125 ns <sup>(2)</sup>	200 ns <sup>(2)</sup>	250 ns <sup>(2)</sup>	500 ns <sup>(2)</sup>	1.0 μs	4.0 μs
Fosc/8	001	0.5 μs <sup>(2)</sup>	400 ns <sup>(2)</sup>	0.5 μs <sup>(2)</sup>	1.0 μs	2.0 μs	8.0 μs <sup>(3)</sup>
Fosc/16	101	800 ns	800 ns	1.0 μs	2.0 μs	4.0 μs	16.0 μs <sup>(2)</sup>
Fosc/32	010	1.0 μs	1.6 μs	2.0 μs	4.0 μs	8.0 μs <sup>(3)</sup>	32.0 μs <sup>(2)</sup>
Fosc/64	110	2.0 μs	3.2 μs	4.0 μs	8.0 μs <sup>(3)</sup>	16.0 μs <sup>(2)</sup>	64.0 μs <sup>(2)</sup>
FRC	x11	1.0-6.0 μs <sup>(1,4)</sup>	1.0-6.0 μs <sup>(1,4)</sup>	1.0-6.0 μs <sup>(1,4)</sup>	1.0-6.0 μs <sup>(1,4)</sup>	1.0-6.0 μs <sup>(1,4)</sup>	1.0-6.0 μs <sup>(1,4)</sup>

**Legend:** Shaded cells are outside of the recommended range.

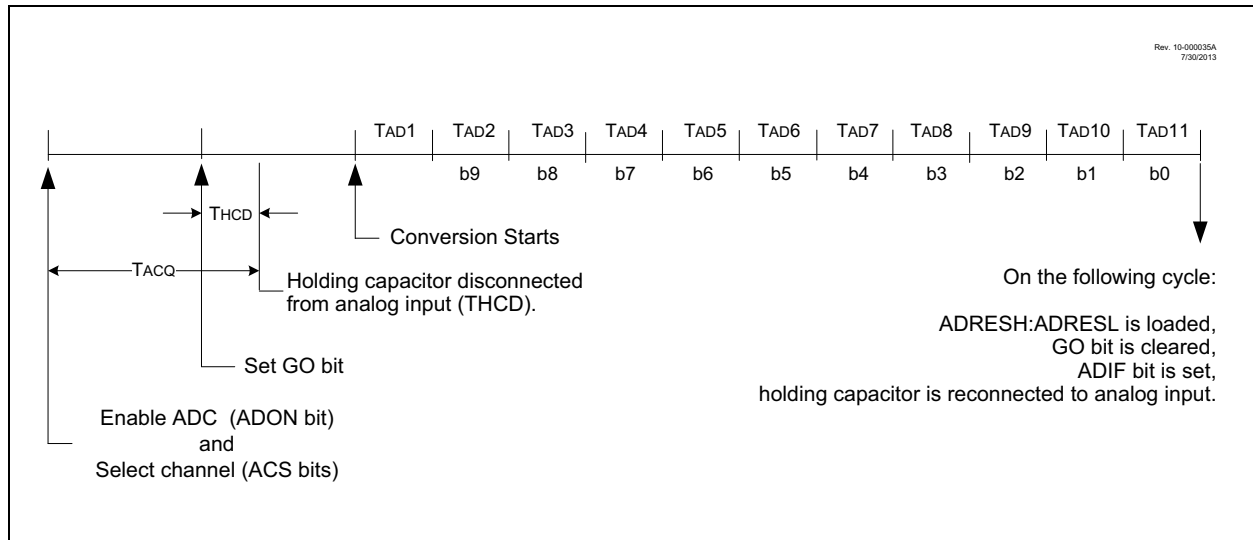
**Note 1:** See the TAD parameter for FRC source typical TAD value.

**2:** These values violate the required TAD time.

**3:** Outside the recommended TAD time.

**4:** The ADC clock period (TAD) and total ADC conversion time can be minimized when the ADC clock is derived from the system clock, Fosc. However, the FRC oscillator source must be used when conversions are to be performed with the device in Sleep mode.

**FIGURE 16-2: ANALOG-TO-DIGITAL CONVERSION TAD CYCLES**





## 16.1.6 INTERRUPTS

The ADC module allows for the ability to generate an interrupt upon completion of an Analog-to-Digital conversion. The ADC Interrupt Flag is the ADIF bit in the PIR1 register. The ADC Interrupt Enable bit is the ADIE bit in the PIE1 register. The ADIF bit must be cleared in software.

**Note 1:** The ADIF bit is set at the completion of every conversion, regardless of whether or not the ADC interrupt is enabled.

**2:** The ADC operates during Sleep only when the FRC oscillator is selected.

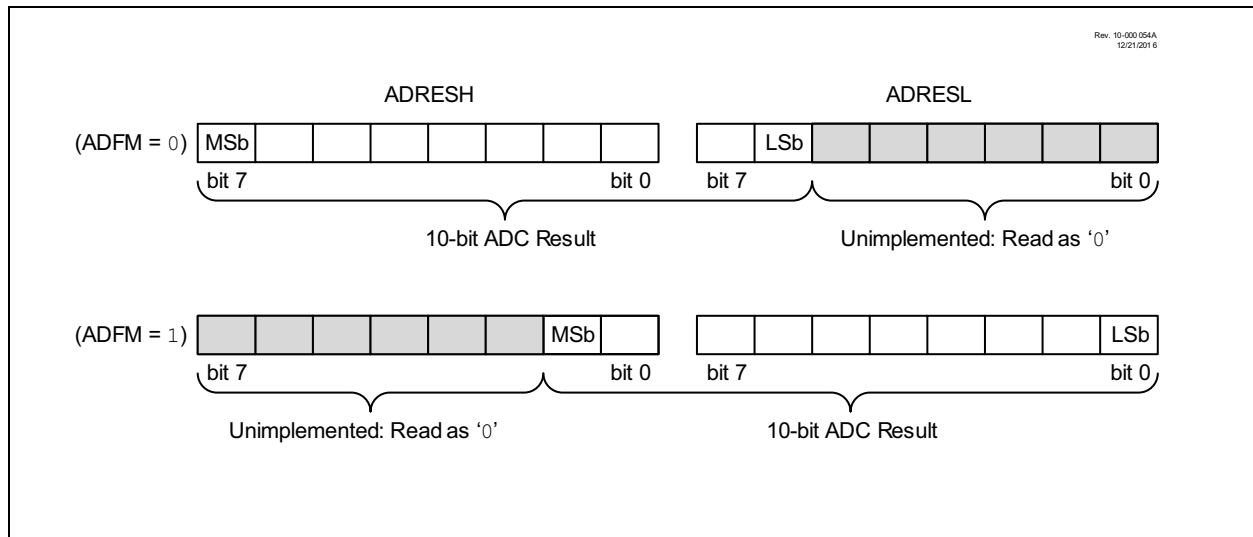
This interrupt can be generated while the device is operating or while in Sleep. If the device is in Sleep, the interrupt will wake-up the device. Upon waking from Sleep, the next instruction following the SLEEP instruction is always executed. If the user is attempting to wake-up from Sleep and resume in-line code execution, the ADIE bit of the PIE1 register and the PEIE bit of the INTCON register must both be set, and the GIE bit of the INTCON register must be cleared. If all three of these bits are set, the execution will switch to the Interrupt Service Routine.

## 16.1.7 RESULT FORMATTING

The 10-bit ADC conversion result can be supplied in two formats, left justified or right justified. The ADFM bit of the ADCON1 register controls the output format.

Figure 16-3 shows the two output formats.

**FIGURE 16-3: 10-BIT ADC CONVERSION RESULT FORMAT**



## 16.2 ADC Operation

### 16.2.1 STARTING A CONVERSION

To enable the ADC module, the ADON bit of the ADCON0 register must be set to a '1'. Setting the GO/DONE bit of the ADCON0 register to a '1' will start the Analog-to-Digital conversion.

**Note:** The GO/DONE bit should not be set in the same instruction that turns on the ADC. Refer to [Section 16.2.6 “ADC Conversion Procedure”](#).

### 16.2.2 COMPLETION OF A CONVERSION

When the conversion is complete, the ADC module will:

- Clear the GO/DONE bit
- Set the ADIF interrupt flag bit
- Update the ADRESH and ADRESL registers with the new conversion result

### 16.2.3 TERMINATING A CONVERSION

If a conversion must be terminated before completion, the GO/DONE bit can be cleared in software. The ADRESH and ADRESL registers will be updated with the partially complete Analog-to-Digital conversion sample. Incomplete bits will match the last bit converted.

**Note:** A device Reset forces all registers to their Reset state. Thus, the ADC module is turned off and any pending conversion is terminated.

### 16.2.4 ADC OPERATION DURING SLEEP

The ADC module can operate during Sleep. This requires the ADC clock source to be set to the FRC option. When the FRC oscillator source is selected, the ADC waits one additional instruction before starting the conversion. This allows the SLEEP instruction to be executed, which can reduce system noise during the conversion. If the ADC interrupt is enabled, the device will wake-up from Sleep when the conversion completes. If the ADC interrupt is disabled, the ADC module is turned off after the conversion completes, although the ADON bit remains set.

When the ADC clock source is something other than FRC, a SLEEP instruction causes the present conversion to be aborted and the ADC module is turned off, although the ADON bit remains set.

### 16.2.5 AUTO-CONVERSION TRIGGER

The auto-conversion trigger allows periodic ADC measurements without software intervention. When a rising edge of the selected source occurs, the GO/DONE bit is set by hardware.

The auto-conversion trigger source is selected with the TRIGSEL<4:0> bits of the ADCON2 register.

Using the auto-conversion trigger does not assure proper ADC timing. It is the user's responsibility to ensure that the ADC timing requirements are met.

See [Table 16-2](#) for auto-conversion sources.

**TABLE 16-2: AUTO-CONVERSION SOURCES**

Source Peripheral	Signal Name
CCP1	CCP1_trigger
CCP2 <sup>(1)</sup>	CCP2_trigger
Timer0	T0_overflow
Timer1	T1_overflow
Timer3	T3_overflow
Timer5	T5_overflow
Timer2	T2_postscaled
Timer4	T4_postscaled
Timer6	T6_postscaled
Comparator C1	sync_C1OUT
Comparator C2	sync_C2OUT
Comparator C3 <sup>(1)</sup>	sync_C3OUT
Comparator C4 <sup>(1)</sup>	sync_C4OUT
CLC1	LC1_out
CLC2	LC2_out
CLC3	LC3_out
PWM3	PWM3OUT
PWM4 <sup>(1)</sup>	PWM4OUT
PWM5	PR/PH/OF/DC5_match
PWM6 <sup>(1)</sup>	PR/PH/OF/DC6_match

**Note 1:** PIC16(L)F1768/9 only

## 16.2.6 ADC CONVERSION PROCEDURE

This is an example procedure for using the ADC to perform an Analog-to-Digital conversion:

1. Configure the PORT:
  - Disable the pin output driver (refer to the TRISx register)
  - Configure pin as an analog (refer to the ANSELx register)
  - Disable weak pull-ups either globally (Refer to the OPTION\_REG register) or individually (Refer to the appropriate WPUx register)
2. Configure the ADC module:
  - Select ADC conversion clock
  - Configure voltage reference
  - Select ADC input channel
  - Turn on ADC module
3. Configure ADC interrupt (optional):
  - Clear ADC interrupt flag
  - Enable ADC interrupt
  - Enable peripheral interrupt
  - Enable global interrupt<sup>(1)</sup>
4. Wait the required acquisition time.<sup>(2)</sup>
5. Start conversion by setting the GO/DONE bit.
6. Wait for ADC conversion to complete by one of the following:
  - Polling the GO/DONE bit
  - Waiting for the ADC interrupt (interrupts enabled)
7. Read ADC result.
8. Clear the ADC interrupt flag (required if interrupt is enabled).

**Note 1:** The global interrupt can be disabled if the user is attempting to wake-up from Sleep and resume in-line code execution.

**2:** Refer to [Section 16.4 “ADC Acquisition Requirements”](#).

## EXAMPLE 16-1: ADC CONVERSION

```

;This code block configures the ADC
;for polling, Vdd and Vss references, FRC
;oscillator and AN0 input.
;
;Conversion start & polling for completion
; are included.
;
BANKSEL    ADCON1    ;
MOVLW     B'11110000' ;Right justify, FRC
;oscillator
MOVWF     ADCON1    ;Vdd and Vss Vref
BANKSEL    TRISA    ;
BSF       TRISA,0   ;Set RA0 to input
BANKSEL    ANSEL    ;
BSF       ANSEL,0   ;Set RA0 to analog
BANKSEL    WPUA    ;
BCF       WPUA,0   ;Disable weak
;pull-up on RA0

BANKSEL    ADCON0    ;
MOVLW     B'00000001' ;Select channel AN0
MOVWF     ADCON0    ;Turn ADC On
CALL      SampleTime ;Acquisiton delay
BSF       ADCON0,ADGO ;Start conversion
BTFSC    ADCON0,ADGO ;Is conversion done?
GOTO     $-1        ;No, test again
BANKSEL    ADRESH    ;
MOVWF     ADRESH,W  ;Read upper 2 bits
MOVWF     RESULTHI  ;store in GPR space
BANKSEL    ADRESL    ;
MOVWF     ADRESL,W  ;Read lower 8 bits
MOVWF     RESULTLO  ;Store in GPR space
    
```

## 16.3 Register Definitions: ADC Control

### REGISTER 16-1: ADCON0: ADC CONTROL REGISTER 0

U-0	R/W-0/0	R/W-0/0	R/W-0/0	R/W-0/0	R/W-0/0	R/W-0/0	R/W-0/0
—	CHS<4:0>					GO/DONE	ADON
bit 7							bit 0

#### Legend:

R = Readable bit	W = Writable bit	
u = Bit is unchanged	x = Bit is unknown	U = Unimplemented bit, read as '0'
'1' = Bit is set	'0' = Bit is cleared	-n/n = Value at POR and BOR/Value at all other Resets

bit 7 **Unimplemented:** Read as '0'

bit 6-2 **CHS<4:0>:** Analog Channel Select bits

11111 = FVR (Fixed Voltage Reference) Buffer1 Output<sup>(2)</sup>

11110 = DAC1\_output<sup>(1)</sup>

11101 = Temperature indicator<sup>(3)</sup>

11100 = DAC2\_output<sup>(1,5)</sup>

11011 = DAC3\_output<sup>(4)</sup>

11010 = DAC4\_output<sup>(4,5)</sup>

11001 = Reserved; no channel connected

•  
•  
•

01111 = Switched AN7<sup>(5,6)</sup>

01110 = Switched AN6<sup>(6)</sup>

01101 = Reserved; no channel connected.

01100 = Reserved; no channel connected.

01011 = AN11<sup>(5)</sup>

01010 = AN10<sup>(5)</sup>

01001 = AN9<sup>(5)</sup>

01000 = AN8<sup>(5)</sup>

00111 = AN7

00110 = AN6

00101 = AN5

00100 = AN4

00011 = AN3

00010 = AN2

00001 = AN1

00000 = AN0

bit 1 **GO/DONE:** ADC Conversion Status bit

1 = ADC conversion cycle in progress; setting this bit starts an ADC conversion cycle

This bit is automatically cleared by hardware when the ADC conversion has completed.

0 = ADC conversion completed/not in progress

bit 0 **ADON:** ADC Enable bit

1 = ADC is enabled

0 = ADC is disabled and consumes no operating current

**Note 1:** See [Section 17.0 “5-Bit Digital-to-Analog Converter \(DAC\) Module”](#) for more information.

**2:** See [Section 14.0 “Fixed Voltage Reference \(FVR\)”](#) for more information.

**3:** See [Section 15.0 “Temperature Indicator Module”](#) for more information.

**4:** See [Section 18.0 “10-Bit Digital-to-Analog Converter \(DAC\) Module”](#) for more information.

**5:** PIC16(L)F1768/9 only.

**6:** Input source is switched off when op amp override is forced tri-state. See [Section 29.3 “Override Control”](#).

# PIC16(L)F1764/5/8/9

**REGISTER 16-2: ADCON1: ADC CONTROL REGISTER 1**

R/W-0/0	R/W-0/0	R/W-0/0	R/W-0/0	U-0	R/W-0/0	R/W-0/0	R/W-0/0
ADFM	ADCS<2:0>		—	ADNREF	ADPREF<1:0>		
bit 7							bit 0

**Legend:**

R = Readable bit	W = Writable bit	
u = Bit is unchanged	x = Bit is unknown	U = Unimplemented bit, read as '0'
'1' = Bit is set	'0' = Bit is cleared	-n/n = Value at POR and BOR/Value at all other Resets

- bit 7      **ADFM:** ADC Result Format Select bit  
 1 = Right justified; six Most Significant bits of ADRESH are set to '0' when the conversion result is loaded  
 0 = Left justified; six Least Significant bits of ADRESL are set to '0' when the conversion result is loaded
- bit 6-4    **ADCS<2:0>:** ADC Conversion Clock Select bits  
 111 = FRC (clock supplied from an internal RC oscillator)  
 110 = Fosc/64  
 101 = Fosc/16  
 100 = Fosc/4  
 011 = FRC (clock supplied from an internal RC oscillator)  
 010 = Fosc/32  
 001 = Fosc/8  
 000 = Fosc/2
- bit 3      **Unimplemented:** Read as '0'
- bit 2      **ADNREF:** ADC Negative Voltage Reference Configuration bit  
 1 =VREF- is connected to external VREF- pin  
 0 =VREF- is connected to VSS
- bit 1-0    **ADPREF<1:0>:** ADC Positive Voltage Reference Configuration bits  
 11 = VREF+ is connected to the internal Fixed Voltage Reference (FVR) module<sup>(1)</sup>  
 10 = VREF+ is connected to the external VREF+ pin<sup>(1)</sup>  
 01 = Reserved  
 00 = VREF+ is connected to VDD

**Note 1:** When selecting the VREF+ pin as the source of the positive reference, be aware that a minimum voltage specification exists. See [Table 36-16](#) for details.

## REGISTER 16-3: ADCON2: ADC CONTROL REGISTER 2

R/W-0/0	R/W-0/0	R/W-0/0	R/W-0/0	R/W-0/0	U-0	U-0	U-0
TRIGSEL<4:0> <sup>(1)</sup>					—	—	—
bit 7					bit 0		

### Legend:

R = Readable bit	W = Writable bit	U = Unimplemented bit, read as '0'
u = Bit is unchanged	x = Bit is unknown	-n/n = Value at POR and BOR/Value at all other Resets
'1' = Bit is set	'0' = Bit is cleared	

bit 7-3      **TRIGSEL<4:0>**: Auto-Conversion Trigger Selection bits<sup>(1)</sup>

11111 = Reserved  
 •  
 •  
 •  
 11011 = Reserved  
 11010 = PWM6 – OF6\_match<sup>(2)</sup>  
 11001 = PWM6 – PH6\_match<sup>(2)</sup>  
 11000 = PWM6 – PR6\_match<sup>(2)</sup>  
 10111 = PWM6 – DC6\_match<sup>(2)</sup>  
 10110 = PWM5 – OF5\_match  
 10101 = PWM5 – PH5\_match  
 10100 = PWM5 – PR5\_match  
 10011 = PWM5 – DC5\_match  
 10010 = PWM4 – PWM4OUT<sup>(2)</sup>  
 10001 = PWM3 – PWM3OUT  
 10000 = CCP2 – CCP2\_trigger<sup>(2)</sup>  
 01111 = CCP1 – CCP1\_trigger  
 01110 = CLC3 – LC3\_out  
 01101 = CLC2 – LC2\_out  
 01100 = CLC1 – LC1\_out  
 01011 = Comparator C4 – sync\_C4OUT<sup>(2)</sup>  
 01010 = Comparator C3 – sync\_C3OUT<sup>(2)</sup>  
 01001 = Comparator C2 – sync\_C2OUT  
 01000 = Comparator C1 – sync\_C1OUT  
 00111 = Timer6 – T6\_postscaled  
 00110 = Timer5 – T5\_overflow  
 00101 = Timer4 – T4\_postscaled  
 00100 = Timer3 – T3\_overflow  
 00011 = Timer2 – T2\_postscaled  
 00010 = Timer1 – T1\_overflow  
 00001 = Timer0 – T0\_overflow  
 00000 = No auto-conversion trigger selected

bit 3-0      **Unimplemented:** Read as '0'

**Note 1:** This is a rising edge-sensitive input for all sources.

**2:** PIC16(L)F1768/9 only; reserved otherwise.

## REGISTER 16-4: ADRESH: ADC RESULT REGISTER HIGH (ADFM = 0)

R/W-x/u	R/W-x/u	R/W-x/u	R/W-x/u	R/W-x/u	R/W-x/u	R/W-x/u	R/W-x/u
ADRES<9:2>							
bit 7							bit 0

### Legend:

R = Readable bit	W = Writable bit	
u = Bit is unchanged	x = Bit is unknown	U = Unimplemented bit, read as '0'
'1' = Bit is set	'0' = Bit is cleared	-n/n = Value at POR and BOR/Value at all other Resets

bit 7-0      **ADRES<9:2>**: ADC Result Register bits  
Upper eight bits of 10-bit conversion result.

## REGISTER 16-5: ADRESL: ADC RESULT REGISTER LOW (ADFM = 0)

R/W-x/u	R/W-x/u	r-x/u	r-x/u	r-x/u	r-x/u	r-x/u	r-x/u
ADRES<1:0>		—	—	—	—	—	—
bit 7							bit 0

### Legend:

R = Readable bit	W = Writable bit	r = Reserved bit
u = Bit is unchanged	x = Bit is unknown	U = Unimplemented bit, read as '0'
'1' = Bit is set	'0' = Bit is cleared	-n/n = Value at POR and BOR/Value at all other Resets

bit 7-6      **ADRES<1:0>**: ADC Result Register bits  
Lower two bits of 10-bit conversion result.

bit 5-0      **Reserved**: Do not use.

## REGISTER 16-6: ADRESH: ADC RESULT REGISTER HIGH (ADFM = 1)

r-x/u	r-x/u	r-x/u	r-x/u	r-x/u	r-x/u	R/W-x/u	R/W-x/u
—	—	—	—	—	—	ADRES<9:8>	
bit 7						bit 0	

### Legend:

R = Readable bit	W = Writable bit	r = Reserved bit
u = Bit is unchanged	x = Bit is unknown	U = Unimplemented bit, read as '0'
'1' = Bit is set	'0' = Bit is cleared	-n/n = Value at POR and BOR/Value at all other Resets

bit 7-2      **Reserved:** Do not use.  
bit 1-0      **ADRES<9:8>:** ADC Result Register bits  
Upper two bits of 10-bit conversion result.

## REGISTER 16-7: ADRESL: ADC RESULT REGISTER LOW (ADFM = 1)

R/W-x/u	R/W-x/u	R/W-x/u	R/W-x/u	R/W-x/u	R/W-x/u	R/W-x/u	R/W-x/u
ADRES<7:0>							
bit 7						bit 0	

### Legend:

R = Readable bit	W = Writable bit	
u = Bit is unchanged	x = Bit is unknown	U = Unimplemented bit, read as '0'
'1' = Bit is set	'0' = Bit is cleared	-n/n = Value at POR and BOR/Value at all other Resets

bit 7-0      **ADRES<7:0>:** ADC Result Register bits  
Lower eight bits of 10-bit conversion result.



## 16.4 ADC Acquisition Requirements

For the ADC to meet its specified accuracy, the Charge Holding Capacitor (CHOLD) must be allowed to fully charge to the input channel voltage level. The analog input model is shown in Figure 16-4. The Source Impedance (RS) and the internal Sampling Switch (RSS) impedance directly affect the time required to charge the capacitor, CHOLD. The Sampling Switch (RSS) impedance varies over the device voltage (VDD), refer to Figure 16-4. **The maximum recommended impedance for analog sources is 10 kΩ.** As the

source impedance is decreased, the acquisition time may be decreased. After the analog input channel is selected (or changed), an ADC acquisition must be done before the conversion can be started. To calculate the minimum acquisition time, Equation 16-1 may be used. This equation assumes that 1/2 LSB error is used (1,024 steps for the ADC). The 1/2 LSB error is the maximum error allowed for the ADC to meet its specified resolution.

### EQUATION 16-1: ACQUISITION TIME EXAMPLE

*Assumptions: Temperature = 50°C and external impedance of 10kΩ 5.0V VDD*

$$\begin{aligned} T_{ACQ} &= \text{Amplifier Settling Time} + \text{Hold Capacitor Charging Time} + \text{Temperature Coefficient} \\ &= T_{AMP} + T_C + T_{COFF} \\ &= 2\mu s + T_C + [(Temperature - 25^\circ C)(0.05\mu s/^\circ C)] \end{aligned}$$

*The value for  $T_C$  can be approximated with the following equations:*

$$V_{APPLIED} \left( 1 - \frac{I}{(2^{n+1}) - I} \right) = V_{CHOLD} \quad ;[1] \text{ } V_{CHOLD} \text{ charged to within } 1/2 \text{ lsb}$$

$$V_{APPLIED} \left( 1 - e^{\frac{-T_C}{RC}} \right) = V_{CHOLD} \quad ;[2] \text{ } V_{CHOLD} \text{ charge response to } V_{APPLIED}$$

$$V_{APPLIED} \left( 1 - e^{\frac{-T_C}{RC}} \right) = V_{APPLIED} \left( 1 - \frac{I}{(2^{n+1}) - I} \right) \quad ;\text{combining [1] and [2]}$$

*Note: Where  $n$  = number of bits of the ADC.*

*Solving for  $T_C$ :*

$$\begin{aligned} T_C &= -CHOLD(RIC + RSS + RS) \ln(1/2047) \\ &= -10pF(1k\Omega + 7k\Omega + 10k\Omega) \ln(0.0004885) \\ &= 1.37\mu s \end{aligned}$$

*Therefore:*

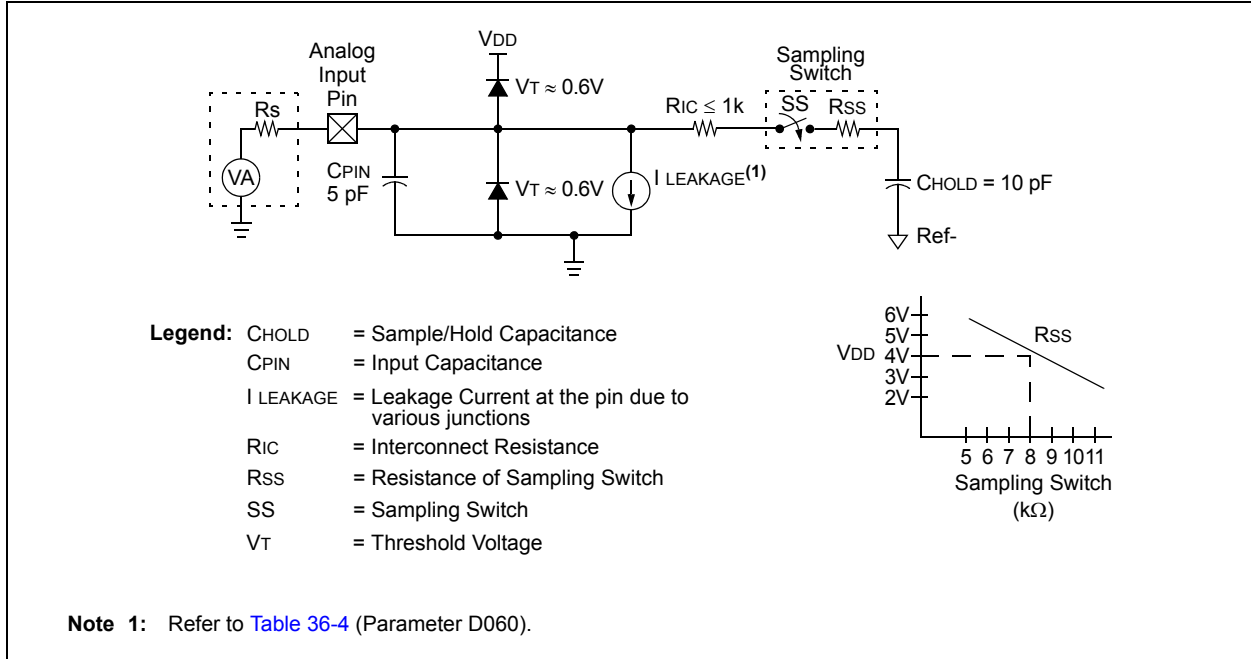
$$\begin{aligned} T_{ACQ} &= 2\mu s + 892ns + [(50^\circ C - 25^\circ C)(0.05\mu s/^\circ C)] \\ &= 4.62\mu s \end{aligned}$$

**Note 1:** The Reference Voltage (VREF) has no effect on the equation, since it cancels itself out.

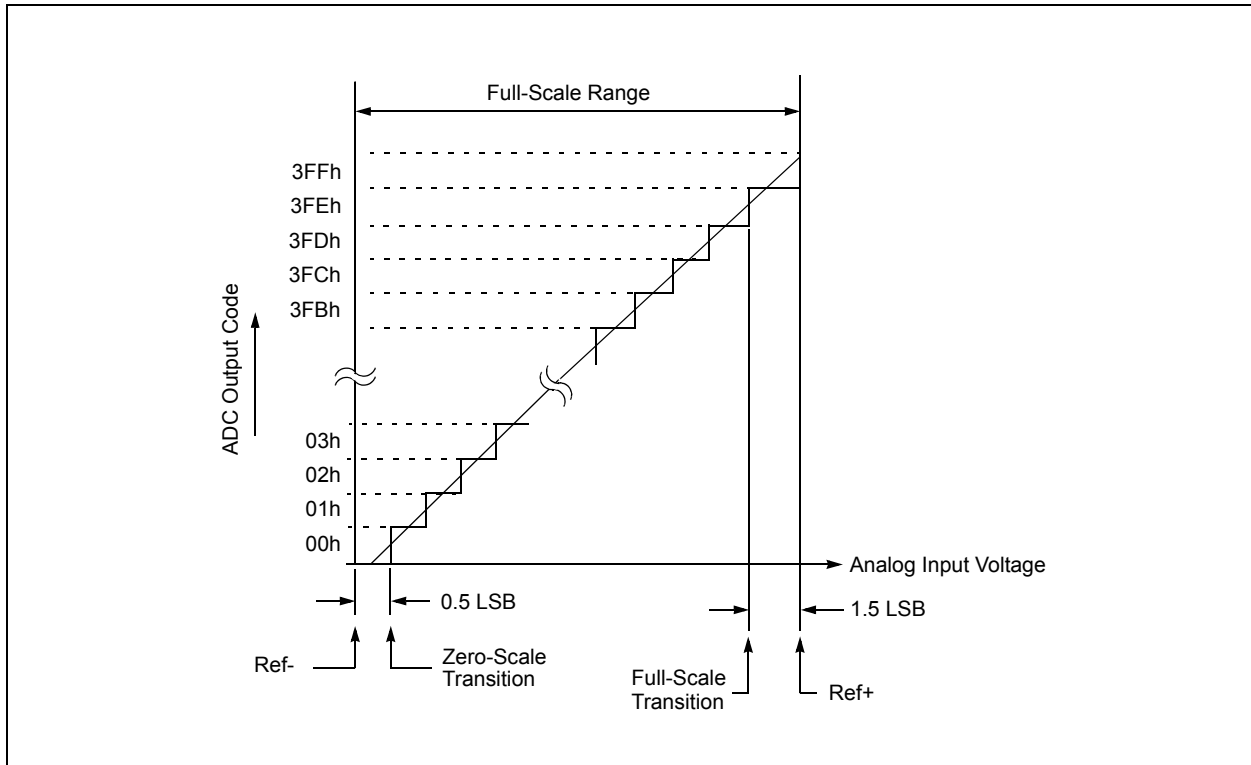
**2:** The Charge Holding Capacitor (CHOLD) is not discharged after each conversion.

**3:** The maximum recommended impedance for analog sources is 10 kΩ. This is required to meet the pin leakage specification.

**FIGURE 16-4: ANALOG INPUT MODEL**



**FIGURE 16-5: ADC TRANSFER FUNCTION**



# PIC16(L)F1764/5/8/9

**TABLE 16-3: SUMMARY OF REGISTERS ASSOCIATED WITH ADC**

Name	Bit 7	Bit 6	Bit 5	Bit 4	Bit 3	Bit 2	Bit 1	Bit 0	Register on Page
ADCON0	—	CHS<4:0>					GO/DONE	ADON	<a href="#">180</a>
ADCON1	ADFM	ADCS<2:0>		—	ADNREF	ADPREF<1:0>			<a href="#">181</a>
ADCON2	TRIGSEL<4:0>				—	—	—		<a href="#">182</a>
ADRESH	ADC Result Register High								<a href="#">183, 184</a>
ADRESL	ADC Result Register Low								<a href="#">183, 184</a>
ANSELA	—	—	—	ANSA4	—	ANSA<2:0>			<a href="#">139</a>
ANSELB <sup>(1)</sup>	ANSB<7:6>		ANSB<5:4>		—	—	—	—	<a href="#">145</a>
ANSELC	ANSC<7:6> <sup>(1)</sup>		—	—	ANSC<3:0>				<a href="#">150</a>
INTCON	GIE	PEIE	TMR0IE	INTE	IOCIE	TMR0IF	INTF	IOCIF	<a href="#">101</a>
PIE1	TMR1GIE	ADIE	RCIE	TXIE	SSP1IE	CCP1IE	TMR2IE	TMR1IE	<a href="#">102</a>
PIR1	TMR1GIF	ADIF	RCIF	TXIF	SSP1IF	CCP1IF	TMR2IF	TMR1IF	<a href="#">106</a>
TRISA	—	—	TRISA5	TRISA4	— <sup>(2)</sup>	TRISA<2:0>			<a href="#">138</a>
TRISB <sup>(1)</sup>	TRISB<7:6>		TRISB<5:4>		—	—	—	—	<a href="#">144</a>
TRISC	TRISC<7:6> <sup>(1)</sup>		TRISC<5:4>		TRISC<3:0>				<a href="#">149</a>
FVRCON	FVREN	FVRRDY	TSEN	TSRNG	CDAFVR<1:0>		ADFVR<1:0>		<a href="#">171</a>
DAC1CON0	EN	FM	OE1	—	PSS<1:0>		NSS<1:0>		<a href="#">190</a>

**Legend:** — = unimplemented location, read as '0'. Shaded cells are not used for the ADC module.

**Note 1:** PIC16(L)F1768/9 only.

**2:** Unimplemented, read as '1'.

## 17.0 5-BIT DIGITAL-TO-ANALOG CONVERTER (DAC) MODULE

The Digital-to-Analog Converter supplies a variable voltage reference, ratiometric with the input source, with 32 selectable output levels.

The input of the DAC can be connected to:

- External VREF pins
- VDD supply voltage
- FVR (Fixed Voltage Reference)

The output of the DAC can be configured to supply a reference voltage to the following:

- Comparator positive input
- Operational amplifier inverting and noninverting inputs
- ADC input channel
- DACxOUT1 pin

TABLE 17-1: AVAILABLE 5-BIT DACs

Device	D3	D4
PIC16(L)F1764	•	
PIC16(L)F1765	•	
PIC16(L)F1768	•	•
PIC16(L)F1769	•	•

The Digital-to-Analog Converter (DAC) is enabled by setting the EN bit of the DACxCON0 register.

### 17.1 Output Voltage Selection

The DAC has 32 voltage level ranges. The 32 levels are set with the REF<4:0> bits of the DACxREF register.

The DAC output voltage is determined by [Equation 17-1](#).

EQUATION 17-1: DAC OUTPUT VOLTAGE

*IF DACxEN = 1:*

$$V_{OUT} = \left( (V_{SOURCE+} - V_{SOURCE-}) \times \frac{DACxR[4:0]}{2^5} \right) + V_{SOURCE-}$$

$V_{SOURCE+} = V_{DD}, V_{REF}, \text{ or } FVR \text{ Buffer}2$

$V_{SOURCE-} = V_{SS}$

### 17.2 Ratiometric Output Level

The DAC output value is derived using a resistor ladder with each end of the ladder tied to a positive and negative voltage reference input source. If the voltage of either input source fluctuates, a similar fluctuation will result in the DAC output value.

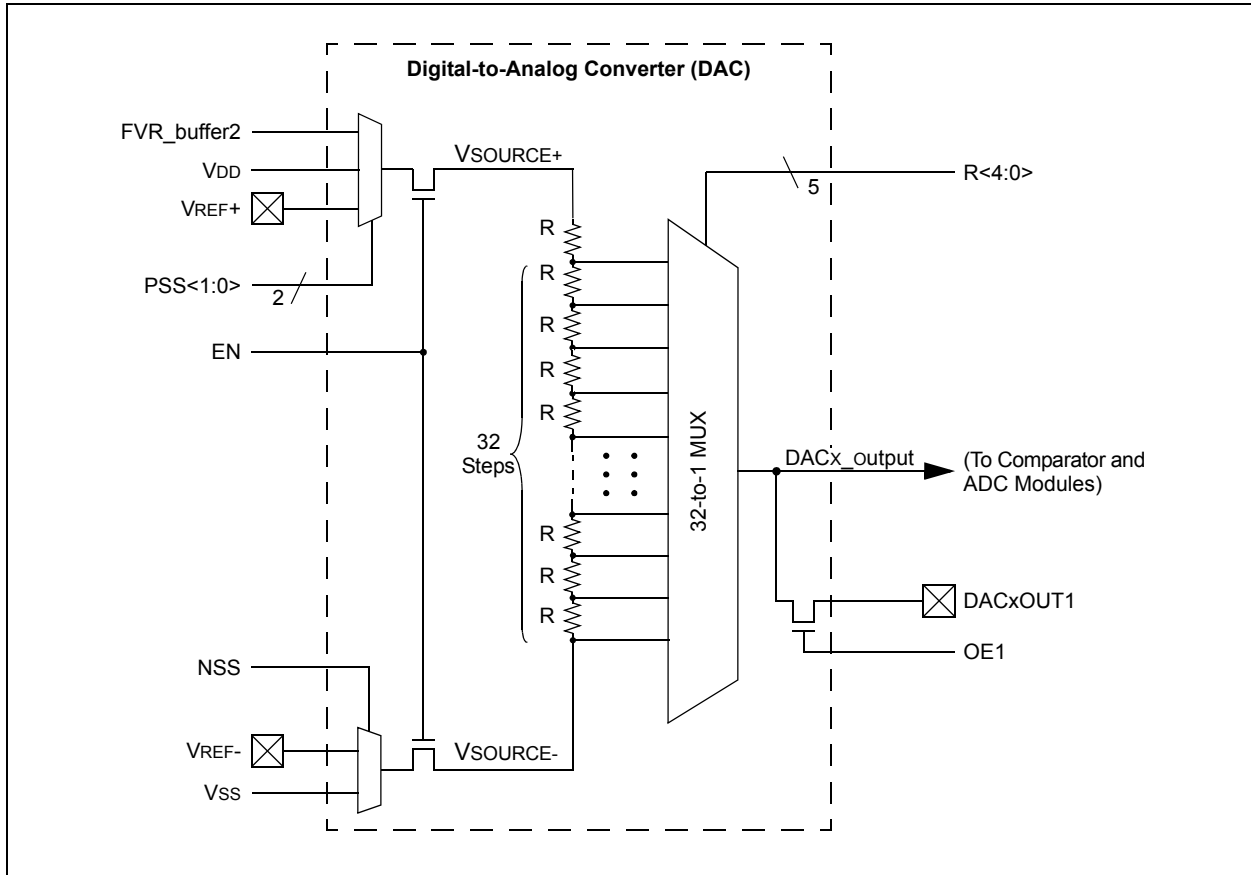
The value of the individual resistors within the ladder can be found in [Table 36-20](#).

### 17.3 DAC Voltage Reference Output

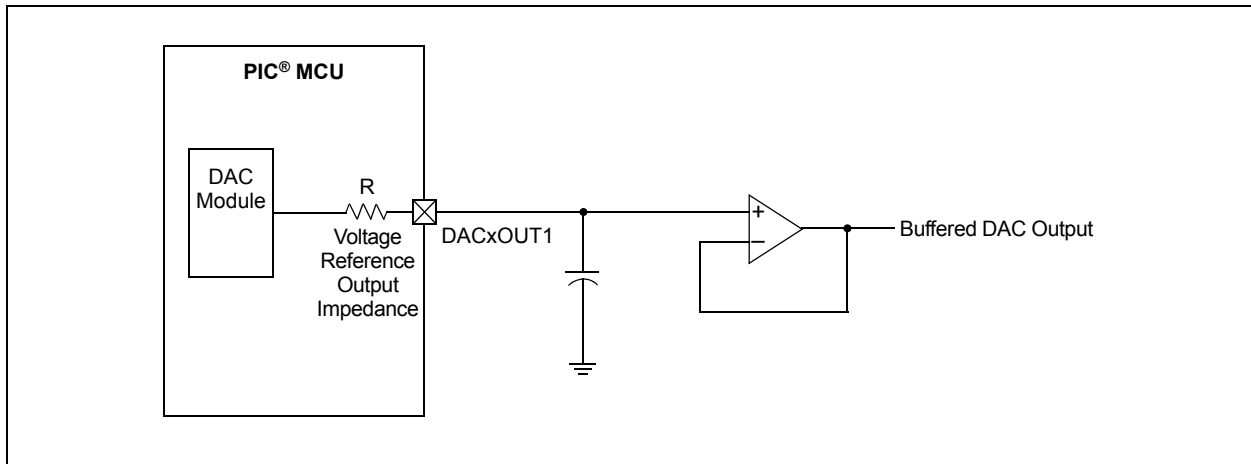
The DAC voltage can be output to the DACxOUT1 pin by setting the OE1 bit of the DACxCON0 register. Selecting the DAC voltage for output on the DACxOUT1 pin automatically overrides the digital output buffer and digital input threshold detector functions of that pin. Reading the DACxOUT1 pin when it has been configured for DAC voltage output will always return a '0'.

Due to the limited current drive capability, a buffer must be used on the DAC voltage output for external connections to the DACxOUT1 pin. [Figure 17-2](#) shows an example buffering technique.

**FIGURE 17-1: DIGITAL-TO-ANALOG CONVERTER BLOCK DIAGRAM**



**FIGURE 17-2: VOLTAGE REFERENCE OUTPUT BUFFER EXAMPLE**



## 17.4 Operation During Sleep

The DAC continues to function during Sleep. When the device wakes up from Sleep through an interrupt or a Watchdog Timer time-out, the contents of the DACxCON0 register are not affected. To minimize current consumption in Sleep mode, the voltage reference should be disabled.

## 17.5 Effects of a Reset

A device Reset affects the following:

- DAC is disabled.
- DAC output voltage is removed from the DACxOUT1 pin.
- The REF<4:0> voltage reference control bits are cleared.

## 17.6 Register Definitions: DAC Control

Long bit name prefixes for the 5-bit DAC peripherals are shown in Table 17-2. Refer to Section 1.1 “Register and Bit Naming Conventions” for more information.

**TABLE 17-2: BIT NAME PREFIXES**

Peripheral	Bit Name Prefix
DAC3	DAC3
DAC4 <sup>(1)</sup>	DAC4

**Note 1:** PIC16(L)F1768/9 devices only.

### REGISTER 17-1: DACxCON0: DACx CONTROL REGISTER 0

R/W-0/0	U-0	R/W-0/0	U-0	R/W-0/0	R/W-0/0	U-0	R/W-0/0
EN	—	OE1	—	PSS<1:0>		—	NSS
bit 7							bit 0

**Legend:**

R = Readable bit

W = Writable bit

u = Bit is unchanged

x = Bit is unknown

U = Unimplemented bit, read as '0'

'1' = Bit is set

'0' = Bit is cleared

-n/n = Value at POR and BOR/Value at all other Resets

- bit 7      **EN:** DACx Enable bit  
1 = DACx is enabled  
0 = DACx is disabled
- bit 6      **Unimplemented:** Read as '0'
- bit 5      **OE1:** DACx Voltage Output Enable bit  
1 = DACx voltage level is also an output on the DACxOUT1 pin  
0 = DACx voltage level is disconnected from the DACxOUT1 pin
- bit 4      **Unimplemented:** Read as '0'
- bit 3-2    **PSS<1:0>:** DACx Positive Source Select bits  
11 = Reserved, do not use  
10 = FVR Buffer2 output  
01 = VREF+ pin  
00 = VDD
- bit 1      **Unimplemented:** Read as '0'
- bit 0      **NSS:** DACx Negative Source Select bit  
1 = VREF- pin  
0 = VSS

# PIC16(L)F1764/5/8/9

**REGISTER 17-2: DACxREF: DACx REFERENCE VOLTAGE OUTPUT SELECT REGISTER**

U-0	U-0	U-0	R/W-0/0	R/W-0/0	R/W-0/0	R/W-0/0	R/W-0/0
—	—	—	REF<4:0>				
bit 7							bit 0

**Legend:**

R = Readable bit                      W = Writable bit  
u = Bit is unchanged                  x = Bit is unknown                  U = Unimplemented bit, read as '0'  
'1' = Bit is set                          '0' = Bit is cleared                  -n/n = Value at POR and BOR/Value at all other Resets

bit 7-5                      **Unimplemented:** Read as '0'  
bit 4-0                      **REF<4:0>:** DACx Reference Voltage Output Select bits (see [Equation 17-1](#))

**TABLE 17-3: SUMMARY OF REGISTERS ASSOCIATED WITH THE DACx MODULE**

Name	Bit 7	Bit 6	Bit 5	Bit 4	Bit 3	Bit 2	Bit 1	Bit 0	Register on Page
DAC3CON0	EN	—	OE1	—	PSS<1:0>		—	NSS	<a href="#">190</a>
DAC4CON0 <sup>(1)</sup>	EN	---	OE1	---	PSS<1:0>		---	NSS	<a href="#">190</a>
DAC3REF	---	---	---	REF<4:0>					<a href="#">191</a>
DAC4REF <sup>(1)</sup>	---	---	---	REF<4:0>					<a href="#">191</a>

**Legend:** — = unimplemented location, read as '0'. Shaded cells are not used with the DACx module.

**Note 1:** PIC16(L)F1768/9 only.

## 18.0 10-BIT DIGITAL-TO-ANALOG CONVERTER (DAC) MODULE

The 10-bit Digital-to-Analog Converter (DAC) supplies a variable voltage reference, ratiometric with the input source, with 1024 selectable output levels.

The input of the DAC can be connected to:

- External VREF pins
- VDD supply voltage
- FVR (Fixed Voltage Reference)

The output of the DAC can be configured to supply a reference voltage to the following:

- Comparator positive input
- ADC input channel
- DACxOUT1 pin
- Op Amp

The Digital-to-Analog Converter is enabled by setting the EN bit of the DACxCON0 register.

TABLE 18-1: AVAILABLE 10-BIT DACs

Device	D1	D2
PIC16(L)F1764	•	
PIC16(L)F1765	•	
PIC16(L)F1768	•	•
PIC16(L)F1769	•	•

### 18.1 Output Voltage Level Selection

The DAC has 1024 voltage levels that are set by the 10-bit reference selection word contained in the DACxREFH and DACxREFL registers. This 10-bit word can be left or right justified. See [Section 18.4 “DAC Reference Selection Justification”](#) for more details.

The DAC output voltage can be determined with [Equation 18-1](#).

EQUATION 18-1: DAC OUTPUT VOLTAGE

$$\begin{aligned}
 & \text{If } EN = 1: \\
 & DACx\_output = \left( (VSOURCE+ - VSOURCE-) \times \frac{DACxR[9:0]}{2^{10}} \right) + VSOURCE- \\
 & VSOURCE+ = VDD, VREF+, \text{ or } FVR\_buffer2 \\
 & VSOURCE- = VSS \text{ OR } VREF-
 \end{aligned}$$

### 18.2 Ratiometric Output Voltage

The DAC output voltage is derived using a resistor ladder with each end of the ladder tied to a positive and negative voltage source. If the voltage of either input source fluctuates, a similar fluctuation will result in the DAC output value.

The value of the individual resistors within the ladder can be found in [Table 36-20](#).

### 18.3 DAC Output

The DAC voltage is always available to the internal peripherals that use it. The DAC voltage can be output to the DACxOUT1 pin by setting the OE1 bit of the DACxCON0 register. Selecting the DAC voltage for output on the DACxOUT1 pin automatically overrides the digital output buffer and digital input threshold detector functions of that pin. Reading the DACxOUT1 pin when it has been configured for DAC voltage output will always return a '0'.

Due to the limited current drive capability, a buffer must be used on the DAC voltage output for external connections to either DACxOUT1 pin. [Figure 18-3](#) shows a buffering technique example.

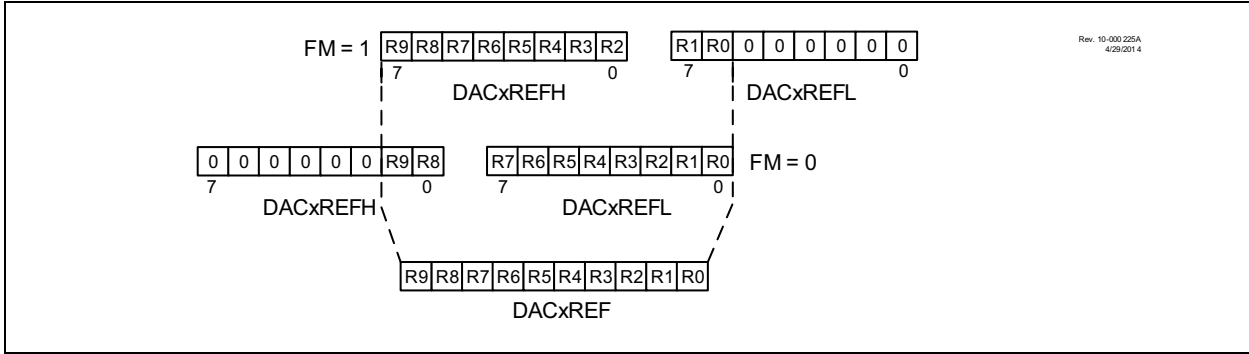
### 18.4 DAC Reference Selection Justification

The DAC reference selection can be configured to be left or right justified. When the FM bit of the DACxCON0 register is set, the 10-bit word is left justified, such that the eight Most Significant bits fill the DACxREFH register and the two Least Significant bits are left justified in the DACxREFL register. When the FM bit is cleared, the 10-bit word is right justified, such that the eight Least Significant bits fill the DACxREFL register and the two Most Significant bits are right justified in the DACxREFH register. Refer to [Figure 18-1](#).

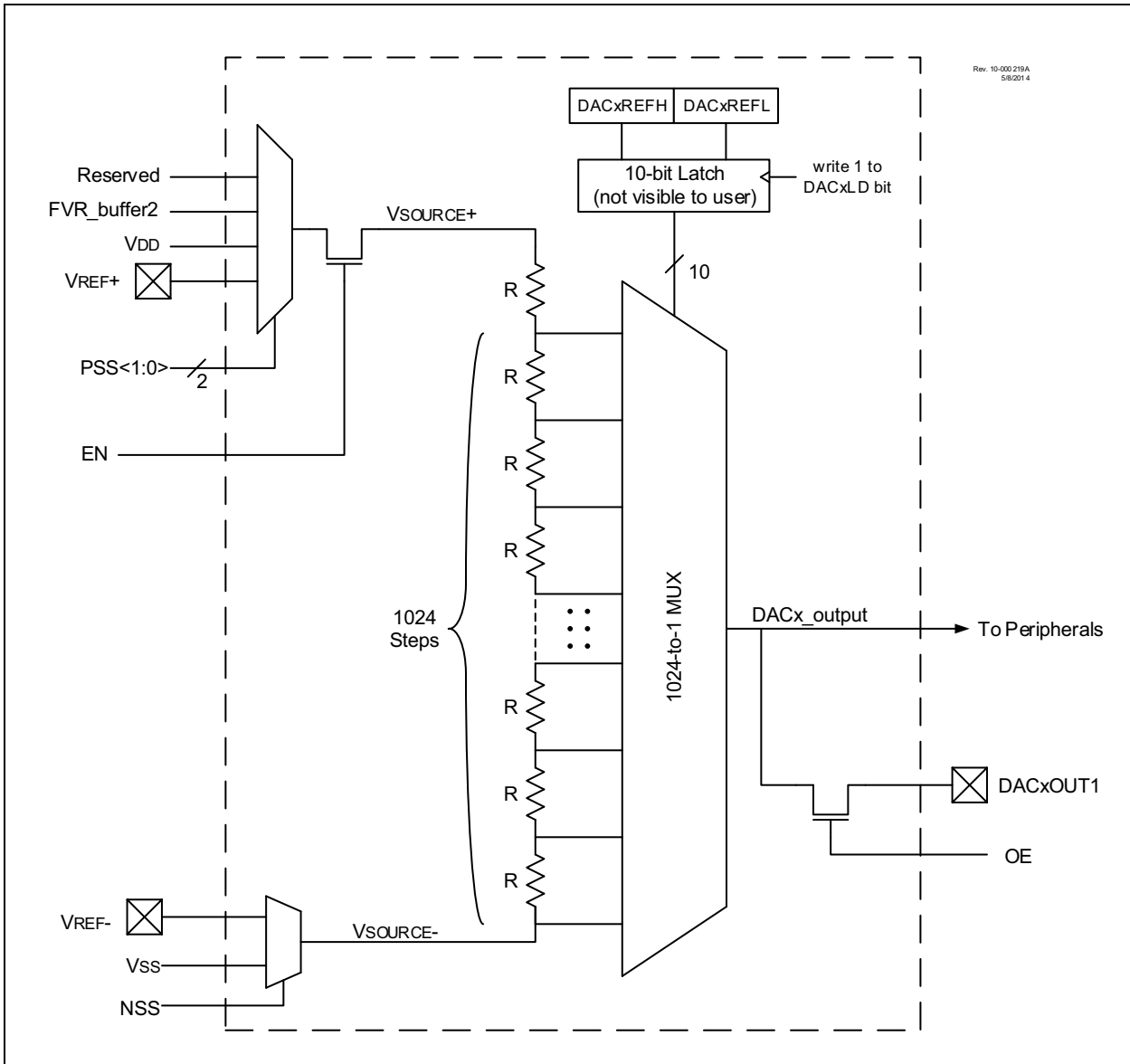
The DACxREFL and DACxREFH registers are double-buffered. Writing to either register does not take effect immediately. Writing a '1' to the DACxLD bit of the DACLD register transfers the contents of the DACxREFH and DACxREFL registers to the buffers, thereby changing all 10 bits of the DAC reference selection simultaneously.



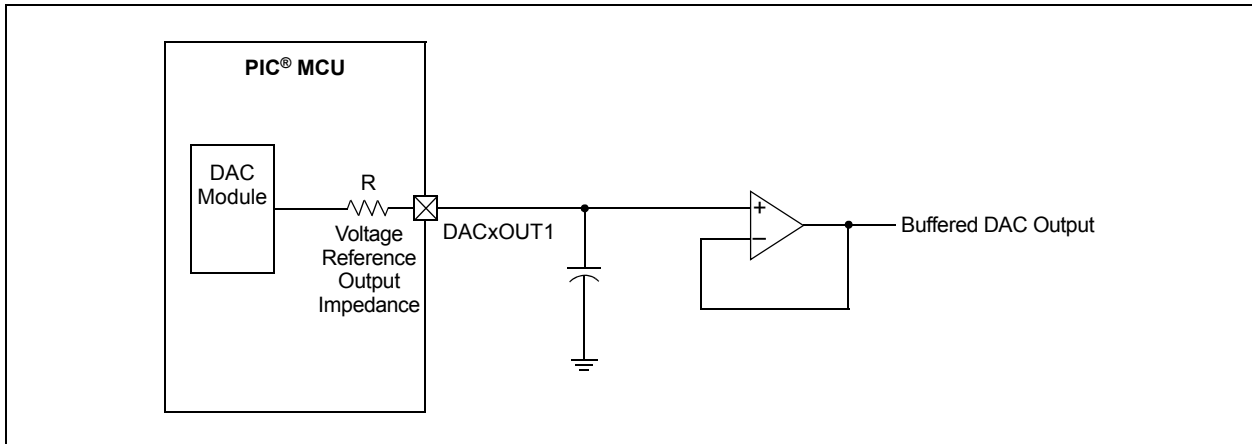
**FIGURE 18-1: DAC JUSTIFICATION**



**FIGURE 18-2: DIGITAL-TO-ANALOG CONVERTER BLOCK DIAGRAM**



**FIGURE 18-3: VOLTAGE REFERENCE OUTPUT BUFFER EXAMPLE**



## 18.5 Operation During Sleep

When the device wakes up from Sleep as the result of an interrupt or a Watchdog Timer time-out, the contents of the DACxCON0 register are not affected. To minimize current consumption in Sleep mode, the voltage reference should be disabled.

## 18.6 Effects of a Reset

A device Reset affects the following:

- DAC is disabled
- DAC output voltage is removed from the DACxOUT1 pin
- The REF<9:0> reference selection bits are cleared

## 18.7 Register Definitions: DAC Control

Long bit name prefixes for the 10-bit DAC peripherals are shown in Table 18-2. Refer to Section 1.1 “Register and Bit Naming Conventions” for more information.

**TABLE 18-2: BIT NAME PREFIXES**

Peripheral	Bit Name Prefix
DAC1	DAC1
DAC2 <sup>(1)</sup>	DAC2

**Note 1:** PIC16(L)F1768/9 devices only.

### REGISTER 18-1: DACxCON0: DACx CONTROL REGISTER 0

R/W-0/0	R/W-0/0	R/W-0/0	U-0	R/W-0/0	R/W-0/0	U-0	R/W-0/0
EN	FM	OE1	—	PSS<1:0>		—	NSS
bit 7							bit 0

**Legend:**

R = Readable bit	W = Writable bit	
u = Bit is unchanged	x = Bit is unknown	U = Unimplemented bit, read as '0'
'1' = Bit is set	'0' = Bit is cleared	-n/n = Value at POR and BOR/Value at all other Resets

- bit 7      **EN:** DACx Enable bit  
1 = DACx is enabled  
0 = DACx is disabled
- bit 6      **FM:** DACx Reference Format bit  
1 = DACx reference selection is left justified  
0 = DACx reference selection is right justified
- bit 5      **OE1:** DACx Voltage Output Enable bit  
1 = DACx voltage level is also an output on the DACxOUT1 pin  
0 = DACx voltage level is disconnected from the DACxOUT1 pin
- bit 4      **Unimplemented:** Read as '0'
- bit 3-2    **PSS<1:0>:** DACx Positive Source Select bits  
11 = Reserved; do not use.  
10 = FVR\_buffer2  
01 = VREF+ pin  
00 = VDD
- bit 1      **Unimplemented:** Read as '0'
- bit 0      **NSS:** DACx Negative Source Select bit  
1 = VREF- pin  
0 = VSS

## REGISTER 18-2: DACxREFH: DACx REFERENCE VOLTAGE SELECT HIGH REGISTER

R/W-0/0	R/W-0/0	R/W-0/0	R/W-0/0	R/W-0/0	R/W-0/0	R/W-0/0	R/W-0/0
REF<9:x> (x Depends on FM bit)							
bit 7							bit 0

### Legend:

R = Readable bit	W = Writable bit	
u = Bit is unchanged	x = Bit is unknown	U = Unimplemented bit, read as '0'
'1' = Bit is set	'0' = Bit is cleared	-n/n = Value at POR and BOR/Value at all other Resets

### When FM = 1 (left justified):

bit 7-0      **REF<9:2>**: DAC Reference Voltage Output Select bits  
 DACxOUT1 = f(REF<9:0>) (see [Equation 18-1](#)).

### When FM = 0 (right justified):

bit 7-2      **Unimplemented**: Read as '0'  
 bit 1-0      **REF<9:8>**: DAC Reference Voltage Output Select bits  
 DACxOUT1 = f(REF<9:0>) (see [Equation 18-1](#)).

## REGISTER 18-3: DACxREFL: DACx REFERENCE VOLTAGE SELECT LOW REGISTER

R/W-0/0	R/W-0/0	R/W-0/0	R/W-0/0	R/W-0/0	R/W-0/0	R/W-0/0	R/W-0/0
REF<x-1:0> (x Depends on FM bit)							
bit 7							bit 0

### Legend:

R = Readable bit	W = Writable bit	
u = Bit is unchanged	x = Bit is unknown	U = Unimplemented bit, read as '0'
'1' = Bit is set	'0' = Bit is cleared	-n/n = Value at POR and BOR/Value at all other Resets

### When FM = 1 (left justified):

bit 7-6      **REF<1:0>**: DAC Reference Voltage Output Select bits  
 DACxOUT1 = f(REF<9:0>) (see [Equation 18-1](#)).

bit 5-0      **Unimplemented**: Read as '0'

### When FM = 0 (right justified):

bit 7-0      **REF<7:0>**: DAC Reference Voltage Output Select bits  
 DACxOUT1 = f(REF<9:0>) (see [Equation 18-1](#)).

# PIC16(L)F1764/5/8/9

**REGISTER 18-4: DACLD: DAC BUFFER LOAD REGISTER**

U-0	U-0	U-0	U-0	U-0	U-0	R/W-0/0	R/W-0/0
—	—	—	—	—	—	DAC2LD <sup>(1)</sup>	DAC1LD
bit 7						bit 0	

**Legend:**

R = Readable bit	W = Writable bit	U = Unimplemented bit, read as '0'
u = Bit is unchanged	x = Bit is unknown	-n/n = Value at POR and BOR/Value at all other Resets
'1' = Bit is set	'0' = Bit is cleared	q = value depends on configuration bits

bit 7-2 **Unimplemented:** Read as '0'

bit 1 **DAC2LD:** DAC2 Double-Buffer Load bit<sup>(1)</sup>

1 = DAC2REFH:DAC2REFL values are transferred to the double-buffer; bit is cleared automatically by hardware

0 = DAC2REFH:DAC2REFL double-buffers remain unchanged

bit 0 **DAC1LD:** DAC1 Double-Buffer Load bit

1 = DAC1REFH:DAC1REFL values are transferred to the double-buffer; bit is cleared automatically by hardware

0 = DAC1REFH:DAC1REFL double-buffers remain unchanged

**Note 1:** PIC16(L)F1768/9 only

**TABLE 18-3: SUMMARY OF REGISTERS ASSOCIATED WITH THE DACx MODULE**

Name	Bit 7	Bit 6	Bit 5	Bit 4	Bit 3	Bit 2	Bit 1	Bit 0	Register on Page
DAC1CON0	EN	FM	OE1	—	PSS<1:0>	—	—	NSS	195
DAC2CON0 <sup>(1)</sup>	EN	FM	OE1	—	PSS<1:0>	—	—	NSS	195
DAC1REFH	REF<9:x> (x Depends on FM bit)								196
DAC2REFH <sup>(1)</sup>	REF<9:x> (x Depends on FM bit)								196
DAC1REFL	REF<x-1:0> (x Depends on FM bit)								196
DAC2REFL <sup>(1)</sup>	REF<x-1:0> (x Depends on FM bit)								196
DACLD	—	—	—	—	—	—	DAC2LD <sup>(1)</sup>	DAC1LD	197

**Legend:** — = unimplemented location, read as '0'. Shaded cells are not used with the DACx module.

**Note 1:** PIC16(L)F1768/9 only

## 19.0 COMPARATOR MODULE

Comparators are used to interface analog circuits to a digital circuit by comparing two analog voltages and providing a digital indication of their relative magnitudes. Comparators are very useful mixed-signal building blocks because they provide analog functionality independent of program execution. The analog comparator module includes the following features:

- Independent comparator control
- Programmable input selection
- Comparator output is available internally/externally
- Programmable output polarity
- Interrupt-On-Change
- Wake-up from Sleep
- Programmable speed/power optimization
- PWM shutdown
- Programmable and Fixed Voltage Reference (FVR)

### 19.1 Comparator Overview

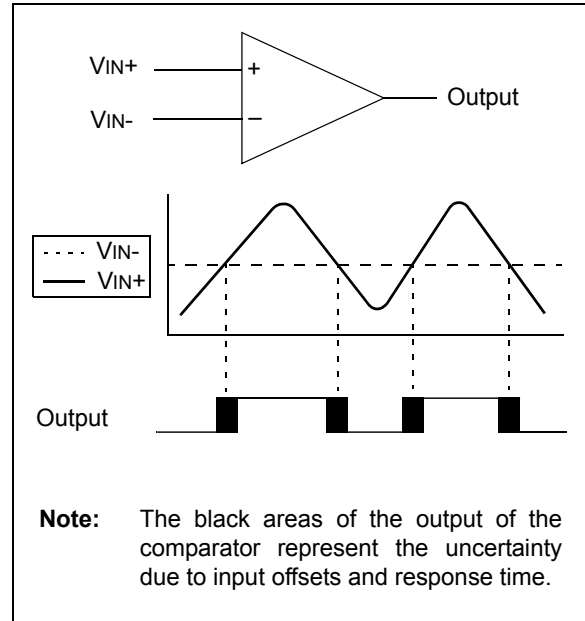
A single comparator is shown in [Figure 19-1](#) along with the relationship between the analog input levels and the digital output. When the analog voltage at  $V_{IN+}$  is less than the analog voltage at  $V_{IN-}$ , the output of the comparator is a digital low level. When the analog voltage at  $V_{IN+}$  is greater than the analog voltage at  $V_{IN-}$ , the output of the comparator is a digital high level.

The comparators available for this device are located in [Table 19-1](#).

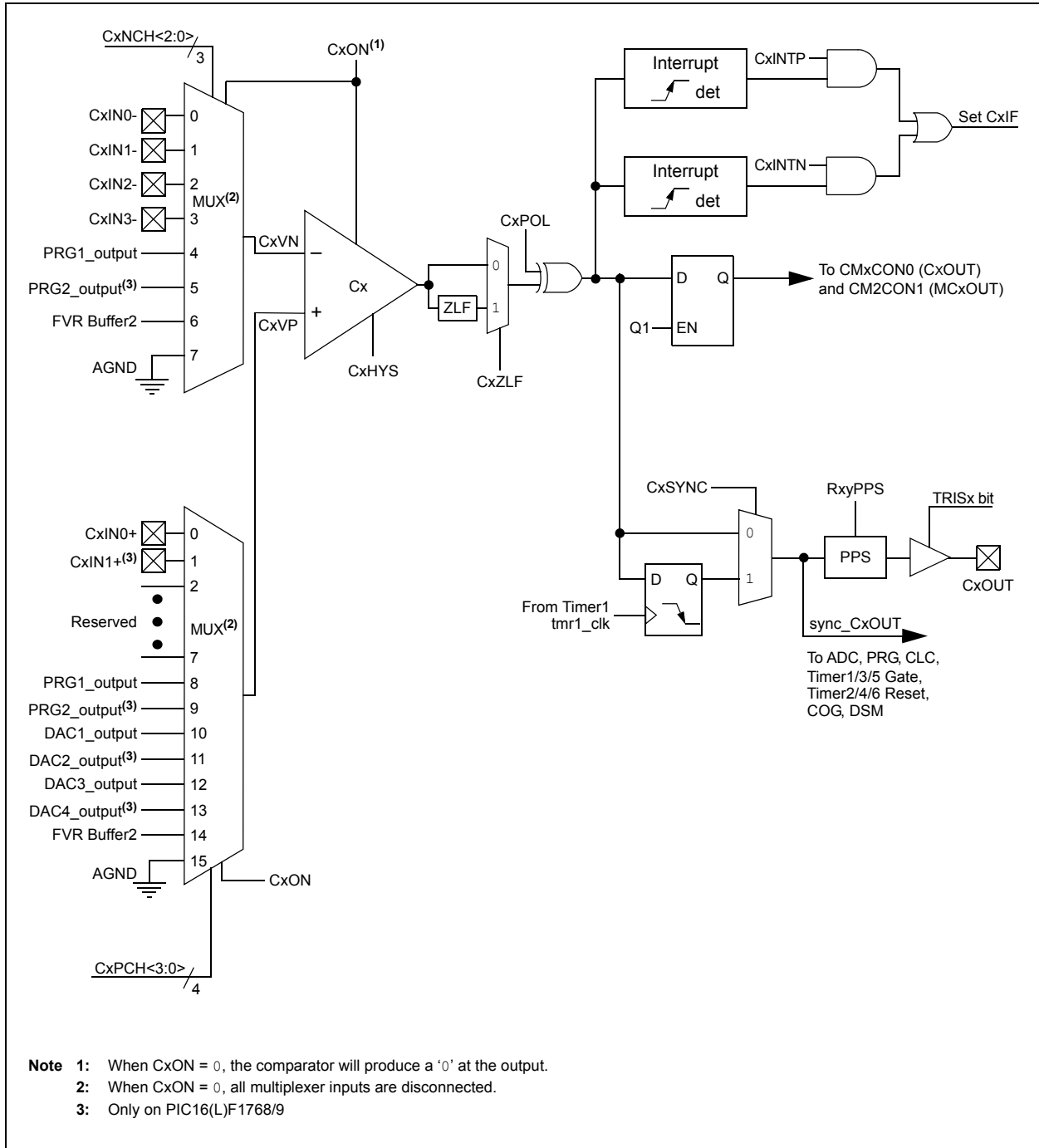
**TABLE 19-1: AVAILABLE COMPARATORS**

Device	C1	C2	C3	C4
PIC16(L)F1764	•	•		
PIC16(L)F1765	•	•		
PIC16(L)F1768	•	•	•	•
PIC16(L)F1769	•	•	•	•

**FIGURE 19-1: SINGLE COMPARATOR**



**FIGURE 19-2: COMPARATOR MODULE SIMPLIFIED BLOCK DIAGRAM**



## 19.2 Comparator Control

Each comparator has two control registers: CMxCON0 and CMxCON1.

The CMxCON0 register (see [Register 19-1](#)) contains control and status bits for the following:

- Enable
- Output
- Output polarity
- Zero latency filter
- Speed/power selection
- Hysteresis enable
- Output synchronization

The CMxCON1 register (see [Register 19-2](#)) contains control bits for the following:

- Interrupt enable
- Interrupt edge polarity
- Positive input channel selection
- Negative input channel selection

### 19.2.1 COMPARATOR ENABLE

Setting the ON bit of the CMxCON0 register enables the comparator for operation. Clearing the ON bit disables the comparator, resulting in minimum current consumption.

### 19.2.2 COMPARATOR OUTPUT SELECTION

The output of the comparator can be monitored by reading either the OUT bit of the CMxCON0 register or the MCxOUT bit of the CMOUT register. In order to make the output available for an external connection, the following conditions must be true:

- Desired pin PPS control
- Corresponding TRISx bit must be cleared
- ON bit of the CMxCON0 register must be set

**Note 1:** The internal output of the comparator is latched with each instruction cycle. Unless otherwise specified, external outputs are not latched.

### 19.2.3 COMPARATOR OUTPUT POLARITY

Inverting the output of the comparator is functionally equivalent to swapping the comparator inputs. The polarity of the comparator output can be inverted by setting the POL bit of the CMxCON0 register. Clearing the POL bit results in a noninverted output.

[Table 19-2](#) shows the output state versus input conditions, including polarity control.

**TABLE 19-2: COMPARATOR OUTPUT STATE vs. INPUT CONDITIONS**

Input Condition	CxPOL	CxOUT
$CxVN > CxVP$	0	0
$CxVN < CxVP$	0	1
$CxVN > CxVP$	1	1
$CxVN < CxVP$	1	0



## 19.3 Comparator Hysteresis

A selectable amount of separation voltage can be added to the input pins of each comparator to provide a hysteresis function to the overall operation. Hysteresis is enabled by setting the HYS bit of the CMxCON0 register.

See Comparator Specifications in [Table 36-19: Comparator Specifications](#) for more information.

## 19.4 Timer1 Gate Operation

The output resulting from a comparator operation can be used as a source for gate control of Timer1. See [Section 22.6 “Timer1 Gate”](#) for more information. This feature is useful for timing the duration or interval of an analog event.

It is recommended that the comparator output be synchronized to Timer1. This ensures that Timer1 does not increment while a change in the comparator is occurring.

### 19.4.1 COMPARATOR OUTPUT SYNCHRONIZATION

The output from a comparator can be synchronized with Timer1 by setting the SYNC bit of the CMxCON0 register.

Once enabled, the comparator output is latched on the falling edge of the Timer1 source clock. If a prescaler is used with Timer1, the comparator output is latched after the prescaling function. To prevent a race condition, the comparator output is latched on the falling edge of the Timer1 clock source and Timer1 increments on the rising edge of its clock source. See the Comparator Block Diagram ([Figure 19-2](#)) and the Timer1 Block Diagram ([Figure 22-1](#)) for more information.

## 19.5 Comparator Interrupt

An interrupt can be generated upon a change in the output value of the comparator for each comparator, a rising edge detector and a falling edge detector are present.

When either edge detector is triggered and its associated enable bit is set (INTP and/or INTN bits of the CMxCON1 register), the corresponding interrupt flag bit (CxIF bit of the PIR2 register) will be set.

To enable the interrupt, you must set the following bits:

- ON and POL bits of the CMxCON0 register
- CxIE bit of the PIE2 register
- INTP bit of the CMxCON1 register (for a rising edge detection)
- INTN bit of the CMxCON1 register (for a falling edge detection)
- PEIE and GIE bits of the INTCON register

The associated interrupt flag bit, CxIF bit of the PIR2 register, must be cleared in software. If another edge is detected while this flag is being cleared, the flag will still be set at the end of the sequence.

**Note:** Although a comparator is disabled, an interrupt can be generated by changing the output polarity with the POL bit of the CMxCON0 register, or by switching the comparator on or off with the ON bit of the CMxCON0 register.

## 19.6 Comparator Positive Input Selection

Configuring the PCH<3:0> bits of the CMxPSEL register directs an internal voltage reference or an analog pin to the noninverting input of the comparator:

- CxIN+ analog pin
- Programmable Ramp Generator (PRG) output
- DAC output
- FVR (Fixed Voltage Reference)
- Vss (Ground)

See [Section 14.0 “Fixed Voltage Reference \(FVR\)”](#) for more information on the Fixed Voltage Reference module.

See [Section 17.0 “5-Bit Digital-to-Analog Converter \(DAC\) Module”](#) for more information on the DAC input signal.

Any time the comparator is disabled (CxON = 0), all comparator inputs are disabled.

## 19.7 Comparator Negative Input Selection

The NCH<2:0> bits of the CMxNSEL register direct an analog input pin and internal reference voltage or analog ground to the inverting input of the comparator:

- CxIN- pin
- FVR (Fixed Voltage Reference)
- Analog ground

Some inverting input selections share a pin with the operational amplifier output function. Enabling both functions at the same time will direct the operational amplifier output to the comparator inverting input.

**Note:** To use CxINy+ and CxINy- pins as analog inputs, the appropriate bits must be set in the ANSELx register and the corresponding TRISx bits must also be set to disable the output drivers.

## 19.8 Comparator Response Time

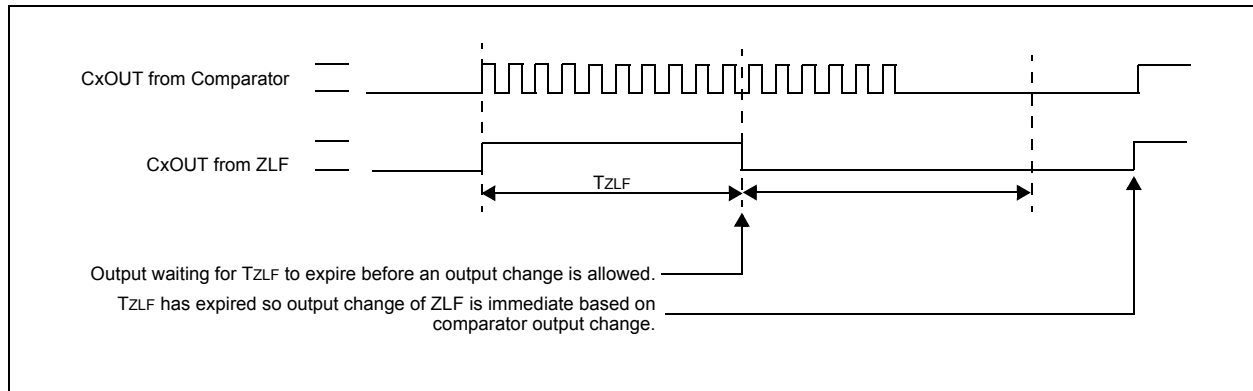
The comparator output is indeterminate for a period of time after the change of an input source or the selection of a new reference voltage. This period is referred to as the response time. The response time of the comparator differs from the settling time of the voltage reference. Therefore, both of these times must be considered when determining the total response time to a comparator input change. See the Comparator and Voltage Reference Specifications in [Table 36-19: Comparator Specifications](#) for more details.

the hardware and software relying on this signal. Therefore, a digital filter has been added to the comparator output to suppress the comparator output oscillation. Once the comparator output changes, the output is prevented from reversing the change for a nominal time of 20 ns. This allows the comparator output to stabilize without affecting other dependent devices. Refer to [Figure 19-3](#).

## 19.9 Zero Latency Filter

In high-speed operation, and under proper circuit conditions, it is possible for the comparator output to oscillate. This oscillation can have adverse effects on

**FIGURE 19-3: COMPARATOR ZERO LATENCY FILTER OPERATION**



## 19.10 Analog Input Connection Considerations

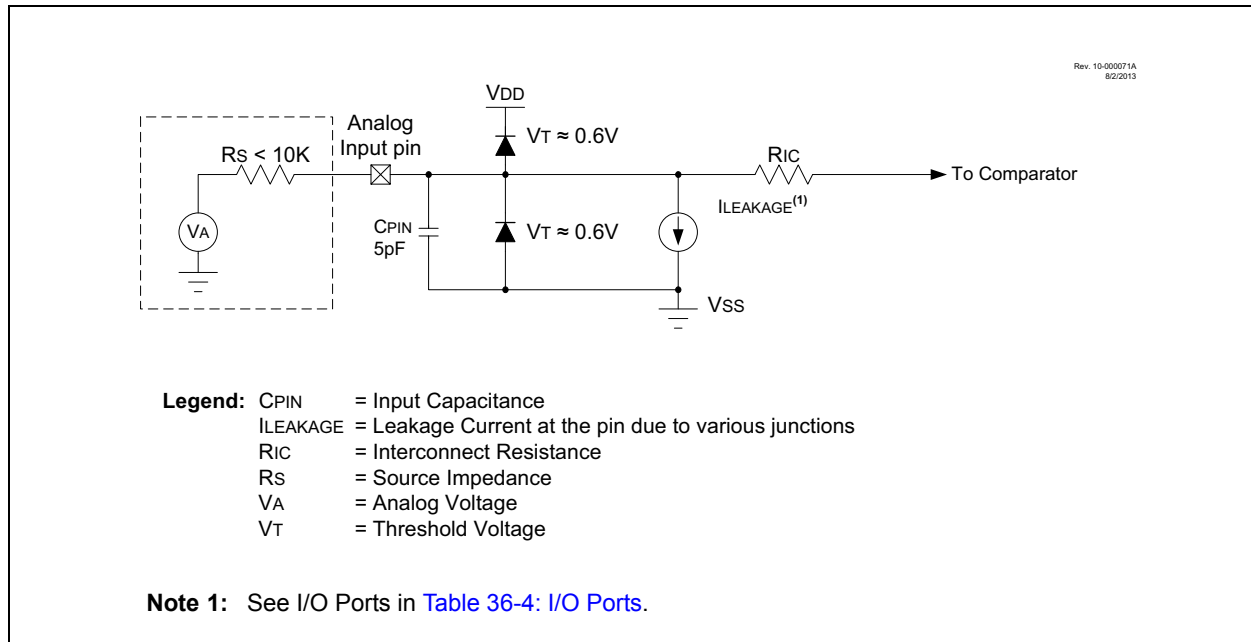
A simplified circuit for an analog input is shown in Figure 19-4. Since the analog input pins share their connection with a digital input, they have reverse biased ESD protection diodes to  $V_{DD}$  and  $V_{SS}$ . The analog input, therefore, must be between  $V_{SS}$  and  $V_{DD}$ . If the input voltage deviates from this range by more than 0.6V in either direction, one of the diodes is forward biased and a latch-up may occur.

A maximum source impedance of 10 k $\Omega$  is recommended for the analog sources. Also, any external component connected to an analog input pin, such as a capacitor or a Zener diode, should have very little leakage current to minimize inaccuracies introduced.

**Note 1:** When reading a PORT register, all pins configured as analog inputs will read as a '0'. Pins configured as digital inputs will convert as an analog input, according to the input specification.

**2:** Analog levels on any pin defined as a digital input, may cause the input buffer to consume more current than is specified.

**FIGURE 19-4: ANALOG INPUT MODEL**



## 19.11 Register Definitions: Comparator Control

Long bit name prefixes for the DSM peripherals are shown in [Table 19-3](#). Refer to [Section 1.1.2.2 “Long Bit Names”](#) for more information

**TABLE 19-3: BIT NAME PREFIXES**

Peripheral	Bit Name Prefix
Comparator 1	C1
Comparator 2 <sup>(1)</sup>	C2

**Note 1:** PIC16(L)F1768/9 devices only.

**REGISTER 19-1: CMxCON0: COMPARATOR Cx CONTROL REGISTER 0**

R/W-0/0	R-0/0	U-0	R/W-0/0	R/W-0/0	R/W-1/1	R/W-0/0	R/W-0/0
ON	OUT	—	POL	ZLF	r	HYS	SYNC
bit 7							bit 0

**Legend:**

R = Readable bit	W = Writable bit	r = Reserved bit
u = Bit is unchanged	x = Bit is unknown	U = Unimplemented bit, read as '0'
'1' = Bit is set	'0' = Bit is cleared	-n/n = Value at POR and BOR/Value at all other Resets

bit 7	<b>ON:</b> Comparator Enable bit 1 = Comparator is enabled 0 = Comparator is disabled and consumes no active power
bit 6	<b>OUT:</b> Comparator Output bit <u>If POL = 1 (inverted polarity):</u> 1 = CxVP < CxVN 0 = CxVP > CxVN <u>If POL = 0 (noninverted polarity):</u> 1 = CxVP > CxVN 0 = CxVP < CxVN
bit 5	<b>Unimplemented:</b> Read as '0'
bit 4	<b>POL:</b> Comparator Output Polarity Select bit 1 = Comparator output is inverted 0 = Comparator output is not inverted
bit 3	<b>ZLF:</b> Comparator Zero Latency Filter Enable bit 1 = Comparator output is filtered 0 = Comparator output is unfiltered
bit 2	<b>Reserved:</b> Read as '1'; maintain this bit set
bit 1	<b>HYS:</b> Comparator Hysteresis Enable bit 1 = Comparator hysteresis is enabled 0 = Comparator hysteresis is disabled
bit 0	<b>SYNC:</b> Comparator Output Synchronous Mode bit 1 = Comparator output to Timer1 and I/O pin is synchronous to changes on Timer1 clock source; output updated on the falling edge of Timer1 clock source 0 = Comparator output to Timer1 and I/O pin is asynchronous

# PIC16(L)F1764/5/8/9

**REGISTER 19-2: CMxCON1: COMPARATOR Cx CONTROL REGISTER 1**

U-0	U-0	U-0	U-0	U-0	U-0	R/W-0/0	R/W-0/0
—	—	—	—	—	—	INTP	INTN
bit 7						bit 0	

**Legend:**

R = Readable bit                      W = Writable bit  
u = Bit is unchanged                  x = Bit is unknown                  U = Unimplemented bit, read as '0'  
'1' = Bit is set                          '0' = Bit is cleared                  -n/n = Value at POR and BOR/Value at all other Resets

- bit 7-2            **Unimplemented:** Read as '0'
- bit 1            **INTP:** Comparator Interrupt on Positive Going Edge Enable bit  
1 = The CxIF interrupt flag will be set upon a positive going edge of the CxOUT bit  
0 = No interrupt flag will be set on a positive going edge of the CxOUT bit
- bit 0            **INTN:** Comparator Interrupt on Negative Going Edge Enable bit  
1 = The CxIF interrupt flag will be set upon a negative going edge of the CxOUT bit  
0 = No interrupt flag will be set on a negative going edge of the CxOUT bit

**REGISTER 19-3: CMxNSEL: COMPARATOR Cx NEGATIVE CHANNEL SELECT REGISTER**

U-0	U-0	U-0	U-0	U-0	R/W-0/0	R/W-0/0	R/W-0/0
—	—	—	—	—	NCH<2:0>		
bit 7						bit 0	

**Legend:**

R = Readable bit                      W = Writable bit  
u = Bit is unchanged                  x = Bit is unknown                  U = Unimplemented bit, read as '0'  
'1' = Bit is set                          '0' = Bit is cleared                  -n/n = Value at POR and BOR/Value at all other Resets

- bit 7-3            **Unimplemented:** Read as '0'
- bit 2-0            **NCH<2:0>:** Comparator Negative Input Channel Select bits  
111 = CxVN connects to AGND  
110 = CxVN connects to FVR Buffer2  
101 = CxVN connects to PRG2\_output<sup>(1)</sup>  
100 = CxVN connects to PRG1\_output  
011 = CxVN connects to CxIN3- pin  
010 = CxVN connects to CxIN2- pin  
001 = CxVN connects to CxIN1- pin  
000 = CxVN connects to CxIN0- pin

**Note 1:** PIC16(L)F1768/9 only.

# PIC16(L)F1764/5/8/9

**REGISTER 19-4: CMxPSEL: COMPARATOR Cx POSITIVE CHANNEL SELECT REGISTER 1**

U-0	U-0	U-0	U-0	R/W-0/0	R/W-0/0	R/W-0/0	R/W-0/0
—	—	—	—	PCH<3:0>			
bit 7							bit 0

**Legend:**

R = Readable bit	W = Writable bit	
u = Bit is unchanged	x = Bit is unknown	U = Unimplemented bit, read as '0'
'1' = Bit is set	'0' = Bit is cleared	-n/n = Value at POR and BOR/Value at all other Resets

- bit 7-4      **Unimplemented:** Read as '0'
- bit 3-0      **PCH<3:0>:** Comparator Positive Input Channel Select bits
  - 1111 = CxVP connects to AGND
  - 1110 = CxVP connects to FVR Buffer2
  - 1101 = CxVP connects to DAC4\_output<sup>(1)</sup>
  - 1100 = CxVP connects to DAC3\_output
  - 1011 = CxVP connects to DAC2\_output<sup>(1)</sup>
  - 1010 = CxVP connects to DAC1\_output
  - 1001 = CxVP connects to PRG2\_output<sup>(1)</sup>
  - 1000 = CxVP connects to PRG1\_output
  - 0111 = CxVP unconnected, input floating
  - 0110 = CxVP unconnected, input floating
  - 0101 = CxVP unconnected, input floating
  - 0100 = CxVP unconnected, input floating
  - 0011 = CxVP unconnected, input floating
  - 0010 = CxVP unconnected, input floating
  - 0001 = CxVP connects to CxIN1+ pin
  - 0000 = CxVP connects to CxIN0+ pin

**Note 1:** PIC16(L)F1768/9 only.

**Note:** There are no long and short bit name variants for the following mirror register.

**REGISTER 19-5: CMOUT: COMPARATOR OUTPUT REGISTER**

U-0	U-0	U-0	U-0	R-0/0	R-0/0	R-0/0	R-0/0
—	—	—	—	MC4OUT <sup>(1)</sup>	MC3OUT <sup>(1)</sup>	MC2OUT	MC1OUT
bit 7							bit 0

**Legend:**

R = Readable bit	W = Writable bit	
u = Bit is unchanged	x = Bit is unknown	U = Unimplemented bit, read as '0'
'1' = Bit is set	'0' = Bit is cleared	-n/n = Value at POR and BOR/Value at all other Resets

- bit 7-2      **Unimplemented:** Read as '0'
- bit 3      **MC4OUT:** Mirror Copy of C4OUT bit<sup>(1)</sup>
- bit 2      **MC3OUT:** Mirror Copy of C3OUT bit<sup>(1)</sup>
- bit 1      **MC2OUT:** Mirror Copy of C2OUT bit
- bit 0      **MC1OUT:** Mirror Copy of C1OUT bit

**Note 1:** PIC16(L)F1768/9 only.

# PIC16(L)F1764/5/8/9

**TABLE 19-4: SUMMARY OF REGISTERS ASSOCIATED WITH COMPARATOR MODULE**

Name	Bit 7	Bit 6	Bit 5	Bit 4	Bit 3	Bit 2	Bit 1	Bit 0	Register on Page
ANSELA	—	—	—	ANSA4	—	ANSA2	ANSA<1:0>		139
ANSELB <sup>(1)</sup>	ANSB<7:6>		ANSB<5:4>		—	—	—	—	145
ANSELC	ANSC7 <sup>(1)</sup>	ANSC6 <sup>(1)</sup>	—	—	ANSC<3:0>				150
CM1CON0	ON	OUT	—	POL	ZLF	Reserved	HYS	SYNC	204
CM2CON0	ON	OUT	—	POL	ZLF	Reserved	HYS	SYNC	204
CM3CON0 <sup>(1)</sup>	ON	OUT	—	POL	ZLF	Reserved	HYS	SYNC	204
CM4CON0 <sup>(1)</sup>	ON	OUT	—	POL	ZLF	Reserved	HYS	SYNC	204
CM1CON1	—	—	—	—	—	—	INTP	INTN	205
CM2CON1	—	—	—	—	—	—	INTP	INTN	205
CM3CON1 <sup>(1)</sup>	—	—	—	—	—	—	INTP	INTN	205
CM4CON1 <sup>(1)</sup>	—	—	—	—	—	—	INTP	INTN	205
CM1NSEL	—	—	—	—	—	NCH<2:0>			205
CM2NSEL	—	—	—	—	—	NCH<2:0>			205
CM3NSEL <sup>(1)</sup>	—	—	—	—	—	NCH<2:0>			205
CM4NSEL <sup>(1)</sup>	—	—	—	—	—	NCH<2:0>			205
CM1PSEL	—	—	—	—	PCH<3:0>				206
CM2PSEL	—	—	—	—	PCH<3:0>				206
CM3PSEL <sup>(1)</sup>	—	—	—	—	PCH<3:0>				206
CM4PSEL <sup>(1)</sup>	—	—	—	—	PCH<3:0>				206
CMOUT	—	—	—	—	MC4OUT <sup>(1)</sup>	MC3OUT <sup>(1)</sup>	MC2OUT	MC1OUT	206
FVRCON	FVREN	FVRRDY	TSEN	TSRNG	CDAFVR<1:0>		ADFVR<1:0>		171
DAC1CON0	EN	FM	OE1	—	PSS<1:0>		—	NSS	195
DAC2CON0 <sup>(1)</sup>	EN	FM	OE1	—	PSS<1:0>		—	NSS	195
DAC3CON0	EN	—	OE1	—	PSS<1:0>		—	NSS	190
DAC4CON0 <sup>(1)</sup>	EN	—	OE1	—	PSS<1:0>		—	NSS	190
DAC3REF	---	---	---	REF<4:0>					191
DAC4REF <sup>(1)</sup>	---	---	---	REF<4:0>					191
DAC1REFH	REF<9:x> (x Depends on FM bit)								196
DAC2REFH <sup>(1)</sup>	REF<9:x> (x Depends on FM bit)								196
DAC1REFL	REF<x-1:0> (x Depends on FM bit)								196
DAC2REFL <sup>(1)</sup>	REF<x-1:0> (x Depends on FM bit)								196
INTCON	GIE	PEIE	TMR0IE	INTE	IOCIE	TMR0IF	INTF	IOCIF	101
PIE2	OSFIE	C2IE	C1IE	—	BCL1IE	C4IE <sup>(1)</sup>	C3IE <sup>(1)</sup>	CCP2IE <sup>(1)</sup>	103
PIR2	OSFIF	C2IF	C1IF	—	BCL1IF	C4IF <sup>(1)</sup>	C3IF <sup>(1)</sup>	CCP2IF <sup>(1)</sup>	107
TRISA	—	—	TRISA<5:4>		— <sup>(2)</sup>	TRISA2	TRISA<1:0>		138
TRISB <sup>(1)</sup>	TRISB<7:6>		TRISB<5:4>		—	—	—	—	144
TRISC	TRISC<7:6> <sup>(1)</sup>		TRISC<5:4>		TRISC<3:0>				149

**Legend:** — = unimplemented location, read as '0'. Shaded cells are unused by the comparator module.

**Note 1:** PIC16(L)F1768/9 only.

**2:** Unimplemented, read as '1'.

## 20.0 ZERO-CROSS DETECTION (ZCD) MODULE

The ZCD module detects when an A/C signal crosses through the ground potential. The actual zero-crossing threshold is the zero-crossing reference voltage, ZCPINV, which is typically 0.75V above ground.

The connection to the signal to be detected is through a series current-limiting resistor. The module applies a current source or sink to the ZCD pin to maintain a constant voltage on the pin, thereby preventing the pin voltage from forward biasing the ESD protection diodes. When the applied voltage is greater than the reference voltage, the module sinks current. When the applied voltage is less than the reference voltage, the module sources current. The current source and sink action keeps the pin voltage constant over the full range of the applied voltage. The ZCD module is shown in the simplified block diagram (Figure 20-2).

The ZCD module is useful when monitoring an AC waveform for, but not limited to, the following purposes:

- A/C period measurement
- Accurate long term time measurement
- Dimmer phase delayed drive
- Low EMI cycle switching

## 20.1 External Resistor Selection

The ZCD module requires a current-limiting resistor in series with the external voltage source. The impedance and rating of this resistor depends on the external source peak voltage. Select a resistor value that will drop all of the peak voltage when the current through the resistor is nominally 300  $\mu$ A. Refer to Equation 20-1 and Figure 20-1. Make sure that the ZCD I/O pin internal weak pull-up is disabled so it doesn't interfere with the current source and sink.

### EQUATION 20-1: EXTERNAL RESISTOR

$$R_{series} = \frac{V_{peak}}{3 \times 10^{-4}}$$

FIGURE 20-1: EXTERNAL VOLTAGE

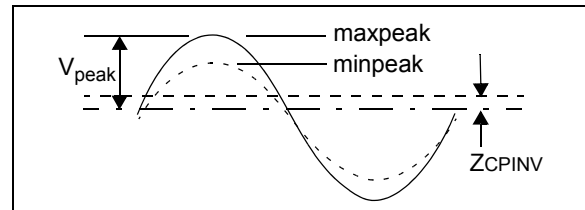
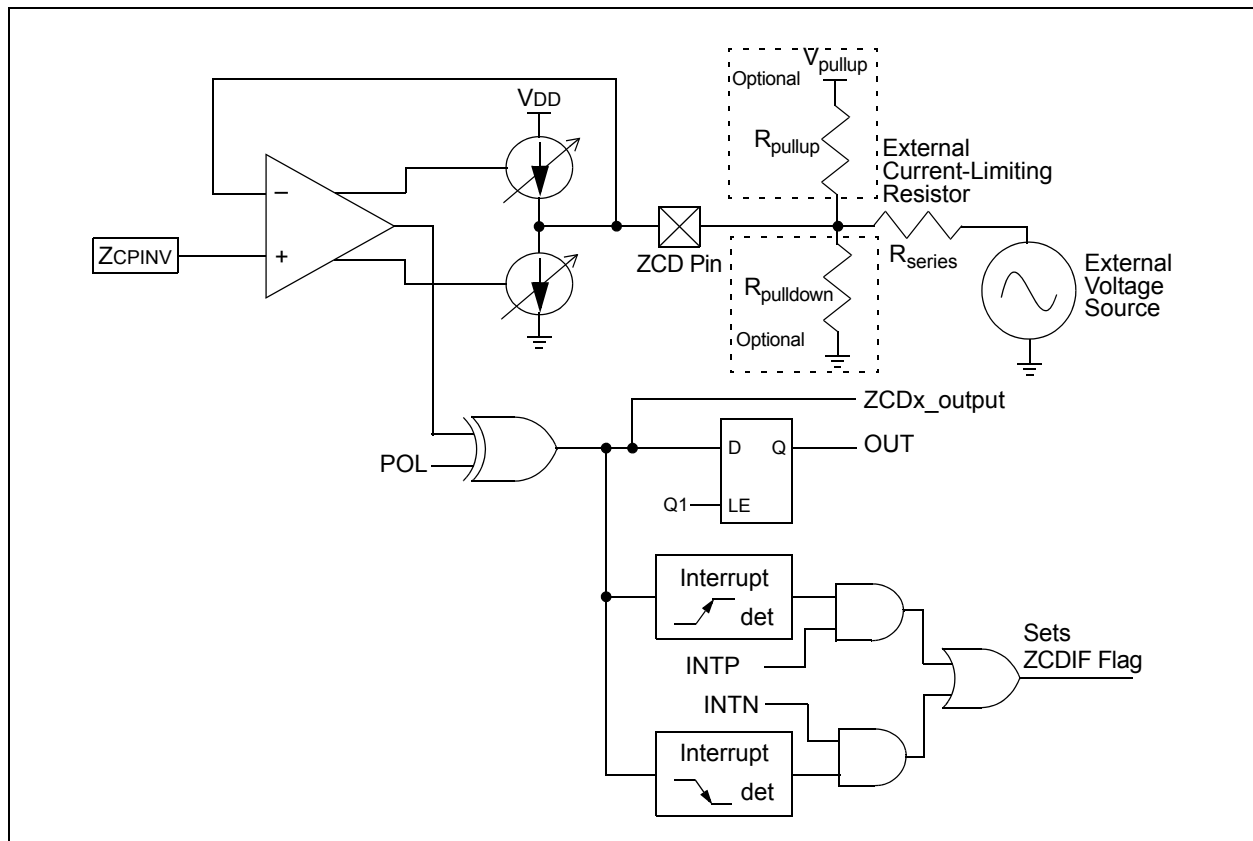


FIGURE 20-2: SIMPLIFIED ZCD BLOCK DIAGRAM





## 20.2 ZCD Logic Output

The ZCD module includes a status bit, which can be read to determine whether the current source or sink is active. The OUT bit of the ZCDxCON register is set when the current sink is active, and cleared when the current source is active. The OUT bit is affected by the polarity bit.

## 20.3 ZCD Logic Polarity

The POL bit of the ZCDxCON register inverts the OUT bit relative to the current source and sink output. When the POL bit is set, a OUT high indicates that the current source is active, and a low output indicates that the current sink is active.

The POL bit affects the ZCD interrupts. See [Section 20.4 “ZCD Interrupts”](#).

## 20.4 ZCD Interrupts

An interrupt will be generated upon a change in the ZCD logic output when the appropriate interrupt enables are set. A rising edge detector and a falling edge detector are present in the ZCD for this purpose.

The ZCDIF bit of the PIR3 register will be set when either edge detector is triggered and its associated enable bit is set. The INTP enables rising edge interrupts and the INTN bit enables falling edge interrupts. Both are located in the ZCDxCON register.

To fully enable the interrupt, the following bits must be set:

- ZCDIE bit of the PIE3 register
- INTP bit of the ZCDxCON register (for a rising edge detection)
- INTN bit of the ZCDxCON register (for a falling edge detection)
- PEIE and GIE bits of the INTCON register

Changing the POL bit will cause an interrupt, regardless of the level of the EN bit.

The ZCDIF bit of the PIR3 register must be cleared in software as part of the interrupt service. If another edge is detected while this flag is being cleared, the flag will still be set at the end of the sequence.

## 20.5 Correcting for ZCPINV Offset

The actual voltage at which the ZCD switches is the reference voltage at the noninverting input of the ZCD op amp. For external voltage source waveforms other than square waves this voltage offset from zero causes the zero-cross event to occur either too early or too late.

### 20.5.1 CORRECTION BY AC COUPLING

When the external voltage source is sinusoidal, the effects of the ZCPINV offset can be eliminated by isolating the external voltage source from the ZCD pin with a capacitor in addition to the voltage reducing resistor. The capacitor will cause a phase shift resulting in the ZCD output switch in advance of the actual zero-crossing event. The phase shift will be the same for both rising and falling zero crossings, which can be compensated for by either delaying the CPU response to the ZCD switch by a timer or other means, or selecting a capacitor value large enough that the phase shift is negligible.

To determine the series resistor and capacitor values for this configuration, start by computing the impedance,  $Z$ , to obtain a peak current of 300  $\mu\text{A}$ . Next, arbitrarily select a suitably large non-polar capacitor and compute its reactance,  $X_C$ , at the external voltage source frequency. Finally, compute the series resistor, capacitor peak voltage, and phase shift by the formulas shown in [Equation 20-2](#).

## EQUATION 20-2: R-C CALCULATIONS

$V_{peak}$  = external voltage source peak voltage  
 $f$  = external voltage source frequency  
 $C$  = series capacitor  
 $R$  = series resistor  
 $V_C$  = Peak capacitor voltage  
 $\phi$  = Capacitor induced zero crossing phase advance in radians  
 $T_\phi$  = Time ZC event occurs before actual zero crossing

$$Z = \frac{V_{PEAK}}{3 \times 10^{-4}}$$

$$X_C = \frac{1}{(2\pi fC)}$$

$$R = \sqrt{Z^2 - X_C^2}$$

$$V_C = X_C(3 \times 10^{-4})$$

$$\phi = \tan^{-1}\left(\frac{X_C}{R}\right)$$

$$T_\phi = \frac{\phi}{(2\pi f)}$$

## EQUATION 20-3: R-C CALCULATIONS EXAMPLE

$$V_{rms} = 120$$

$$V_{peak} = V_{rms} \cdot \sqrt{2} = 169.7$$

$$f = 60 \text{ Hz}$$

$$C = 0.1 \mu\text{f}$$

$$Z = \frac{V_{peak}}{3 \times 10^{-4}} = \frac{169.7}{3 \times 10^{-4}} = 565.7 \text{ kOhms}$$

$$X_C = \frac{1}{(2\pi fC)} = \frac{1}{(2\pi \cdot 60 \cdot 1 \cdot 10^{-7})} = 26.53 \text{ kOhms}$$

$$R = \sqrt{Z^2 - X_C^2} = 565.1 \text{ k Ohms (computed)}$$

$$R = 560 \text{ kOhms (used)}$$

$$Z_R = \sqrt{(R^2 + X_C^2)} = 560.6 \text{ kOhm (using actual resistor)}$$

$$I_{peak} = \frac{V_{peak}}{Z_R} = 302.7 \cdot 10^{-6}$$

$$V_C = X_C \cdot I_{peak} = 8.0 \text{ V}$$

$$\phi = \tan^{-1}\left(\frac{X_C}{R}\right) = 0.047 \text{ radians}$$

$$T_\phi = \frac{\phi}{(2\pi f)} = 125.6 \mu\text{s}$$

## 20.5.2 CORRECTION BY OFFSET CURRENT

When the waveform is varying relative to Vss then the zero cross is detected too early as the waveform falls and too late as the waveform rises. When the waveform is varying relative to VDD then the zero cross is detected too late as the waveform rises and too early as the waveform falls. The actual offset time can be determined for sinusoidal waveforms with the corresponding equations shown in [Equation 20-4](#).

### EQUATION 20-4: ZCD EVENT OFFSET

When External Voltage Source is relative to Vss:

$$T_{offset} = \frac{\text{asin}\left(\frac{Z_{cpinv}}{V_{peak}}\right)}{2\pi \bullet \text{Freq}}$$

When External Voltage Source is relative to VDD:

$$T_{offset} = \frac{\text{asin}\left(\frac{V_{DD}-Z_{cpinv}}{V_{peak}}\right)}{2\pi \bullet \text{Freq}}$$

This offset time can be compensated for by adding a pull-up or pull-down biasing resistor to the ZCD pin. A pull-up resistor is used when the external voltage source is varying relative to Vss. A pull-down resistor is used when the voltage is varying relative to VDD. The resistor adds a bias to the ZCD pin so that the target external voltage source must go to zero to pull the pin voltage to the ZCPINV switching voltage. The pull-up or pull-down value can be determined with the equations shown in [Equation 20-5](#).

### EQUATION 20-5: ZCD PULL-UP/DOWN

When External Signal is relative to Vss:

$$R_{pullup} = \frac{R_{series}(V_{pullup} - Z_{cpinv})}{Z_{cpinv}}$$

When External Signal is relative to VDD:

$$R_{pulldown} = \frac{R_{series}(Z_{cpinv})}{(V_{DD} - Z_{cpinv})}$$

## 20.6 Handling VPEAK variations

If the peak amplitude of the external voltage is expected to vary then the series resistor must be selected to keep the ZCD current source and sink below the design maximum range of  $\pm 600 \mu\text{A}$  for the maximum expected voltage and high enough to be detected accurately at the minimum peak voltage. A general rule of thumb is that the maximum peak voltage can be no more than six times the minimum peak voltage. To ensure that the maximum current does not exceed  $\pm 600 \mu\text{A}$  and the minimum is at least  $\pm 100 \mu\text{A}$ , compute the series resistance as shown in [Equation 20-6](#). The compensating pull-up for this series resistance can be determined with [Equation 20-5](#) because the pull-up value is independent from the peak voltage.

### EQUATION 20-6: SERIES R FOR V RANGE

$$R_{series} = \frac{V_{maxpeak} + V_{minpeak}}{7 \times 10^{-4}}$$

## 20.7 Operation During Sleep

The ZCD current sources and interrupts are unaffected by Sleep.

## 20.8 Effects of a Reset

The ZCD circuit can be configured to default to the active or inactive state on Power-on Reset (POR). When the ZCD Configuration bit is cleared, the ZCD circuit will be active at POR. When the ZCD Configuration bit is set, the EN bit of the ZCDxCON register must be set to enable the ZCD module.

## 20.9 Register Definitions: ZCD Control

Long bit name prefixes for the Zero-Cross Detect peripheral are shown in Table 20-1. Refer to Section 1.1.2.2 “Long Bit Names” for more information

**TABLE 20-1: BIT NAME PREFIXES**

Peripheral	Bit Name Prefix
ZCD1	ZCD1

**REGISTER 20-1: ZCDxCON: ZERO-CROSS DETECTION x CONTROL REGISTER**

R/W-0/0	U-0	R-x/x	R/W-0/0	U-0	U-0	R/W-0/0	R/W-0/0
EN <sup>(1)</sup>	—	OUT	POL	—	—	INTP	INTN
bit 7							bit 0

**Legend:**

R = Readable bit	W = Writable bit	U = Unimplemented bit, read as '0'
u = Bit is unchanged	x = Bit is unknown	-n/n = Value at POR and BOR/Value at all other Resets
'1' = Bit is set	'0' = Bit is cleared	q = value depends on configuration bits

- bit 7      **EN:** Zero-Cross Detection Enable bit<sup>(1)</sup>  
 1 = Zero-Cross Detect is enabled; ZCD pin is forced to output to source and sink current  
 0 = Zero-Cross Detect is disabled; ZCD pin operates according to PPS and TRISx controls
- bit 6      **Unimplemented:** Read as '0'
- bit 5      **OUT:** Zero-Cross Detection Logic Level bit  
POL bit = 0:  
 1 = ZCD pin is sinking current  
 0 = ZCD pin is sourcing current  
POL bit = 1:  
 1 = ZCD pin is sourcing current  
 0 = ZCD pin is sinking current
- bit 4      **POL:** Zero-Cross Detection Logic Output Polarity bit  
 1 = ZCD logic output is inverted  
 0 = ZCD logic output is not inverted
- bit 3-2    **Unimplemented:** Read as '0'
- bit 1      **INTP:** Zero-Cross Positive Edge Interrupt Enable bit  
 1 = ZCDIF bit is set on low-to-high OUT transition  
 0 = ZCDIF bit is unaffected by low-to-high OUT transition
- bit 0      **INTN:** Zero-Cross Negative Edge Interrupt Enable bit  
 1 = ZCDIF bit is set on high-to-low OUT transition  
 0 = ZCDIF bit is unaffected by high-to-low OUT transition

**Note 1:** The EN bit has no effect when the  $\overline{\text{ZCD}}$  Configuration bit is cleared.

# PIC16(L)F1764/5/8/9

**TABLE 20-2: SUMMARY OF REGISTERS ASSOCIATED WITH THE ZCD MODULE**

Name	Bit 7	Bit 6	Bit 5	Bit 4	Bit 3	Bit 2	Bit 1	Bit 0	Register on page
PIE3	PWM6IE <sup>(1)</sup>	PWM5IE	COG1IE	ZCDIE	COG2IE <sup>(1)</sup>	CLC3IE	CLC2IE	CLC1IE	104
PIR3	PWM6IF <sup>(1)</sup>	PWM5IF	COG1IF	ZCDIF	COG2IF <sup>(1)</sup>	CLC3IF	CLC2IF	CLC1IF	108
ZCD1CON	EN	—	OUT	POL	—	—	INTP	INTN	212

**Legend:** — = unimplemented, read as '0'. Shaded cells are unused by the ZCD module.

**Note 1:** PIC16(L)F1768/9 only.

**TABLE 20-3: SUMMARY OF CONFIGURATION WORD WITH THE ZCD MODULE**

Name	Bits	Bit -/7	Bit -/6	Bit 13/5	Bit 12/4	Bit 11/3	Bit 10/2	Bit 9/1	Bit 8/0	Register on Page
CONFIG2	13:8	—	—	LVP	$\overline{\text{DEBUG}}$	$\overline{\text{LPBOR}}$	BORV	STVREN	PLLEN	65
	7:0	$\overline{\text{ZCD}}$	—	—	—	—	PPS1WAY	WRT<1:0>		

**Legend:** — = unimplemented location, read as '0'. Shaded cells are not used by the ZCD module.

## 21.0 TIMER0 MODULE

The Timer0 module is an 8-bit timer/counter with the following features:

- 8-bit timer/counter register (TMR0)
- 8-bit prescaler (independent of Watchdog Timer)
- Programmable internal or external clock source
- Programmable external clock edge selection
- Interrupt-on-overflow
- TMR0 can be used to gate Timer1

Figure 21-1 is a block diagram of the Timer0 module.

### 21.1 Timer0 Operation

The Timer0 module can be used as either an 8-bit timer or an 8-bit counter.

#### 21.1.1 8-BIT TIMER MODE

The Timer0 module will increment every instruction cycle if used without a prescaler. 8-Bit Timer mode is selected by clearing the TMR0CS bit of the OPTION\_REG register.

When TMR0 is written, the increment is inhibited for two instruction cycles immediately following the write.

**Note:** The value written to the TMR0 register can be adjusted, in order to account for the two instruction cycle delay when TMR0 is written.

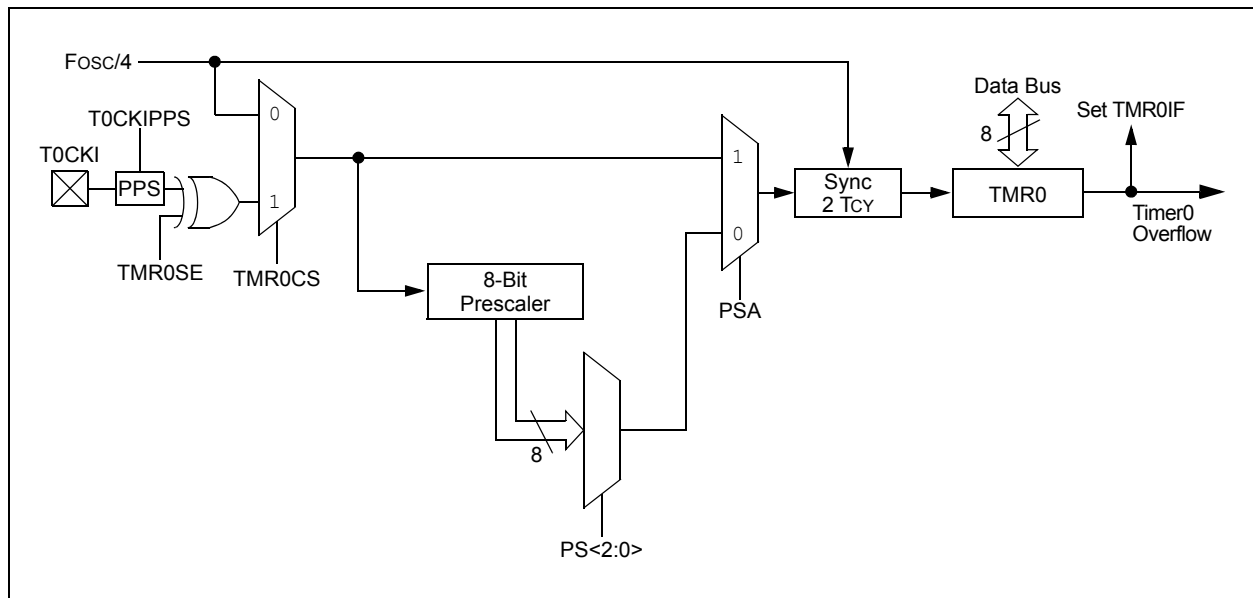
#### 21.1.2 8-BIT COUNTER MODE

In 8-Bit Counter mode, the Timer0 module will increment on every rising or falling edge of the T0CKI pin.

8-Bit Counter mode using the T0CKI pin is selected by setting the TMR0CS bit in the OPTION\_REG register to '1'.

The rising or falling transition of the incrementing edge for either input source is determined by the TMR0SE bit in the OPTION\_REG register.

**FIGURE 21-1: BLOCK DIAGRAM OF TIMER0**



## 21.1.3 SOFTWARE PROGRAMMABLE PRESCALER

A software programmable prescaler is available for exclusive use with Timer0. The prescaler is enabled by clearing the PSA bit of the OPTION\_REG register.

**Note:** The Watchdog Timer (WDT) uses its own independent prescaler.

There are eight prescaler options for the Timer0 module, ranging from 1:2 to 1:256. The prescale values are selectable via the PS<2:0> bits of the OPTION\_REG register. In order to have a 1:1 prescaler value for the Timer0 module, the prescaler must be disabled by setting the PSA bit of the OPTION\_REG register.

The prescaler is not readable or writable. All instructions writing to the TMR0 register will clear the prescaler.

## 21.1.4 TIMER0 INTERRUPT

Timer0 will generate an interrupt when the TMR0 register overflows from FFh to 00h. The TMR0IF interrupt flag bit of the INTCON register is set every time the TMR0 register overflows, regardless of whether or not the Timer0 interrupt is enabled. The TMR0IF bit can only be cleared in software. The Timer0 interrupt enable is the TMR0IE bit of the INTCON register.

**Note:** The Timer0 interrupt cannot wake the processor from Sleep since the timer is frozen during Sleep.

## 21.1.5 8-BIT COUNTER MODE SYNCHRONIZATION

When in 8-Bit Counter mode, the incrementing edge on the T0CKI pin must be synchronized to the instruction clock. Synchronization can be accomplished by sampling the prescaler output on the Q2 and Q4 cycles of the instruction clock. The high and low periods of the external clocking source must meet the timing requirements as shown in [Table 36-12: Timer0 and Timer1 External Clock Requirements](#).

## 21.1.6 OPERATION DURING SLEEP

Timer0 cannot operate while the processor is in Sleep mode. The contents of the TMR0 register will remain unchanged while the processor is in Sleep mode.

## 21.2 Register Definitions: Option Register

### REGISTER 21-1: OPTION\_REG: OPTION REGISTER

R/W-1/1	R/W-1/1	R/W-1/1	R/W-1/1	R/W-1/1	R/W-1/1	R/W-1/1	R/W-1/1
$\overline{\text{WPUEN}}$	INTEDG	TMR0CS	TMR0SE	PSA	PS<2:0>		
bit 7							bit 0

#### Legend:

R = Readable bit	W = Writable bit	
u = Bit is unchanged	x = Bit is unknown	U = Unimplemented bit, read as '0'
'1' = Bit is set	'0' = Bit is cleared	-n/n = Value at POR and BOR/Value at all other Resets

- bit 7  **$\overline{\text{WPUEN}}$** : Weak Pull-Up Enable bit  
 1 = All weak pull-ups are disabled (except  $\overline{\text{MCLR}}$ , if it is enabled)  
 0 = Weak pull-ups are enabled by individual  $\text{WPUx}$  latch values
- bit 6 **INTEDG**: Interrupt Edge Select bit  
 1 = Interrupt on rising edge of INT pin  
 0 = Interrupt on falling edge of INT pin
- bit 5 **TMR0CS**: Timer0 Clock Source Select bit  
 1 = Transition on T0CKI pin  
 0 = Internal instruction cycle clock ( $F_{\text{OSC}}/4$ )
- bit 4 **TMR0SE**: Timer0 Source Edge Select bit  
 1 = Increment on high-to-low transition on T0CKI pin  
 0 = Increment on low-to-high transition on T0CKI pin
- bit 3 **PSA**: Prescaler Assignment bit  
 1 = Prescaler is not assigned to the Timer0 module  
 0 = Prescaler is assigned to the Timer0 module
- bit 2-0 **PS<2:0>**: Prescaler Rate Select bits

Bit Value	Timer0 Rate
000	1 : 2
001	1 : 4
010	1 : 8
011	1 : 16
100	1 : 32
101	1 : 64
110	1 : 128
111	1 : 256

**TABLE 21-1: SUMMARY OF REGISTERS ASSOCIATED WITH TIMER0**

Name	Bit 7	Bit 6	Bit 5	Bit 4	Bit 3	Bit 2	Bit 1	Bit 0	Register on Page
INTCON	GIE	PEIE	TMR0IE	INTE	IOCFIE	TMR0IF	INTF	IOCFIF	101
OPTION_REG	$\overline{\text{WPUEN}}$	INTEDG	TMR0CS	TMR0SE	PSA	PS<2:0>			216
TMR0	Timer0 Module Register								214*
TRISA	—	—	TRISA<5:4>		— <sup>(1)</sup>	TRISA2	TRISA<1:0>		138

**Legend:** — = Unimplemented location, read as '0'. Shaded cells are not used by the Timer0 module.

\* Page provides register information.

**Note 1:** Unimplemented, read as '1'.



## 22.0 TIMER1/3/5 MODULE WITH GATE CONTROL

The Timer1 module is a 16-bit timer/counter with the following features:

- 16-Bit Timer/Counter register pair (TMR1H:TMR1L)
- Programmable internal or external clock source
- 2-bit prescaler
- Dedicated 32 kHz oscillator circuit
- Optionally synchronized comparator out
- Multiple Timer1 gate (count enable) sources
- Interrupt-on-overflow
- Wake-up on overflow (external clock, Asynchronous mode only)
- Time base for the capture/compare function
- Auto-conversion trigger (with CCP)

- Selectable gate source polarity
- Gate Toggle mode
- Gate Single-Pulse mode
- Gate value status
- Gate event interrupt

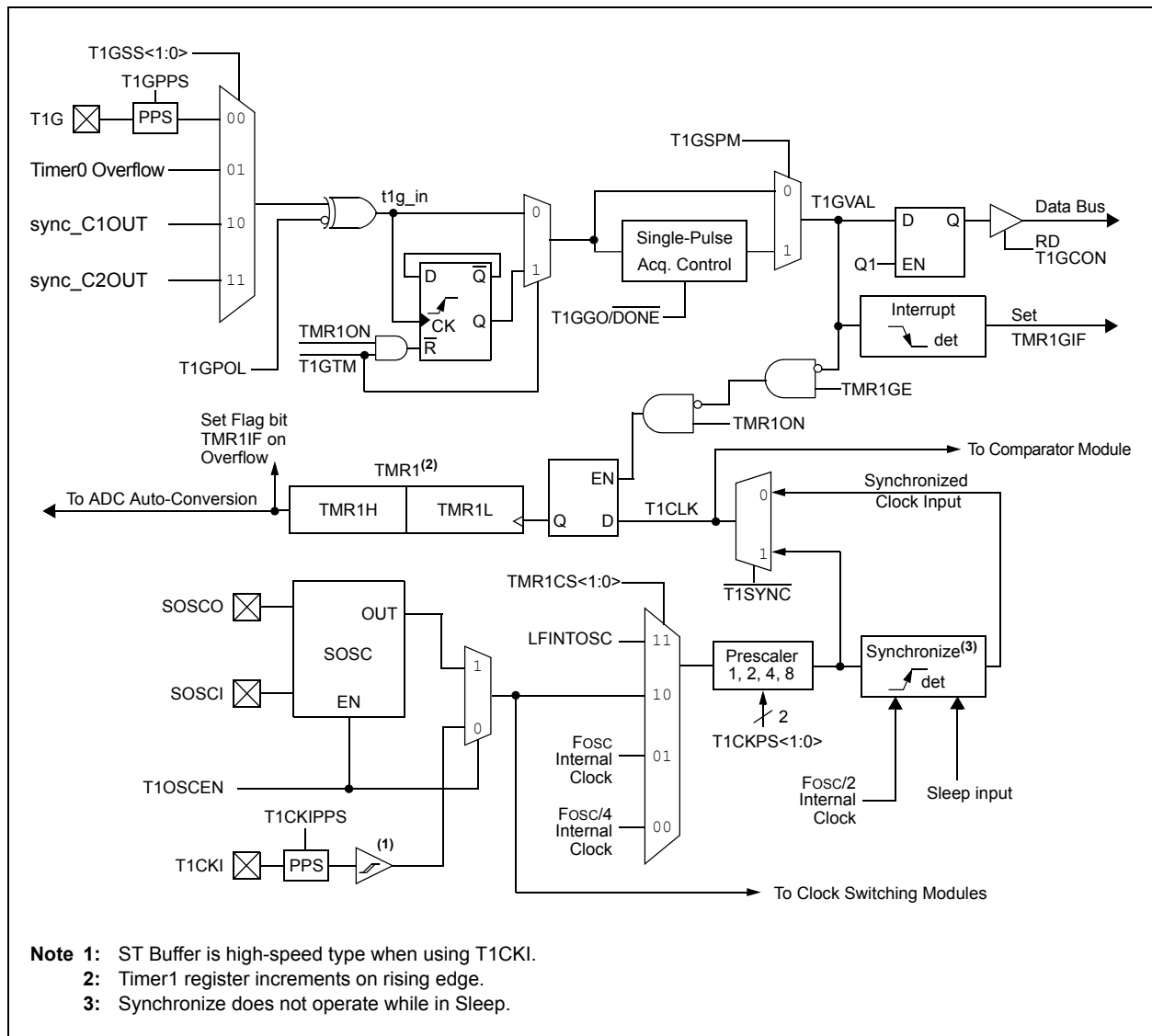
Figure 22-1 is a block diagram of the Timer1 module.

This device has three instances of Timer1 type modules. They include:

- Timer1
- Timer3
- Timer5

All references to Timer1 and Timer1 gate apply equally to Timer3 and Timer5.

**FIGURE 22-1: TIMER1 BLOCK DIAGRAM**



## 22.1 Timer1 Operation

The Timer1 module is a 16-bit incrementing counter which is accessed through the TMR1H:TMR1L register pair. Writes to TMR1H or TMR1L directly update the counter.

When used with an internal clock source, the module is a timer and increments on every instruction cycle. When used with an external clock source, the module can be used as either a timer or counter and increments on every selected edge of the external source.

Timer1 is enabled by configuring the ON and GE bits in the T1CON and T1GCON registers, respectively. Table 22-1 displays the Timer1 enable selections.

**TABLE 22-1: TIMER1 ENABLE SELECTIONS**

TMR1ON	TMR1GE	Timer1 Operation
0	0	Off
0	1	Off
1	0	Always On
1	1	Count Enabled

## 22.2 Clock Source Selection

The CS<1:0> and OSCEN bits of the T1CON register are used to select the clock source for Timer1. Table 22-2 displays the clock source selections.

### 22.2.1 INTERNAL CLOCK SOURCE

When the internal clock source is selected, the TMR1H:TMR1L register pair will increment on multiples of FOSC, as determined by the Timer1 prescaler.

When the Fosc internal clock source is selected, the Timer1 register value will increment by four counts every instruction clock cycle. Due to this condition, a 2 LSB error in resolution will occur when reading the Timer1 value. To utilize the full resolution of Timer1, an asynchronous input signal must be used to gate the Timer1 clock input.

The following asynchronous sources may be used:

- Asynchronous event on the T1G pin to Timer1 gate
- C1 or C2 comparator input to Timer1 gate

### 22.2.2 EXTERNAL CLOCK SOURCE

When the external clock source is selected, the Timer1 module may work as a timer or a counter.

When enabled to count, Timer1 is incremented on the rising edge of the external clock input T1CKI, which can be synchronized to the microcontroller system clock or can run asynchronously.

When used as a timer with a clock oscillator, an external 32.768 kHz crystal can be used in conjunction with the dedicated internal oscillator circuit.

**Note:** In Counter mode, a falling edge must be registered by the counter prior to the first incrementing rising edge after any one or more of the following conditions:

- Timer1 enabled after POR
- Write to TMR1H or TMR1L
- Timer1 is disabled
- Timer1 is disabled (TMR1ON = 0) when T1CKI is high then Timer1 is enabled (TMR1ON = 1) when T1CKI is low

**TABLE 22-2: CLOCK SOURCE SELECTIONS**

TMR1CS<1:0>	T1OSCEN	Clock Source
11	x	LFINTOSC
10	0	External Clocking on T1CKI Pin
01	x	System Clock (FOSC)
00	x	Instruction Clock (FOSC/4)

## 22.3 Timer1 Prescaler

Timer1 has four prescaler options, allowing 1, 2, 4 or 8 divisions of the clock input. The CKPS<1:0> bits of the T1CON register control the prescale counter. The prescale counter is not directly readable or writable; however, the prescaler counter is cleared upon a write to TMR1H or TMR1L.

## 22.4 Timer1 (Secondary) Oscillator

A dedicated low-power 32.768 kHz oscillator circuit is built in between pins, SOSCI (input) and SOSCO (amplifier output). This internal circuit is to be used in conjunction with an external 32.768 kHz crystal.

The oscillator circuit is enabled by setting the OSCEN bit of the T1CON register. The oscillator will continue to run during Sleep.

**Note:** The oscillator requires a start-up and stabilization time before use. Thus, OSCEN should be set and a suitable delay observed prior to using Timer1. A suitable delay similar to the OST delay can be implemented in software by clearing the TMR1IF bit then presetting the TMR1H:TMR1L register pair to FC00h. The TMR1IF flag will be set when 1024 clock cycles have elapsed, thereby indicating that the oscillator is running and reasonably stable.

## 22.5 Timer1 Operation in Asynchronous Counter Mode

If the control bit, SYNC of the T1CON register, is set, the external clock input is not synchronized. The timer increments asynchronously to the internal phase clocks. If the external clock source is selected then the timer will continue to run during Sleep and can generate an interrupt-on-overflow, which will wake-up the processor. However, special precautions in software are needed to read/write the timer (see [Section 22.5.1 “Reading and Writing Timer1 in Asynchronous Counter Mode”](#)).

**Note:** When switching from synchronous to asynchronous operation, it is possible to skip an increment. When switching from asynchronous to synchronous operation, it is possible to produce an additional increment.

### 22.5.1 READING AND WRITING TIMER1 IN ASYNCHRONOUS COUNTER MODE

Reading TMR1H or TMR1L while the timer is running from an external asynchronous clock will ensure a valid read (taken care of in hardware). However, the user should keep in mind that reading the 16-bit timer in two 8-bit values itself, poses certain problems, since the timer may overflow between the reads.

For writes, it is recommended that the user simply stop the timer and write the desired values. A write contention may occur by writing to the timer registers, while the register is incrementing. This may produce an unpredictable value in the TMR1H:TMR1L register pair.

## 22.6 Timer1 Gate

Timer1 can be configured to count freely or the count can be enabled and disabled using Timer1 gate circuitry. This is also referred to as Timer1 Gate Enable.

Timer1 gate can also be driven by multiple selectable sources.

### 22.6.1 TIMER1 GATE ENABLE

The Timer1 Gate Enable mode is enabled by setting the GE bit of the T1GCON register. The polarity of the Timer1 Gate Enable mode is configured using the GPOL bit of the T1GCON register.

When Timer1 Gate Enable mode is enabled, Timer1 will increment on the rising edge of the Timer1 clock source. When Timer1 Gate Enable mode is disabled, no incrementing will occur and Timer1 will hold the current count. See [Figure 22-3](#) for timing details.

**TABLE 22-3: TIMER1 GATE ENABLE SELECTIONS**

T1CLK	T1GPOL	T1G	Timer1 Operation
↑	0	0	Counts
↑	0	1	Holds Count
↑	1	0	Holds Count
↑	1	1	Counts

## 22.6.2 TIMER1 GATE SOURCE SELECTION

Timer1 gate source selections are shown in [Table 22-4](#). Source selection is controlled by the T1GSS bits of the T1GCON register. The polarity for each available source is also selectable. Polarity selection is controlled by the T1GPOL bit of the T1GCON register.

**TABLE 22-4: TIMER1 GATE SOURCES**

T1GSS<1:0>	Timer1 Gate Source
00	Timer1 Gate Pin
01	Overflow of Timer0 (TMR0 increments from FFh to 00h)
10	Comparator 1 Output sync_C1OUT (optionally Timer1 synchronized output)
11	Comparator 2 Output sync_C2OUT (optionally Timer1 synchronized output)

### 22.6.2.1 T1G Pin Gate Operation

The T1G pin is one source for Timer1 gate control. It can be used to supply an external source to the Timer1 gate circuitry.

### 22.6.2.2 Timer0 Overflow Gate Operation

When Timer0 increments from FFh to 00h, a low-to-high pulse will automatically be generated and internally supplied to the Timer1 gate circuitry.

### 22.6.2.3 Comparator C1 Gate Operation

The output resulting from a Comparator 1 operation can be selected as a source for Timer1 gate control. The Comparator 1 output (sync\_C1OUT) can be synchronized to the Timer1 clock or left asynchronous. For more information, see [Section 19.4.1 “Comparator Output Synchronization”](#).

### 22.6.2.4 Comparator C2 Gate Operation

The output resulting from a Comparator 2 operation can be selected as a source for Timer1 gate control. The Comparator 2 output (sync\_C2OUT) can be synchronized to the Timer1 clock or left asynchronous. For more information, see [Section 19.4.1 “Comparator Output Synchronization”](#).

## 22.6.3 TIMER1 GATE TOGGLE MODE

When Timer1 Gate Toggle mode is enabled, it is possible to measure the full-cycle length of a Timer1 gate signal, as opposed to the duration of a single level pulse.

The Timer1 gate source is routed through a flip-flop that changes state on every incrementing edge of the signal. See [Figure 22-4](#) for timing details.

Timer1 Gate Toggle mode is enabled by setting the T1GTM bit of the T1GCON register. When the T1GTM bit is cleared, the flip-flop is cleared and held clear. This is necessary in order to control which edge is measured.

**Note:** Enabling Toggle mode at the same time as changing the gate polarity may result in indeterminate operation.

## 22.6.4 TIMER1 GATE SINGLE-PULSE MODE

When Timer1 Gate Single-Pulse mode is enabled, it is possible to capture a single-pulse gate event. Timer1 Gate Single-Pulse mode is first enabled by setting the T1GSPM bit in the T1GCON register. Next, the T1GGO/DONE bit in the T1GCON register must be set. The Timer1 will be fully enabled on the next incrementing edge. On the next trailing edge of the pulse, the T1GGO/DONE bit will automatically be cleared. No other gate events will be allowed to increment Timer1 until the T1GGO/DONE bit is once again set in software. See [Figure 22-5](#) for timing details.

If the Single-Pulse Gate mode is disabled by clearing the T1GSPM bit in the T1GCON register, the T1GGO/DONE bit should also be cleared.

Enabling the Toggle mode and the Single-Pulse mode simultaneously will permit both sections to work together. This allows the cycle times on the Timer1 gate source to be measured. See [Figure 22-6](#) for timing details.

## 22.6.5 TIMER1 GATE VALUE STATUS

When Timer1 gate value status is utilized, it is possible to read the most current level of the gate control value. The value is stored in the T1GVAL bit in the T1GCON register. The T1GVAL bit is valid even when the Timer1 gate is not enabled (TMR1GE bit is cleared).

## 22.6.6 TIMER1 GATE EVENT INTERRUPT

When Timer1 Gate Event Interrupt is enabled, it is possible to generate an interrupt upon the completion of a gate event. When the falling edge of T1GVAL occurs, the TMR1GIF flag bit in the PIR1 register will be set. If the TMR1GIE bit in the PIE1 register is set, then an interrupt will be recognized.

The TMR1GIF flag bit operates even when the Timer1 gate is not enabled (TMR1GE bit is cleared).

## 22.7 Timer1 Interrupt

The Timer1 register pair (TMR1H:TMR1L) increments to FFFFh and rolls over to 0000h. When Timer1 rolls over, the Timer1 interrupt flag bit of the PIR1 register is set. To enable the interrupt-on-rollover, you must set these bits:

- ON bit of the T1CON register
- TMR1IE bit of the PIE1 register
- PEIE bit of the INTCON register
- GIE bit of the INTCON register

The interrupt is cleared by clearing the TMR1IF bit in the Interrupt Service Routine.

**Note:** The TMR1H:TMR1L register pair and the TMR1IF bit should be cleared before enabling interrupts.

## 22.8 Timer1 Operation During Sleep

Timer1 can only operate during Sleep when setup in Asynchronous Counter mode. In this mode, an external crystal or clock source can be used to increment the counter. To set up the timer to wake the device:

- ON bit of the T1CON register must be set
- TMR1IE bit of the PIE1 register must be set
- PEIE bit of the INTCON register must be set
- SYNC bit of the T1CON register must be set
- CS<1:0> bits of the T1CON register must be configured
- OSCEN bit of the T1CON register must be configured

The device will wake-up on an overflow and execute the next instructions. If the GIE bit of the INTCON register is set, the device will call the Interrupt Service Routine.

The secondary oscillator will continue to operate in Sleep regardless of the SYNC bit setting.

## 22.9 CCP Capture/Compare Time Base

The CCP modules use the TMR1H:TMR1L register pair as the time base when operating in Capture or Compare mode.

In Capture mode, the value in the TMR1H:TMR1L register pair is copied into the CCPR1H:CCPR1L register pair on a configured event.

In Compare mode, an event is triggered when the value CCPR1H:CCPR1L register pair matches the value in the TMR1H:TMR1L register pair. This event can be an Auto-conversion Trigger.

For more information, see [Section 24.0 “Capture/Compare/PWM Modules”](#).

## 22.10 CCP Auto-Conversion Trigger

When any of the CCPs are configured to trigger an auto-conversion, the trigger will clear the TMR1H:TMR1L register pair. This auto-conversion does not cause a Timer1 interrupt. The CCP module may still be configured to generate a CCP interrupt.

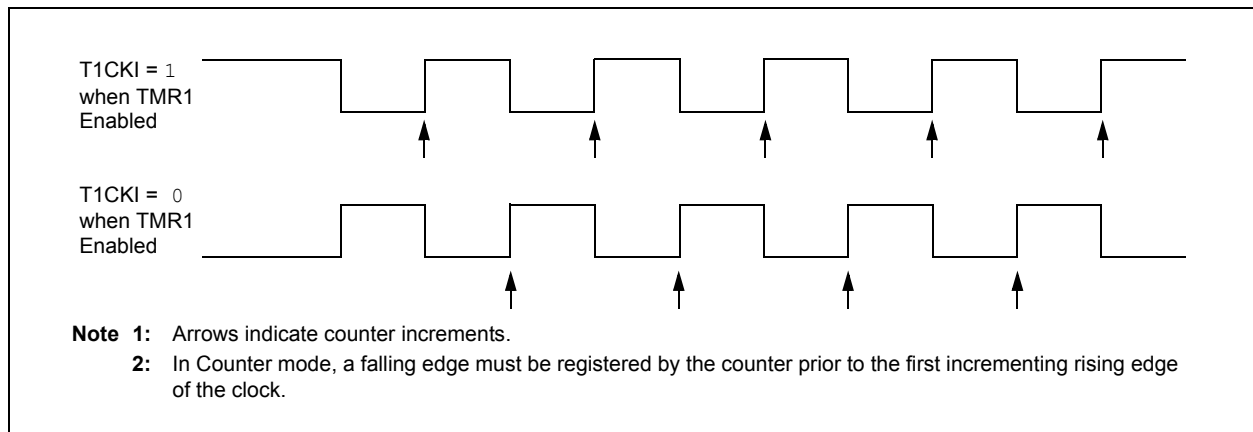
In this mode of operation, the CCPR1H:CCPR1L register pair becomes the period register for Timer1.

Timer1 should be synchronized and FOSC/4 should be selected as the clock source in order to utilize the Auto-conversion Trigger. Asynchronous operation of Timer1 can cause an Auto-conversion Trigger to be missed.

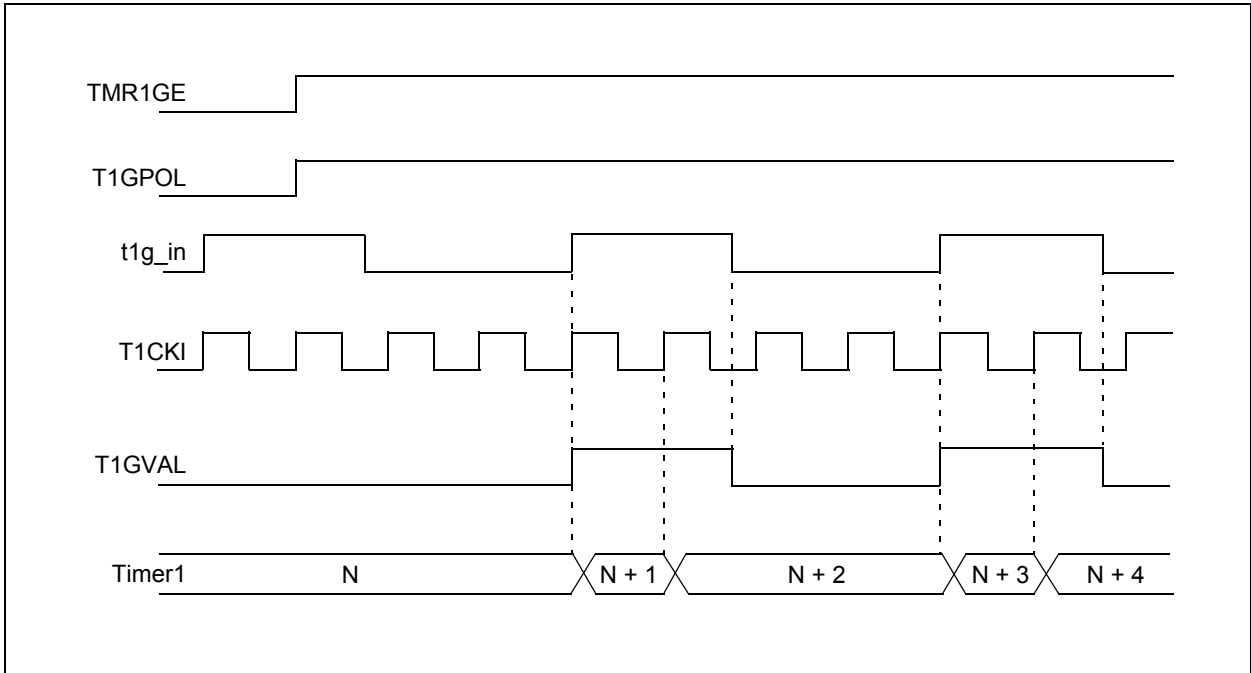
In the event that a write to TMR1H or TMR1L coincides with an Auto-conversion Trigger from the CCP, the write will take precedence.

For more information, see [Section 24.2.1 “Auto-Conversion Trigger”](#).

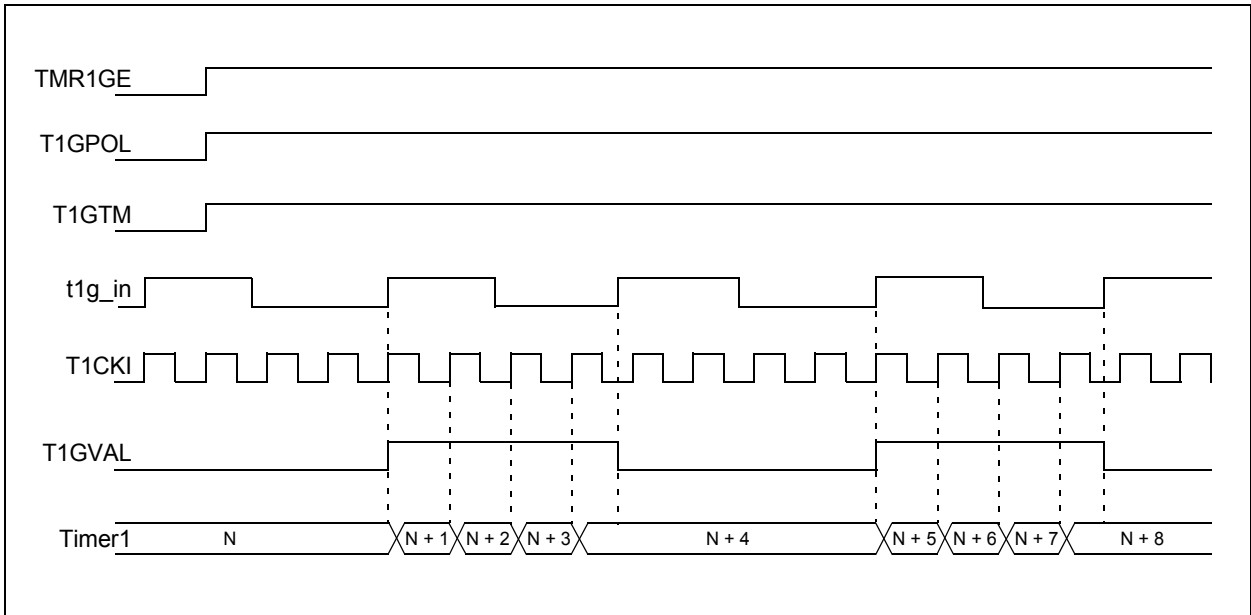
**FIGURE 22-2: TIMER1 INCREMENTING EDGE**



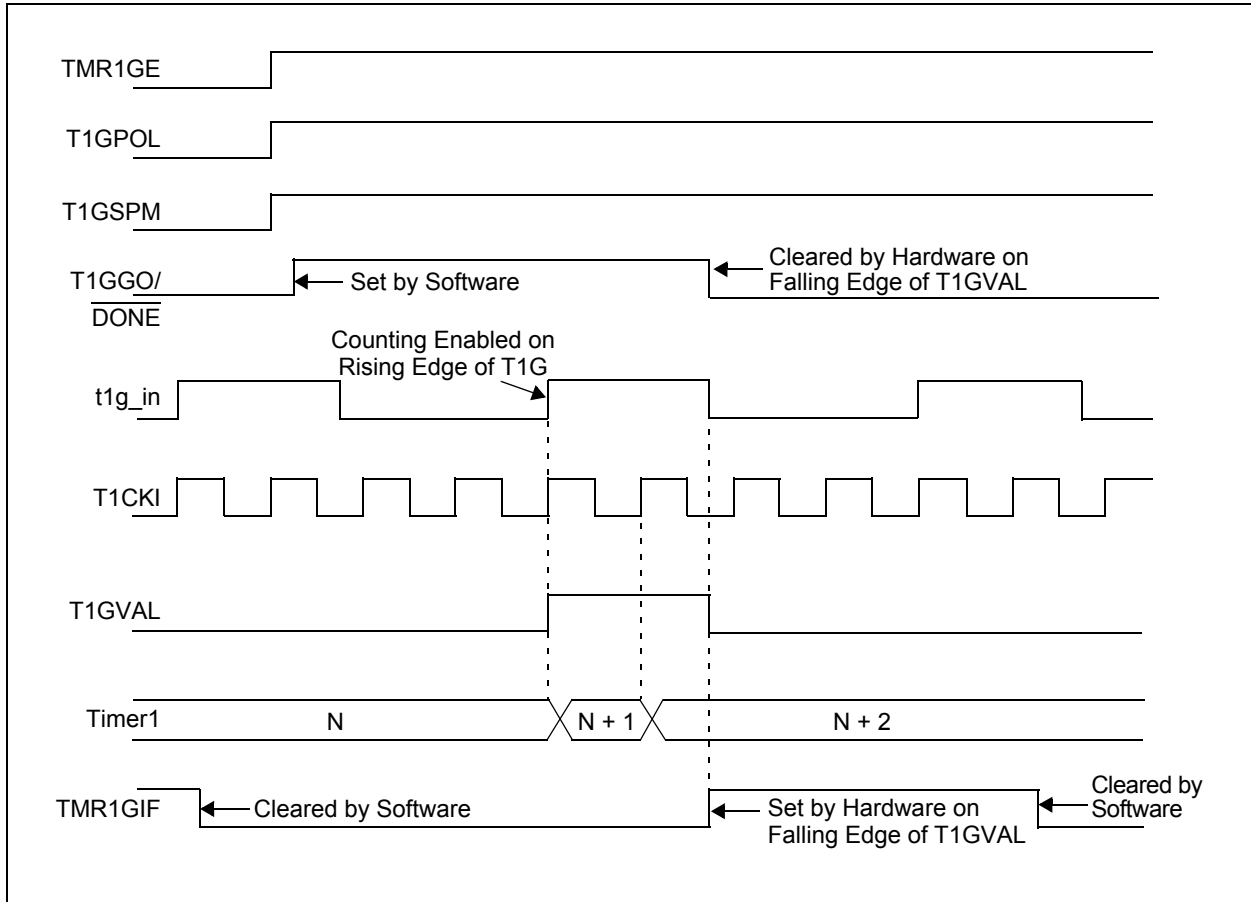
**FIGURE 22-3: TIMER1 GATE ENABLE MODE**



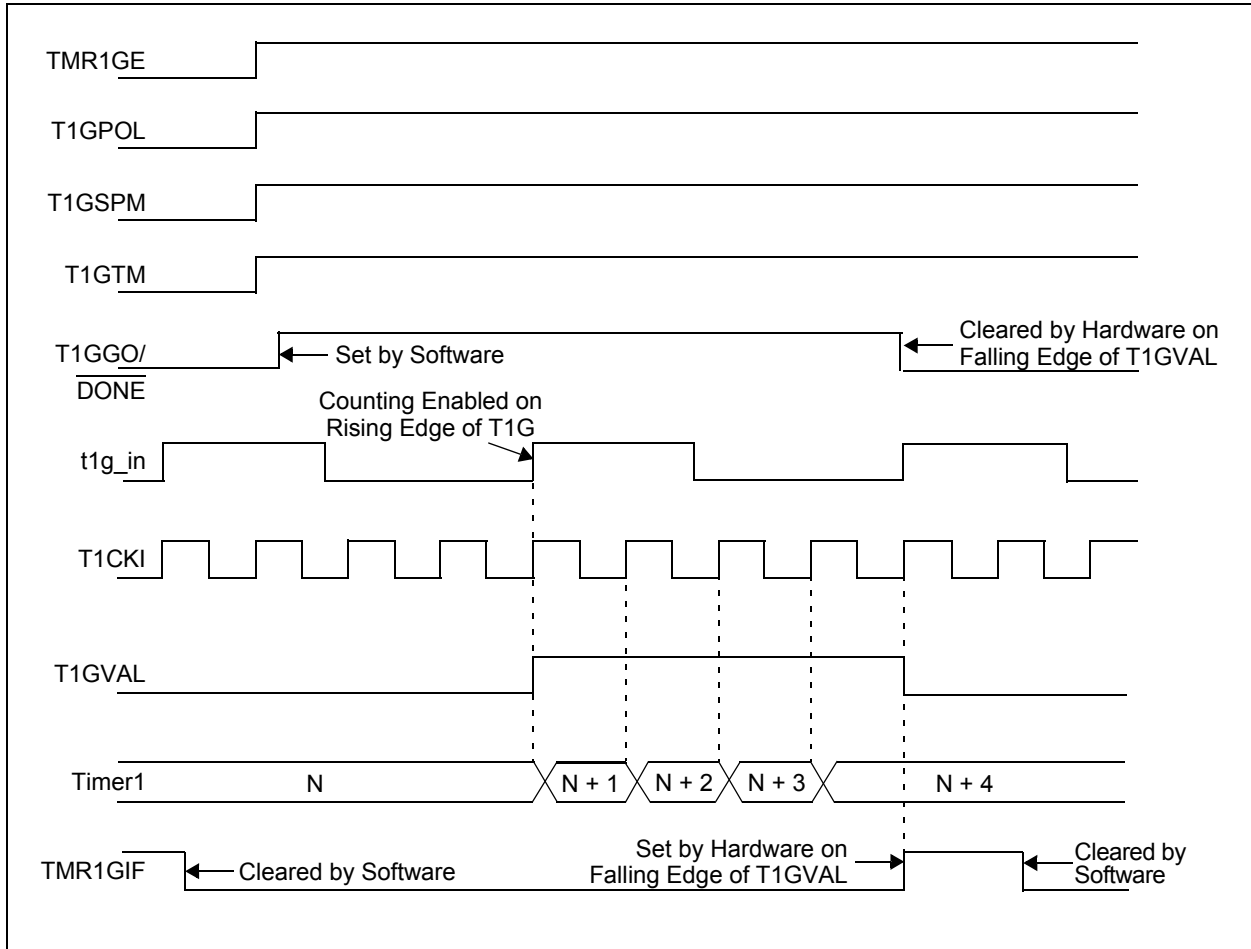
**FIGURE 22-4: TIMER1 GATE TOGGLE MODE**



**FIGURE 22-5: TIMER1 GATE SINGLE-PULSE MODE**



**FIGURE 22-6: TIMER1 GATE SINGLE-PULSE AND TOGGLE COMBINED MODE**





## 22.11 Register Definitions: Timer1 Control

Long bit name prefixes for the Timer1 peripherals are shown in Table 22-5. Refer to Section 1.1.2.2 “Long Bit Names” for more information.

**TABLE 22-5: BIT NAME PREFIXES**

Peripheral	Bit Name Prefix
Timer1	T1
Timer3	T3
Timer5	T5

### REGISTER 22-1: T1CON: TIMER1 CONTROL REGISTER

R/W-0/u	R/W-0/u	R/W-0/u	R/W-0/u	R/W-0/u	R/W-0/u	U-0	R/W-0/u
CS<1:0>		CKPS<1:0>		OSCEN <sup>(1)</sup>	$\overline{\text{SYNC}}$	—	ON
bit 7							bit 0

#### Legend:

R = Readable bit	W = Writable bit	
u = Bit is unchanged	x = Bit is unknown	U = Unimplemented bit, read as '0'
'1' = Bit is set	'0' = Bit is cleared	-n/n = Value at POR and BOR/Value at all other Resets

- bit 7-6     **CS<1:0>**: Timer1 Clock Source Select bits  
 11 = Reserved, do not use  
 10 = Timer1 clock source is a pin or oscillator:<sup>(1)</sup>  
     If T1OSCEN = 0:  
         External clock from T1CKI pin (on the rising edge).  
     If T1OSCEN = 1:  
         Crystal oscillator on SOSC1/SOSCO pins.  
 01 = Timer1 clock source is the system clock (Fosc)  
 00 = Timer1 clock source is the instruction clock (Fosc/4)
- bit 5-4     **CKPS<1:0>**: Timer1 Input Clock Prescale Select bits  
 11 = 1:8 Prescale value  
 10 = 1:4 Prescale value  
 01 = 1:2 Prescale value  
 00 = 1:1 Prescale value
- bit 3       **OSCEN**: LP Oscillator Enable Control bit<sup>(1)</sup>  
 1 = Dedicated secondary oscillator circuit is enabled  
 0 = Dedicated secondary oscillator circuit is disabled
- bit 2       **SYNC**: Timer1 Synchronization Control bit  
 1 = Does not synchronize asynchronous clock input  
 0 = Synchronizes asynchronous clock input with system clock (Fosc)
- bit 1       **Unimplemented**: Read as '0'
- bit 0       **ON**: Timer1 On bit  
 1 = Enables Timer1  
 0 = Stops Timer1 and clears Timer1 gate flip-flop

**Note 1:** Timer1 only. Reserved, do not use for Timer3 and Timer5.

## REGISTER 22-2: T1GCON: TIMER1 GATE CONTROL REGISTER

R/W-0/u	R/W-0/u	R/W-0/u	R/W-0/u	R/W/HC-0/u	R-x/x	R/W-0/u	R/W-0/u
GE	GPOL	GTM	GSPM	<u>GGO/</u> <u>DONE</u>	GVAL	GSS<1:0>	
bit 7						bit 0	

### Legend:

R = Readable bit	W = Writable bit	U = Unimplemented bit, read as '0'
u = Bit is unchanged	x = Bit is unknown	-n/n = Value at POR and BOR/Value at all other Resets
'1' = Bit is set	'0' = Bit is cleared	HC = Hardware Clearable bit

bit 7 **GE:** Timer1 Gate Enable bit

If TMR1ON = 0:

This bit is ignored.

If TMR1ON = 1:

1 = Timer1 counting is controlled by the Timer1 gate function

0 = Timer1 counts regardless of Timer1 gate function

bit 6 **GPOL:** Timer1 Gate Polarity bit

1 = Timer1 gate is active-high (Timer1 counts when gate is high)

0 = Timer1 gate is active-low (Timer1 counts when gate is low)

bit 5 **GTM:** Timer1 Gate Toggle Mode bit

1 = Timer1 Gate Toggle mode is enabled

0 = Timer1 Gate Toggle mode is disabled and toggle flip-flop is cleared

Timer1 gate flip-flop toggles on every rising edge.

bit 4 **GSPM:** Timer1 Gate Single-Pulse Mode bit

1 = Timer1 Gate Single-Pulse mode is enabled and is controlling Timer1 gate

0 = Timer1 Gate Single-Pulse mode is disabled

bit 3 **GGO/DONE:** Timer1 Gate Single-Pulse Acquisition Status bit

1 = Timer1 gate single-pulse acquisition is ready, waiting for an edge

0 = Timer1 gate single-pulse acquisition has completed or has not been started

bit 2 **GVAL:** Timer1 Gate Value Status bit

Indicates the current state of the Timer1 gate that could be provided to TMR1H:TMR1L. Unaffected by Timer1 Gate Enable bit (TMR1GE).

bit 1-0 **GSS<1:0>:** Timer1 Gate Source Select bits

11 = Comparator 2 optionally synchronized output (sync\_C2OUT)

10 = Comparator 1 optionally synchronized output (sync\_C1OUT)

01 = Timer0 overflow output

00 = Timer1 gate pin

# PIC16(L)F1764/5/8/9

**TABLE 22-6: SUMMARY OF REGISTERS ASSOCIATED WITH TIMER1**

Name	Bit 7	Bit 6	Bit 5	Bit 4	Bit 3	Bit 2	Bit 1	Bit 0	Register on Page
ANSELA	—	—	—	ANSA4	—	ANSA<2:0>			139
CCPxCON	EN	OE	OUT	FMT	MODE<3:0>				258
INTCON	GIE	PEIE	TMR0IE	INTE	IOCF	TMR0IF	INTF	IOCF	101
PIE1	TMR1GIE	ADIE	RCIE	TXIE	SSP1IE	CCP1IE	TMR2IE	TMR1IE	102
PIE4	—	—	TMR5GIE	TMR5IE	TMR3GIE	TMR3IE	TMR6IE	TRM4IE	105
PIR1	TMR1GIF	ADIF	RCIF	TXIF	SSP1IF	CCP1IF	TMR2IF	TMR1IF	106
PIR4	—	—	TMR5GIF	TMR5IF	TMR3GIF	TMR3IF	TMR6IF	TRM4IF	109
TMRxH	Holding Register for the Most Significant Byte of the 16-bit TMR1/3/5 Register								217*
TMRxL	Holding Register for the Least Significant Byte of the 16-bit TMR1/3/5 Register								217*
TRISA	—	—	TRISA<5:4>		— <sup>(1)</sup>	TRISA<2:0>			138
TxCON	CS<1:0>		CKPS<1:0>		OSCF	SYNC	—	ON	225
TxGCON	GE	GPOL	GTM	GSPM	GGO/ DONE	GVAL	GSS<1:0>		226

**Legend:** — = unimplemented location, read as '0'. Shaded cells are not used by the Timer1 module.

\* Page provides register information.

**Note 1:** Unimplemented, read as '1'.

**Note 2:** PIC16(L)F1768/9 only.

## 23.0 TIMER2/4/6 MODULE

The Timer2/4/6 modules are 8-bit timers that can operate as free-running period counters or in conjunction with external signals that control Start, Run, Freeze and Reset operation in One-Shot and Monostable modes of operation. Sophisticated waveform control, such as pulse density modulation, are possible by combining the operation of these timers with other internal peripherals, such as the comparators and CCP modules. Features of the timer include:

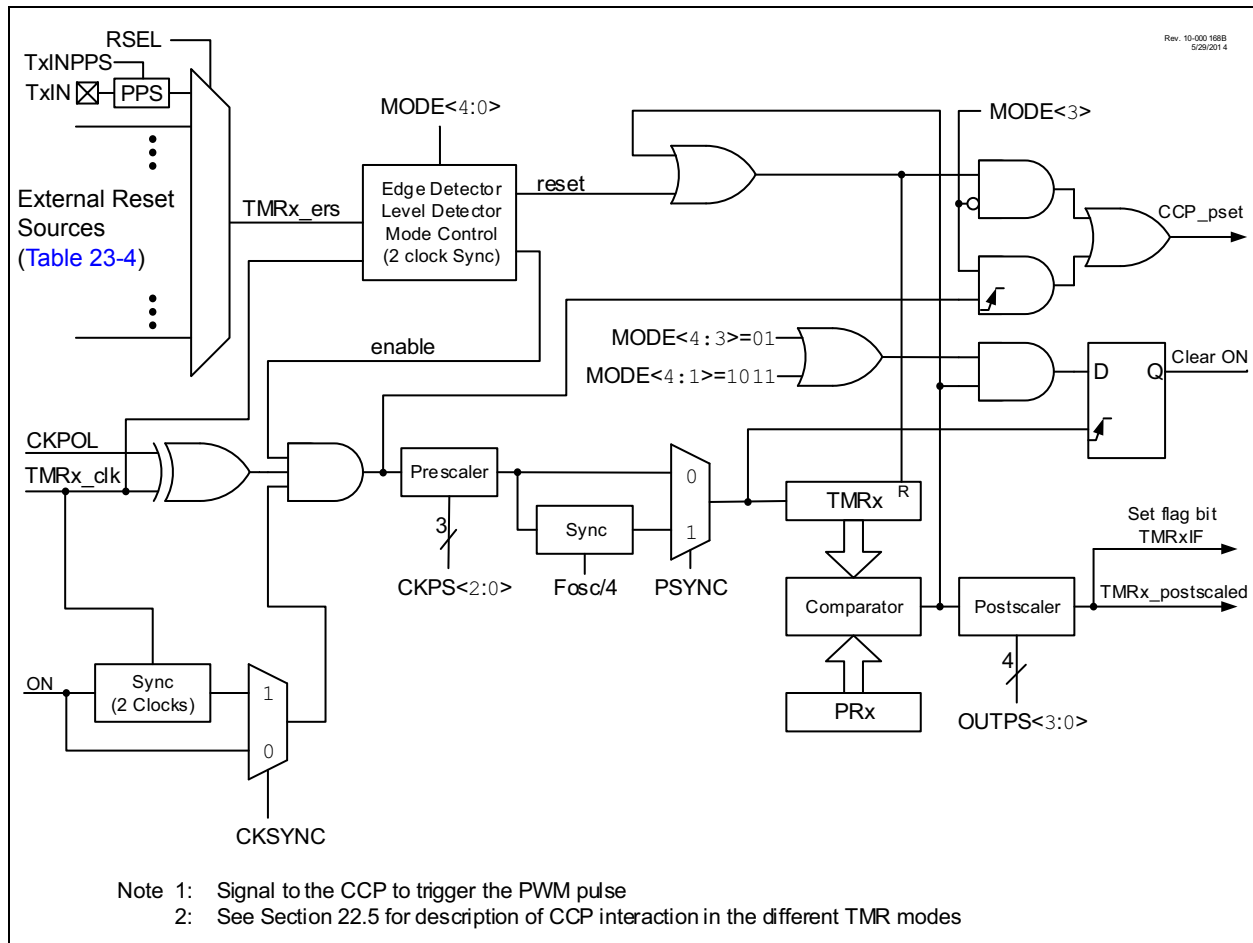
- 8-Bit Timer register
- 8-Bit Period register
- Selectable external hardware timer Resets
- Programmable prescaler (1:1 to 1:128)
- Programmable postscaler (1:1 to 1:16)
- Selectable synchronous/asynchronous operation
- Alternate clock sources
- Interrupt-on-period

- Three modes of operation:
  - Free-Running Period
  - One-Shot
  - Monostable

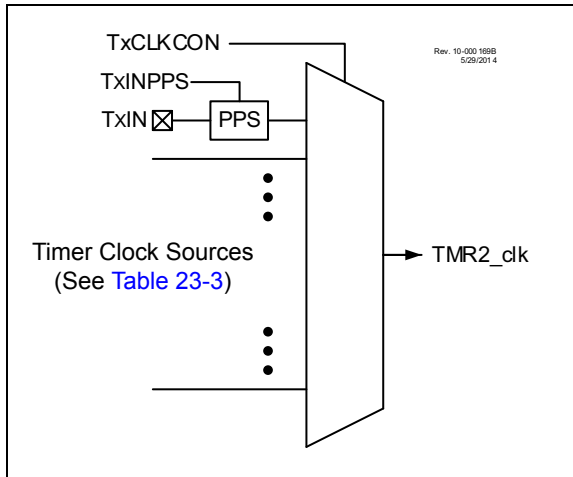
See [Figure 23-1](#) for a block diagram of Timer2. See [Figure 23-2](#) for the clock source block diagram.

**Note:** Three identical Timer2 modules are implemented on this device. The timers are named Timer2, Timer4 and Timer6. All references to Timer2 apply as well to Timer4 and Timer6. All references to T2PR apply as well to T4PR and T6PR.

**FIGURE 23-1: TIMER2 BLOCK DIAGRAM**



**FIGURE 23-2: TIMER2 CLOCK SOURCE BLOCK DIAGRAM**



## 23.1 Timer2 Operation

Timer2 operates in three major modes:

- Free-Running Period
- One-Shot
- Monostable

Within each mode, there are several options for starting, stopping and resetting. [Table 23-1](#) lists the options.

In all modes, the TMR2 Count register is incremented on the rising edge of the clock signal from the programmable prescaler. When TMR2 equals T2PR, a high level is output to the postscaler counter. TMR2 is cleared on the next clock input.

An external signal from hardware can also be configured to gate the timer operation or force a TMR2 count Reset. In Gate modes the counter stops when the gate is disabled and resumes when the gate is enabled. In Reset modes the TMR2 count is reset on either the level or edge from the external source.

The T2PR period register is double buffered. Software reads and writes the T2PR register. However, the timer uses a buffered PRx register for operation. Software does not have direct access to the buffered PRx register. The content of the PRx register is transferred to the buffer by any of the following events:

- A write to the TMR2 register
- A write to the T2CON register
- When TMR2 = PRx buffer and the prescaler rolls over
- An external Reset event

The TMR2 register is directly readable and writable. The TMR2 register is cleared and the T2PR register initializes to FFh on any device Reset. Both the prescaler and postscaler counters are cleared on the following events:

- A write to the TMR2 register

- A write to the T2CON register
- Any device Reset
- External Reset source event that resets the timer.

**Note:** TMR2 is not cleared when T2CON is written.

### 23.1.1 FREE-RUNNING PERIOD MODE

The value of TMR2 is compared to that of the Period register, T2PR, on each clock cycle. When the two values match, the comparator resets the value of TMR2 to 00h on the next cycle and increments the output postscaler counter. When the postscaler count equals the value in the OUTPS<4:0> bits of the TMRxCON1 register then a one clock period wide pulse occurs on the TMR2\_postscaled output, and the postscaler count is cleared.

### 23.1.2 ONE-SHOT MODE

The One-Shot mode is identical to the Free-Running Period mode except that the ON bit is cleared and the timer is stopped when TMR2 matches T2PR, and will not restart until the T2ON bit is cycled off and on. Postscaler OUTPS<4:0> values other than 0 are meaningless in this mode because the timer is stopped at the first period event and the postscaler is reset when the timer is restarted.

### 23.1.3 MONOSTABLE MODE

Monostable modes are similar to One-Shot modes except that the ON bit is not cleared and the timer can be restarted by an external Reset event.

## 23.2 Timer2 Output

The Timer2 module's primary output is TMR2\_postscaled, which pulses for a single TMR2\_clk period when the postscaler counter matches the value in the OUTPS bits of the TMR2xCON register. The T2PR postscaler is incremented each time the TMR2 value matches the T2PR value. This signal can be selected as an input to several other input modules:

- The ADC module as an auto-conversion trigger
- COG as an auto-shutdown source

In addition, the Timer2 is also used by the CCP module for pulse generation in PWM mode. Both the actual TMR2 value as well as other internal signals are sent to the CCP module to properly clock both the period and pulse width of the PWM signal. See [Section 24.6 "CCP/PWM Clock Selection"](#) for more details on setting up Timer2 for use with the CCP, as well as the timing diagrams in [Section 23.6 "Operation Examples"](#) for examples of how the varying Timer2 modes affect CCP PWM output.

## 23.3 External Reset Sources

In addition to the clock source, the Timer2 also takes in an external Reset source. This external Reset source is selected for Timer2, Timer4 and Timer6, with the T2RST, T4RST and T6RST registers, respectively. This source can control starting and stopping of the timer, as well as resetting the timer, depending on which mode the timer is in. The mode of the timer is

controlled by the MODE<4:0> bits of the TMRxHLT register. Edge-Triggered modes require six timer clock periods between external triggers. Level-Triggered modes require the triggering level to be at least three timer clock periods long. External triggers are ignored while in Debug Freeze mode.

## 23.4 Operating Modes

**TABLE 23-1: TIMER2 OPERATING MODES**

Mode	MODE<4:0>		Output Operation	Operation	Timer Control			
	<4:3>	<2:0>			Start	Reset	Stop	
Free-Running Period	00	000	Period Pulse	Software gate (Figure 23-4)	ON = 1	—	ON = 0	
		001		Hardware gate, active-high (Figure 23-5)	ON = 1 and TMRx_ers = 1	—	ON = 0 or TMRx_ers = 0	
		010		Hardware gate, active-low	ON = 1 and TMRx_ers = 0	—	ON = 0 or TMRx_ers = 1	
		011	Period Pulse with Hardware Reset	Rising or falling edge Reset	ON = 1	TMRx_ers ↓	ON = 0	
		100		Rising edge Reset (Figure 23-6)		TMRx_ers ↑		
		101		Falling edge Reset		TMRx_ers ↓		
		110		Low-level Reset		TMRx_ers = 0	ON = 0 or TMRx_ers = 0	
		111		High-level Reset (Figure 23-7)		TMRx_ers = 1	ON = 0 or TMRx_ers = 1	
One-Shot	01	000	One-Shot	Software start (Figure 23-8)	ON = 1	—	ON = 0 or next clock after TMRx = PRx (Note 2)	
		001	Edge-Triggered Start (Note 1)	Rising edge start (Figure 23-9)	ON = 1 and TMRx_ers ↑	—		
		010		Falling edge start	ON = 1 and TMRx_ers ↓	—		
		011		Any edge start	ON = 1 and TMRx_ers ↓	—		
		100	Edge-Triggered Start and Hardware Reset (Note 1)	Rising edge start and rising edge Reset (Figure 23-10)	ON = 1 and TMRx_ers ↑	TMRx_ers ↑		
		101		Falling edge start and falling edge Reset	ON = 1 and TMRx_ers ↓	TMRx_ers ↓		
		110		Rising edge start and low-level Reset (Figure 23-11)	ON = 1 and TMRx_ers ↑	TMRx_ers = 0		
		111		Falling edge start and high-level Reset	ON = 1 and TMRx_ers ↓	TMRx_ers = 1		
Mono-stable	10	000	Reserved					
		001	Edge-Triggered Start (Note 1)	Rising edge start (Figure 23-12)	ON = 1 and TMRx_ers ↑	—	ON = 0 or next clock after TMRx = PRx (Note 3)	
		010		Falling edge start	ON = 1 and TMRx_ers ↓	—		
		011		Any edge start	ON = 1 and TMRx_ers ↓	—		
		Reserved	100	Reserved				
		Reserved	101	Reserved				
One-shot	11	110	Level-Triggered Start and Hardware Reset	High-level start and low-level Reset (Figure 23-13)	ON = 1 and TMRx_ers = 1	TMRx_ers = 0	ON = 0 or held in Reset (Note 2)	
		111		Low-level start and high-level Reset	ON = 1 and TMRx_ers = 0	TMRx_ers = 1		
Reserved	11	xxx	Reserved					

**TABLE 23-1: TIMER2 OPERATING MODES**

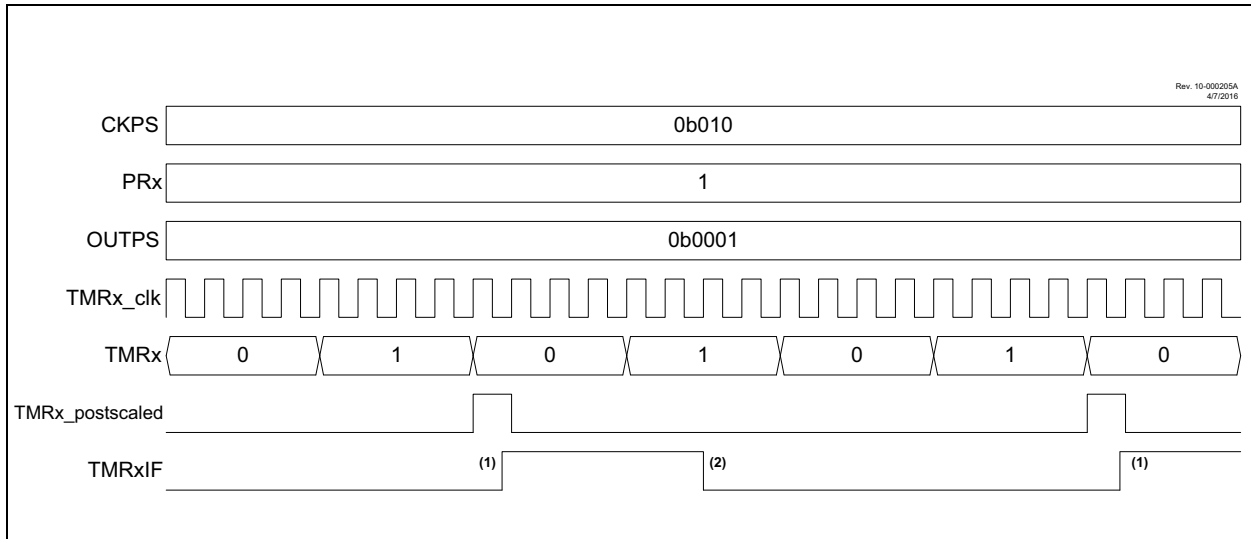
Mode	MODE<4:0>		Output Operation	Operation	Timer Control		
	<4:3>	<2:0>			Start	Reset	Stop

- Note** 1: If ON = 0, then an edge is required to restart the timer after ON = 1.  
2: When TMRx = PRx, then the next clock clears ON and stops TMRx at 00h.  
3: When TMRx = PRx, then the next clock stops TMRx at 00h but does not clear ON.

## 23.5 Timer2 Interrupt

Timer2 can also generate a device interrupt. The interrupt is generated when the postscaler counter matches one of 16 postscale options (from 1:1 through 1:16), which are selected with the postscaler control bits, OUTPS<3:0> of the T2CON register. The interrupt is enabled by setting the TMR2IE interrupt enable bit of the PIE1 register. Interrupt timing is illustrated in Figure 23-3.

**FIGURE 23-3: TIMER2 PRESCALER, POSTSCALER AND INTERRUPT TIMING DIAGRAM**





## 23.6 Operation Examples

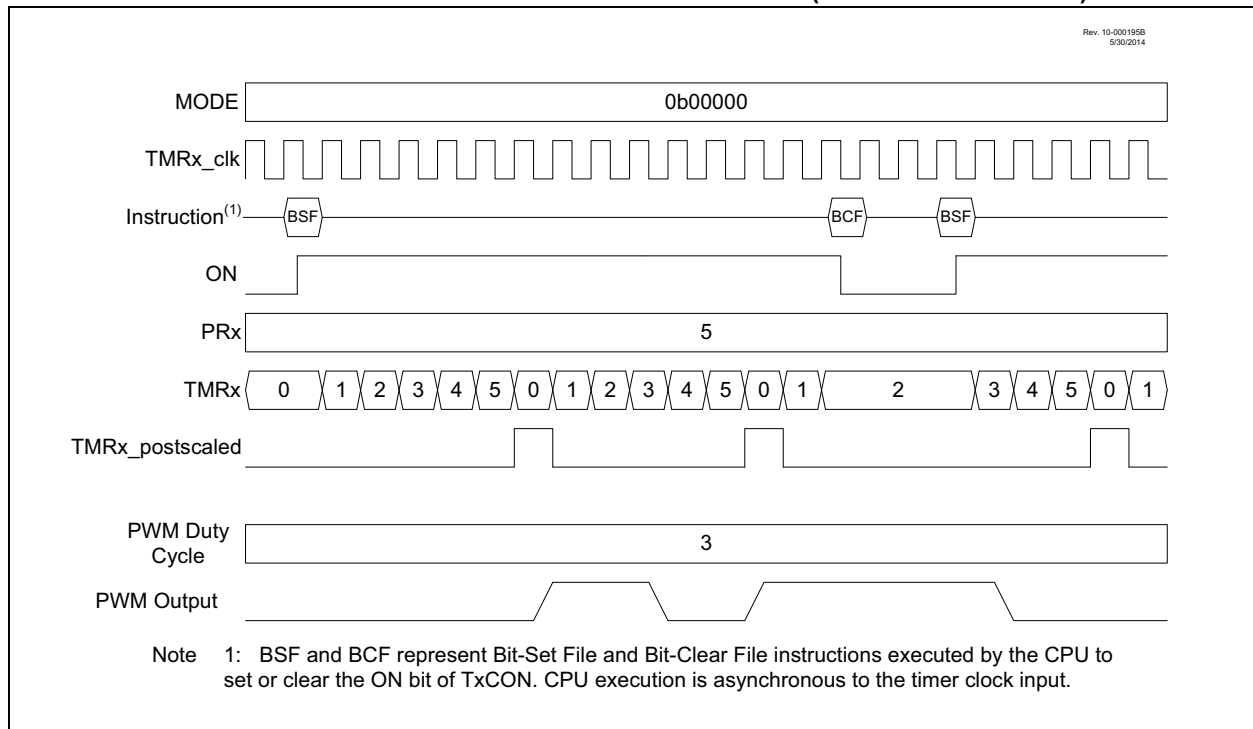
Unless otherwise specified, the following notes apply to the following timing diagrams:

- Both the prescaler and postscaler are set to 1:1 (both the CKPSx and OUTPSx bits in the TxCON register are cleared).
- The diagrams illustrate any clock except FOSC/4 and show clock-sync delays of at least two full cycles for both ON and Timer2\_ers. When using FOSC/4, the clock-sync delay is at least one instruction period for Timer2\_ers; ON applies in the next instruction period.
- The PWM duty cycle and PWM output are illustrated assuming that the timer is used for the PWM function of the CCP module, as described in **Section 24.6 “CCP/PWM Clock Selection”**. The signals are not a part of the Timer2 module.

### 23.6.1 SOFTWARE GATE MODE

This mode corresponds to legacy Timer2 operation. The timer increments with each clock input when ON = 1 and does not increment when ON = 0. When the TMRx count equals the PRx period count, the timer resets on the next clock and continues counting from 0. Operation with the ON bit software controlled is illustrated in [Figure 23-4](#). With PRx = 5, the counter advances until TMRx = 5, and goes to zero with the next clock.

**FIGURE 23-4: SOFTWARE GATE MODE TIMING DIAGRAM (MODE<4:0> = 00000)**



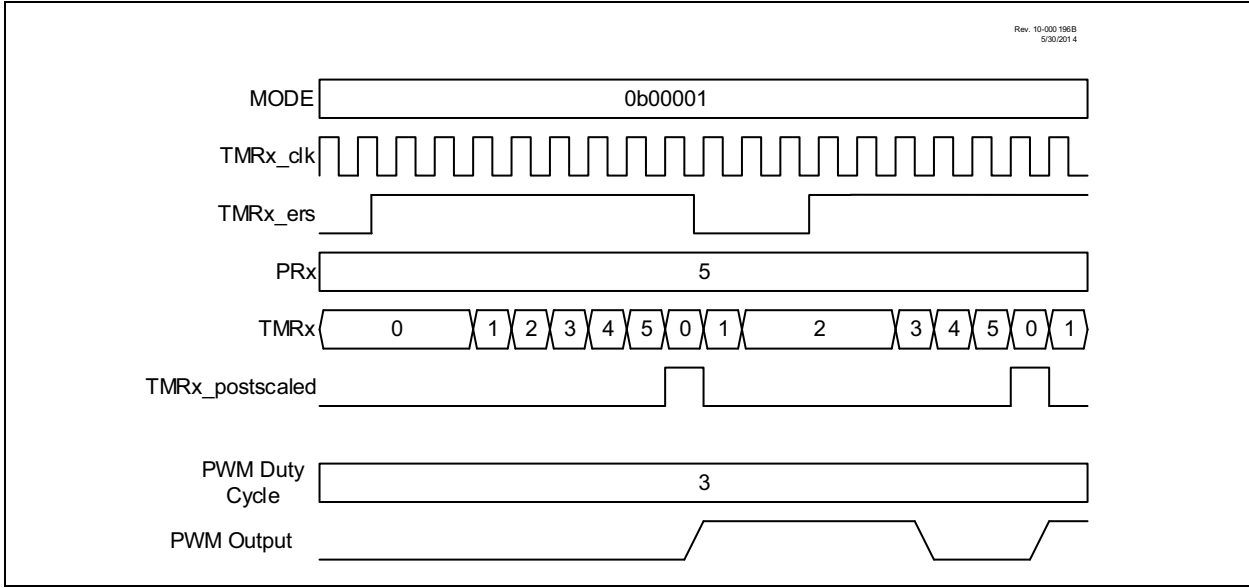
## 23.6.2 HARDWARE GATE MODE

The Hardware Gate modes operate the same as the Software Gate mode, except the TMRx\_ers external signal can also gate the timer. When used with the CCP, the gating extends the PWM period. If the timer is stopped when the PWM output is high, then the duty cycle is also extended.

When MODE<4:0> = 00001, then the timer is stopped when the external signal is high. When MODE<4:0> = 00010, then the timer is stopped when the external signal is low.

Figure 23-5 illustrates the Hardware Gating mode for MODE<4:0> = 00001 in which a high input level starts the counter.

**FIGURE 23-5: HARDWARE GATE MODE TIMING DIAGRAM (MODE<4:0> = 00001)**



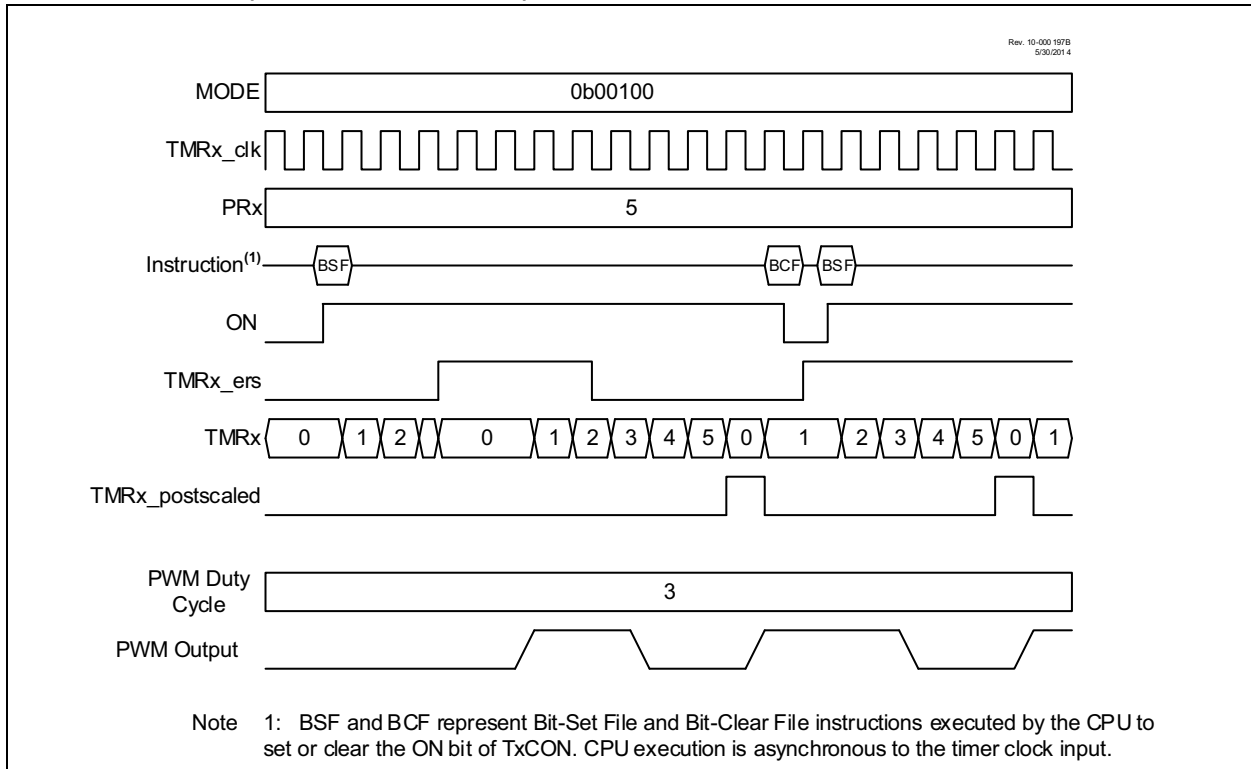
## 23.6.3 EDGE-TRIGGERED HARDWARE LIMIT MODE

In Hardware Limit mode, the timer can be reset by the TMRx\_ers external signal before the timer reaches the period count. Three types of Resets are possible:

- Reset on rising or falling edge (MODE<4:0> = 00011)
- Reset on rising edge (MODE<4:0> = 00100)
- Reset on falling edge (MODE<4:0> = 00101)

When the timer is used in conjunction with the CCP in PWM mode, then an early Reset shortens the period and restarts the PWM pulse after a two-clock delay. Refer to [Figure 23-6](#).

**FIGURE 23-6: EDGE-TRIGGERED HARDWARE LIMIT MODE TIMING DIAGRAM (MODE<4:0> = 00100)**



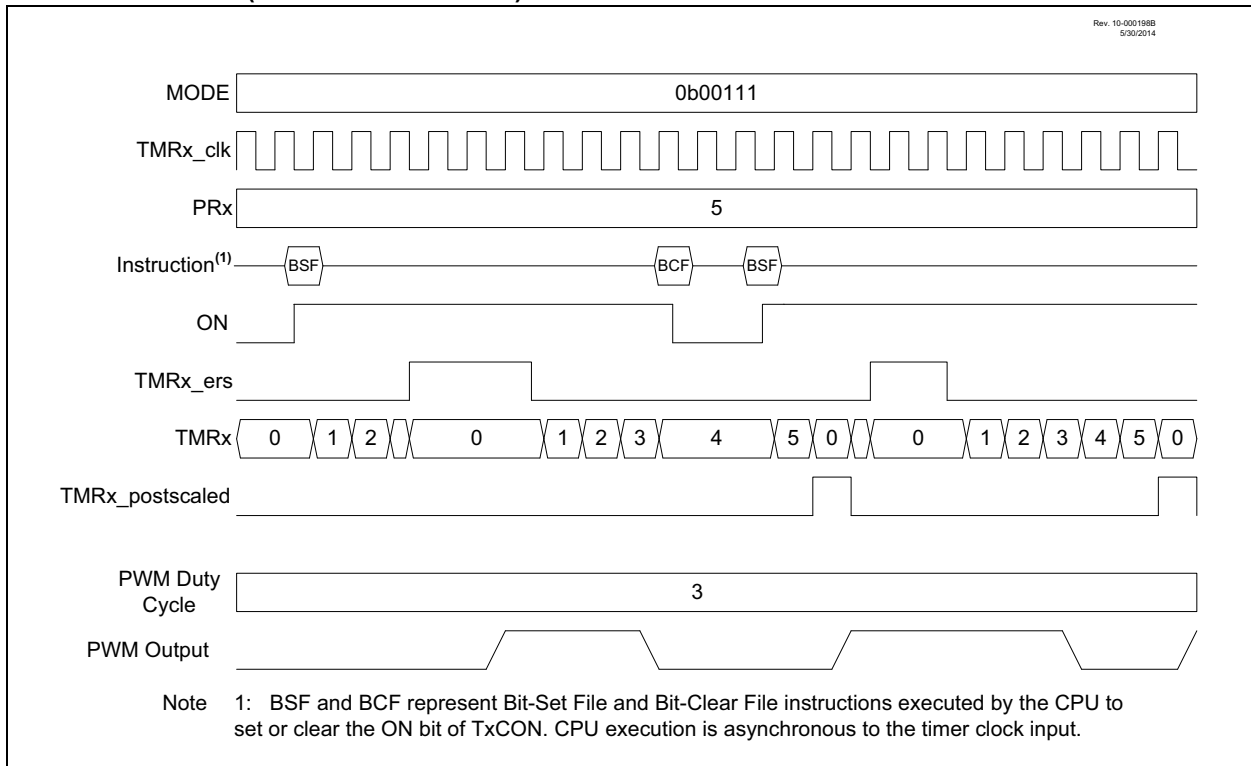
## 23.6.4 LEVEL-TRIGGERED HARDWARE LIMIT MODE

In the Level-Triggered Hardware Limit Timer modes, the counter is reset by high or low levels of the external signal, TMRx\_ers, as shown in Figure 23-7. Selecting MODE<4:0> = 00110 will cause the timer to reset on a low-level external signal. Selecting MODE<4:0> = 00111 will cause the timer to reset on a high-level external signal. In the example, the counter is reset while TMRx\_ers = 1. ON is controlled by BSF and BCF instructions. When ON = 0, the external signal is ignored.

When the CCP uses the timer as the PWM time base, then the PWM output will be set high when the timer starts counting and then set low only when the timer count matches the CCPRx value. The timer is reset when either the timer count matches the PRx value or two clock periods after the external Reset signal goes true and stays true.

The timer starts counting, and the PWM output is set high, on either the clock following the PRx match or two clocks after the external Reset signal relinquishes the Reset. The PWM output will remain high until the timer counts up to match the CCPRx pulse-width value. If the external Reset signal goes true while the PWM output is high then the PWM output will remain high until the Reset signal is released allowing the timer to count up to match the CCPRx value.

**FIGURE 23-7: LEVEL-TRIGGERED HARDWARE LIMIT MODE TIMING DIAGRAM (MODE<4:0> = 00111)**

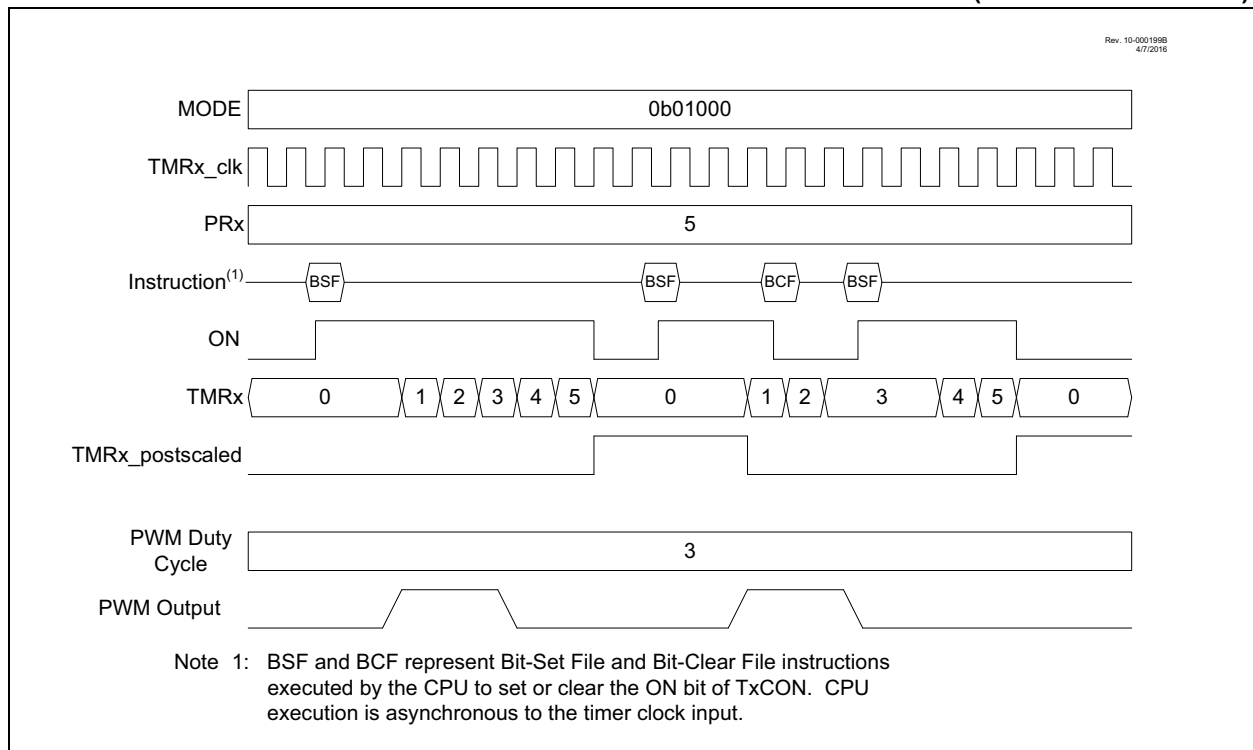


## 23.6.5 SOFTWARE START ONE-SHOT MODE

In One-Shot mode, the timer resets and the ON bit is cleared when the timer value matches the PRx period value. The ON bit must be set by software to start another timer cycle. Setting MODE<4:0> = 01000 selects One-Shot mode, which is illustrated in Figure 23-8. In the example, ON is controlled by the BSF and BCF instructions. In the first case, a BSF instruction sets ON and the counter runs to completion and clears ON. In the second case, a BSF instruction starts the cycle, BCF/BSF instructions turn the counter off and on during the cycle, and then it runs to completion.

When One-Shot mode is used in conjunction with the CCP PWM operation, the PWM pulse drive starts concurrent with setting the ON bit. Clearing the ON bit while the PWM drive is active will extend the PWM drive. The PWM drive will terminate when the timer value matches the CCPRx pulse-width value. The PWM drive will remain off until software sets the ON bit to start another cycle. If software clears the ON bit after the CCPRx match, but before the PRx match, then the PWM drive will be extended by the length of time the ON bit remains cleared. Another timing cycle can only be initiated by setting the ON bit after it has been cleared by a PRx period count match.

**FIGURE 23-8: SOFTWARE START ONE-SHOT MODE TIMING DIAGRAM (MODE<4:0> = 01000)**



## 23.6.6 EDGE-TRIGGERED ONE-SHOT MODE

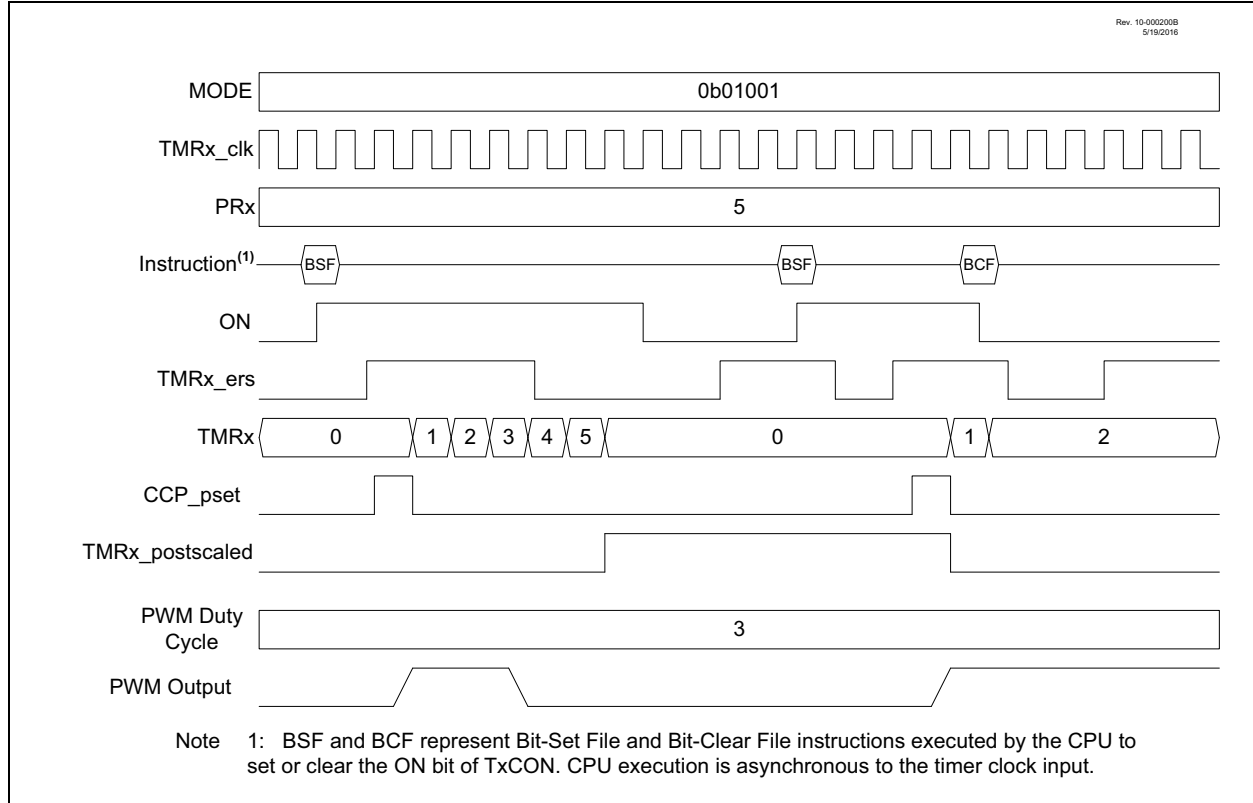
The Edge-Triggered One-Shot modes start the timer on an edge from the external signal input, after the ON bit is set, and clear the ON bit when the timer matches the PRx period value. The following edges will start the timer:

- Rising edge (MODE<4:0> = 01001)
- Falling edge (MODE<4:0> = 01010)
- Rising or falling edge (MODE<4:0> = 01011)

If the timer is halted by clearing the ON bit, then another TMRx\_ers edge is required after the ON bit is set to resume counting. [Figure 23-9](#) illustrates operation in the rising edge One-Shot mode.

When Edge-Triggered One-Shot mode is used in conjunction with the CCP, then the edge-trigger will activate the PWM drive and the PWM drive will deactivate when the timer matches the CCPRx pulse-width value and stay deactivated when the timer halts at the PRx period count match.

**FIGURE 23-9: EDGE-TRIGGERED ONE-SHOT MODE TIMING DIAGRAM (MODE<4:0> = 01001)**



## 23.6.7 EDGE-TRIGGERED HARDWARE LIMIT ONE-SHOT MODE

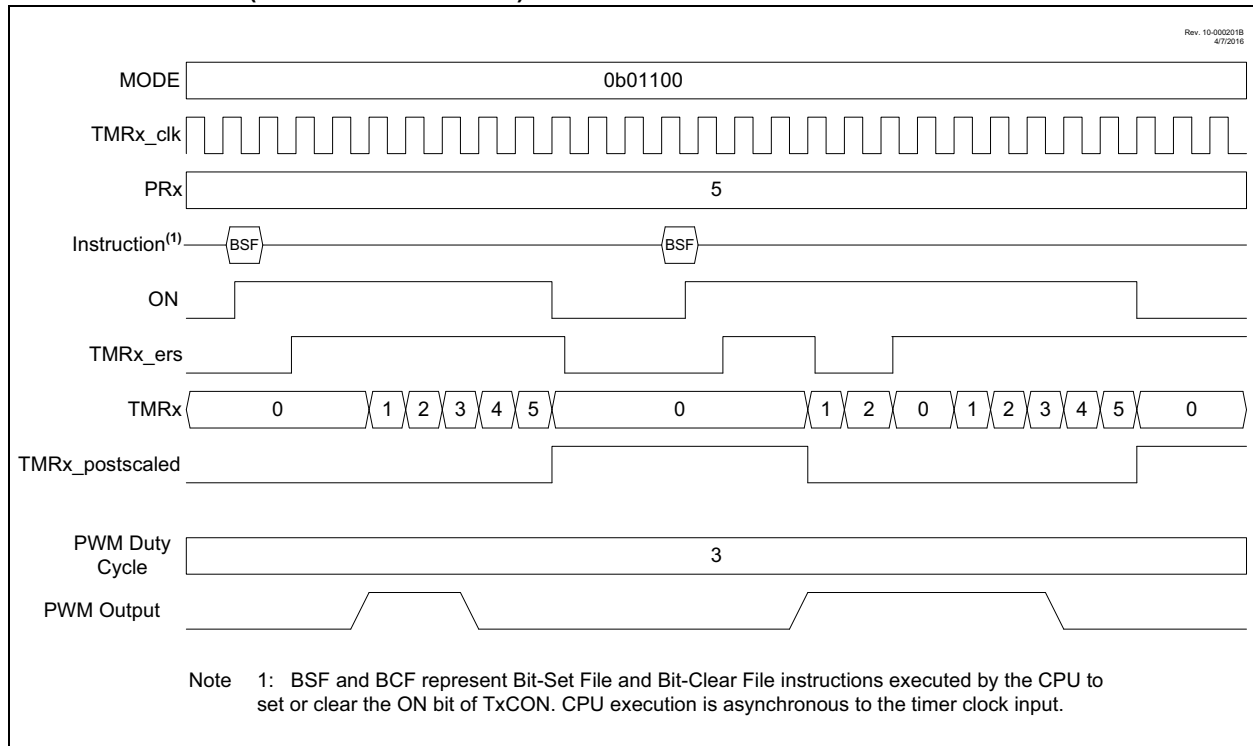
In Edge-Triggered Hardware Limit One-Shot modes, the timer starts on the first external signal edge after the ON bit is set and resets on all subsequent edges. Only the first edge after the ON bit is set is needed to start the timer. The counter will resume counting automatically, two clocks after all subsequent external Reset edges. Edge triggers are as follows:

- Rising edge start and Reset (MODE<4:0> = 01100)
- Falling edge start and Reset (MODE<4:0> = 01101)

The timer resets and clears the ON bit when the timer value matches the PRx period value. External signal edges will have no effect until after software sets the ON bit. [Figure 23-10](#) illustrates the rising edge hardware limit one-shot operation.

When this mode is used in conjunction with the CCP then the first starting edge trigger, and all subsequent Reset edges, will activate the PWM drive. The PWM drive will deactivate when the timer matches the CCPRx pulse-width value and stay deactivated until the timer halts at the PRx period match unless an external signal edge resets the timer before the match occurs.

**FIGURE 23-10: EDGE-TRIGGERED HARDWARE LIMIT ONE-SHOT MODE TIMING DIAGRAM (MODE<4:0> = 01100)**



## 23.6.8 LEVEL RESET, EDGE-TRIGGERED HARDWARE LIMIT ONE-SHOT MODES

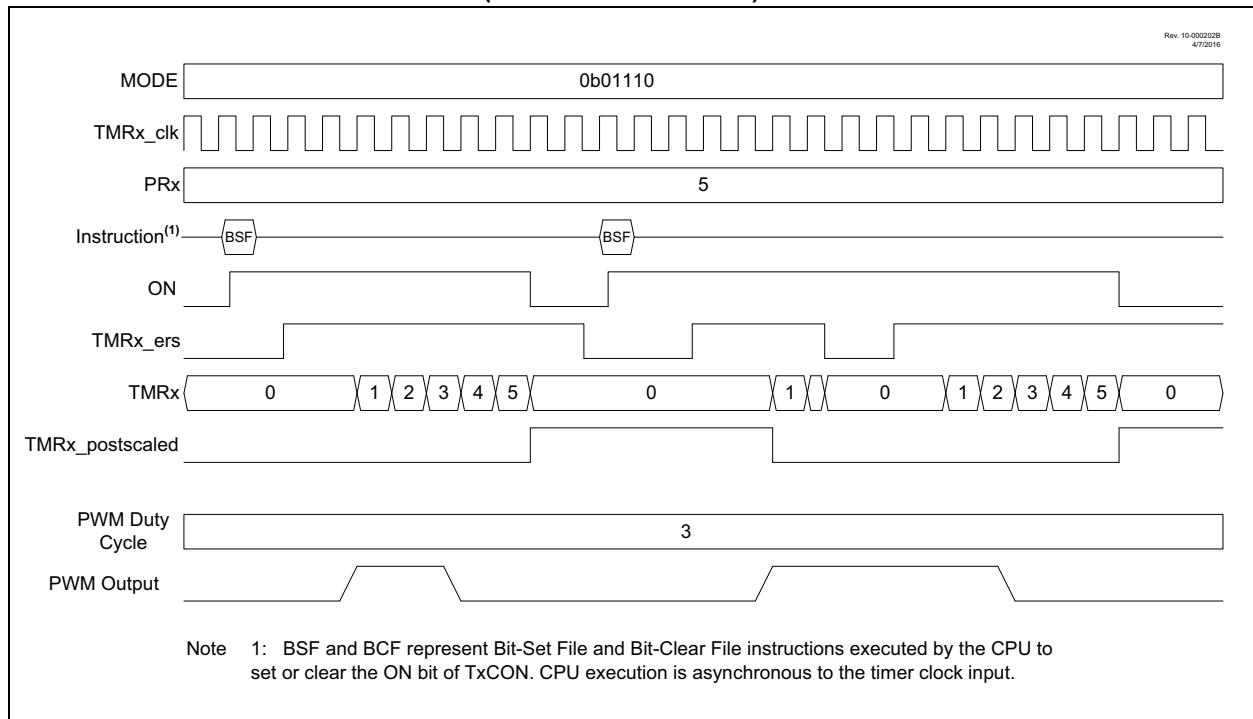
In Level-Triggered One-Shot mode, the timer count is reset on the external signal level and starts counting on the rising/falling edge of the transition from Reset level to the active level while the ON bit is set. Reset levels are selected as follows:

- Low Reset level (MODE<4:0> = 01110)
- High Reset level (MODE<4:0> = 01111)

When the timer count matches the PRx period count, the timer is reset and the ON bit is cleared. When the ON bit is cleared by either a PRx match or by software control, a new external signal edge is required after the ON bit is set to start the counter.

When Level-Triggered Reset One-Shot mode is used in conjunction with the CCP PWM operation, the PWM drive goes active with the external signal edge that starts the timer. The PWM drive goes inactive when the timer count equals the CCPRx pulse-width count. The PWM drive does not go active when the timer count clears at the PRx period count match.

**FIGURE 23-11: LOW-LEVEL RESET, EDGE-TRIGGERED HARDWARE LIMIT ONE-SHOT MODE TIMING DIAGRAM (MODE<4:0> = 01110)**





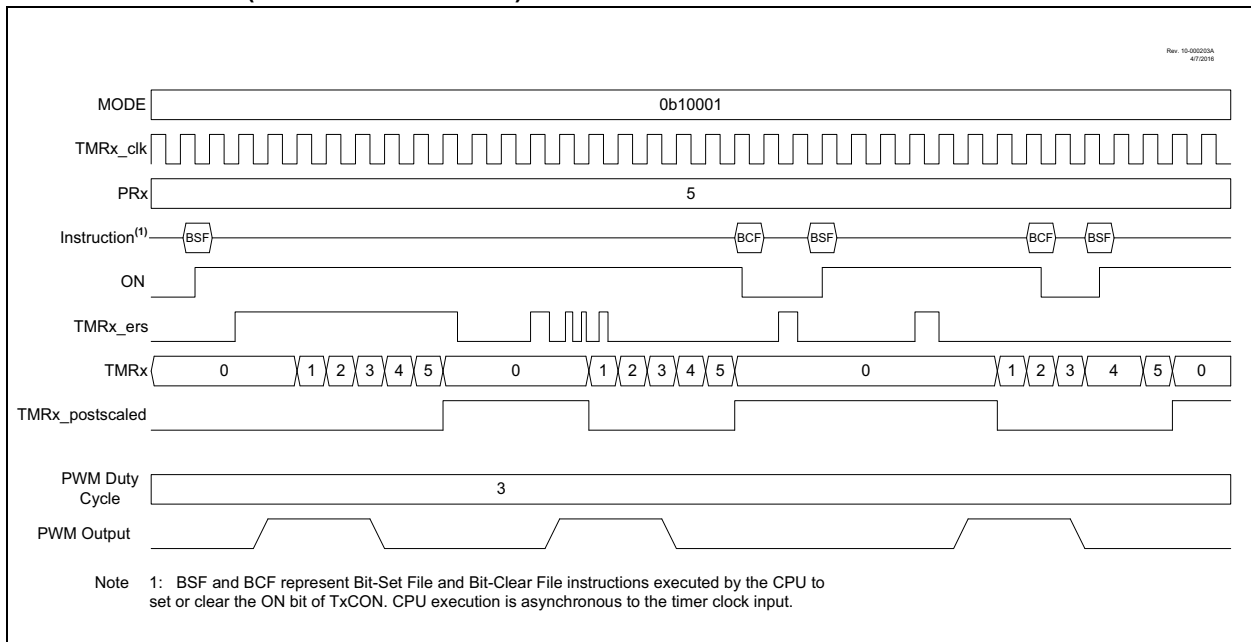
## 23.6.9 EDGE-TRIGGERED MONOSTABLE MODES

The Edge-Triggered Monostable modes start the timer on an edge from the external Reset signal input, after the ON bit is set, and stop incrementing the timer when the timer matches the PRx period value. The following edges will start the timer:

- Rising edge (MODE<4:0> = 10001)
- Falling edge (MODE<4:0> = 10010)
- Rising or falling edge (MODE<4:0> = 10011)

When an Edge-Triggered Monostable mode is used in conjunction with the CCP PWM operation, the PWM drive goes active with the external Reset signal edge that starts the timer, but will not go active when the timer matches the PRx value. While the timer is incrementing, additional edges on the external Reset signal will not affect the CCP PWM.

**FIGURE 23-12: RISING EDGE-TRIGGERED MONOSTABLE MODE TIMING DIAGRAM (MODE<4:0> = 10001)**



## 23.6.10 LEVEL-TRIGGERED HARDWARE LIMIT ONE-SHOT MODES

The Level-Triggered Hardware Limit One-Shot modes hold the timer in Reset on an external Reset level, and start counting when both the ON bit is set and the external signal is not at the Reset level. If one of either of the external signals is not in Reset, or the ON bit is set, then the other signal being set/made active will start the timer. Reset levels are selected as follows:

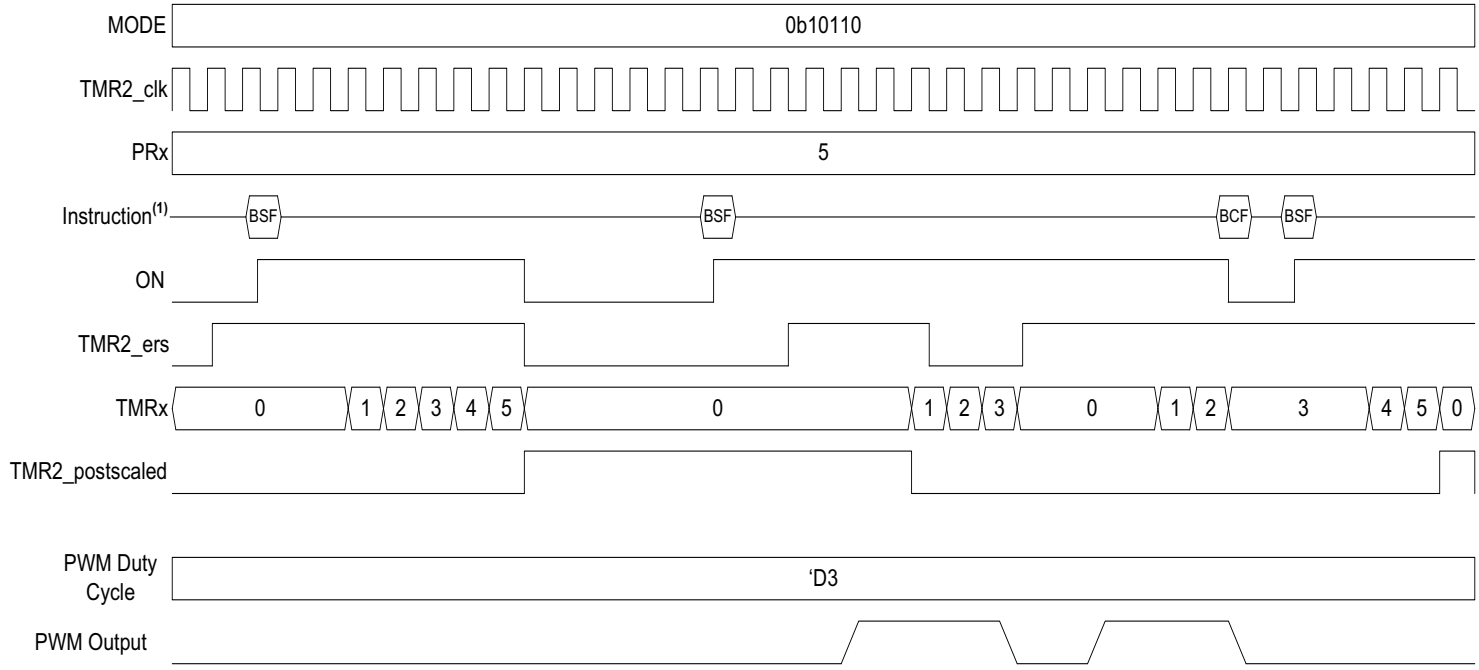
- Low Reset level (MODE<4:0> = 10110)
- High Reset level (MODE<4:0> = 10111)

When the timer count matches the PRx period count, the timer is reset and the ON bit is cleared. When the ON bit is cleared by either a PRx match or by software control, the timer will stay in Reset until both the ON bit is set and the external signal is not at the Reset level.

When Level-Triggered Hardware Limit One-Shot modes are used in conjunction with the CCP PWM operation, the PWM drive goes active with either the external signal edge or the setting of the ON bit, whichever of the two starts the timer.

**FIGURE 23-13: LEVEL-TRIGGERED HARDWARE LIMIT ONE-SHOT MODE TIMING DIAGRAM (MODE<4:0> = 101110)**

Rev. 10-000204A  
4/7/2016



Note 1: BSF and BCF represent Bit-Set File and Bit-Clear File instructions executed by the CPU to set or clear the ON bit of TxCON. CPU execution is asynchronous to the timer clock input.

## 23.7 PR2 Period Register

The T2PR Period register is double-buffered. Software reads and writes the T2PR register. However, the timer uses a buffered T2PR register for operation. Software does not have direct access to the buffered T2PR register. The contents of the T2PR register are transferred to the buffer by any of the following events:

- A write to the TMR2 register
- A write to the TMR2CON register
- When TMR2 = T2PR buffer and the prescaler rolls over
- An external Reset event

## 23.8 Timer2 Operation During Sleep

When PSYNC = 1, Timer2 cannot be operated while the processor is in Sleep mode. The contents of the TMR2 and T2PR registers will remain unchanged while the processor is in Sleep mode.

When PSYNC = 0, Timer2 will operate in Sleep as long as the clock source selected is also still running. Selecting the LFINTOSC, MFINTOSC or HFINTOSC oscillator as the timer clock source will keep the selected oscillator running during Sleep.

## 23.9 Register Definitions: Timer2/4/6 Control

Long bit name prefixes for the Timer2/4/6 peripherals are shown in [Table 23-2](#). Refer to [Section 1.1.2.2 “Long Bit Names”](#) for more information.

**TABLE 23-2: BIT NAME PREFIXES**

Peripheral	Bit Name Prefix
Timer2	T2
Timer4	T4
Timer6	T6

**REGISTER 23-1: TxCLKCON: TIMERx CLOCK SELECTION REGISTER**

U-0	U-0	U-0	U-0	R/W-0/0	R/W-0/0	R/W-0/0	R/W-0/0
—	—	—	—	CS<3:0>			
bit 7				bit 0			

**Legend:**

R = Readable bit	W = Writable bit	
u = Bit is unchanged	x = Bit is unknown	U = Unimplemented bit, read as '0'
'1' = Bit is set	'0' = Bit is cleared	-n/n = Value at POR and BOR/Value at all other Resets

bit 7-4      **Unimplemented:** Read as '0'  
bit 3-0      **CS<3:0>:** Timerx Clock Selection bits  
See [Table 23-3](#).

**TABLE 23-3: TIMERx CLOCK SOURCES**

CS<3:0>	Timer2	Timer4	Timer6
1011-1111	Reserved	Reserved	Reserved
1010	LC3_out	LC3_out	LC3_out
1001	LC2_out	LC2_out	LC2_out
1000	LC1_out	LC1_out	LC1_out
0111	ZCD_out	ZCD_out	ZCD_out
0110	SOSC	SOSC	SOSC
0101	MFINTOSC	MFINTOSC	MFINTOSC
0100	LFINTOSC	LFINTOSC	LFINTOSC
0011	HFINTOSC	HFINTOSC	HFINTOSC
0010	Fosc	Fosc	Fosc
0001	Fosc/4	Fosc/4	Fosc/4
0000	Pin selected by T2INPPS	Pin selected by T4INPPS	Pin selected by T6INPPS

## REGISTER 23-2: TxCON: TIMERx CONTROL REGISTER

R/W/HC-0/0	R/W-0/0	R/W-0/0	R/W-0/0	R/W-0/0	R/W-0/0	R/W-0/0	R/W-0/0
ON <sup>(1)</sup>	CKPS<2:0>			OUTPS<3:0>			
bit 7							bit 0

### Legend:

R = Readable bit	W = Writable bit	U = Unimplemented bit, read as '0'
u = Bit is unchanged	x = Bit is unknown	-n/n = Value at POR and BOR/Value at all other Resets
'1' = Bit is set	'0' = Bit is cleared	HC = Hardware Clearable bit

bit 7      **ON:** Timerx On bit  
 1 = Timerx is on  
 0 = Timerx is off; all counters and state machines are reset

bit 6-4      **CKPS<2:0>:** Timer2 Type Clock Prescale Select bits  
 111 = 1:128 Prescaler  
 110 = 1:64 Prescaler  
 101 = 1:32 Prescaler  
 100 = 1:16 Prescaler  
 011 = 1:8 Prescaler  
 010 = 1:4 Prescaler  
 001 = 1:2 Prescaler  
 000 = 1:1 Prescaler

bit 3-0      **OUTPS<3:0>:** Timerx Output Postscaler Select bits  
 1111 = 1:16 Postscaler  
 1110 = 1:15 Postscaler  
 1101 = 1:14 Postscaler  
 1100 = 1:13 Postscaler  
 1011 = 1:12 Postscaler  
 1010 = 1:11 Postscaler  
 1001 = 1:10 Postscaler  
 1000 = 1:9 Postscaler  
 0111 = 1:8 Postscaler  
 0110 = 1:7 Postscaler  
 0101 = 1:6 Postscaler  
 0100 = 1:5 Postscaler  
 0011 = 1:4 Postscaler  
 0010 = 1:3 Postscaler  
 0001 = 1:2 Postscaler  
 0000 = 1:1 Postscaler

**Note 1:** In certain modes, the ON bit will be auto-cleared by hardware. See [Section 23.6 “Operation Examples”](#).

## REGISTER 23-3: TxHLT: TIMERx HARDWARE LIMIT CONTROL REGISTER

R/W-0/0	R/W-0/0	R/W-0/0	R/W-0/0	R/W-0/0	R/W-0/0	R/W-0/0	R/W-0/0
PSYNC <sup>(1,2)</sup>	CKPOL <sup>(3)</sup>	CKSYNC <sup>(4,5)</sup>	MODE<4:0> <sup>(6,7)</sup>				
bit 7							bit 0

### Legend:

R = Readable bit	W = Writable bit	
u = Bit is unchanged	x = Bit is unknown	U = Unimplemented bit, read as '0'
'1' = Bit is set	'0' = Bit is cleared	-n/n = Value at POR and BOR/Value at all other Resets

- bit 7      **PSYNC:** Timerx Prescaler Synchronization Enable bit<sup>(1,2)</sup>  
 1 = TMRx prescaler output is synchronized to Fosc/4  
 0 = TMRx prescaler output is not synchronized to Fosc/4
- bit 6      **CKPOL:** Timerx Clock Polarity Selection bit<sup>(3)</sup>  
 1 = Falling edge of input clock clocks timer/prescaler  
 0 = Rising edge of input clock clocks timer/prescaler
- bit 5      **CKSYNC:** Timerx Clock Synchronization Enable bit<sup>(4,5)</sup>  
 1 = ON register bit is synchronized to TMR2\_clk input  
 0 = ON register bit is not synchronized to TMR2\_clk input
- bit 4-0    **MODE<4:0>:** Timerx Control Mode Selection bits<sup>(6,7)</sup>  
 See [Table 23-1](#).

- Note 1:** Setting this bit ensures that reading TMRx will return a valid value.
- 2:** When this bit is '1', Timer2 cannot operate in Sleep mode.
- 3:** CKPOL should not be changed while ON = 1.
- 4:** Setting this bit ensures glitch-free operation when the ON bit is enabled or disabled.
- 5:** When this bit is set, then the timer operation will be delayed by two TMRx input clocks after the ON bit is set.
- 6:** Unless otherwise indicated, all modes start upon ON = 1 and stop upon ON = 0 (stops occur without affecting the value of TMRx).
- 7:** When TMRx = PRx, the next clock clears TMRx, regardless of the operating mode.

# PIC16(L)F1764/5/8/9

**REGISTER 23-4: TxRST: TIMERx EXTERNAL RESET SIGNAL SELECTION REGISTER**

U-0	U-0	U-0	R/W-0/0	R/W-0/0	R/W-0/0	R/W-0/0	R/W-0/0
—	—	—	RSEL<4:0>				
bit 7							bit 0

**Legend:**

R = Readable bit	W = Writable bit	
u = Bit is unchanged	x = Bit is unknown	U = Unimplemented bit, read as '0'
'1' = Bit is set	'0' = Bit is cleared	-n/n = Value at POR and BOR/Value at all other Resets

bit 7-5      **Unimplemented:** Read as '0'  
bit 4-0      **RSEL<4:0>:** Timerx External Reset Signal Source Selection bits  
See [Table 23-4](#).

**TABLE 23-4: EXTERNAL RESET SOURCES**

RSEL<4:0>	Timer2	Timer4	Timer6
10010-11111	Reserved	Reserved	Reserved
10001	LC3_out	LC3_out	LC3_out
10000	LC2_out	LC2_out	LC2_out
01111	LC1_out	LC1_out	LC1_out
01110	ZCD_out	ZCD_out	ZCD_out
01101	sync_C4OUT <sup>(1)</sup>	sync_C4OUT <sup>(1)</sup>	sync_C4OUT <sup>(1)</sup>
01100	sync_C3OUT <sup>(1)</sup>	sync_C3OUT <sup>(1)</sup>	sync_C3OUT <sup>(1)</sup>
01011	sync_C2OUT	sync_C2OUT	sync_C2OUT
01010	sync_C1OUT	sync_C1OUT	sync_C1OUT
01001	PWM6_out <sup>(1)</sup>	PWM6_out <sup>(1)</sup>	PWM6_out <sup>(1)</sup>
01000	PWM5_out	PWM5_out	PWM5_out
00111	PWM4_out <sup>(1)</sup>	PWM4_out <sup>(1)</sup>	PWM4_out <sup>(1)</sup>
00110	PWM3_out	PWM3_out	PWM3_out
00101	CCP2_out <sup>(1)</sup>	CCP2_out <sup>(1)</sup>	CCP2_out <sup>(1)</sup>
00100	CCP1_out	CCP1_out	CCP1_out
00011	TMR6_postscaled	TMR6_postscaled	Reserved
00010	TMR4_postscaled	Reserved	TMR4_postscaled
00001	Reserved	TMR2_postscaled	TMR2_postscaled
00000	Pin selected by T2INPPS	Pin selected by T4INPPS	Pin selected by T6INPPS

**Note 1:** PIC16(L)F1768/9 devices only.



# PIC16(L)F1764/5/8/9

**TABLE 23-5: SUMMARY OF REGISTERS ASSOCIATED WITH TIMER2**

Name	Bit 7	Bit 6	Bit 5	Bit 4	Bit 3	Bit 2	Bit 1	Bit 0	Register on Page
CCP1CON	EN	OE	OUT	FMT	MODE<3:0>				258
CCP2CON <sup>(2)</sup>	EN	OE	OUT	FMT	MODE<3:0>				258
INTCON	GIE	PEIE	TMR0IE	INTE	IOCIE	TMR0IF	INTF	IOCIF	101
PIE1	TMR1GIE	ADIE	RCIE	TXIE	SSP1IE	CCP1IE	TMR2IE	TMR1IE	102
PIE4	—	—	TMR5GIE	TMR5IE	TMR3GIE	TMR3IE	TMR6IE	TRM4IE	105
PIR1	TMR1GIF	ADIF	RCIF	TXIF	SSP1IF	CCP1IF	TMR2IF	TMR1IF	106
PIR4	—	—	TMR5GIF	TMR5IF	TMR3GIF	TMR3IF	TMR6IF	TRM4IF	109
T2PR	Timer2 Module Period Register								229*
TMR2	Holding Register for the 8-Bit TMR2 Register								229*
T2CON	ON	CKPS<2:0>			OUTPS<3:0>				246
T2CLKCON	—	—	—	—	CS<3:0>				245
T2RST	—	—	—	—	RSEL<3:0>				248
T2HLT	PSYNC	CKPOL	CKSYNC	MODE<4:0>				247	
T4PR	Timer4 Module Period Register								229*
TMR4	Holding Register for the 8-Bit TMR4 Register								229*
T4CON	ON	CKPS<2:0>			OUTPS<3:0>				246
T4CLKCON	—	—	—	—	CS<3:0>				245
T4RST	—	—	—	—	RSEL<3:0>				248
T4HLT	PSYNC	CKPOL	CKSYNC	MODE<4:0>				247	
T6PR	Timer6 Module Period Register								229*
TMR6	Holding Register for the 8-Bit TMR6 Register								229*
T6CON	ON	CKPS<2:0>			OUTPS<3:0>				246
T6CLKCON	—	—	—	—	CS<3:0>				245
T6RST	—	—	—	—	RSEL<3:0>				248
T6HLT	PSYNC	CKPOL	CKSYNC	MODE<4:0>				247	

**Legend:** — = unimplemented location, read as '0'. Shaded cells are not used for the Timer2 module.

\* Page provides register information.

**Note 1:** PIC16(L)F1768/9 only.

## 24.0 CAPTURE/COMPARE/PWM MODULES

The Capture/Compare/PWM module is a peripheral which allows the user to time and control different events, and to generate Pulse-Width Modulation (PWM) signals. In Capture mode, the peripheral allows the timing of the duration of an event. The Compare mode allows the user to trigger an external event when a predetermined amount of time has expired. The PWM mode can generate Pulse-Width Modulated signals of varying frequency and duty cycle.

**TABLE 24-1: AVAILABLE CCP MODULES**

Device	CCP1	CCP2
PIC16(L)F1764	•	•
PIC16(L)F1765	•	•
PIC16(L)F1768	•	•
PIC16(L)F1769	•	•

**Note 1:** In devices with more than one CCP module, it is very important to pay close attention to the register names used. A number placed after the module acronym is used to distinguish between separate modules. For example, the CCP1CON and CCP2CON control the same operational aspects of two completely different CCP modules.

**2:** Throughout this section, generic references to a CCP module in any of its operating modes may be interpreted as being equally applicable to the CCPx module. Register names, module signals, I/O pins and bit names may use the generic designator, 'x', to indicate the use of a numeral to distinguish a particular module when required.

## 24.1 Capture Mode

The Capture mode function described in this section is available and identical for all CCP modules.

Capture mode makes use of the 16-bit Timer1 resource. When an event occurs on the CCPx input, the 16-bit CCPRxH:CCPRxL register pair captures and stores the 16-bit value of the TMR1H:TMR1L register pair, respectively. An event is defined as one of the following and is configured by the MODE<3:0> bits of the CCPxCON register:

- Every edge (rising or falling)
- Every falling edge
- Every rising edge
- Every 4th rising edge
- Every 16th rising edge

The CCPx capture input signal is configured by the CTS<2:0> bits of the CCPxCAP register with the following options:

- CCPx pin
- Comparator 1 output (C1\_OUT\_sync)
- Comparator 2 output (C2\_OUT\_sync)
- Comparator 3 output (C3\_OUT\_sync)
- Comparator 4 output (C4\_OUT\_sync)
- LC2\_output
- LC3\_output
- Interrupt-On-Change interrupt trigger (IOC\_interrupt)

When a capture is made, the CCPx Interrupt Flag bit, CCPxIF of the PIRx register, is set. The interrupt flag must be cleared in software. If another capture occurs before the value in the CCPRxH:CCPRxL register pair is read, the old captured value is overwritten by the new captured value.

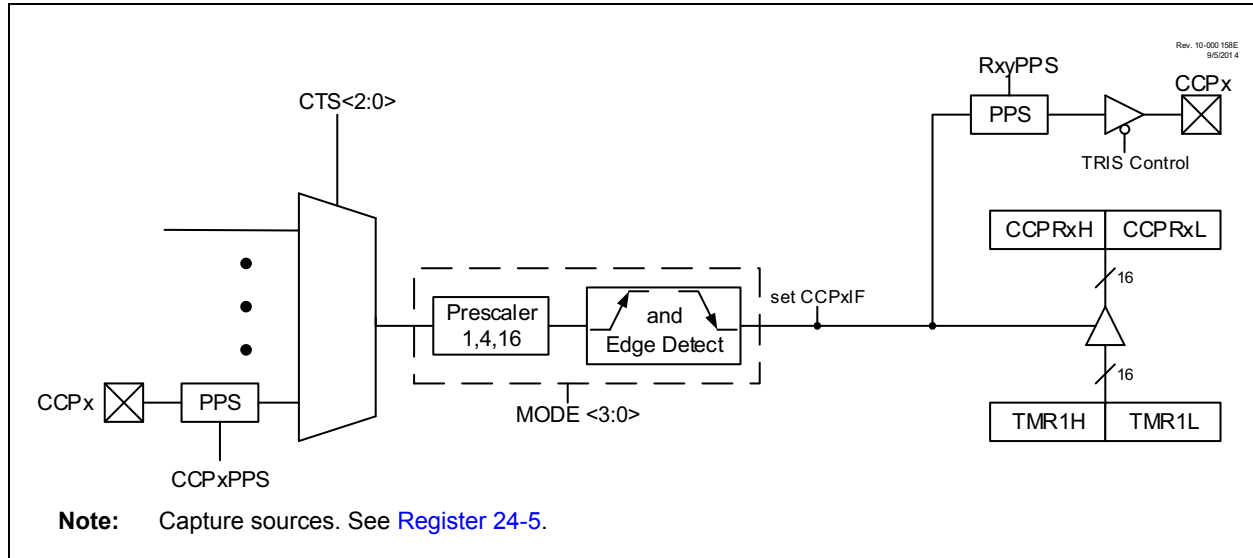
Figure 24-1 shows a simplified diagram of the capture operation.

### 24.1.1 CCP PIN CONFIGURATION

In Capture mode, select the interrupt source using the CTSx bits of the CCPxCAP register. If the CCPx pin is chosen, it should be configured as an input by setting the associated TRISx control bit.

**Note:** If the CCPx pin is configured as an output, a write to the port can cause a capture condition.

**FIGURE 24-1: CAPTURE MODE OPERATION BLOCK DIAGRAM**



## 24.1.2 TIMER1 MODE RESOURCE

Timer1 must be running in Timer mode or Synchronized Counter mode for the CCP module to use the capture feature. In Asynchronous Counter mode, the capture operation may not work.

See [Section 22.0 “Timer1/3/5 Module with Gate Control”](#) for more information on configuring Timer1.

## 24.1.3 SOFTWARE INTERRUPT MODE

When the Capture mode is changed, a false capture interrupt may be generated. The user should keep the CCPxIE interrupt enable bit of the PIRx register clear to avoid false interrupts. Additionally, the user should clear the CCPxIF interrupt flag bit of the PIRx register following any change in operating mode.

**Note:** Clocking Timer1 from the system clock ( $F_{OSC}$ ) should not be used in Capture mode. In order for Capture mode to recognize the trigger event on the CCPx pin, Timer1 must be clocked from the instruction clock ( $F_{OSC}/4$ ) or from an external clock source.

## 24.1.4 CCP PRESCALER

There are four prescaler settings specified by the MODE<3:0> bits of the CCPxCON register. Whenever the CCP module is turned off, or the CCP module is not in Capture mode, the prescaler counter is cleared. Any Reset will clear the prescaler counter.

Switching from one capture prescaler to another does not clear the prescaler and may generate a false interrupt. To avoid this unexpected operation, turn the module off by clearing the EN bit of the CCPxCON register before changing the prescaler.

## 24.1.5 CAPTURE DURING SLEEP

Capture mode depends upon the Timer1 module for proper operation. There are two options for driving the Timer1 module in Capture mode. It can be driven by the instruction clock ( $F_{OSC}/4$ ), or by an external clock source.

When Timer1 is clocked by  $F_{OSC}/4$ , Timer1 will not increment during Sleep. When the device wakes from Sleep, Timer1 will continue from its previous state.

Capture mode will operate during Sleep when Timer1 is clocked by an external clock source.

## 24.1.6 ALTERNATE PIN LOCATIONS

This module incorporates I/O pins that can be moved to other locations with the use of the PPS controls. See [Section 12.0 “Peripheral Pin Select \(PPS\) Module”](#) for more details.

## 24.1.7 CAPTURE OUTPUT

Whenever a capture occurs, the output of the CCP will go high for a period equal to one system clock period ( $1/F_{OSC}$ ). This output is available as an input signal to the following peripherals:

- ADC trigger
- COG
- PRG
- DSM
- CLC
- Op amp override
- Timer2/4/6 Reset
- Any device pins

In addition, the CCP output can be output to any pin with that pin’s PPS control.

## 24.2 Compare Mode

The Compare mode function described in this section is available and identical for all CCP modules.

Compare mode makes use of the 16-bit Timer1 resource. The 16-bit value of the CCPRxH:CCPRxL register pair is constantly compared against the 16-bit value of the TMR1H:TMR1L register pair. When a match occurs, one of the following events can occur:

- Toggle the CCPx output
- Set the CCPx output
- Clear the CCPx output
- Pulse the CCPx output
- Generate a software interrupt
- Auto-conversion trigger

The action on the pin is based on the value of the MODE<3:0> control bits of the CCPxCON register. At the same time, the interrupt flag CCPxIF bit is set.

All Compare modes can generate an interrupt.

Figure 24-2 shows a simplified diagram of the compare operation.

### 24.2.1 AUTO-CONVERSION TRIGGER

When Auto-Conversion Trigger mode is chosen (CCPxM<3:0> = 1011), the CCPx module does the following:

- Resets Timer1
- Starts an ADC conversion if ADC is enabled

The CCPx module does not assert control of the CCPx pin in this mode.

The auto-conversion trigger output of the CCP occurs immediately upon a match between the TMR1H, TMR1L register pair and the CCPRxH, CCPRxL

register pair. The TMR1H, TMR1L register pair is not reset until the next rising edge of the Timer1 clock. The auto-conversion trigger output starts an ADC conversion (if the ADC module is enabled). This allows the CCPRxH, CCPRxL register pair to effectively provide a 16-bit programmable period register for Timer1.

Refer to [Section 16.2.5 “Auto-Conversion Trigger”](#) for more information.

**Note 1:** The auto-conversion trigger from the CCP module does not set interrupt flag bit, TMR1IF of the PIR1 register.

**2:** Removing the match condition by changing the contents of the CCPRxH and CCPRxL register pair, between the clock edge that generates the auto-conversion trigger and the clock edge that generates the Timer1 Reset, will preclude the Reset from occurring.

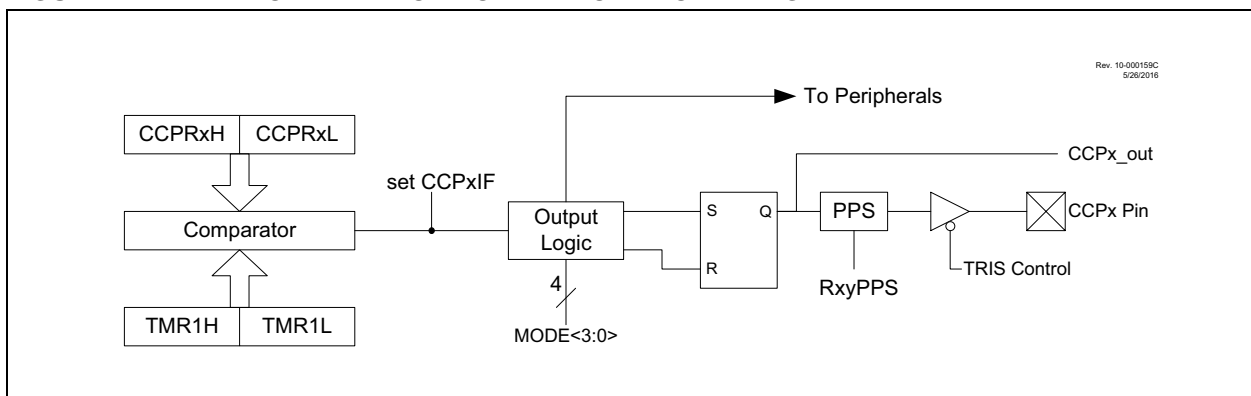
### 24.2.2 CCPx PIN CONFIGURATION

The user must configure the CCPx pin as an output by clearing the associated TRISx bit.

The CCPx pin function can be moved to alternate pins using the PPS controls. See [Section 12.0 “Peripheral Pin Select \(PPS\) Module”](#) for more detail.

**Note:** Clearing the CCPxCON register will force the CCPx compare output latch to the default low level. This is not the PORT I/O data latch.

**FIGURE 24-2: COMPARE MODE OPERATION BLOCK DIAGRAM**



## 24.2.3 TIMER1 MODE RESOURCE

In Compare mode, Timer1 must be running in either Timer mode or Synchronized Counter mode. The compare operation may not work in Asynchronous Counter mode.

See [Section 22.0 “Timer1/3/5 Module with Gate Control”](#) for more information on configuring Timer1.

**Note:** Clocking Timer1 from the system clock (FOSC) should not be used in Compare mode. In order for Compare mode to recognize the trigger event on the CCPx pin, Timer1 must be clocked from the instruction clock (FOSC/4) or from an external clock source.

## 24.2.4 SOFTWARE INTERRUPT MODE

When Generate Software Interrupt mode is chosen (MODE<3:0> = 1010), the CCPx module does not assert control of the CCPx pin (see the CCPxCON register).

## 24.2.5 COMPARE DURING SLEEP

The Compare mode is dependent upon the system clock (FOSC) for proper operation. Since FOSC is shut down during Sleep mode, the Compare mode will not function properly during Sleep.

## 24.2.6 ALTERNATE PIN LOCATIONS

This module incorporates I/O pins that can be moved to other locations with the use of the PPS controls. See [Section 12.0 “Peripheral Pin Select \(PPS\) Module”](#) for more detail.

## 24.2.7 CAPTURE OUTPUT

When in Compare mode, the CCP will provide an output upon the 16-bit value of the CCPRxH:CCPRxL register pair matching the TMR1H:TMR1L register pair. The compare output depends on which Compare mode the CCP is configured as. If the MODEx bits of the CCPxCON register are equal to ‘1011’ or ‘1010’, the CCP module will output high, while TMR1 is equal to the CCPRxH:CCPRxL register pair. This means that the pulse width is determined by the TMR1 prescaler. If the MODEx bits of CCPxCON are equal to ‘0001’ or ‘0010’, the output will toggle upon a match, going from ‘0’ to ‘1’ or vice-versa. If the MODEx bits of CCPxCON are equal to ‘1001’, the output is cleared on a match, and if the MODEx bits are equal to ‘1000’, the output is set on a match. This output is available to the following peripherals:

- ADC trigger
- COG
- PRG
- DSM
- CLC
- Op amp override
- Timer2/4/6 Reset
- Any device pins

## 24.3 PWM Overview

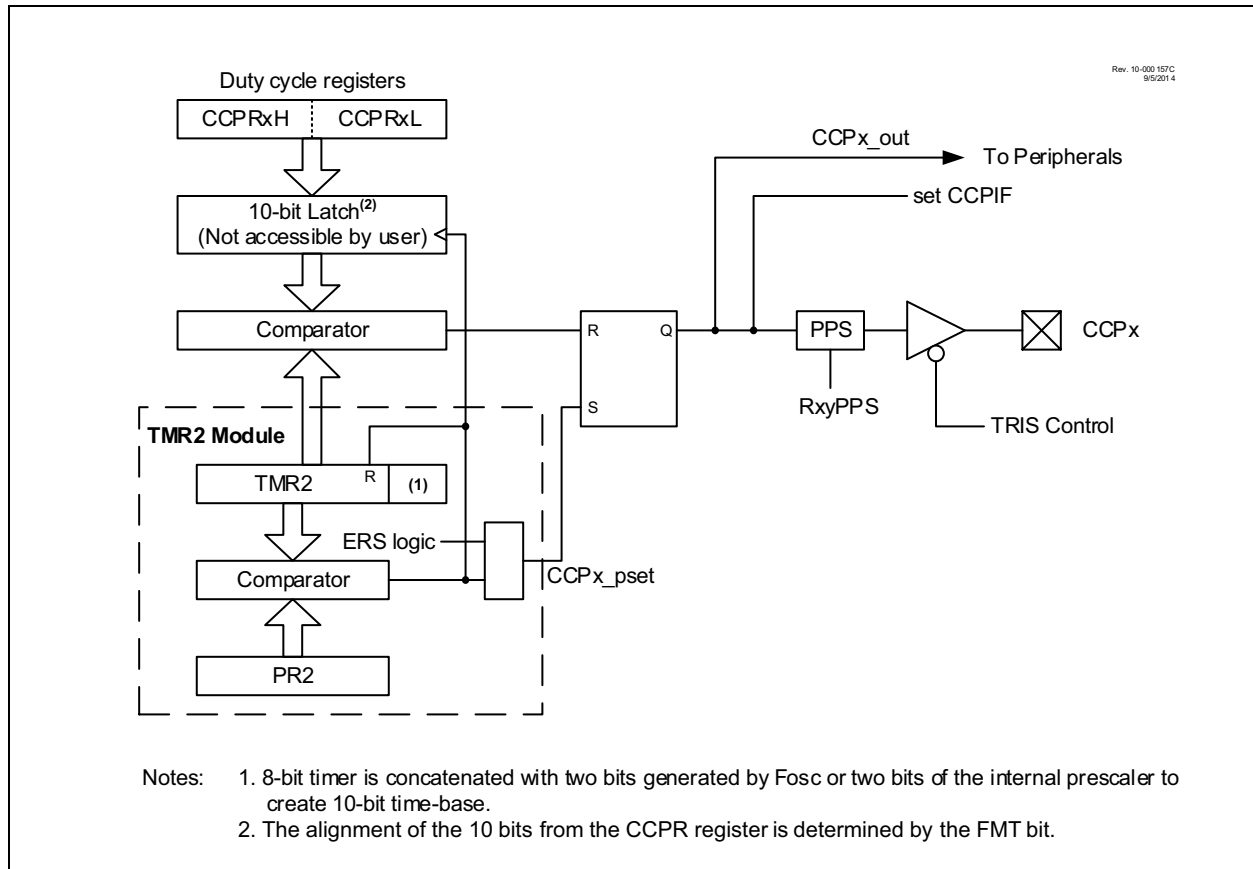
Pulse-Width Modulation (PWM) is a scheme that provides power to a load by switching quickly between fully on and fully off states. The PWM signal resembles a square wave where the high portion of the signal is considered the on state and the low portion of the signal is considered the off state. The high portion, also known as the pulse width, can vary in time and is defined in steps. A larger number of steps applied, which lengthens the pulse width, also supplies more power to the load. Lowering the number of steps applied, which shortens the pulse width, supplies less power. The PWM period is defined as the duration of one complete cycle or the total amount of on and off time combined.

PWM resolution defines the maximum number of steps that can be present in a single PWM period. A higher resolution allows for more precise control of the pulse-width time, and in turn, the power that is applied to the load.

The term duty cycle describes the proportion of the on time to the off time and is expressed in percentages, where 0% is fully off and 100% is fully on. A lower duty cycle corresponds to less power applied and a higher duty cycle corresponds to more power applied.

Figure 24-3 shows a typical waveform of the PWM signal.

**FIGURE 24-3: SIMPLIFIED PWM BLOCK DIAGRAM**



## 24.3.1 STANDARD PWM OPERATION

The standard PWM function described in this section is available and identical for all CCP modules.

The standard PWM mode generates a Pulse-Width Modulation (PWM) signal on the CCPx pin with up to 10 bits of resolution. The period, duty cycle and resolution are controlled by the following registers:

- T2PR/T4PR/T6PR registers
- T2CON/T4CON/T6CON registers
- CCPRxH:CCPRxL register pair

Figure 24-3 shows a simplified block diagram of PWM operation.

**Note 1:** The corresponding TRISx bit must be cleared to enable the PWM output on the CCPx pin.

**2:** Clearing the CCPxCON register will relinquish control of the CCPx pin.

## 24.3.2 SETUP FOR PWM OPERATION

The following steps should be taken when configuring the CCP module for standard PWM operation:

1. Disable the CCPx pin output driver by setting the associated TRISx bit.
2. Select the timer associated with the PWM by setting the CCPTMRS register.
3. Load the associated T2PR/T4PR/T6PR register with the PWM period value.
4. Configure the CCP module for the PWM mode by loading the CCPxCON register with the appropriate values.
5. Load the CCPRxH:CCPRxL register pair with the PWM duty cycle value.
6. Configure and start the timer selected in Step 2:
  - Clear the timer interrupt flag bit of the PIRx register. See Note below.
  - Configure the CKPSx bits of the TxCON register with the timer prescale value.
  - Enable the timer by setting the ON bit of the TxCON register.
7. Enable PWM output pin:
  - Wait until the timer overflows and the timer interrupt bit of the PIRx register is set. See Note below.
  - Enable the CCPx pin output driver by clearing the associated TRISx bit.

**Note:** In order to send a complete duty cycle and period on the first PWM output, the above steps must be included in the setup sequence. If it is not critical to start with a complete PWM signal on the first output, then Step 6 may be ignored.

## 24.4 CCP/PWM Clock Selection

The PIC16(L)F1764/5/8/9 allows each individual CCP and PWM module to select the timer source that controls the module. Each module has an independent selection.

As there are up to three 8-bit timers with auto-reload (Timer2/4/6), the PWM mode on the CCP and PWM modules can use any of these timers.

The CCPTMRS register is used to select which timer is used.

### 24.4.1 USING THE TMR2/4/6 WITH THE CCP MODULE

This device has a new version of the TMR2 module that has many new modes, which allow for greater customization and control of the PWM signals than older parts. Refer to [Section 23.6 “Operation Examples”](#) for examples of PWM signal generation using the different modes of Timer2. The CCP operation requires that the timer used as the PWM time base has the FOSC/4 clock source selected.

### 24.4.2 PWM PERIOD

The PWM period is specified by the T2PR/T4PR/T6PR register of Timer2/4/6. The PWM period can be calculated using the formula of [Equation 24-1](#).

#### EQUATION 24-1: PWM PERIOD

$$PWM\ Period = [(PR2) + 1] \cdot 4 \cdot TOSC \cdot (TMR2\ Prescale\ Value)$$

**Note 1:** TOSC = 1/FOSC.

When TMR2/4/6 is equal to its respective T2PR/T4PR/T6PR register, the following three events occur on the next increment cycle:

- TMR2/4/6 is cleared
- The CCPx pin is set. (Exception: If the PWM duty cycle = 0%, the pin will not be set.)
- The PWM duty cycle is latched from the CCPRxH:CCPRxL pair into the internal 10-bit latch.

**Note:** The Timer postscaler (see [Figure 24-1](#)) is not used in the determination of the PWM frequency.

### 24.4.3 PWM DUTY CYCLE

The PWM duty cycle is specified by writing a 10-bit value to two registers: the CCPRxH:CCPRxL register pair. Where the particular bits go is determined by the FMT bit of the CCPxCON register. If FMT = 0, the two Most Significant bits of the duty cycle value should be written to bits<1:0> of the CCPRxH register and the remaining eight bits to the CCPRxL register. If FMT = 1, the Least Significant two bits of the duty cycle should be written to bits<7:6> of the CCPRxL register and the Most Significant eight bits to the CCPRxH register. This is illustrated in [Figure 24-4](#). These bits can be written at any time. The duty cycle value is not latched into the internal latch until after the period completes (i.e., a match between T2PR/T4PR/T6PR and TMR2/4/6 registers occurs).

[Equation 24-2](#) is used to calculate the PWM pulse width. [Equation 24-3](#) is used to calculate the PWM duty cycle ratio.

#### EQUATION 24-2: PULSE WIDTH

$$Pulse\ Width = CCPRxH:CCPRxL \cdot TOSC \cdot (TMR2\ Prescale\ Value)$$

#### EQUATION 24-3: DUTY CYCLE RATIO

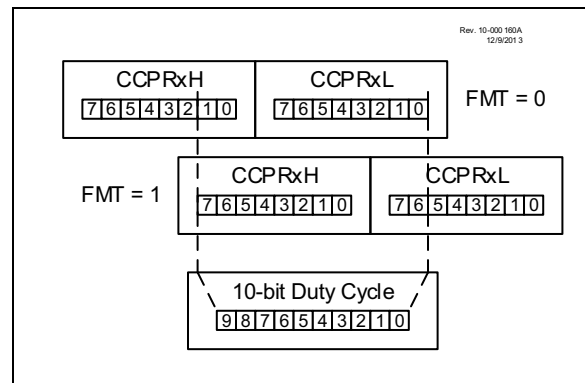
$$Duty\ Cycle\ Ratio = \frac{CCPRxH:CCPRxL}{4(PR_x + 1)}$$

The PWM Duty Cycle registers are double-buffered for glitchless PWM operation.

The 8-bit timer TMR2/4/6 register is concatenated with either the 2-bit internal system clock (FOSC), or two bits of the prescaler, to create the 10-bit time base. The system clock is used if the Timer2/4/6 prescaler is set to 1:1.

When the 10-bit time base matches the internal buffer register, then the CCPx pin is cleared (see [Figure 24-3](#)).

#### FIGURE 24-4: CCPx DUTY CYCLE ALIGNMENT





## 24.4.4 PWM RESOLUTION

The resolution determines the number of available duty cycles for a given period. For example, a 10-bit resolution will result in 1024 discrete duty cycles, whereas an 8-bit resolution will result in 256 discrete duty cycles.

The maximum PWM resolution is 10 bits when T2PR/T4PR/T6PR is 255. The resolution is a function of the T2PR/T4PR/T6PR register value as shown by [Equation 24-4](#).

## EQUATION 24-4: PWM RESOLUTION

$$Resolution = \frac{\log[4(PR2 + 1)]}{\log(2)} \text{ bits}$$

**Note:** If the pulse-width value is greater than the period, the assigned PWM pin(s) will remain unchanged.

**TABLE 24-2: EXAMPLE PWM FREQUENCIES AND RESOLUTIONS (Fosc = 20 MHz)**

PWM Frequency	1.22 kHz	4.88 kHz	19.53 kHz	78.12 kHz	156.3 kHz	208.3 kHz
Timer Prescale	16	4	1	1	1	1
T2PR Value	0xFF	0xFF	0xFF	0x3F	0x1F	0x17
Maximum Resolution (bits)	10	10	10	8	7	6

**TABLE 24-3: EXAMPLE PWM FREQUENCIES AND RESOLUTIONS (Fosc = 8 MHz)**

PWM Frequency	1.22 kHz	4.90 kHz	19.61 kHz	76.92 kHz	153.85 kHz	200.0 kHz
Timer Prescale	16	4	1	1	1	1
T2PR Value	0x65	0x65	0x65	0x19	0x0C	0x09
Maximum Resolution (bits)	8	8	8	6	5	5

## 24.4.5 CHANGES IN SYSTEM CLOCK FREQUENCY

The PWM frequency is derived from the system clock frequency. Any changes in the system clock frequency will result in changes to the PWM frequency. See [Section 5.0 “Oscillator Module \(with Fail-Safe Clock Monitor\)”](#) for additional details.

## 24.4.6 EFFECTS OF RESET

Any Reset will force all ports to Input mode and the CCP registers to their Reset states.

## 24.4.7 PWM OUTPUT

The output of the CCP in PWM mode is the PWM signal generated by the module and described above. This output is available to the following peripherals:

- ADC trigger
- COG
- PRG
- DSM
- CLC
- Op amp override
- Timer2/4/6 Reset
- Any device pins

## 24.5 Register Definitions: CCP Control

### REGISTER 24-1: CCPxCON: CCPx CONTROL REGISTER

R/W-0/0	U-0	R-x	R/W-0/0	R/W-0/0	R/W-0/0	R/W-0/0	R/W-0/0
EN	—	OUT	FMT	MODE<3:0>			
bit 7							bit 0

#### Legend:

R = Readable bit	W = Writable bit	
u = Bit is unchanged	x = Bit is unknown	U = Unimplemented bit, read as '0'
'1' = Bit is set	'0' = Bit is cleared	-n/n = Value at POR and BOR/Value at all other Reset

bit 7	<b>EN:</b> CCPx Module Enable bit 1 = CCPx is enabled 0 = CCPx is disabled
bit 6	<b>Unimplemented:</b> Read as '0'
bit 5	<b>OUT:</b> CCPx Output Data bit (read-only)
bit 4	<b>FMT:</b> CCPW (Pulse-Width) Alignment bit <b>If MODE&lt;3:0&gt; = PWM Mode:</b> 1 = Left-aligned format, CCPRxH<7> is the MSB of the PWM duty cycle 0 = Right-aligned format, CCPRxL<0> is the LSB of the PWM duty cycle
bit 3-0	<b>MODE&lt;3:0&gt;:</b> CCPx Mode Selection bits 11xx = PWM mode  1011 = Compare mode: Pulse output, clear TMR1 1010 = Compare mode: Pulse output (0 - 1 - 0) 1001 = Compare mode: Clear output on compare match; output is set upon selection of this mode 1000 = Compare mode: Set output on compare match; output is set upon selection of this mode  0111 = Capture mode: Every 16th rising edge 0110 = Capture mode: Every 4th rising edge 0101 = Capture mode: Every rising edge 0100 = Capture mode: Every falling edge  0011 = Capture mode: Every rising or falling edge 0010 = Compare mode: Toggle output on match 0001 = Compare mode: Toggle output and clear TMR1 on match 0000 = Capture/Compare/PWM off (resets CCPx module) (reserved for backwards compatibility)

## REGISTER 24-2: CCPTMRS: PWM TIMER SELECTION CONTROL REGISTER

R/W-0/0	R/W-0/0	R/W-0/0	R/W-0/0	R/W-0/0	R/W-0/0	R/W-0/0	R/W-0/0
P4TSEL<1:0> <sup>(1)</sup>		P3TSEL<1:0>		C2TSEL<1:0>		C1TSEL<1:0>	
bit 7						bit 0	

### Legend:

R = Readable bit

W = Writable bit

u = Bit is unchanged

x = Bit is unknown

U = Unimplemented bit, read as '0'

'1' = Bit is set

'0' = Bit is cleared

-n/n = Value at POR and BOR/Value at all other Resets

- bit 7-6      **P4TSEL<1:0>**: PWM4 Timer Selection bits<sup>(1)</sup>  
                  11 = Reserved  
                  10 = PWM4 is based off Timer6 in PWM mode  
                  01 = PWM4 is based off Timer4 in PWM mode  
                  00 = PWM4 is based off Timer2 in PWM mode
- bit 5-4      **P3TSEL<1:0>**: PWM3 Timer Selection bits  
                  11 = Reserved  
                  10 = PWM3 is based off Timer6 in PWM mode  
                  01 = PWM3 is based off Timer4 in PWM mode  
                  00 = PWM3 is based off Timer2 in PWM mode
- bit 3-2      **C2TSEL<1:0>**: CCP2 (PWM2) Timer Selection bits  
                  11 = Reserved  
                  10 = CCP2 is based off Timer6 in PWM mode  
                  01 = CCP2 is based off Timer4 in PWM mode  
                  00 = CCP2 is based off Timer2 in PWM mode
- bit 1-0      **C1TSEL<1:0>**: CCP1 (PWM1) Timer Selection bits  
                  11 = Reserved  
                  10 = CCP1 is based off Timer6 in PWM mode  
                  01 = CCP1 is based off Timer4 in PWM mode  
                  00 = CCP1 is based off Timer2 in PWM mode

## REGISTER 24-3: CCPRxL: CCPx LOW BYTE REGISTER

R/W-0/0	R/W-0/0	R/W-0/0	R/W-0/0	R/W-0/0	R/W-0/0	R/W-0/0	R/W-0/0
CCPR<7:0>							
bit 7							bit 0

### Legend:

R = Readable bit	W = Writable bit	
u = Bit is unchanged	x = Bit is unknown	U = Unimplemented bit, read as '0'
'1' = Bit is set	'0' = Bit is cleared	-n/n = Value at POR and BOR/Value at all other Resets

bit 7-0      MODE<3:0> = Capture Mode:  
**CCPRxL<7:0>**: LSB of captured TMR1 value.  
MODE<3:0> = Compare Mode:  
**CCPRxL<7:0>**: LSB compared to TMR1 value.  
MODE<3:0> = PWM Mode && FMT = 0:  
**CCPRxL<7:0>**: CCPW<7:0> – Pulse-width Least Significant eight bits.  
MODE<3:0> = PWM Mode and FMT = 1:  
**CCPRxL<7:6>**: CCPW<1:0> – Pulse-width Least Significant two bits.  
**CCPRxL<5:0>**: Not used.

## REGISTER 24-4: CCPRxH: CCPx HIGH BYTE REGISTER

R/W-0/0	R/W-0/0	R/W-0/0	R/W-0/0	R/W-0/0	R/W-0/0	R/W-0/0	R/W-0/0
CCPR<15:8>							
bit 7							bit 0

### Legend:

R = Readable bit	W = Writable bit	
u = Bit is unchanged	x = Bit is unknown	U = Unimplemented bit, read as '0'
'1' = Bit is set	'0' = Bit is cleared	-n/n = Value at POR and BOR/Value at all other Resets

bit 7-0      MODE<3:0> = Capture Mode:  
**CCPRxH<7:0>**: MSB of captured TMR1 value.  
MODE<3:0> = Compare Mode:  
**CCPRxH<7:0>**: MSB compared to TMR1 value.  
MODE<3:0> = PWM Mode && FMT = 0:  
**CCPRxH<7:2>**: Not used.  
**CCPRxH<1:0>**: CCPW<9:8> – Pulse-width Most Significant two bits.  
MODE<3:0> = PWM Mode and FMT = 1:  
**CCPRxH<7:0>**: CCPW<9:2> – Pulse-width Most Significant eight bits.

# PIC16(L)F1764/5/8/9

## REGISTER 24-5: CCPxCAP: CCPx CAPTURE INPUT SELECTION REGISTER

U-0	U-0	U-0	U-0	U-0	R/W-0/0	R/W-0/0	R/W-0/0
—	—	—	—	—	CTS<2:0>		
bit 7					bit 0		

### Legend:

R = Readable bit

W = Writable bit

u = Bit is unchanged

x = Bit is unknown

U = Unimplemented bit, read as '0'

'1' = Bit is set

'0' = Bit is cleared

-n/n = Value at POR and BOR/Value at all other Reset

bit 7-3

**Unimplemented:** Read as '0'

bit 2-0

**CTS<2:0>:** Capture Trigger Input Selection bits

111 = IOC\_event

110 = LC3\_output

101 = LC2\_output

100 = C4\_sync\_out<sup>(1)</sup>

011 = C3\_sync\_out<sup>(1)</sup>

010 = C2\_sync\_out

001 = C1\_sync\_out

000 = Pin selected with the CCPxPPS register

**Note 1:** PIC16(L)F1768/9 only. Unimplemented on PIC16(L)F1764/5.

# PIC16(L)F1764/5/8/9

**TABLE 24-4: SUMMARY OF REGISTERS ASSOCIATED WITH STANDARD PWM**

Name	Bit 7	Bit 6	Bit 5	Bit 4	Bit 3	Bit 2	Bit 1	Bit 0	Register on Page
CCPxCAP	—	—	—	—	—	CTS<2:0>			261
CCPxCON	EN	OE	OUT	FMT	MODE<3:0>				258
CCPRxL	Capture/Compare/PWM Register x (LSB)								260
CCPRxH	Capture/Compare/PWM Register x (MSB)								260
CCPTMRS	P4TSEL<1:0>		P3TSEL<1:0>		C2TSEL<1:0>		C1TSEL<1:0>		259
INTCON	GIE	PEIE	TMR0IE	INTE	IOCIE	TMR0IF	INTF	IOCIF	101
PIE1	TMR1GIE	ADIE	RCIE	TXIE	SSP1IE	CCP1IE	TMR2IE	TMR1IE	102
PIE2	OSFIE	C2IE	C1IE	—	BCL1IE	C4IE <sup>(1)</sup>	C3IE <sup>(1)</sup>	CCP2IE <sup>(1)</sup>	103
T2PR	Timer2 Period Register								229*
T2CON	ON	CKPS<2:0>			OUTPS<3:0>				246
TMR2	Timer2 Module Register								229
T4PR	Timer4 Period Register								229*
T4CON	ON	CKPS<2:0>			OUTPS<3:0>				246
TMR4	Timer4 Module Register								229
T6PR	Timer6 Period Register								229*
T6CON	ON	CKPS<2:0>			OUTPS<3:0>				246
TMR6	Timer6 Module Register								229

**Legend:** — = unimplemented location, read as '0'. Shaded cells are not used by the PWM.

\* Page provides register information.

**Note 1:** PIC16(L)F1768/9 only.

## 25.0 10-BIT PULSE-WIDTH MODULATION (PWM) MODULE

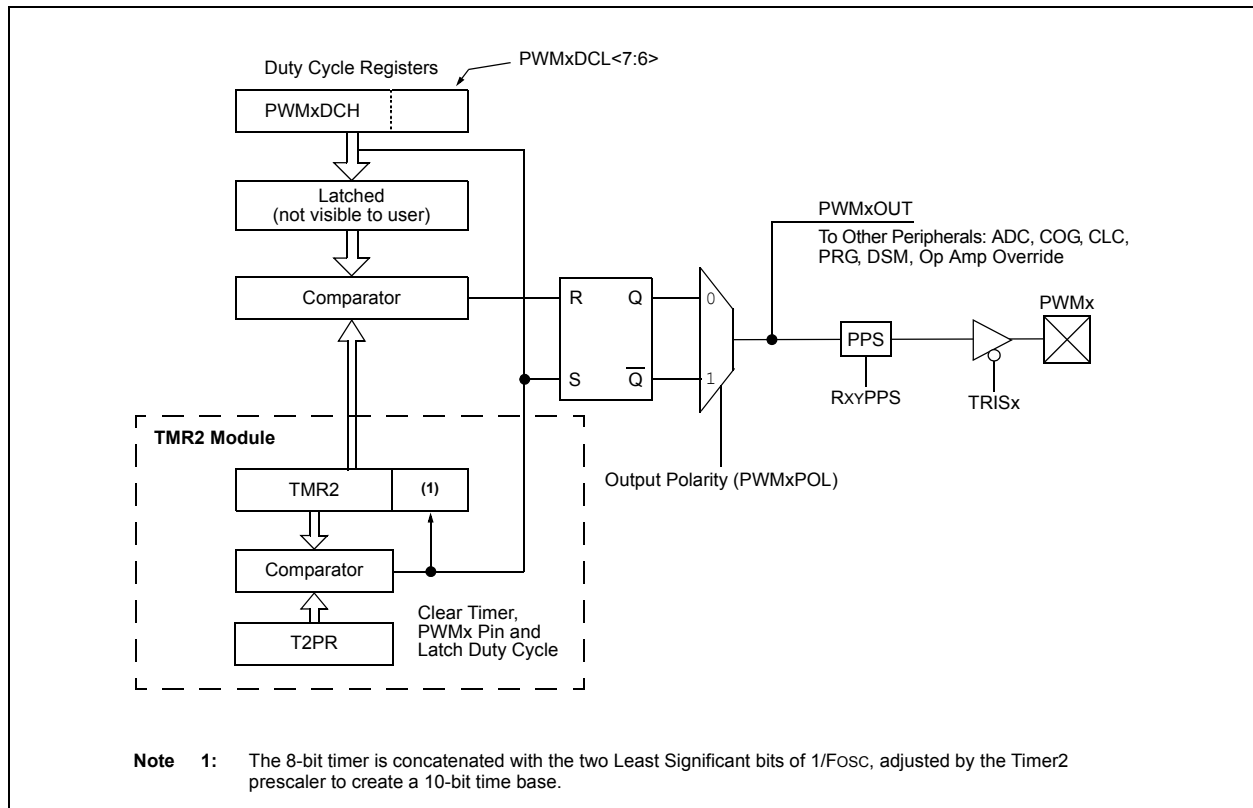
The 10-bit PWM module generates a Pulse-Width Modulated signal determined by the duty cycle, period and resolution that are configured by the following registers:

- T2PR
- T2CON
- PWMxDCH
- PWMxDCL
- PWMxCON

Figure 25-1 shows a simplified block diagram of PWM operation.

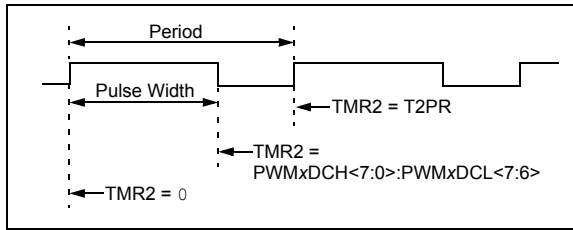
Figure 25-2 shows a typical waveform of the PWM signal.

**FIGURE 25-1: SIMPLIFIED PWM BLOCK DIAGRAM**



For a step-by-step procedure on how to set up this module for PWM operation, refer to [Section 25.10.1 “Setup for PWM Operation Using PWMx Output Pins”](#).

**FIGURE 25-2: PWM OUTPUT**



## 25.1 PWMx Pin Configuration

All PWM outputs are multiplexed with the PORT data latch. The user must configure the pins as outputs by clearing the associated TRISx bits.

## 25.2 Fundamental Operation

The PWM module produces a 10-bit resolution output. Timer2 and T2PR set the period of the PWM. The PWMxDCL and PWMxDCH registers configure the duty cycle. The period is common to all PWM modules, whereas the duty cycle is independently controlled.

**Note:** The Timer2 postscaler is not used in the determination of the PWM frequency. The postscaler could be used to have a servo update rate at a different frequency than the PWM output.

All PWM outputs associated with Timer2 are set when TMR2 is cleared. Each PWMx is cleared when TMR2 is equal to the value specified in the corresponding PWMxDCH (8 MSBs) and PWMxDCL<7:6> (2 LSbs) registers. When the value is greater than or equal to T2PR, the PWM output is never cleared (100% duty cycle).

**Note:** The PWMxDCH and PWMxDCL registers are double-buffered. The buffers are updated when Timer2 matches T2PR. Care should be taken to update both registers before the timer match occurs.

## 25.3 PWM Output Polarity

The output polarity is inverted by setting the PWMxPOL bit of the PWMxCON register.

## 25.4 PWM Period

The PWM period is specified by the T2PR register of Timer2. The PWM period can be calculated using the formula of [Equation 25-1](#).

### EQUATION 25-1: PWM PERIOD

$$PWM\ Period = [T2PR + 1] \cdot 4 \cdot TOSC \cdot (TMR2\ Prescale\ Value)$$

**Note:**  $TOSC = 1/FOSC$ .

When TMR2 is equal to T2PR, the following three events occur on the next increment cycle:

- TMR2 is cleared
- The PWM output is active. (Exception: When the PWM duty cycle = 0%, the PWM output will remain inactive.)
- The PWMxDCH and PWMxDCL register values are latched into the buffers.

**Note:** The Timer2 postscaler has no effect on the PWM operation.

## 25.5 PWM Duty Cycle

The PWM duty cycle is specified by writing a 10-bit value to the PWMxDCH and PWMxDCL register pair. The PWMxDCH register contains the eight MSBs and the PWMxDCL<7:6>, the two LSbs. The PWMxDCH and PWMxDCL registers can be written to at any time.

[Equation 25-2](#) is used to calculate the PWM pulse width.

[Equation 25-3](#) is used to calculate the PWM duty cycle ratio.

### EQUATION 25-2: PULSE WIDTH

$$Pulse\ Width = (PWMxDCH:PWMxDCL<7:6>) \cdot TOSC \cdot (TMR2\ Prescale\ Value)$$

**Note:**  $TOSC = 1/FOSC$ .

### EQUATION 25-3: DUTY CYCLE RATIO

$$Duty\ Cycle\ Ratio = \frac{(PWMxDCH:PWMxDCL<7:6>)}{4(T2PR + 1)}$$

The 8-bit timer TMR2 register is concatenated with the two Least Significant bits of  $1/FOSC$ , adjusted by the Timer2 prescaler to create the 10-bit time base. The system clock is used if the Timer2 prescaler is set to 1:1.

## 25.6 PWM Resolution

The resolution determines the number of available duty cycles for a given period. For example, a 10-bit resolution will result in 1024 discrete duty cycles, whereas an 8-bit resolution will result in 256 discrete duty cycles.



The maximum PWM resolution is ten bits when T2PR is 255. The resolution is a function of the T2PR register value as shown by [Equation 25-4](#).

**Note:** If the pulse-width value is greater than the period the assigned PWM pin(s) will remain unchanged.

## EQUATION 25-4: PWM RESOLUTION

$$Resolution = \frac{\log[4(T2PR + 1)]}{\log(2)} \text{ bits}$$

**TABLE 25-1: EXAMPLE PWM FREQUENCIES AND RESOLUTIONS (Fosc = 20 MHz)**

PWM Frequency	0.31 kHz	4.88 kHz	19.53 kHz	78.12 kHz	156.3 kHz	208.3 kHz
Timer Prescale	64	4	1	1	1	1
T2PR Value	0xFF	0xFF	0xFF	0x3F	0x1F	0x17
Maximum Resolution (bits)	10	10	10	8	7	6.6

**TABLE 25-2: EXAMPLE PWM FREQUENCIES AND RESOLUTIONS (Fosc = 8 MHz)**

PWM Frequency	0.31 kHz	4.90 kHz	19.61 kHz	76.92 kHz	153.85 kHz	200.0 kHz
Timer Prescale	64	4	1	1	1	1
T2PR Value	0x65	0x65	0x65	0x19	0x0C	0x09
Maximum Resolution (bits)	8	8	8	6	5	5

## 25.7 Operation in Sleep Mode

In Sleep mode, the TMR2 register will not increment and the state of the module will not change. If the PWMx pin is driving a value, it will continue to drive that value. When the device wakes up, TMR2 will continue from its previous state.

## 25.8 Changes in System Clock Frequency

The PWM frequency is derived from the system clock frequency (Fosc). Any changes in the system clock frequency will result in changes to the PWM frequency. Refer to [Section 5.0 “Oscillator Module \(with Fail-Safe Clock Monitor\)”](#) for additional details.

## 25.9 Effects of Reset

Any Reset will force all ports to Input mode and the PWM registers to their Reset states.

## 25.10 Set-up Procedures

### 25.10.1 SETUP FOR PWM OPERATION USING PWMx OUTPUT PINS

The following steps should be taken when configuring the module for PWM operation using the PWMx output pins:

1. Disable the PWMx pin output driver(s) by setting the associated TRISx bit(s).
2. Clear the PWMxCON register.
3. Load the T2PR register with the PWM period value.
4. Load the PWMxDCH register and bits<7:6> of the PWMxDCL register with the PWM duty cycle value.
5. Configure and start Timer2:
  - Clear the TMR2IF interrupt flag bit of the PIR1 register. See Note below.
  - Configure the CKPSx bits of the T2CON register with the Timer2 prescale value.
  - Enable Timer2 by setting the ON bit of the T2CON register.
6. Enable the PWM output pin and wait until Timer2 overflows. TMR2IF bit of the PIR1 register is set. See Note below.
7. Enable the PWMx pin output driver(s) by clearing the associated TRISx bit(s) and setting the desired pin PPS control bits.
8. Configure the PWM module by loading the PWMxCON register with the appropriate values.

**Note 1:** In order to send a complete duty cycle and period on the first PWM output, the above steps must be followed in the order given. If it is not critical to start with a complete PWM signal, then move Step 8 to replace Step 4.

**2:** For operation with other peripherals only, disable PWMx pin outputs.

### 25.10.2 SETUP FOR PWM OPERATION TO OTHER DEVICE PERIPHERALS

The following steps should be taken when configuring the module for PWM operation to be used by other device peripherals:

1. Disable the PWMx pin output driver(s) by setting the associated TRISx bit(s).
2. Clear the PWMxCON register.
3. Load the T2PR register with the PWM period value.
4. Load the PWMxDCH register and bits<7:6> of the PWMxDCL register with the PWM duty cycle value.
5. Configure and start Timer2:
  - Clear the TMR2IF interrupt flag bit of the PIR1 register. See Note below.
  - Configure the CKPSx bits of the T2CON register with the Timer2 prescale value.
  - Enable Timer2 by setting the ON bit of the T2CON register.
6. Enable PWM output pin:
  - Wait until Timer2 overflows, TMR2IF bit of the PIR1 register is set. See Note below.
7. Configure the PWM module by loading the PWMxCON register with the appropriate values.

**Note:** In order to send a complete duty cycle and period on the first PWM output, the above steps must be included in the setup sequence. If it is not critical to start with a complete PWM signal on the first output, then Step 6 may be ignored.

## 25.11 Register Definitions: 10-Bit PWM Control

Long bit name prefixes for the PWM peripherals are shown in [Table 25-3](#). Refer to [Section 1.1.2.2 “Long Bit Names”](#) for more information.

**TABLE 25-3: BIT NAME PREFIXES**

Peripheral	Bit Name Prefix
PWM3	PWM3
PWM4 <sup>(1)</sup>	PWM4

**Note 1:** PIC16(L)F1768/9 devices only.

### REGISTER 25-1: PWMxCON: PWMx CONTROL REGISTER

R/W-0/0	U-0	R-0/0	R/W-0/0	U-0	U-0	U-0	U-0
EN	—	OUT	POL	—	—	—	—
bit 7							bit 0

**Legend:**

R = Readable bit	W = Writable bit	
u = Bit is unchanged	x = Bit is unknown	U = Unimplemented bit, read as '0'
'1' = Bit is set	'0' = Bit is cleared	-n/n = Value at POR and BOR/Value at all other Resets

- bit 7      **EN:** PWMx Module Enable bit  
1 = PWMx module is enabled  
0 = PWMx module is disabled
- bit 6      **Unimplemented:** Read as '0'
- bit 5      **OUT:** PWMx Module Output Level When Read bit
- bit 4      **POL:** PWMx Output Polarity Select bit  
1 = PWMx output is active-low  
0 = PWMx output is active-high
- bit 3-0    **Unimplemented:** Read as '0'

# PIC16(L)F1764/5/8/9

**REGISTER 25-2: PWMxDCH: PWMx DUTY CYCLE REGISTER HIGH BITS**

R/W-x/u	R/W-x/u	R/W-x/u	R/W-x/u	R/W-x/u	R/W-x/u	R/W-x/u	R/W-x/u
DC<9:2>							
bit 7							bit 0

**Legend:**

R = Readable bit                      W = Writable bit  
u = Bit is unchanged                  x = Bit is unknown                  U = Unimplemented bit, read as '0'  
'1' = Bit is set                          '0' = Bit is cleared                  -n/n = Value at POR and BOR/Value at all other Resets

bit 7-0                  **DC<9:2>**: PWM Duty Cycle Most Significant bits  
These bits are the MSBs of the PWM duty cycle. The two LSBs are found in the PWMxDCL register.

**REGISTER 25-3: PWMxDCL: PWMx DUTY CYCLE REGISTER LOW BITS**

R/W-x/u	R/W-x/u	U-0	U-0	U-0	U-0	U-0	U-0
DC<1:0>		—	—	—	—	—	—
bit 7							bit 0

**Legend:**

R = Readable bit                      W = Writable bit  
u = Bit is unchanged                  x = Bit is unknown                  U = Unimplemented bit, read as '0'  
'1' = Bit is set                          '0' = Bit is cleared                  -n/n = Value at POR and BOR/Value at all other Resets

bit 7-6                  **DC<1:0>**: PWM Duty Cycle Least Significant bits  
These bits are the LSBs of the PWM duty cycle. The MSBs are found in the PWMxDCH register.

bit 5-0                  **Unimplemented**: Read as '0'

**TABLE 25-4: SUMMARY OF REGISTERS ASSOCIATED WITH 10-BIT PWM**

Name	Bit 7	Bit 6	Bit 5	Bit 4	Bit 3	Bit 2	Bit 1	Bit 0	Register on Page
CCPTMRS	P4TSEL<1:0>		P3TSEL<1:0>		C2TSEL<1:0> <sup>(1)</sup>		C1TSEL<1:0>		264
PWMxCON	EN	—	OUT	POL	MODE<1:0>		—	—	267
PWMxDCH	DC<9:2>								268
PWMxDCL	DC<1:0>		—	—	—	—	—	—	268
RxyPPS	—	—	—	RxyPPS<4:0>					156
TxCON	ON	CKPS<2:0>			OUTPS<3:0>				246
TxCLKCON	—	—	—	—	CS<3:0>				245
TxPR	TMRx Period Register								229
TRISA	—	—	TRISA<5:4>		— <sup>(1)</sup>	TRISA<2:0>			138
TRISB <sup>(2)</sup>	TRISB<7:4>								144
TRISC	TRISC7 <sup>(2)</sup>	TRISC6 <sup>(2)</sup>	TRISC5	TRISC4	TRISC3	TRISC2	TRISC1	TRISC0	149

**Legend:** — = Unimplemented location, read as '0'. Shaded cells are not used by the PWM.

**Note 1:** Unimplemented, read as '1'.

**2:** PIC16(L)F1768/9 only.

## 26.0 16-BIT PULSE-WIDTH MODULATION (PWM) MODULE

The Pulse-Width Modulation (PWM) module generates a Pulse-Width Modulated signal determined by the phase, duty cycle, period and offset event counts that are contained in the following registers:

- PWMxPH registers
- PWMxDC registers
- PWMxPR registers
- PWMxOF registers

Figure 26-1 shows a simplified block diagram of the PWM operation.

Each PWM module has four modes of operation:

- Standard
- Set On Match
- Toggle On Match
- Center-Aligned

For a more detailed description of each PWM mode, refer to Section 26.2 “PWM Modes”.

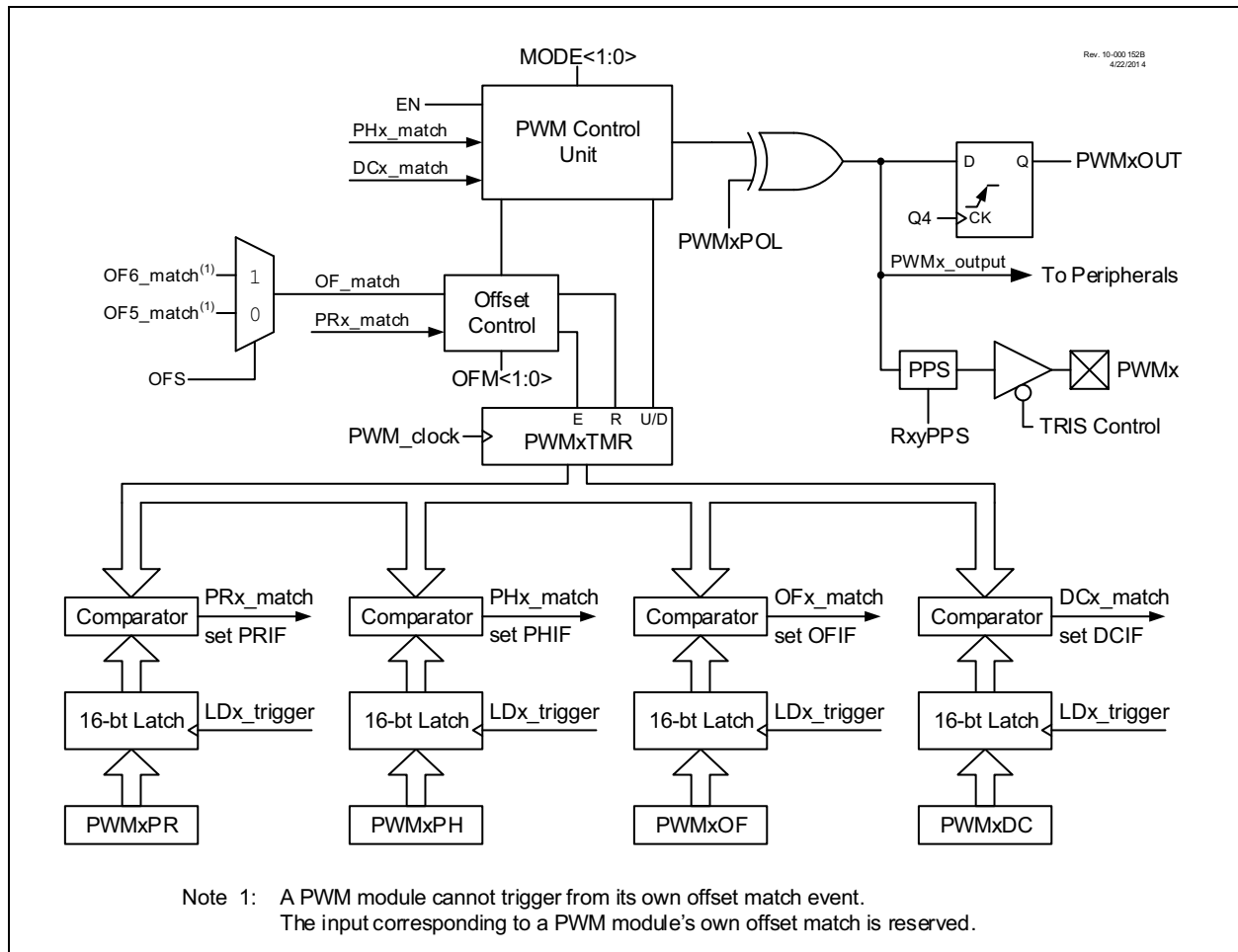
Each PWM module has four Offset modes:

- Independent Run
- Slave Run with Synchronous Start
- One-Shot Slave with Synchronous Start
- Continuous Run Slave with Synchronous Start and Timer Reset

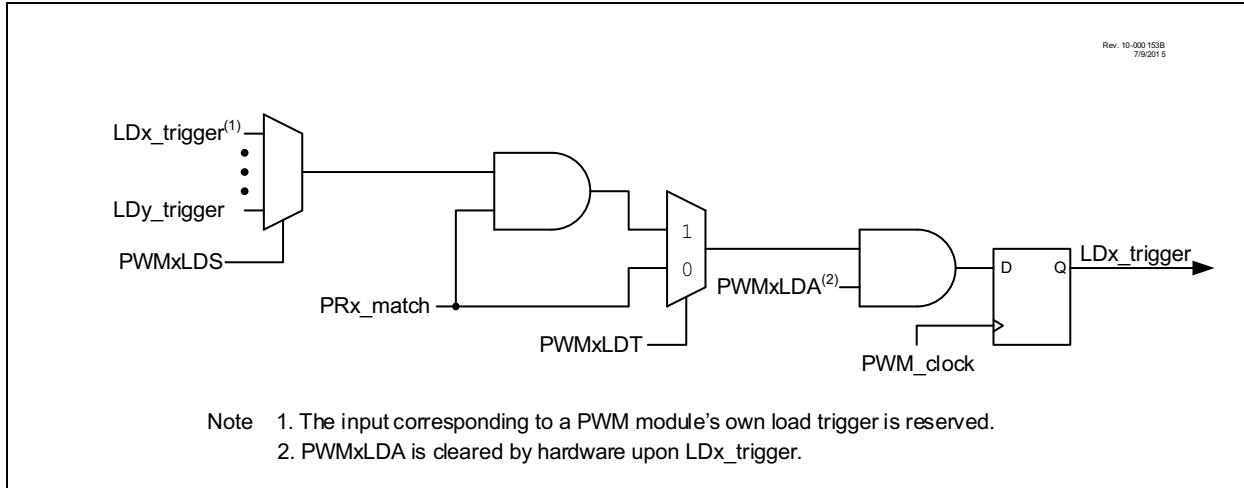
Using the Offset modes, each PWM module can offset its waveform relative to any other PWM module in the same device. For a more detailed description of the Offset modes, refer to Section 26.3 “Offset Modes”.

Every PWM module has a configurable reload operation to ensure all event count buffers change at the end of a period, thereby avoiding signal glitches. Figure 26-2 shows a simplified block diagram of the reload operation. For a more detailed description of the reload operation, refer to Section 26.4 “Reload Operation”.

**FIGURE 26-1: 16-BIT PWMx BLOCK DIAGRAM**



**FIGURE 26-2: LOAD TRIGGER BLOCK DIAGRAM**



## 26.1 Fundamental Operation

The PWM module produces a 16-bit resolution Pulse-Width Modulated output.

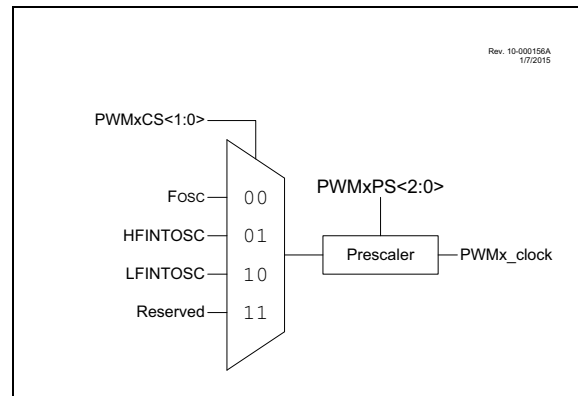
Each PWM module has an independent timer driven by a selection of clock sources determined by the PWMxCLKCON register (Register 26-4). The timer value is compared to Event Count registers to generate the various events of a the PWM waveform, such as the period and duty cycle. For a block diagram describing the clock sources, refer to Figure 26-3.

Each PWM module can be enabled individually using the EN bit of the PWMxCON register, or several PWM modules can be enabled simultaneously using the MPWMxEN bits of the PWMEN register.

The current state of the PWM output can be read using the OUT bit of the PWMxCON register. In some modes, this bit can be set and cleared by software, giving additional software control over the PWM waveform. This bit is synchronized to Fosc/4 and therefore, does not change in real time with respect to the PWM\_clock.

**Note:** If PWM\_clock > Fosc/4, the OUT bit may not accurately represent the output state of the PWM.

**FIGURE 26-3: PWMx CLOCK SOURCE BLOCK DIAGRAM**



### 26.1.1 PWMx PIN CONFIGURATION

This device uses the PPS control circuitry to route peripherals to any device I/O pin. Select the desired pin, or pins, for PWM output with the device pin, using the RxyPPS control register (Register 12-2).

All PWM outputs are multiplexed with the PORT data latch, so the pins must also be configured as outputs by clearing the associated PORT TRISx bits.

The slew rate feature may be configured to optimize the rate to be used in conjunction with the PWM\_outputs. High-speed output switching is attained by clearing the associated PORT SLRCONx bits.

The PWM outputs can be configured to be open-drain outputs by setting the associated PORT ODCONx bits.

### 26.1.2 PWMx Output Polarity

The output polarity is inverted by setting the POL bit of the PWMxCON register. The polarity control affects the PWM output even when the module is not enabled.

## 26.2 PWM Modes

PWM modes are selected with the MODE<1:0> bits of the PWMxCON register ([Register 26-1](#)).

In all PWM modes, an offset match event can also be used to synchronize the PWMxTMR in three Offset modes. See [Section 26.3 “Offset Modes”](#) for more information.

### 26.2.1 STANDARD MODE

The Standard mode (MODE<1:0> = 00) selects a single-phase PWM output. The PWM output in this mode is determined by when the period, duty cycle and phase counts match the PWMxTMR value. The start of the duty cycle occurs on the phase match and the end of the duty cycle occurs on the duty cycle match. The period match resets the timer. The offset match can also be used to synchronize the PWMxTMR in the Offset modes. See [Section 26.3 “Offset Modes”](#) for more information.

[Equation 26-1](#) is used to calculate the PWM period in Standard mode.

[Equation 26-2](#) is used to calculate the PWM duty cycle ratio in Standard mode.

#### EQUATION 26-1: PWM PERIOD IN STANDARD MODE

$$Period = \frac{(PWMxPR + 1) \cdot Prescale}{PWM\_clock}$$

#### EQUATION 26-2: PWM DUTY CYCLE IN STANDARD MODE

$$Duty\ Cycle = \frac{(PWMxDC - PWMxPH)}{PWMxPR + 1}$$

A detailed timing diagram for Standard mode is shown in [Figure 26-4](#).

### 26.2.2 SET ON MATCH MODE

The Set On Match mode (MODE<1:0> = 01) generates an active output when the phase count matches the PWMxTMR value. The output stays active until the OUT bit of the PWMxCON register is cleared or the PWM module is disabled. The duty cycle count has no effect in this mode. The period count only determines the maximum PWMxTMR value above which no phase matches can occur.

The PWMxOUT bit can be used to set or clear the output of the PWM in this mode. Writes to this bit will take place on the next rising edge of the PWM\_clock after the bit is written.

A detailed timing diagram for Set On Match mode is shown in [Figure 26-5](#).

### 26.2.3 TOGGLE ON MATCH MODE

The Toggle On Match mode (MODE<1:0> = 10) generates a 50% duty cycle PWM with a period twice as long as that computed for the Standard PWM mode. Duty cycle count has no effect in this mode. The phase count determines how many PWMxTMR periods, after a period event, the output will toggle.

Writes to the OUT bit of the PWMxCON register will have no effect in this mode.

A detailed timing diagram for Toggle On Match mode is shown in [Figure 26-6](#).

### 26.2.4 CENTER-ALIGNED MODE

The Center-Aligned mode (MODE<1:0> = 11) generates a PWM waveform that is centered in the period. In this mode, the period is two times the PWMxPR count. The PWMxTMR counts up to the period value, then counts back down to 0. The duty cycle count determines both the start and end of the active PWM output. The start of the duty cycle occurs at the match event when PWMxTMR is incrementing, and the duty cycle ends at the match event when PWMxTMR is decrementing. The incrementing match value is the period count minus the duty cycle count. The decrementing match value is the incrementing match value plus 1.

[Equation 26-3](#) is used to calculate the PWM period in Center-Aligned mode.

#### EQUATION 26-3: PWM PERIOD IN CENTER-ALIGNED MODE

$$Period = \frac{(PWMxPR + 1) \cdot 2 \cdot Prescale}{PWM\_clock}$$

[Equation 26-4](#) is used to calculate the PWM duty cycle ratio in Center-Aligned mode

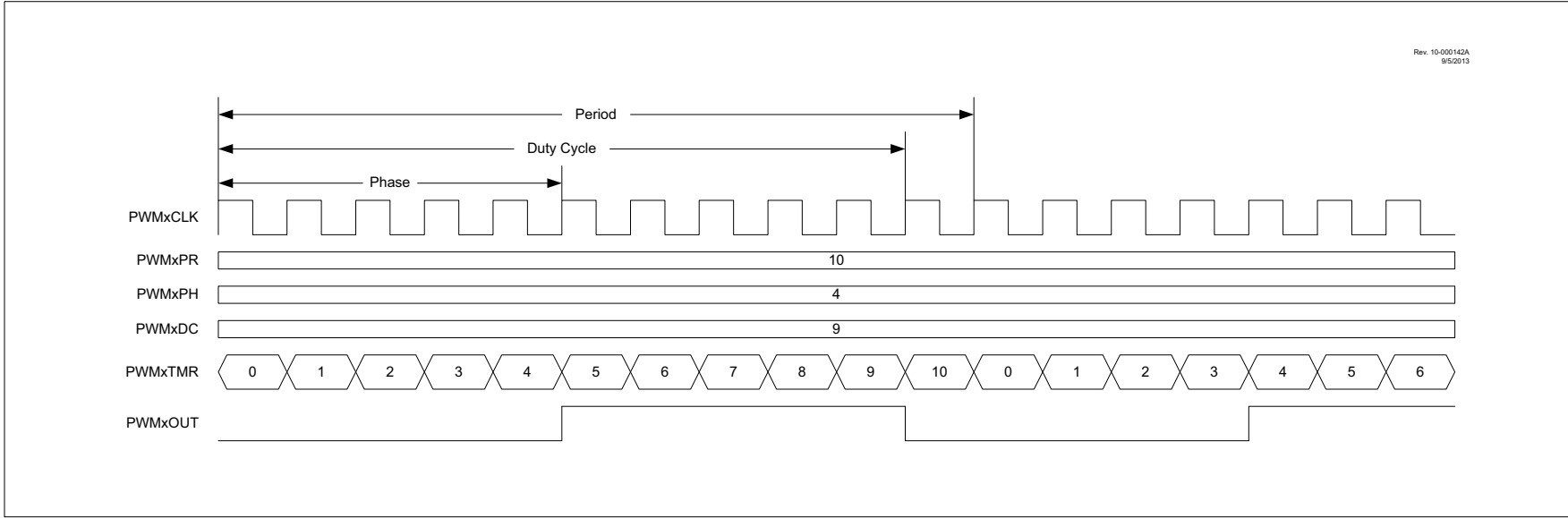
#### EQUATION 26-4: PWM DUTY CYCLE IN CENTER-ALIGNED MODE

$$Duty\ Cycle = \frac{PWMxDC \cdot 2}{(PWMxPR + 1) \cdot 2}$$

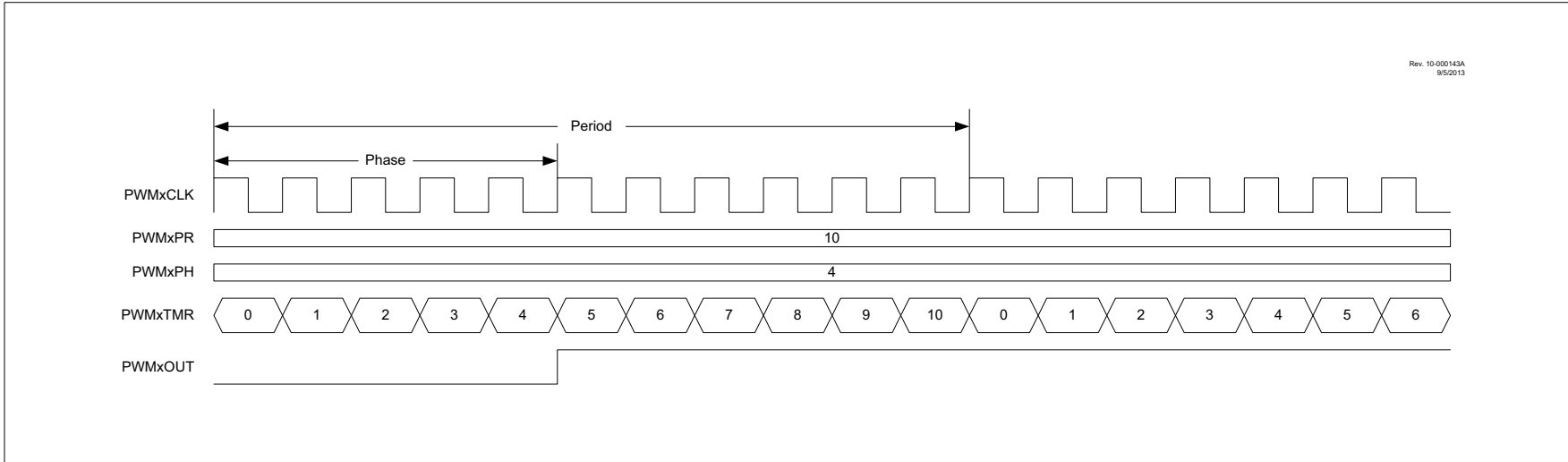
Writes to PWMxOUT will have no effect in this mode.

A detailed timing diagram for Center-Aligned mode is shown in [Figure 26-7](#).

**FIGURE 26-4: STANDARD PWMx MODE TIMING DIAGRAM**

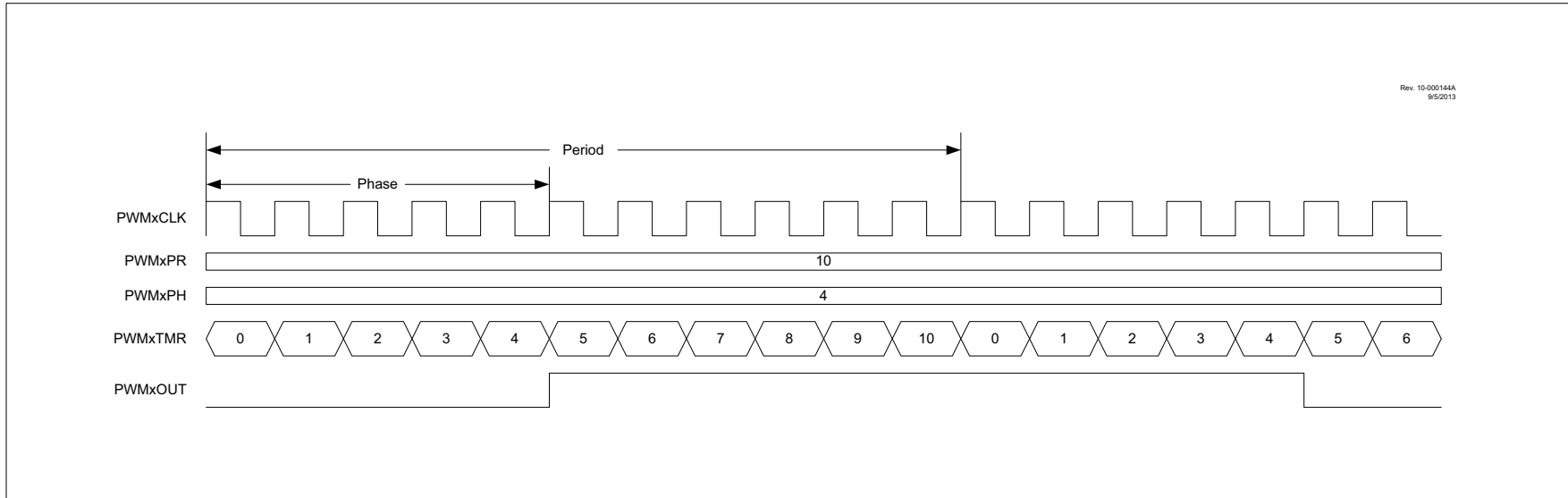


**FIGURE 26-5: SET ON MATCH PWMx MODE TIMING DIAGRAM**

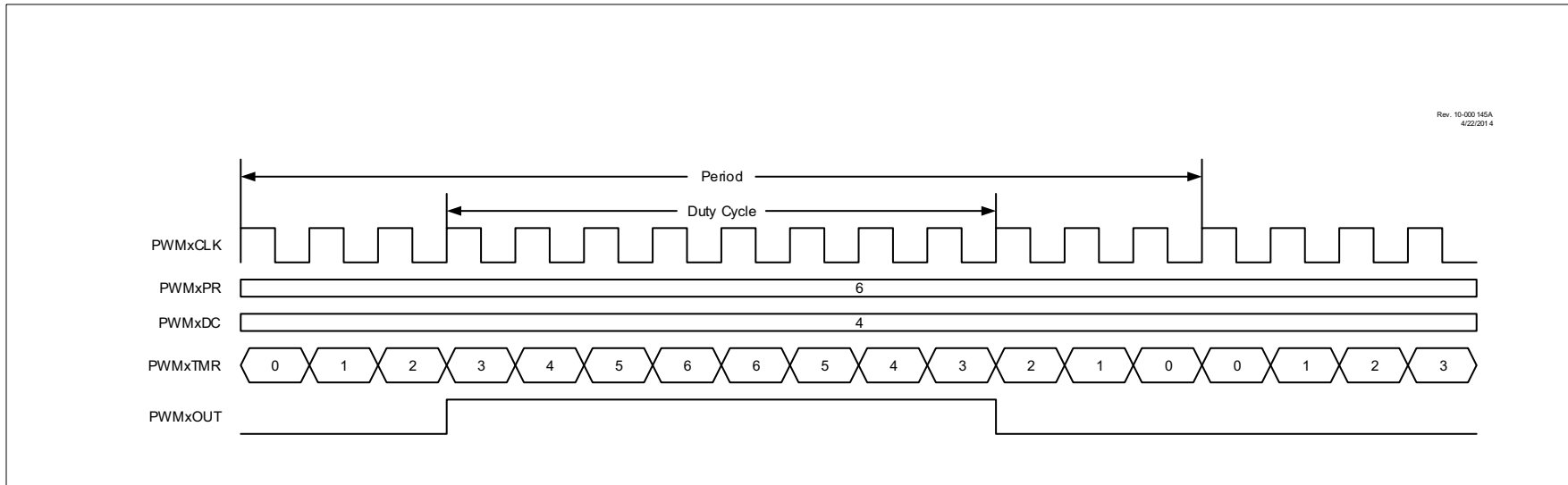




**FIGURE 26-6: TOGGLE ON MATCH PWMx MODE TIMING DIAGRAM**



**FIGURE 26-7: CENTER-ALIGNED PWMx MODE TIMING DIAGRAM**



## 26.3 Offset Modes

The Offset modes provide the means to adjust the waveform of a slave PWM module relative to the waveform of a master PWM module in the same device.

### 26.3.1 INDEPENDENT RUN MODE

In Independent Run mode ( $OFM<1:0> = 00$ ), the PWM module is unaffected by the other PWM modules in the device. The PWMxTMR associated with the PWM module in this mode starts counting as soon as the EN bit associated with this PWM module is set, and continues counting until the EN bit is cleared. Period events reset the PWMxTMR to zero, after which, the timer continues to count.

A detailed timing diagram of this mode used with Standard PWM mode is shown in [Figure 26-8](#).

### 26.3.2 SLAVE RUN MODE WITH SYNC START

In Slave Run mode with Sync Start ( $OFM<1:0> = 01$ ), the slave PWMxTMR waits for the master's OF\_match event. When this event occurs, if the EN bit is set, the PWMxTMR begins counting and continues to count until software clears the EN bit. Slave period events reset the PWMxTMR to zero, after which, the timer continues to count.

A detailed timing diagram of this mode used with Standard PWM mode is shown in [Figure 26-9](#).

### 26.3.3 ONE-SHOT SLAVE MODE WITH SYNC START

In One-Shot Slave mode with Synchronous Start ( $OFM<1:0> = 10$ ), the slave PWMxTMR waits until the master's OF\_match event. The timer then begins counting, starting from the value that is already in the timer, and continues to count until the period match event. When the period event occurs, the timer resets to zero and stops counting. The timer then waits until the next master OF\_match event, after which, it begins counting again to repeat the cycle. An OF\_match event that occurs before the slave PWM has completed the triggered period will be ignored. A slave period that is greater than the master period, but less than twice the master period, will result in a slave output every other master period.

**Note:** During the time the slave timers are resetting to zero, if another offset match event is received, it is possible that the slave PWM would not recognize this match event and the slave timers would fail to begin counting again. This would result in missing duty cycles in the output of the slave PWM. To prevent this from happening, avoid using the same period for both the master and slave PWMs.

A detailed timing diagram of this mode used with Standard PWM mode is shown in [Figure 26-10](#).

### 26.3.4 CONTINUOUS RUN SLAVE MODE WITH SYNC START AND TIMER RESET

In Continuous Run Slave mode with Synchronous Start and Timer Reset ( $OFM<1:0> = 11$ ), the slave PWMxTMR is inhibited from counting after the slave PWM enable is set. The first master OF\_match event starts the slave PWMxTMR. Subsequent master OF\_match events reset the slave PWMxTMR timer value back to 1, after which, the slave PWMxTMR continues to count. The next master OF\_match event resets the slave PWMxTMR back to 1 to repeat the cycle. Slave period events that occur before the master's OF\_match event will reset the slave PWMxTMR to zero, after which, the timer will continue to count. Slaves operating in this mode must have a PWMxPH register pair value equal to, or greater than, 1; otherwise, the phase match event will not occur precluding the start of the PWM output duty cycle.

The offset timing will persist if both the master and slave PWMxPR values are the same and the Slave Offset mode is changed to Independent Run mode while the PWM module is operating.

A detailed timing diagram of this mode used in Standard PWM mode is shown in [Figure 26-11](#).

**Note:** Unexpected results will occur if the slave PWM\_clock is a higher frequency than the master PWM\_clock.

### 26.3.5 OFFSET MATCH IN CENTER-ALIGNED MODE

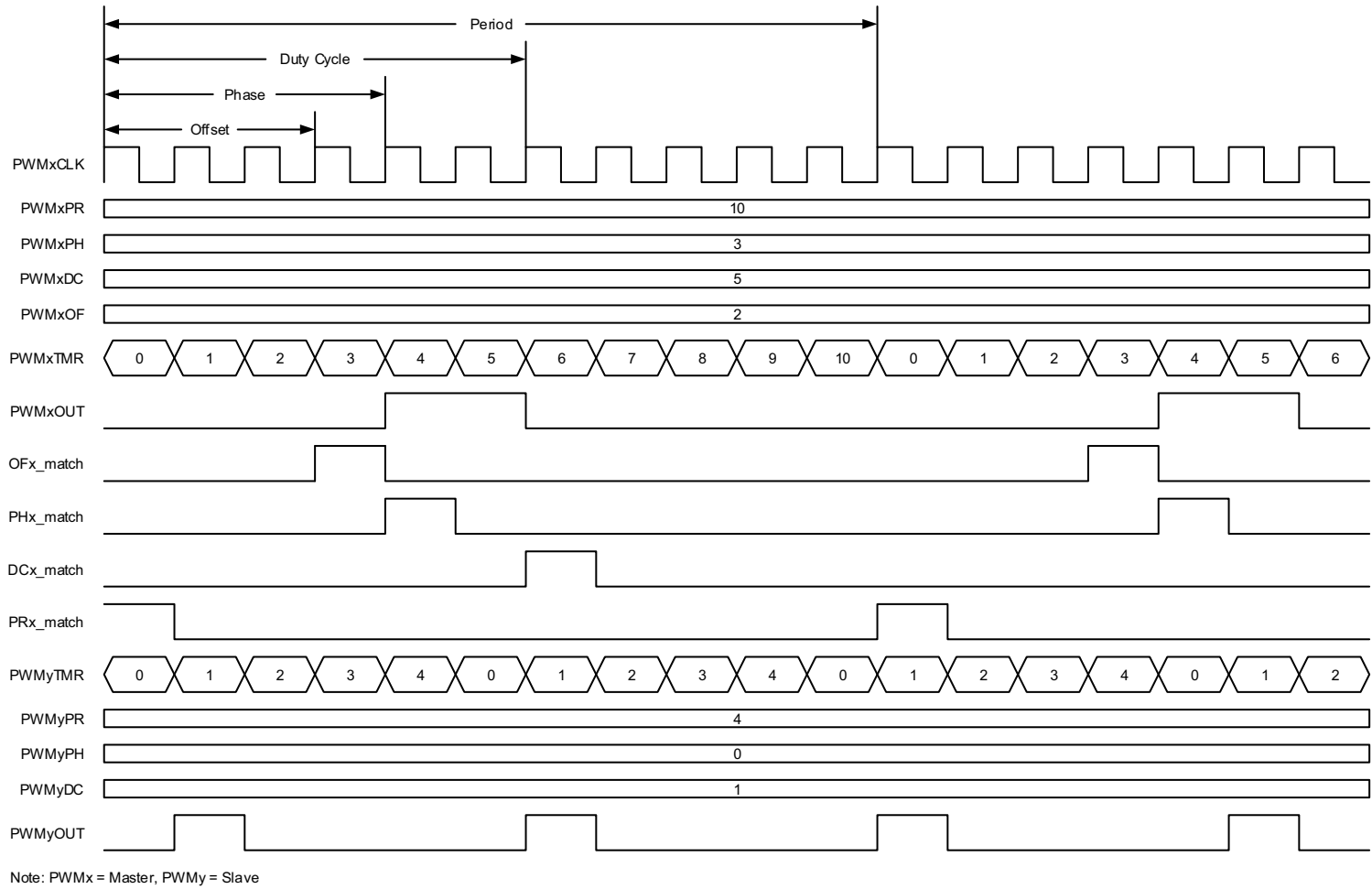
When a master is operating in Center-Aligned mode, the offset match event depends on which direction the PWMxTMR is counting. Clearing the OFO bit of the PWMxOFCON register will cause the OF\_match event to occur when the timer is counting up. Setting the OFO bit of the PWMxOFCON register will cause the OF\_match event to occur when the timer is counting down. The OFO bit is ignored in Non-Center-Aligned modes.

The OFO bit is double-buffered and requires setting the LDA bit to take effect when the PWM module is operating.

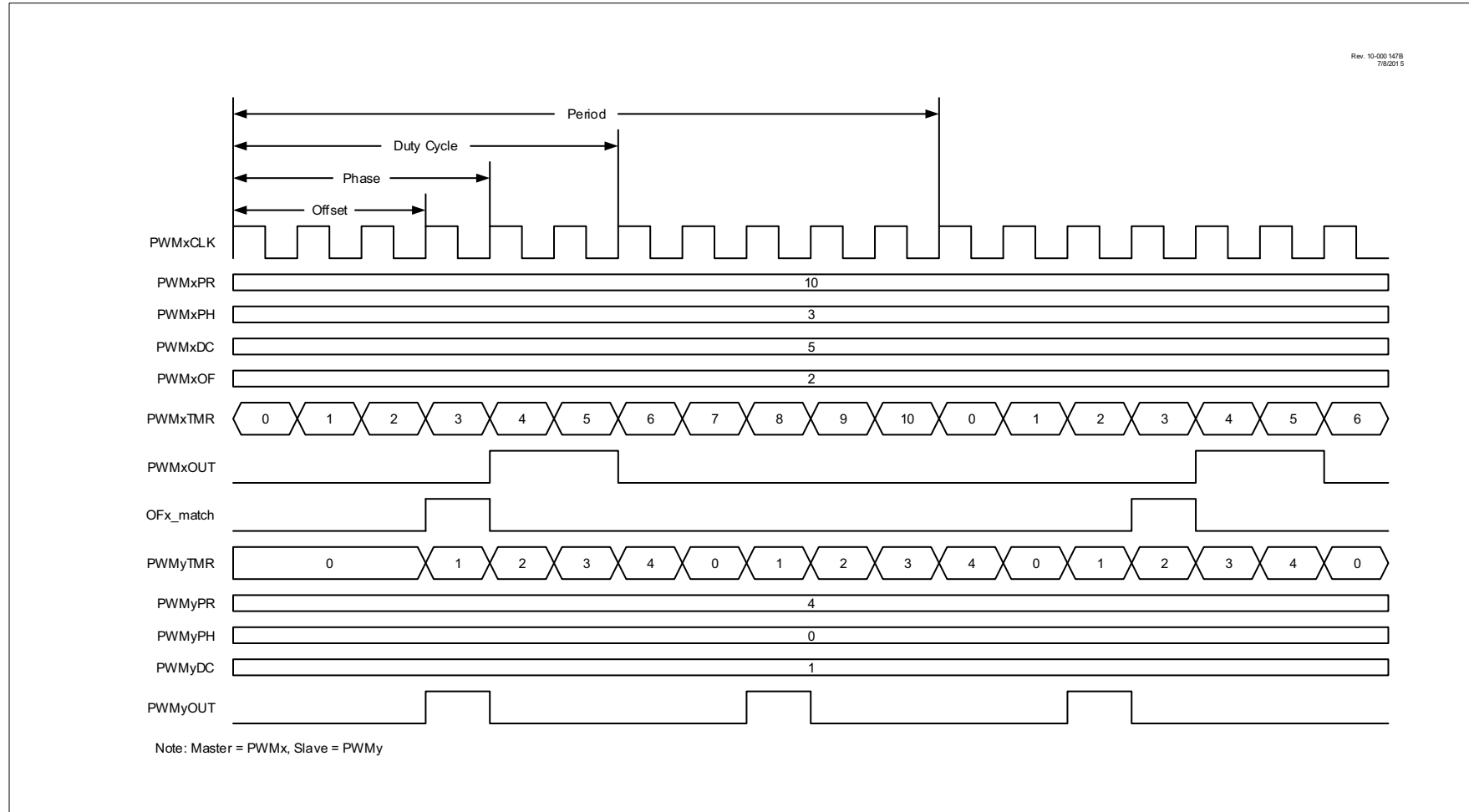
Detailed timing diagrams of Center-Aligned mode using offset match control in Independent Slave with Sync Start mode can be seen in [Figure 26-12](#) and [Figure 26-13](#).

**FIGURE 26-8: INDEPENDENT RUN MODE TIMING DIAGRAM**

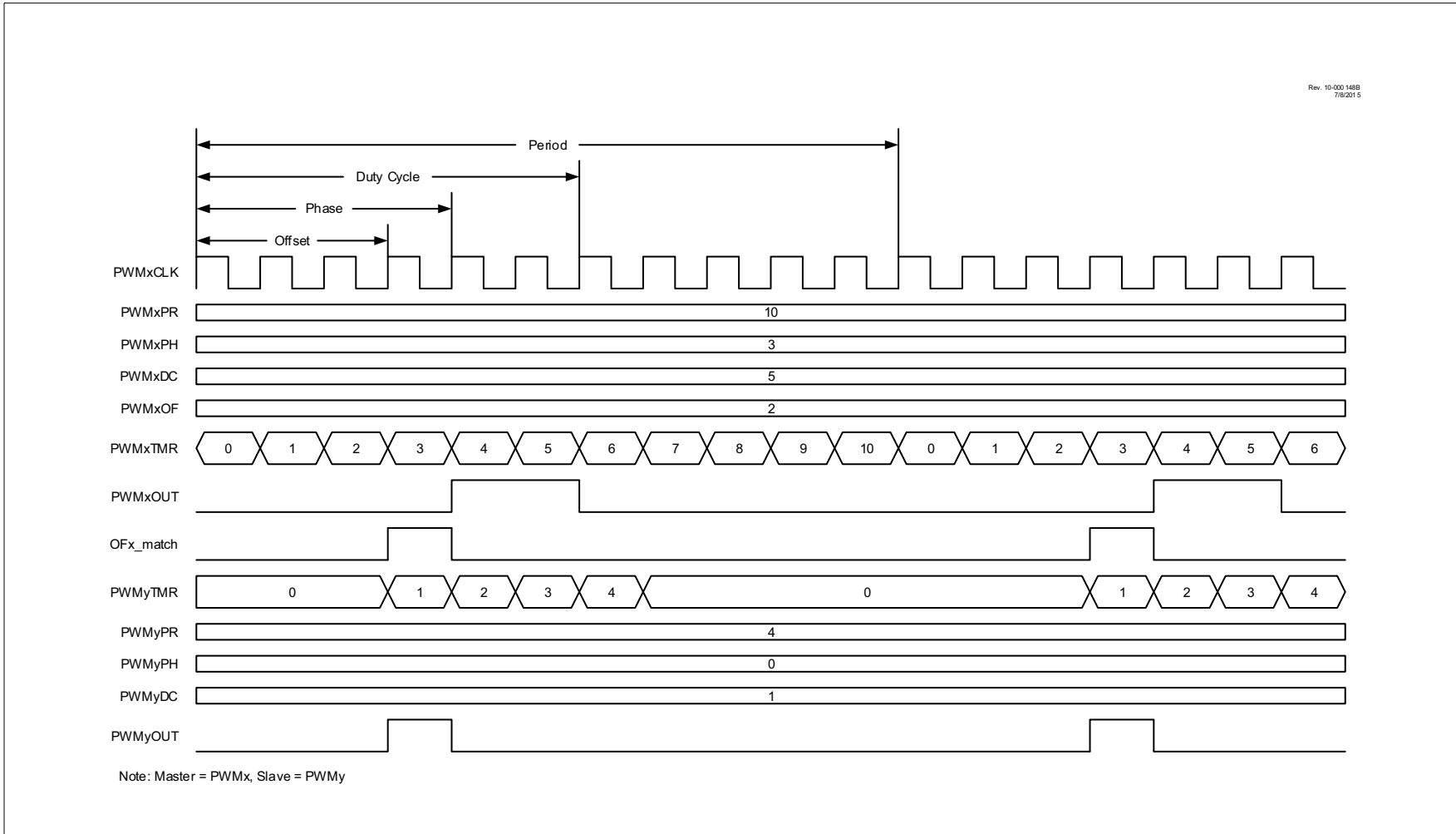
Rev. 10-000 146B  
7/8/2015



**FIGURE 26-9: SLAVE RUN MODE WITH SYNC START TIMING DIAGRAM**

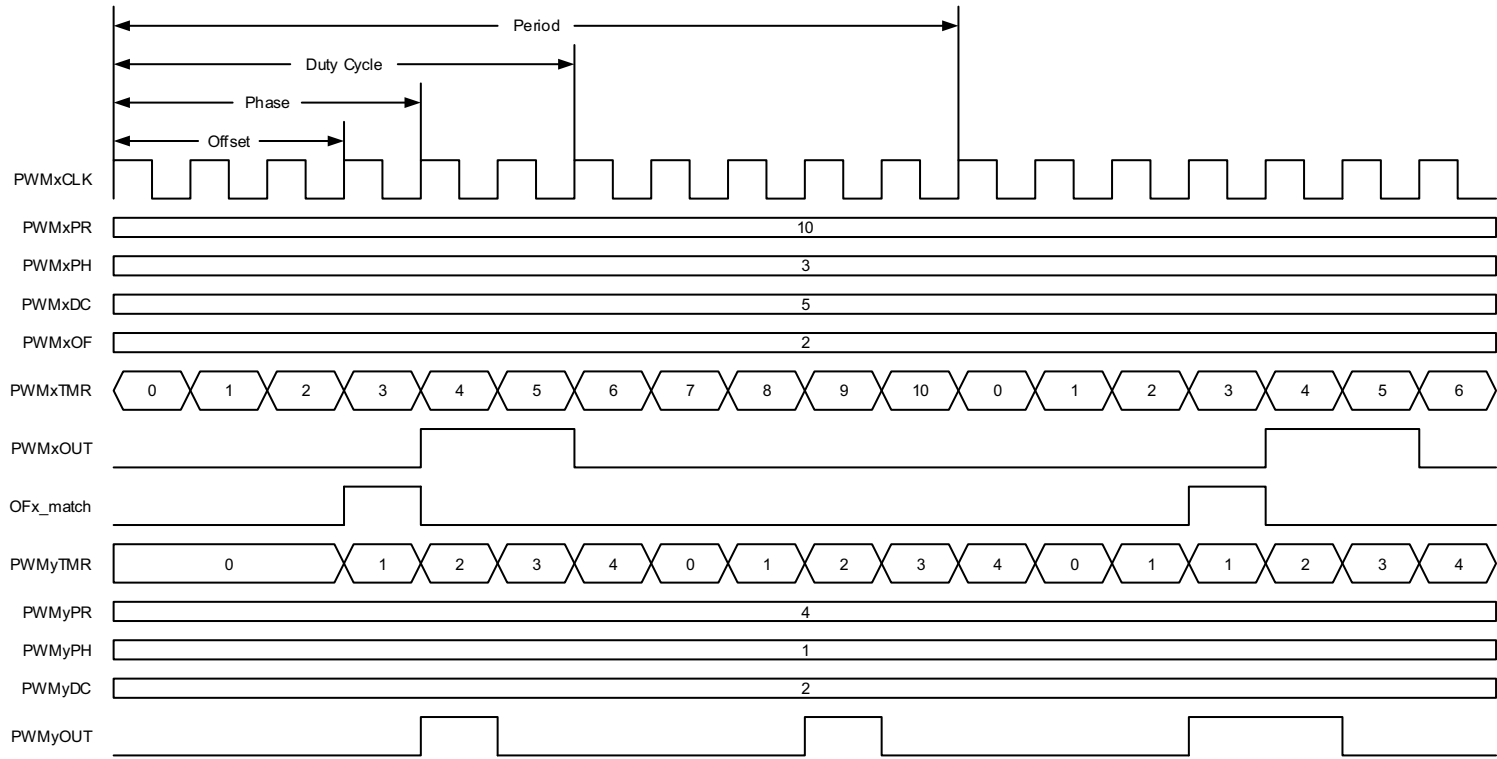


**FIGURE 26-10: ONE-SHOT SLAVE RUN MODE WITH SYNC START TIMING DIAGRAM**



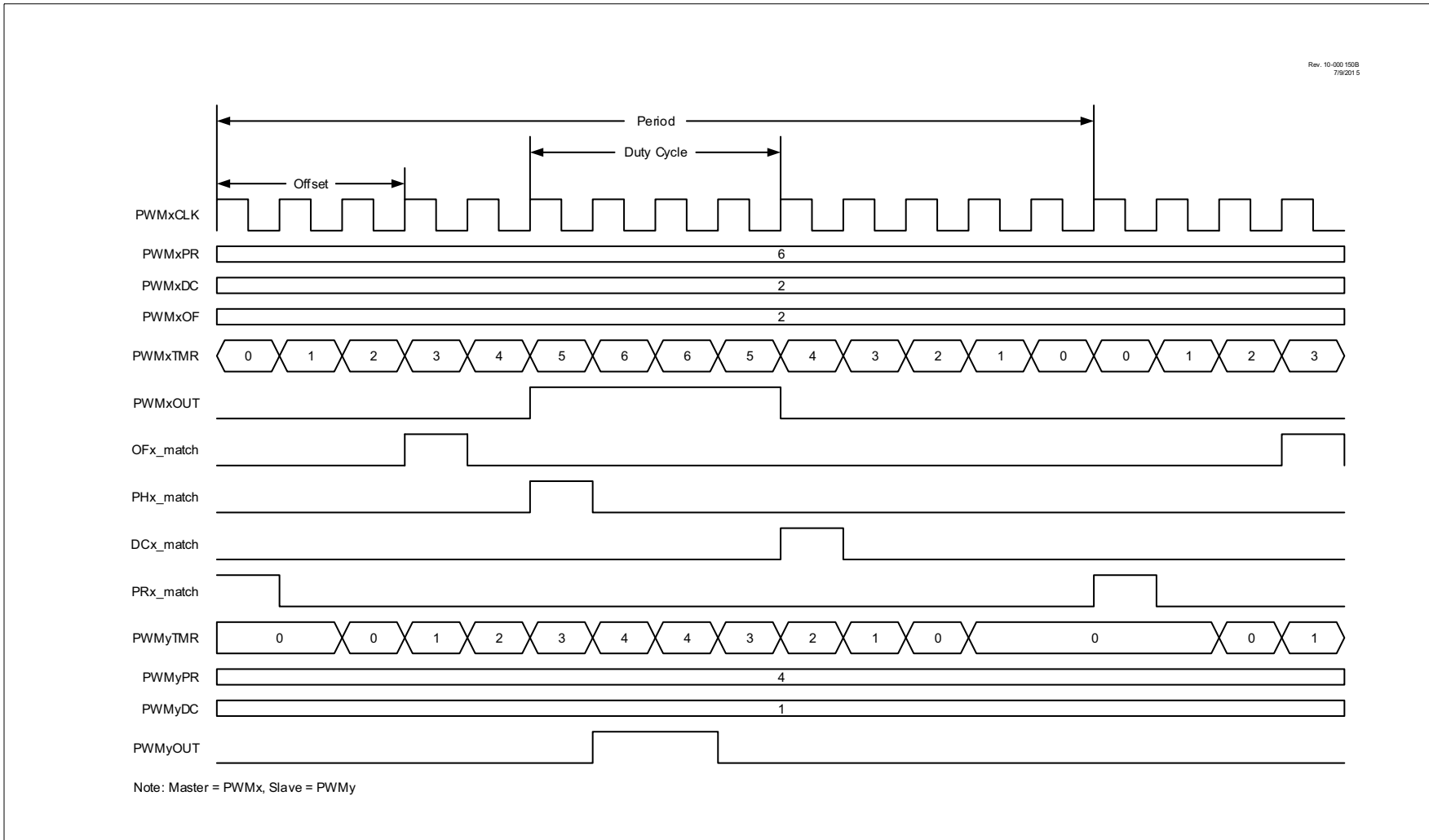
**FIGURE 26-11: CONTINUOUS SLAVE RUN MODE WITH IMMEDIATE RESET AND SYNC START TIMING DIAGRAM**

Rev. 10-00,149B  
7/9/2015



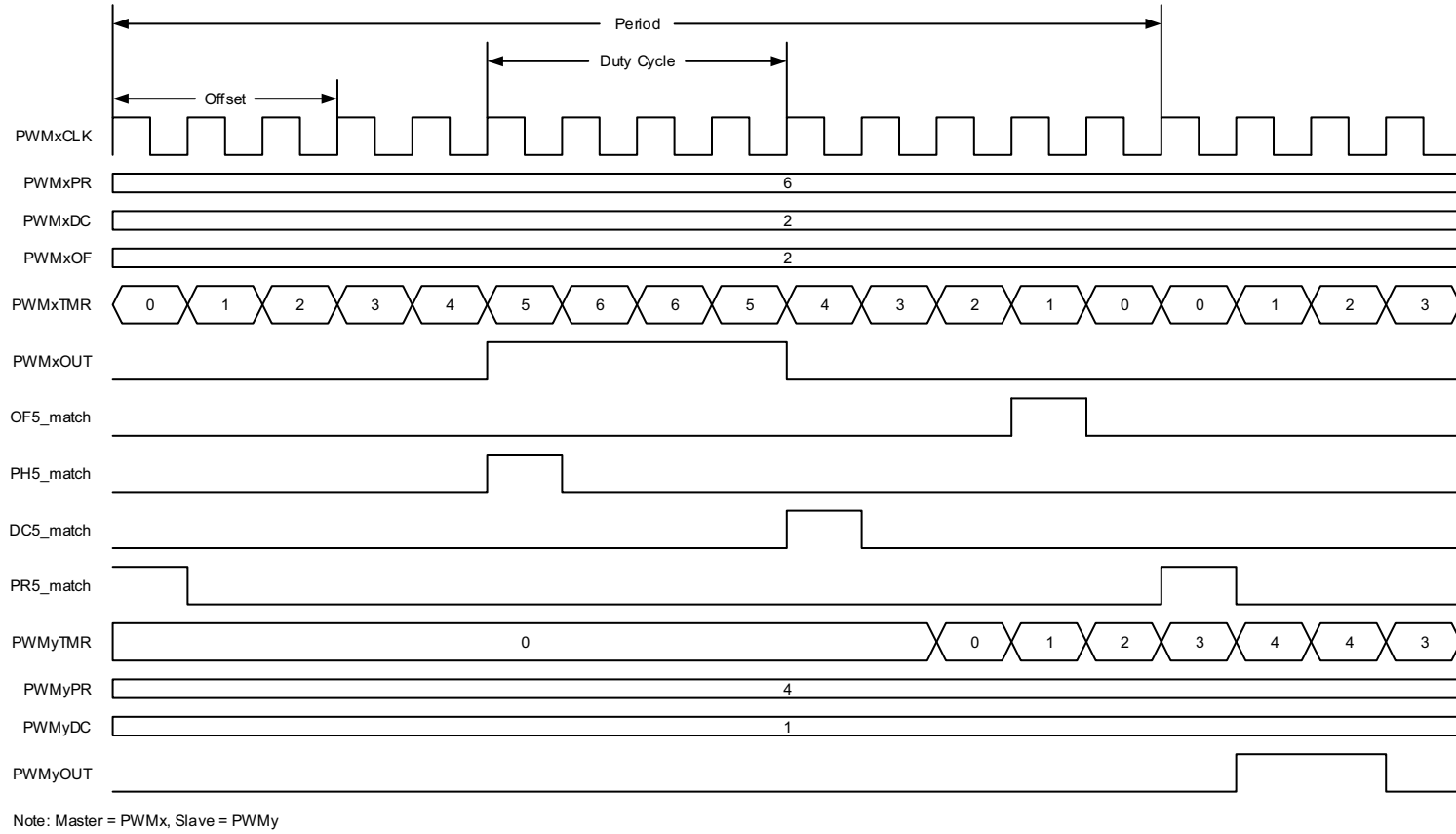
Note: Master= PWMx, Slave=PWMy

**FIGURE 26-12: OFFSET MATCH ON INCREMENTING TIMER TIMING DIAGRAM**



**FIGURE 26-13: OFFSET MATCH ON DECREMENTING TIMER TIMING DIAGRAM**

Rev. 10-000 151B  
7/9/2015





## 26.4 Reload Operation

Four of the PWM module control register pairs and one control bit are double-buffered so that all can be updated simultaneously. These include:

- PWMxPHH:PWMxPHL register pair
- PWMxDCH:PWMxDCL register pair
- PWMxPRH:PWMxPRL register pair
- PWMxOFH:PWMxOFL register pair
- ODO control bit

When written to, these registers do not immediately affect the operation of the PWM. By default, writes to these registers will not be loaded into the PWM operating buffer registers until after the arming conditions are met. The arming control has two methods of operation:

- Immediate
- Triggered

The LDT bit of the PWMxLDCON register controls the arming method. Both methods require the LDA bit to be set. All four buffer pairs will load simultaneously at the loading event.

### 26.4.1 IMMEDIATE RELOAD

When the LDT bit is clear, then the Immediate mode is selected and the buffers will be loaded at the first period event after the LDA bit is set. Immediate reloading is used when a PWM module is operating stand-alone or when the PWM module is operating as a master to other slave PWM modules.

### 26.4.2 TRIGGERED RELOAD

When the LDT bit is set, then the Triggered mode is selected and a trigger event is required for the LDA bit to take effect. The trigger source is the buffer load event of one of the other PWM modules in the device. The triggering source is selected by the LDS bit of the PWMxLDCON register. The buffers will be loaded at the first period event following the trigger event. Triggered reloading is used when a PWM module is operating as a slave to another PWM and it is necessary to synchronize the buffer reloads in both modules.

- |  |
|--|
| <p><b>Note 1:</b> The buffer load operation clears the LDA bit.</p> <p><b>2:</b> If the LDA bit is set at the same time as PWMxTMR = PWMxPR, the LDA bit is ignored until the next period event. Such is the case when triggered reload is selected and the triggering event occurs simultaneously with the target's period event.</p> |
|--|

## 26.5 Operation in Sleep Mode

Each PWM module will continue to operate in Sleep mode when either the HFINTOSC or LFINTOSC is selected as the clock source by PWMxCLKCON<1:0>.

## 26.6 Interrupts

Each PWM module has four independent interrupts based on the phase, duty cycle, period and offset match events. The interrupt flag is set on the rising edge of each of these signals. Refer to Figures 26-12 and 26-13 for detailed timing diagrams of the match signals.

## 26.7 Register Definitions: PWM Control

Long bit name prefixes for the 16-bit PWM peripherals are shown in Table 26-1. Refer to Section 1.1 “Register and Bit Naming Conventions” for more information.

**TABLE 26-1: BIT NAME PREFIXES**

Peripheral	Bit Name Prefix
PWM5	PWM5
PWM6 <sup>(1)</sup>	PWM6

**Note 1:** PIC16(L)F1768/9 devices only.

### REGISTER 26-1: PWM<sub>x</sub>CON: PWM<sub>x</sub> CONTROL REGISTER

R/W-0/0	U-0	R/HS/HC-0/0	R/W-0/0	R/W-0/0	R/W-0/0	U-0	U-0
EN	—	OUT	POL	MODE<1:0>		—	—
bit 7						bit 0	

**Legend:**

R = Readable bit	W = Writable bit	
HC = Hardware Clearable bit	HS = Hardware Settable bit	U = Unimplemented bit, read as '0'
'1' = Bit is set	'0' = Bit is cleared	-n/n = Value at POR and BOR/Value at all other Resets

- bit 7      **EN:** PWM<sub>x</sub> Module Enable bit  
           1 = Module is enabled  
           0 = Module is disabled
- bit 6      **Unimplemented:** Read as '0'
- bit 5      **OUT:** Output State of the PWM<sub>x</sub> Module bit
- bit 4      **POL:** PWM<sub>x</sub> Output Polarity Control bit  
           1 = PWM<sub>x</sub> output active state is low  
           0 = PWM<sub>x</sub> output active state is high
- bit 3-2    **MODE<1:0>:** PWM<sub>x</sub> Mode Control bits  
           11 = Center-Aligned mode  
           10 = Toggle On Match mode  
           01 = Set On Match mode  
           00 = Standard PWM mode
- bit 1-0    **Unimplemented:** Read as '0'

## REGISTER 26-2: PWMxINTE: PWMx INTERRUPT ENABLE REGISTER

U-0	U-0	U-0	U-0	R/W-0/0	R/W-0/0	R/W-0/0	R/W-0/0
—	—	—	—	OFIE	PHIE	DCIE	PRIE
bit 7							bit 0

### Legend:

R = Readable bit

W = Writable bit

u = Bit is unchanged

x = Bit is unknown

U = Unimplemented bit, read as '0'

'1' = Bit is set

'0' = Bit is cleared

-n/n = Value at POR and BOR/Value at all other Resets

- bit 7-4     **Unimplemented:** Read as '0'
- bit 3     **OFIE:** Offset Interrupt Enable bit
  - 1 = Interrupts CPU on offset match
  - 0 = Does not interrupt CPU on offset match
- bit 2     **PHIE:** Phase Interrupt Enable bit
  - 1 = Interrupts CPU on phase match
  - 0 = Does not interrupt CPU on phase match
- bit 1     **DCIE:** Duty Cycle Interrupt Enable bit
  - 1 = Interrupts CPU on duty cycle match
  - 0 = Does not interrupt CPU on duty cycle match
- bit 0     **PRIE:** Period Interrupt Enable bit
  - 1 = Interrupts CPU on period match
  - 0 = Does not interrupt CPU on period match

## REGISTER 26-3: PWMxINTF: PWMx INTERRUPT REQUEST REGISTER

U-0	U-0	U-0	U-0	R/W/HS-0/0	R/W/HS-0/0	R/W/HS-0/0	R/W/HS-0/0
—	—	—	—	OFIF <sup>(1)</sup>	PHIF <sup>(1)</sup>	DCIF <sup>(1)</sup>	PRIF <sup>(1)</sup>
bit 7							bit 0

### Legend:

R = Readable bit

W = Writable bit

HS = Hardware Settable bit

u = Bit is unchanged

x = Bit is unknown

U = Unimplemented bit, read as '0'

'1' = Bit is set

'0' = Bit is cleared

-n/n = Value at POR and BOR/Value at all other Resets

bit 7-4 **Unimplemented:** Read as '0'

bit 3 **OFIF:** Offset Interrupt Flag bit<sup>(1)</sup>

1 = Offset match event occurred

0 = Offset match event did not occur

bit 2 **PHIF:** Phase Interrupt Flag bit<sup>(1)</sup>

1 = Phase match event occurred

0 = Phase match event did not occur

bit 1 **DCIF:** Duty Cycle Interrupt Flag bit<sup>(1)</sup>

1 = Duty cycle match event occurred

0 = Duty cycle match event did not occur

bit 0 **PRIF:** Period Interrupt Flag bit<sup>(1)</sup>

1 = Period match event occurred

0 = Period match event did not occur

**Note 1:** Bit is forced clear by hardware while module is disabled (EN = 0).

## REGISTER 26-4: PWMxCLKCON: PWMx CLOCK CONTROL REGISTER

U-0	R/W-0/0	R/W-0/0	R/W-0/0	U-0	U-0	R/W-0/0	R/W-0/0
—	PS<2:0>			—	—	CS<1:0>	
bit 7				bit 0			

### Legend:

R = Readable bit

W = Writable bit

u = Bit is unchanged

x = Bit is unknown

U = Unimplemented bit, read as '0'

'1' = Bit is set

'0' = Bit is cleared

-n/n = Value at POR and BOR/Value at all other Resets

bit 7           **Unimplemented:** Read as '0'

bit 6-4       **PS<2:0>:** Clock Source Prescaler Select bits

111 = Divide clock source by 128

110 = Divide clock source by 64

101 = Divide clock source by 32

100 = Divide clock source by 16

011 = Divide clock source by 8

010 = Divide clock source by 4

001 = Divide clock source by 2

000 = No Prescaler

bit 3-2       **Unimplemented:** Read as '0'

bit 1-0       **CS<1:0>:** Clock Source Select bits

11 = Reserved

10 = LFINTOSC (continues to operate during Sleep)

01 = HFINTOSC (continues to operate during Sleep)

00 = Fosc

## REGISTER 26-5: PWMxLDCON: PWMx RELOAD TRIGGER SOURCE SELECT REGISTER

R/W/HC-0/0	R/W-0/0	U-0	U-0	U-0	U-0	U-0	R/W-0/0
LDA <sup>(1)</sup>	LDT <sup>(3)</sup>	—	—	—	—	—	LDS <sup>(2,3)</sup>
bit 7							bit 0

### Legend:

R = Readable bit	W = Writable bit	HC = Hardware Clearable bit
u = Bit is unchanged	x = Bit is unknown	U = Unimplemented bit, read as '0'
'1' = Bit is set	'0' = Bit is cleared	-n/n = Value at POR and BOR/Value at all other Resets

- bit 7      **LDA:** Load Buffer Armed bit<sup>(1)</sup>  
If LDT = 1:  
 1 = Loads the ODO bit, and OFx, PHx, DCx and PRx buffers at the end of the period in which the selected trigger occurs  
 0 = Does not load buffers, load has completed  
If LDT = 0:  
 1 = Loads the ODO bit, and OFx, PHx, DCx and PRx buffers at the end of the current period  
 0 = Does not load buffers, load has completed
- bit 6      **LDT:** Load Buffer on Trigger bit<sup>(3)</sup>  
 1 = Waits for trigger selected by the LDS<1:0> bits to occur before enabling the LDA bit  
 0 = Load triggering is disabled; buffer loads are controlled by the LDA bit alone
- bit 5-1    **Unimplemented:** Read as '0'
- bit 0      **LDS:** Load Trigger Source Select bit<sup>(2,3)</sup>  
 1 = LD6\_trigger  
 0 = LD5\_trigger

- Note 1:** This bit is cleared by the module after a reload operation. It can be cleared in software to clear an existing arming event.
- 2:** The source corresponding to a PWM module's own LDx\_trigger is reserved.
- 3:** PIC16(L)F1768/9 only.

## REGISTER 26-6: PWMxOFCON: PWMx OFFSET TRIGGER SOURCE SELECT REGISTER

U-0	R/W-0/0	R/W-0/0	R/W-0/0	U-0	U-0	U-0	R/W-0/0
—	OFM<1:0> <sup>(2)</sup>	OFO <sup>(1)</sup>	—	—	—	—	OFS <sup>(1,2)</sup>
bit 7							bit 0

### Legend:

R = Readable bit	W = Writable bit	
u = Bit is unchanged	x = Bit is unknown	U = Unimplemented bit, read as '0'
'1' = Bit is set	'0' = Bit is cleared	-n/n = Value at POR and BOR/Value at all other Resets

- bit 7      **Unimplemented:** Read as '0'
- bit 6-5    **OFM<1:0>:** Offset Mode Select bits<sup>(2)</sup>  
           11 = Continuous Slave Run mode with offset triggered timer Reset and synchronized start  
           10 = One-Shot Slave Run mode with offset triggered synchronized start  
           01 = Slave Run mode with offset triggered synchronized start  
           00 = Independent Run mode
- bit 4      **OFO:** Offset Match Output Control bit<sup>(1)</sup>  
           If MODE<1:0> = 11 (PWM Center-Aligned mode):  
           1 = OFx\_match occurs when the PWMxTMR is counting up  
           0 = OFx\_match occurs when the PWMxTMR is counting down  
           If MODE<1:0> = 00, 01 or 10 (All Other modes):  
           This bit is ignored.
- bit 3-1    **Unimplemented:** Read as '0'
- bit 0      **OFS:** Offset Trigger Source Select bit<sup>(1,2)</sup>  
           1 = OF6\_match  
           0 = OF5\_match

- Note 1:** The source corresponding to the PWM module's own OFx\_match is reserved.  
**Note 2:** PIC16(L)F1768/9 only.

## REGISTER 26-7: PWMxPHH: PWMx PHASE COUNT HIGH REGISTER

R/W-x/u	R/W-x/u	R/W-x/u	R/W-x/u	R/W-x/u	R/W-x/u	R/W-x/u	R/W-x/u
PH<15:8>							
bit 7							bit 0

### Legend:

R = Readable bit	W = Writable bit	
u = Bit is unchanged	x = Bit is unknown	U = Unimplemented bit, read as '0'
'1' = Bit is set	'0' = Bit is cleared	-n/n = Value at POR and BOR/Value at all other Resets

bit 7-0      **PH<15:8>**: PWMx Phase High bits  
Upper eight bits of PWMx phase count.

## REGISTER 26-8: PWMxPHL: PWMx PHASE COUNT LOW REGISTER

R/W-x/u	R/W-x/u	R/W-x/u	R/W-x/u	R/W-x/u	R/W-x/u	R/W-x/u	R/W-x/u
PH<7:0>							
bit 7							bit 0

### Legend:

R = Readable bit	W = Writable bit	
u = Bit is unchanged	x = Bit is unknown	U = Unimplemented bit, read as '0'
'1' = Bit is set	'0' = Bit is cleared	-n/n = Value at POR and BOR/Value at all other Resets

bit 7-0      **PH<7:0>**: PWMx Phase Low bits  
Lower eight bits of PWMx phase count.



## REGISTER 26-9: PWMxDCH: PWMx DUTY CYCLE COUNT HIGH REGISTER

R/W-x/u	R/W-x/u	R/W-x/u	R/W-x/u	R/W-x/u	R/W-x/u	R/W-x/u	R/W-x/u
DC<15:8>							
bit 7							bit 0

### Legend:

R = Readable bit	W = Writable bit	
u = Bit is unchanged	x = Bit is unknown	U = Unimplemented bit, read as '0'
'1' = Bit is set	'0' = Bit is cleared	-n/n = Value at POR and BOR/Value at all other Resets

bit 7-0      **DC<15:8>**: PWMx Duty Cycle High bits  
Upper eight bits of PWMx duty cycle count.

## REGISTER 26-10: PWMxDCL: PWMx DUTY CYCLE COUNT LOW REGISTER

R/W-x/u	R/W-x/u	R/W-x/u	R/W-x/u	R/W-x/u	R/W-x/u	R/W-x/u	R/W-x/u
DC<7:0>							
bit 7							bit 0

### Legend:

R = Readable bit	W = Writable bit	
u = Bit is unchanged	x = Bit is unknown	U = Unimplemented bit, read as '0'
'1' = Bit is set	'0' = Bit is cleared	-n/n = Value at POR and BOR/Value at all other Resets

bit 7-0      **DC<7:0>**: PWMx Duty Cycle Low bits  
Lower eight bits of PWMx duty cycle count.

## REGISTER 26-11: PWMxPRH: PWMx PERIOD COUNT HIGH REGISTER

R/W-x/u	R/W-x/u	R/W-x/u	R/W-x/u	R/W-x/u	R/W-x/u	R/W-x/u	R/W-x/u
PR<15:8>							
bit 7							bit 0

**Legend:**

R = Readable bit	W = Writable bit	
u = Bit is unchanged	x = Bit is unknown	U = Unimplemented bit, read as '0'
'1' = Bit is set	'0' = Bit is cleared	-n/n = Value at POR and BOR/Value at all other Resets

bit 7-0      **PR<15:8>**: PWMx Period High bits  
Upper eight bits of PWMx period count.

## REGISTER 26-12: PWMxPRL: PWMx PERIOD COUNT LOW REGISTER

R/W-x/u	R/W-x/u	R/W-x/u	R/W-x/u	R/W-x/u	R/W-x/u	R/W-x/u	R/W-x/u
PR<7:0>							
bit 7							bit 0

**Legend:**

R = Readable bit	W = Writable bit	
u = Bit is unchanged	x = Bit is unknown	U = Unimplemented bit, read as '0'
'1' = Bit is set	'0' = Bit is cleared	-n/n = Value at POR and BOR/Value at all other Resets

bit 7-0      **PR<7:0>**: PWMx Period Low bits  
Lower eight bits of PWMx period count.

## REGISTER 26-13: PWMxOFH: PWMx OFFSET COUNT HIGH REGISTER

R/W-x/u	R/W-x/u	R/W-x/u	R/W-x/u	R/W-x/u	R/W-x/u	R/W-x/u	R/W-x/u
OF<15:8>							
bit 7							bit 0

### Legend:

R = Readable bit	W = Writable bit	
u = Bit is unchanged	x = Bit is unknown	U = Unimplemented bit, read as '0'
'1' = Bit is set	'0' = Bit is cleared	-n/n = Value at POR and BOR/Value at all other Resets

bit 7-0      **OF<15:8>**: PWMx Offset High bits  
Upper eight bits of PWMx offset count.

## REGISTER 26-14: PWMxOFL: PWMx OFFSET COUNT LOW REGISTER

R/W-x/u	R/W-x/u	R/W-x/u	R/W-x/u	R/W-x/u	R/W-x/u	R/W-x/u	R/W-x/u
OF<7:0>							
bit 7							bit 0

### Legend:

R = Readable bit	W = Writable bit	
u = Bit is unchanged	x = Bit is unknown	U = Unimplemented bit, read as '0'
'1' = Bit is set	'0' = Bit is cleared	-n/n = Value at POR and BOR/Value at all other Resets

bit 7-0      **OF<7:0>**: PWMx Offset Low bits  
Lower eight bits of PWMx offset count.

## REGISTER 26-15: PWMxTMRH: PWMx TIMER HIGH REGISTER

R/W-0/0	R/W-0/0	R/W-0/0	R/W-0/0	R/W-0/0	R/W-0/0	R/W-0/0	R/W-0/0
TMR<15:8>							
bit 7							bit 0

### Legend:

R = Readable bit

W = Writable bit

u = Bit is unchanged

x = Bit is unknown

U = Unimplemented bit, read as '0'

'1' = Bit is set

'0' = Bit is cleared

-n/n = Value at POR and BOR/Value at all other Resets

bit 7-0

**TMR<15:8>**: PWMx Timer High bits

Upper eight bits of PWMx timer counter.

## REGISTER 26-16: PWMxTMRL: PWMx TIMER LOW REGISTER

R/W-0/0	R/W-0/0	R/W-0/0	R/W-0/0	R/W-0/0	R/W-0/0	R/W-0/0	R/W-0/0
TMR<7:0>							
bit 7							bit 0

### Legend:

R = Readable bit

W = Writable bit

u = Bit is unchanged

x = Bit is unknown

U = Unimplemented bit, read as '0'

'1' = Bit is set

'0' = Bit is cleared

-n/n = Value at POR and BOR/Value at all other Resets

bit 7-0

**TMR<7:0>**: PWMx Timer Low bits

Lower eight bits of PWMx timer counter.

**Note:** There are no long and short bit name variants for the following three mirror registers.

## REGISTER 26-17: PWMEN: PWMEN BIT MIRROR REGISTER

U-0	U-0	R/W-0/0	R/W-0/0	U-0	U-0	U-0	U-0
—	—	MPWM6EN <sup>(1)</sup>	MPWM5EN	—	—	—	—
bit 7							bit 0

### Legend:

R = Readable bit                      W = Writable bit                      U = Unimplemented bit, read as '0'  
 '1' = Bit is set                          '0' = Bit is cleared                      -n/n = Value at POR and BOR/Value at all other Resets

bit 7-6            **Unimplemented:** Read as '0'

bit 5-4            **MPWMxEN:** PWM6<sup>(1)</sup>/PWM5 Enable bits  
 Mirror copy of each PWMx module's PWMxCON<7> bit.

bit 3-0            **Unimplemented:** Read as '0'

**Note 1:** PIC16(L)F1768/9 only. (Applies also to [Register 26-18](#) and [Register 26-19](#).)

## REGISTER 26-18: PWMLD: LDA BIT MIRROR REGISTER

U-0	U-0	R/W-0/0	R/W-0/0	U-0	U-0	U-0	U-0
—	—	MPWM6LD <sup>(1)</sup>	MPWM5LD	—	—	—	—
bit 7							bit 0

### Legend:

R = Readable bit                      W = Writable bit                      U = Unimplemented bit, read as '0'  
 '1' = Bit is set                          '0' = Bit is cleared                      -n/n = Value at POR and BOR/Value at all other Resets

bit 7-6            **Unimplemented:** Read as '0'

bit 5-4            **MPWMxLDA:** PWM6<sup>(1)</sup>/PWM5 LDA bits  
 Mirror copy of each PWMx module's PWMxLDLCON<7> bit.

bit 3-0            **Unimplemented:** Read as '0'

## REGISTER 26-19: PWMOUT: PWMOUT BIT MIRROR REGISTER

U-0	U-0	R/W-0/0	R/W-0/0	U-0	U-0	U-0	U-0
—	—	MPWM6OUT <sup>(1)</sup>	MPWM5OUT	—	—	—	—
bit 7							bit 0

### Legend:

R = Readable bit                      W = Writable bit                      U = Unimplemented bit, read as '0'  
 '1' = Bit is set                          '0' = Bit is cleared                      -n/n = Value at POR and BOR/Value at all other Resets

bit 7-6            **Unimplemented:** Read as '0'

bit 5-4            **MPWMxOUT:** PWM6<sup>(1)</sup>/PWM5 OUT bits  
 Mirror copy of each PWMx module's PWMxCON<5> bit.

bit 3-0            **Unimplemented:** Read as '0'

**TABLE 26-2: SUMMARY OF REGISTERS ASSOCIATED WITH PWMx**

Name	Bit 7	Bit 6	Bit 5	Bit 4	Bit 3	Bit 2	Bit 1	Bit 0	Register on Page	
OSCCON	SPLLEN	IRCF<3:0>				—	SCS<1:0>		84	
PWMEN	—	—	MPWM6EN <sup>(1)</sup>	MPWM5EN	—	—	—	—	293	
PWMLD	—	—	MPWM6LD <sup>(1)</sup>	MPWM5LD	—	—	—	—	293	
PWMOUT	—	—	MPWM6OUT <sup>(1)</sup>	MPWM5OUT	—	—	—	—	293	
PWM5PHL	PH<7:0>								288	
PWM5PHH	PH<15:8>								288	
PWM5DCL	DC<7:0>								289	
PWM5DCH	DC<15:8>								289	
PWM5PRH	PR<15:8>								290	
PWM5PRL	PR<7:0>								290	
PWM5OFH	OF<15:8>								291	
PWM5OFL	OF<7:0>								291	
PWM5TMRH	TMR<15:8>								292	
PWM5TMRL	TMR<7:0>								292	
PWM5CON	EN	—	OUT	POL	MODE<1:0>		—	—	282	
PWM5INTE	—	—	—	—	OFIE	PHIE	DCIE	PRIE	283	
PWM5INTF	—	—	—	—	OFIF	PHIF	DCIF	PRIF	284	
PWM5CLKCON	—	PS<2:0>				—	—	CS<1:0>		285
PWM5LDCON	LDA	LDT <sup>(1)</sup>	—	—	—	—	—	LDS <sup>(1)</sup>	286	
PWM5OFCON	—	OFM<1:0> <sup>(1)</sup>		OFO	—	—	—	OFS <sup>(1)</sup>	287	
PWM6PHL <sup>(1)</sup>	PH<7:0>								288	
PWM6PHH <sup>(1)</sup>	PH<15:8>								288	
PWM6DCL <sup>(1)</sup>	DC<7:0>								289	
PWM6DCH <sup>(1)</sup>	DC<15:8>								289	
PWM6PRL <sup>(1)</sup>	PR<7:0>								290	
PWM6PRH <sup>(1)</sup>	PR<15:8>								290	
PWM6OFL <sup>(1)</sup>	OF<7:0>								291	
PWM6OFH <sup>(1)</sup>	OF<15:8>								291	
PWM6TMRL <sup>(1)</sup>	TMR<7:0>								292	
PWM6TMRH <sup>(1)</sup>	TMR<15:8>								292	
PWM6CON <sup>(1)</sup>	EN	—	OUT	POL	MODE<1:0>		—	—	282	
PWM6INTE <sup>(1)</sup>	—	—	—	—	OFIE	PHIE	DCIE	PRIE	283	
PWM6INTF <sup>(1)</sup>	—	—	—	—	OFIF	PHIF	DCIF	PRIF	284	
PWM6CLKCON <sup>(1)</sup>	—	PS<2:0>				—	—	CS<1:0>		285
PWM6LDCON <sup>(1)</sup>	LDA	LDT <sup>(1)</sup>	—	—	—	—	—	LDS <sup>(1)</sup>	286	
PWM6OFCON <sup>(1)</sup>	—	OFM<1:0> <sup>(1)</sup>		OFO	—	—	—	OFS <sup>(1)</sup>	287	

**Legend:** — = unimplemented location, read as '0'. Shaded cells are not used by PWM.

**Note 1:** PIC16(L)F1768/9 only

**TABLE 26-3: SUMMARY OF CONFIGURATION WORDS WITH CLOCK SOURCES**

Name	Bits	Bit -/7	Bit -/6	Bit 13/5	Bit 12/4	Bit 11/3	Bit 10/2	Bit 9/1	Bit 8/0	Register on Page
CONFIG1	13:8	—	—	FCMEN	IESO	CLKOUTEN	BOREN<1:0>		—	63
	7:0	CP	MCLRE	PWRTE	WDTE<1:0>		FOSC<2:0>		—	

**Legend:** — = unimplemented location, read as '0'. Shaded cells are not used by clock sources.

## 27.0 COMPLEMENTARY OUTPUT GENERATOR (COG) MODULE

The primary purpose of the Complementary Output Generator (COG) is to convert a single output PWM signal into a two-output complementary PWM signal. The COG can also convert two separate input events into a single or complementary PWM output.

The COG PWM frequency and duty cycle are determined by a rising event input and a falling event input. The rising event and falling event may be the same source. Sources may be synchronous or asynchronous to the COG\_clock.

The rate at which the rising event occurs determines the PWM frequency. The time from the rising event to the falling event determines the duty cycle.

A selectable clock input is used to generate the phase delay, blanking and dead-band times. Dead-band time can also be generated with a programmable delay chain, which is independent from all clock sources.

Simplified block diagrams of the various COG modes are shown in [Figure 27-2](#) through [Figure 27-6](#).

The COG module has the following features:

- Six modes of operation:
  - Steered PWM mode
  - Synchronous Steered PWM mode
  - Forward Full-Bridge mode
  - Reverse Full-Bridge mode
  - Half-Bridge mode
  - Push-Pull mode
- Selectable COG\_clock clock source
- Independently selectable rising event sources
- Independently selectable falling event sources
- Independently selectable edge or level event sensitivity
- Independent output polarity selection
- Phase delay with independent rising and falling delay times
- Dead-band control with:
  - independent rising and falling event dead-band times
  - Synchronous and asynchronous timing
- Blanking control with independent rising and falling event blanking times
- Auto-shutdown control with:
  - Independently selectable shutdown sources
  - Auto-restart enable
  - Auto-shutdown pin override control (high, low, off and High-Z)

## 27.1 Output to Pins (all modes)

The COG peripheral has four outputs: COGA, COGB, COGC and COGD.

The operating mode, selected with the MD<2:0> bits of the COGxCON0 register, determines the waveform available at each output. An individual peripheral source control for each device pin selects the pin or pins at which the outputs will appear. Please refer to the RxyPPS register ([Register 12-2](#)) for more information.

## 27.2 Event-Driven PWM (All Modes)

Besides generating PWM and complementary outputs from a single PWM input, the COG can also generate PWM waveforms from a periodic rising event and a separate falling event. In this case, the falling event is usually derived from analog feedback within the external PWM driver circuit. In this configuration, high-power switching transients may trigger a false falling event that needs to be blanked out. The COG can be configured to blank falling (and rising) event inputs for a period of time immediately following the rising (and falling) event drive output. This is referred to as input blanking and is covered in [Section 27.8 “Blanking Control”](#).

It may be necessary to guard against the possibility of external circuit Faults. In this case, the active drive must be terminated before the Fault condition causes damage. This is referred to as auto-shutdown and is covered in [Section 27.10 “Auto-Shutdown Control”](#).

The COG can be configured to operate in phase delayed conjunction with another PWM. The active drive cycle is delayed from the rising event by a phase delay timer. Phase delay is covered in more detail in [Section 27.9 “Phase Delay”](#).

A typical operating waveform, with phase delay and dead band, generated from a single CCP1 input is shown in [Figure 27-10](#).

## 27.3 Modes of Operation

### 27.3.1 STEERED PWM MODES

In Steered PWM mode, the PWM signal derived from the input event sources is output as a single-phase PWM which can be steered to any combination of the four COG outputs. Output steering takes effect on the instruction cycle following the write to the COGxSTR register.

Synchronous Steered PWM mode is identical to the Steered PWM mode except that changes to the output steering take effect on the first rising event after the COGxSTR register write. Static output data is not synchronized.

Steering mode configurations are shown in [Figure 27-2](#) and [Figure 27-3](#).

Steered PWM and Synchronous Steered PWM modes are selected by setting the MD<2:0> bits of the COGxCON0 register ([Register 27-1](#)) to '000' and '001', respectively.

### 27.3.2 FULL-BRIDGE MODES

In both Forward and Reverse Full-Bridge modes, two of the four COG outputs are active and the other two are inactive. Of the two active outputs, one is modulated by the PWM input signal and the other is on at 100% duty cycle. When the direction is changed, the dead-band time is inserted to delay the modulated output. This gives the unmodulated driver time to shut down, thereby, preventing shoot-through current in the series connected power devices.

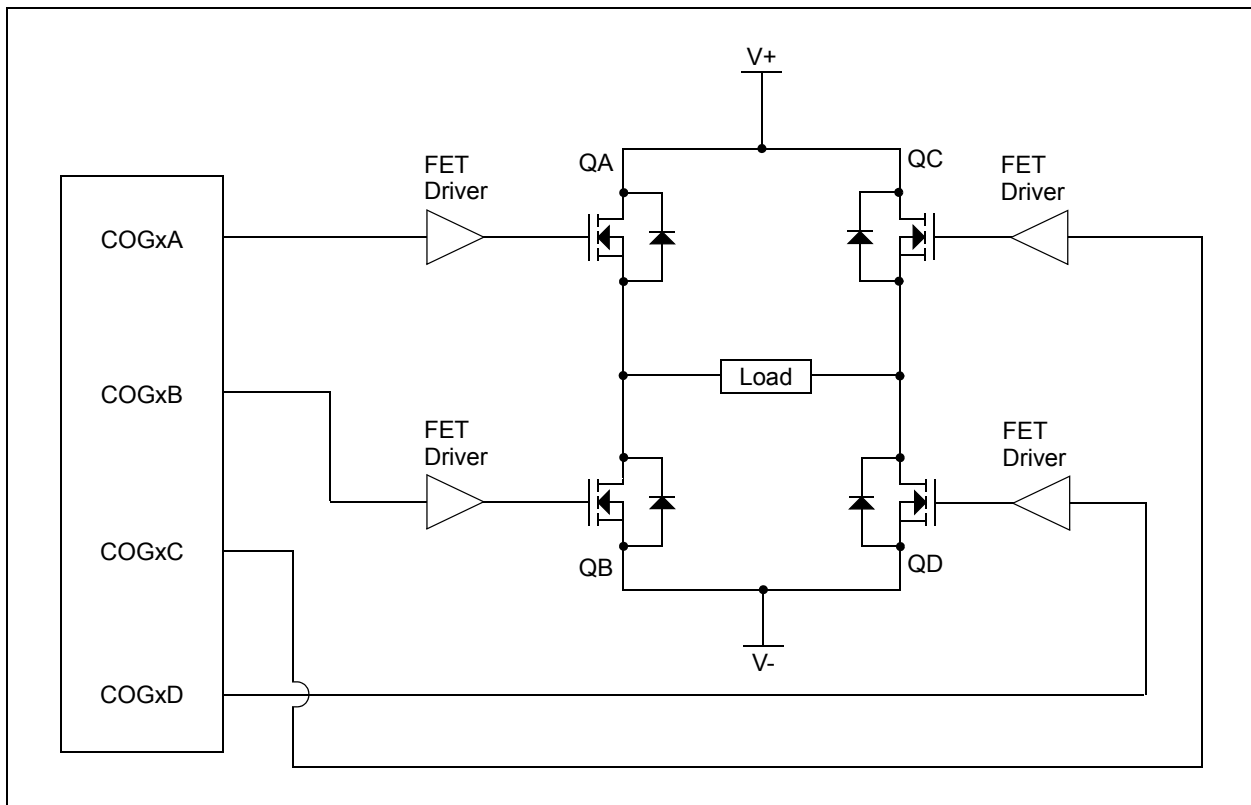
In Forward Full-Bridge mode, the PWM input modulates the COGxD output and drives the COGA output at 100%.

In Reverse Full-Bridge mode, the PWM input modulates the COGxB output and drives the COGxC output at 100%.

The full-bridge configuration is shown in [Figure 27-4](#). Typical full-bridge waveforms are shown in [Figure 27-12](#) and [Figure 27-13](#).

Full-Bridge Forward and Full-Bridge Reverse modes are selected by setting the MD<2:0> bits of the COGxCON0 register to '010' and '011', respectively.

**FIGURE 27-1: EXAMPLE OF FULL-BRIDGE APPLICATION**





## 27.3.3 HALF-BRIDGE MODE

In Half-Bridge mode, the COG generates a two-output complementary PWM waveform from rising and falling event sources. In the simplest configuration, the rising and falling event sources are the same signal, which is a PWM signal with the desired period and duty cycle. The COG converts this single PWM input into a dual complementary PWM output. The frequency and duty cycle of the dual PWM output match those of the single input PWM signal. The off-to-on transition of each output can be delayed from the on-to-off transition of the other output, thereby, creating a time immediately after the PWM transition where neither output is driven. This is referred to as dead-band time and is covered in [Section 27.7 “Dead-Band Control”](#).

The Half-Bridge configuration is shown in [Figure 27-5](#). A typical operating waveform, with dead band, generated from a single CCP1 input is shown in [Figure 27-9](#).

The primary output is available on either, or both, COGxA and COGxC. The complementary output is available on either, or both, COGxB and COGxD.

Half-Bridge mode is selected by setting the MD<2:0> bits of the COGxCON0 register to '100'.

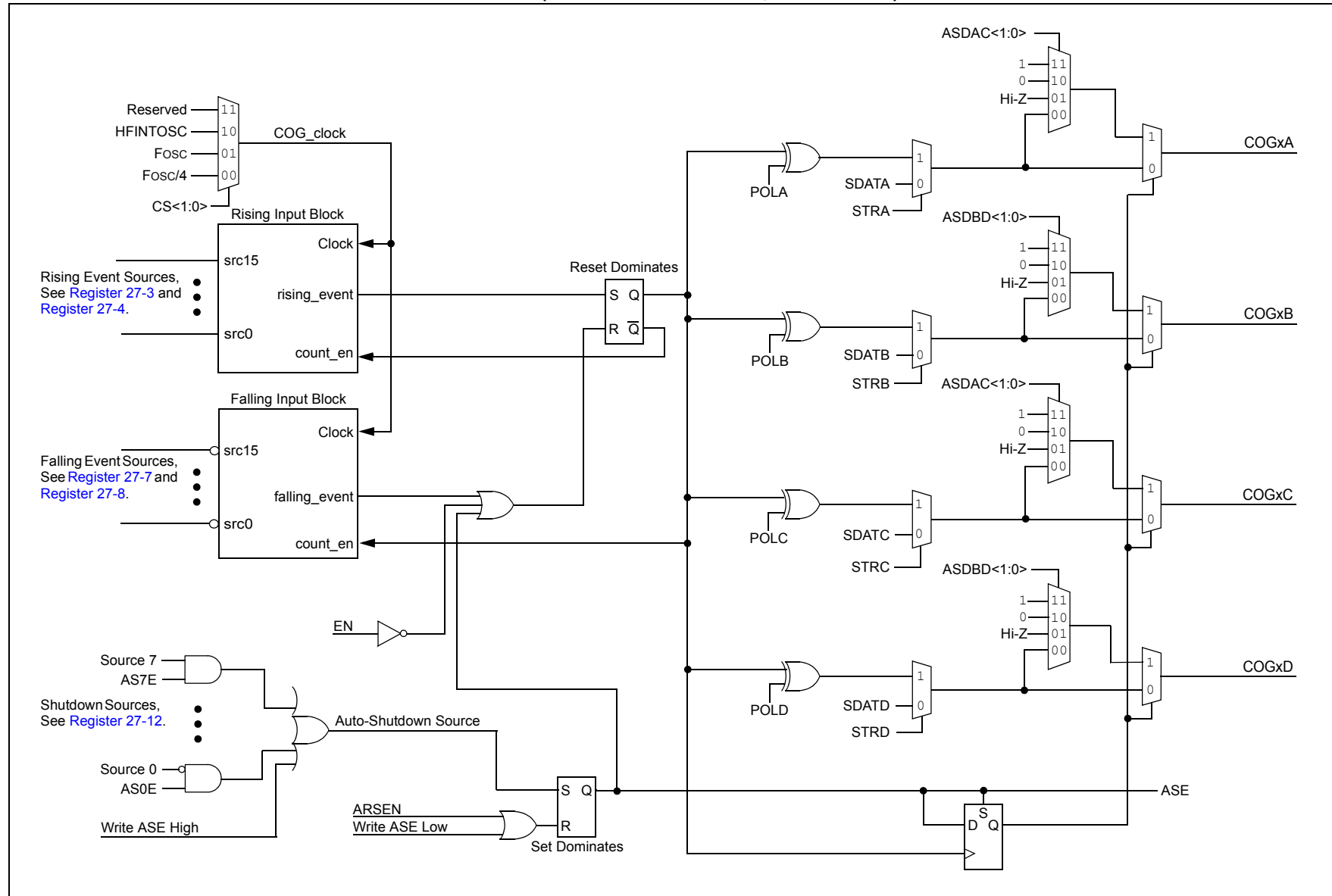
## 27.3.4 PUSH-PULL MODE

In Push-Pull mode, the COG generates a single PWM output that alternates between the two pairs of the COG outputs at every PWM period. COGxA has the same signal as COGxC. COGxB has the same signal as COGxD. The output drive activates with the rising input event and terminates with the falling event input. Each rising event starts a new period and causes the output to switch to the COG pair not used in the previous period.

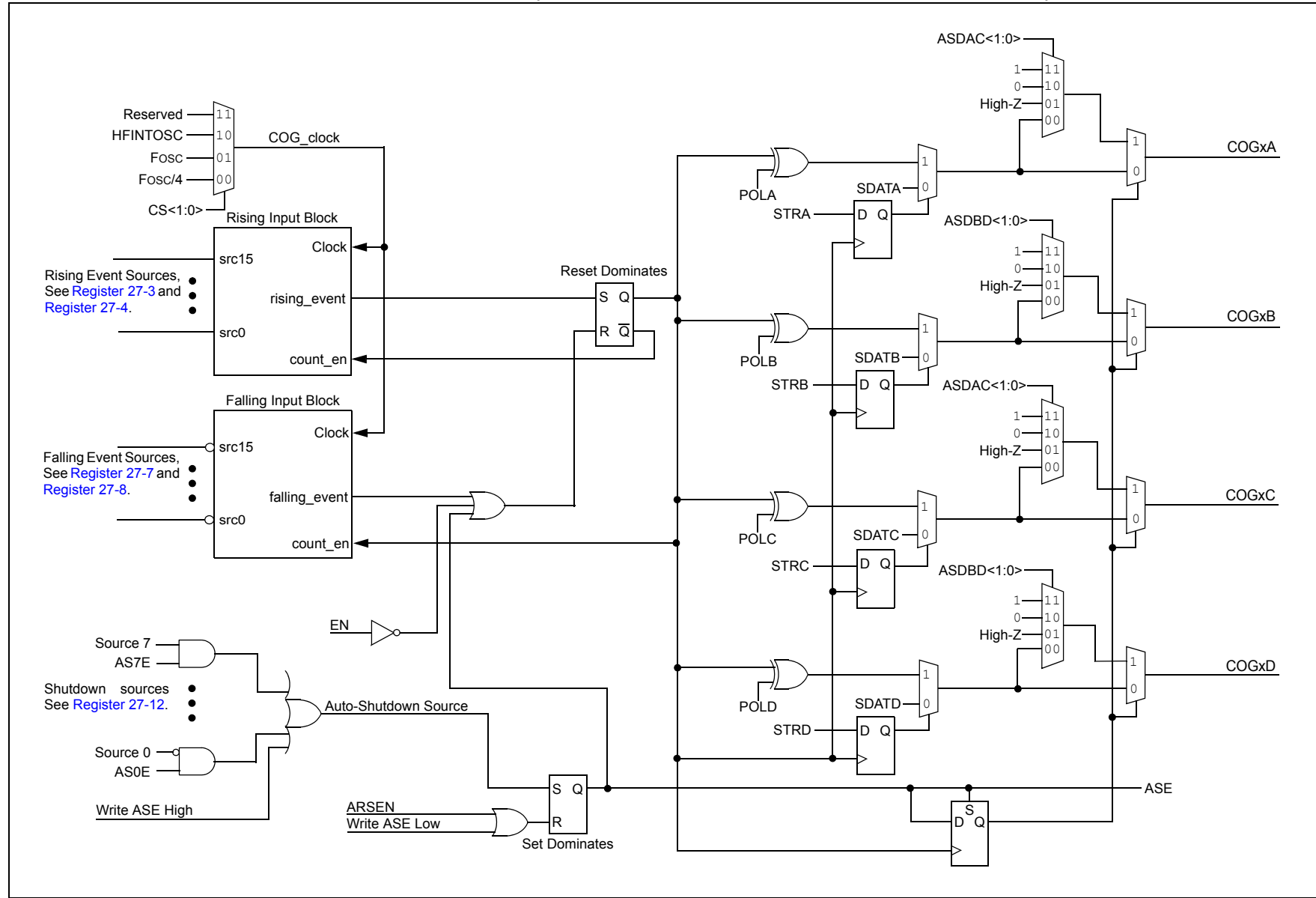
The Push-Pull mode configuration is shown in [Figure 27-6](#). A typical Push-Pull mode waveform generated from a single CCP1 input is shown in [Figure 27-11](#).

Push-Pull mode is selected by setting the MD<2:0> bits of the COGxCON0 register to '101'.

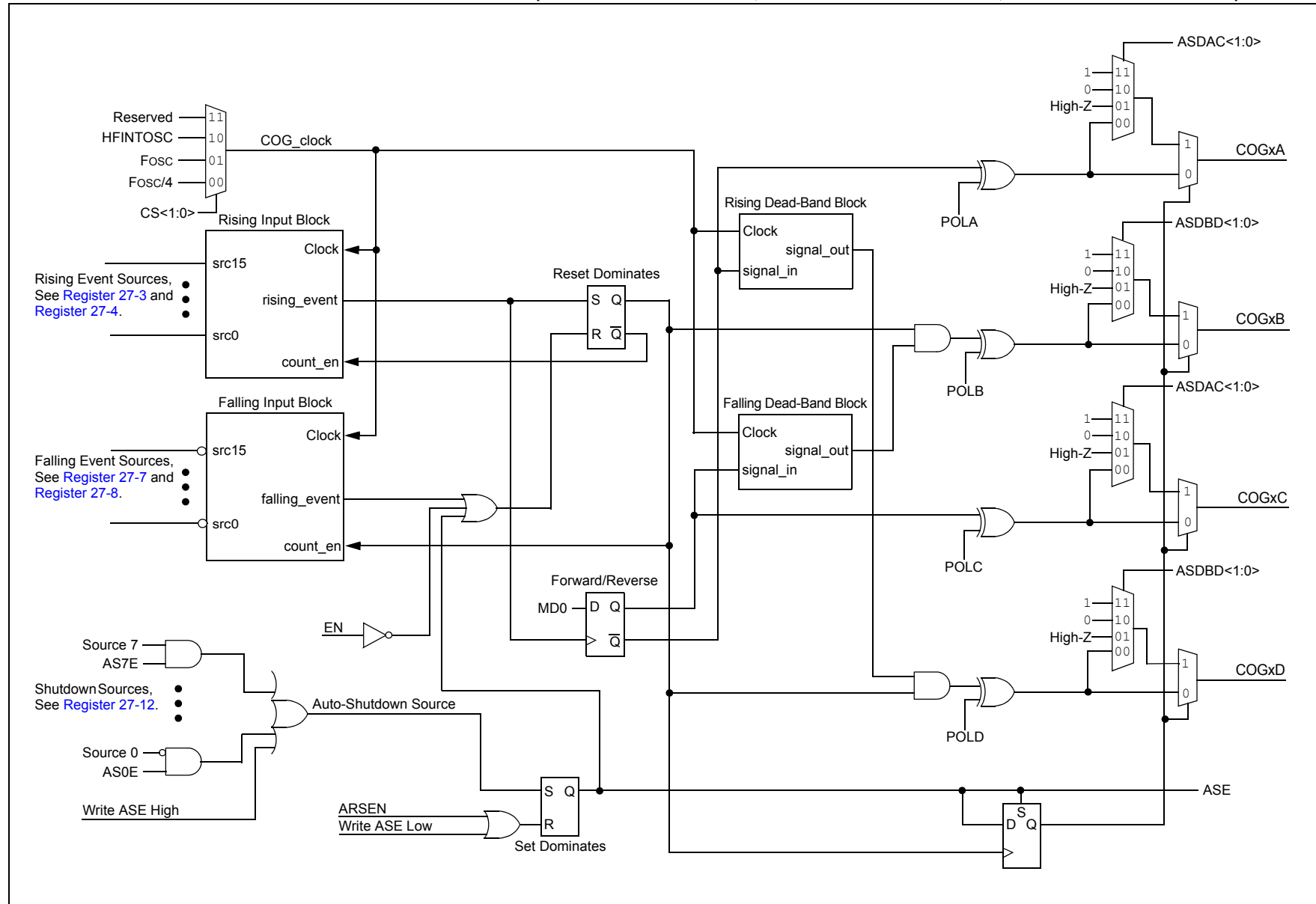
**FIGURE 27-2: SIMPLIFIED COG BLOCK DIAGRAM (STEERED PWM MODE, MD<2:0> = 0)**



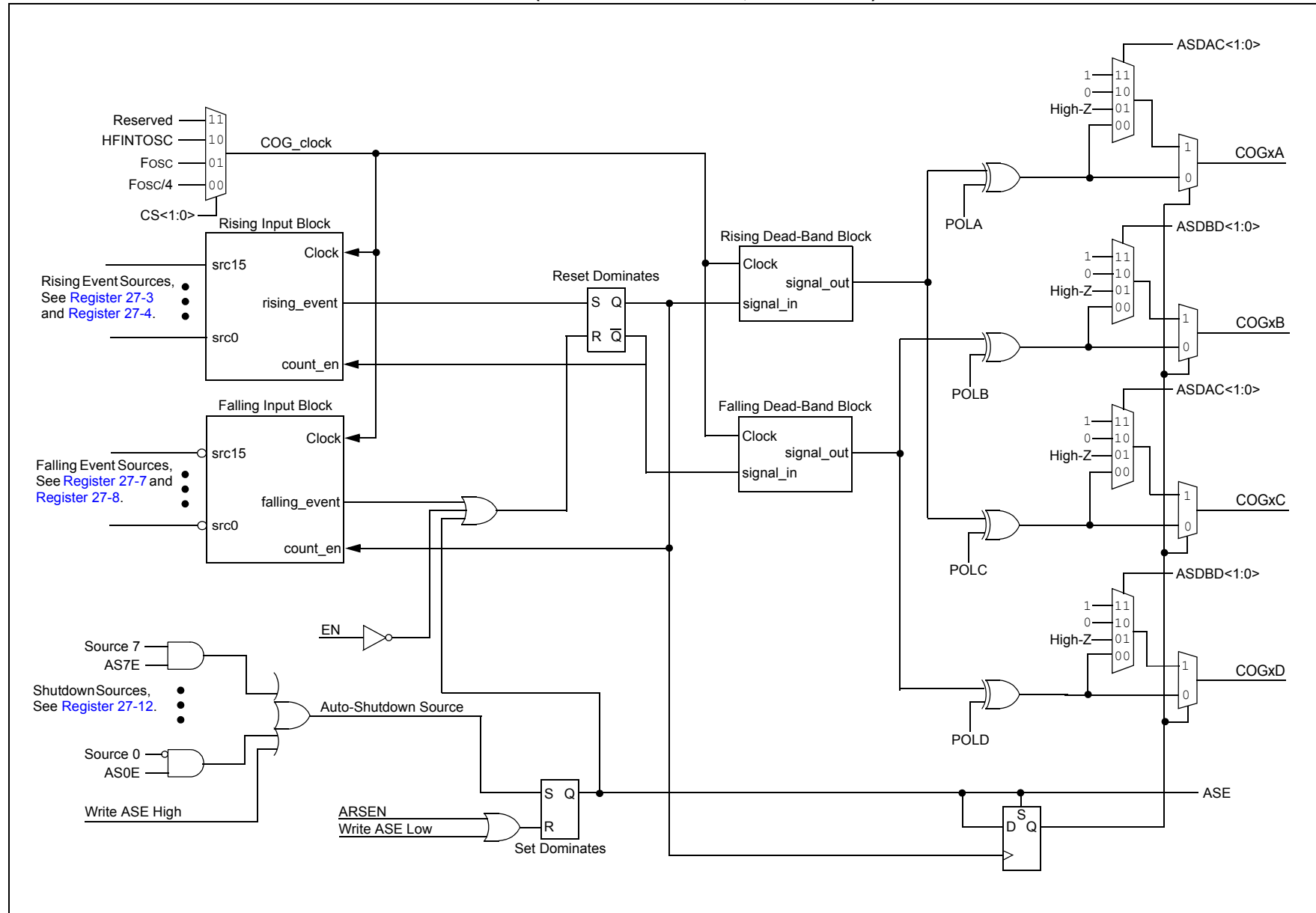
**FIGURE 27-3: SIMPLIFIED COG BLOCK DIAGRAM (SYNCHRONOUS STEERED PWM MODE, MD<2:0> = 1)**



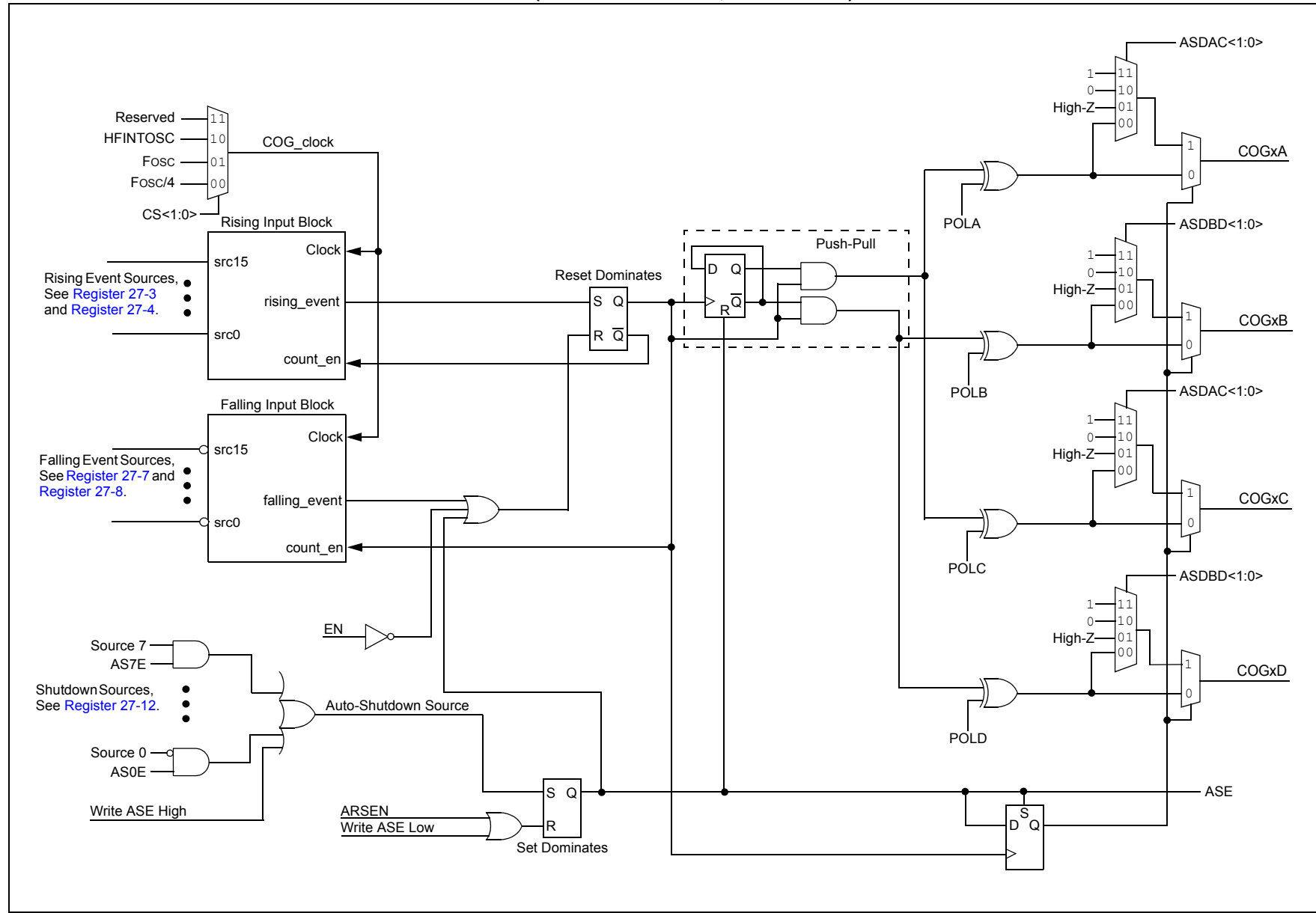
**FIGURE 27-4: SIMPLIFIED COG BLOCK DIAGRAM (FULL-BRIDGE MODES, FORWARD: MD<2:0> = 2, REVERSE: MD<2:0> = 3)**



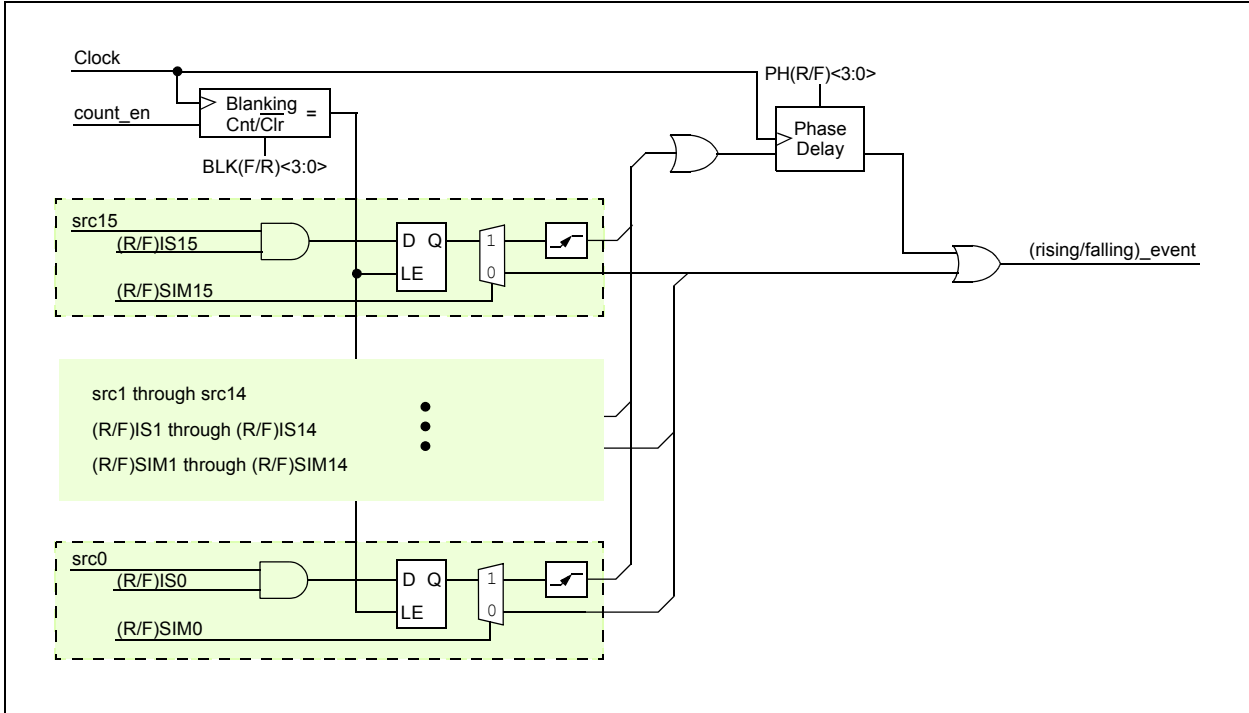
**FIGURE 27-5: SIMPLIFIED COG BLOCK DIAGRAM (HALF-BRIDGE MODE, MD<2:0> = 4)**



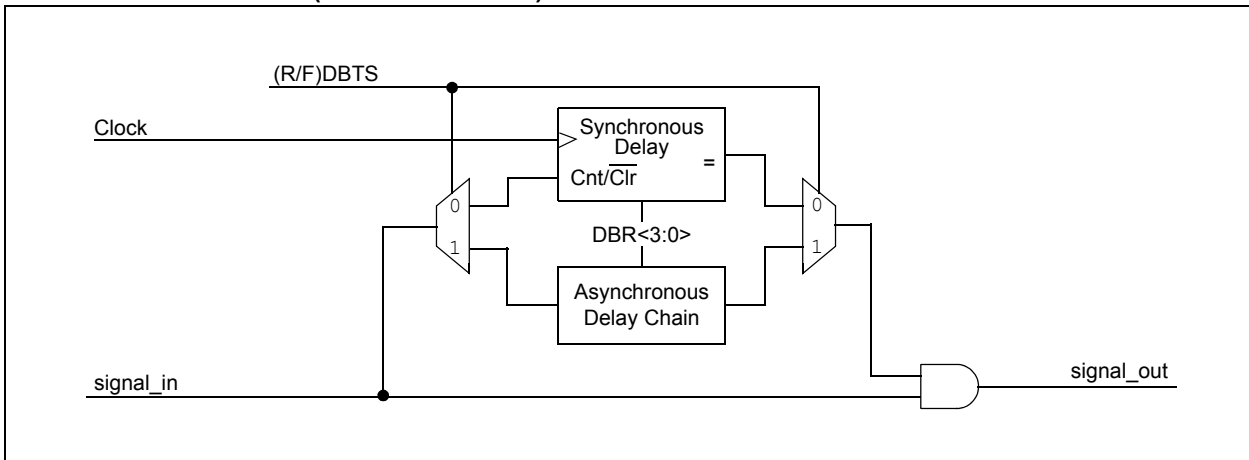
**FIGURE 27-6: SIMPLIFIED COG BLOCK DIAGRAM (PUSH-PULL MODE, MD<2:0> = 5)**



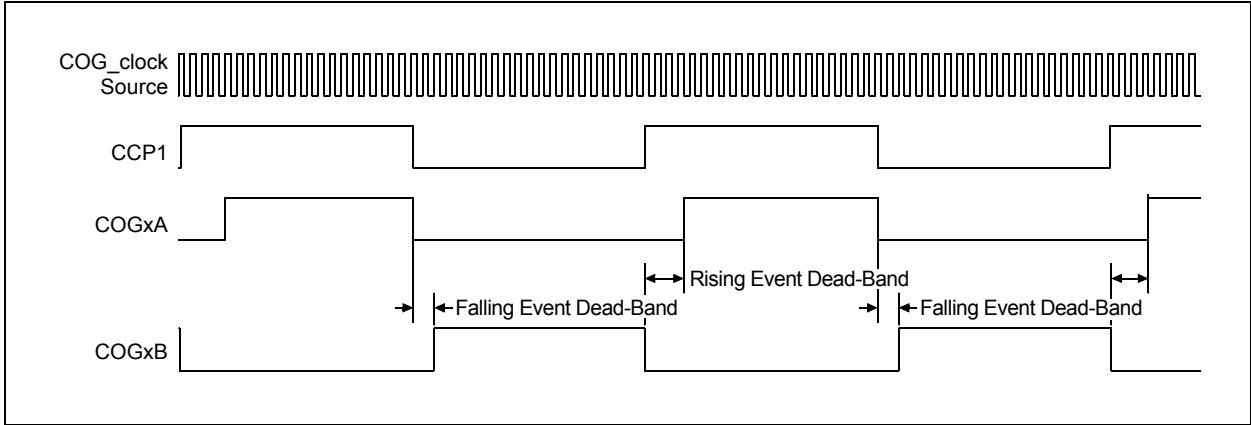
**FIGURE 27-7: COG (RISING/FALLING) INPUT BLOCK**



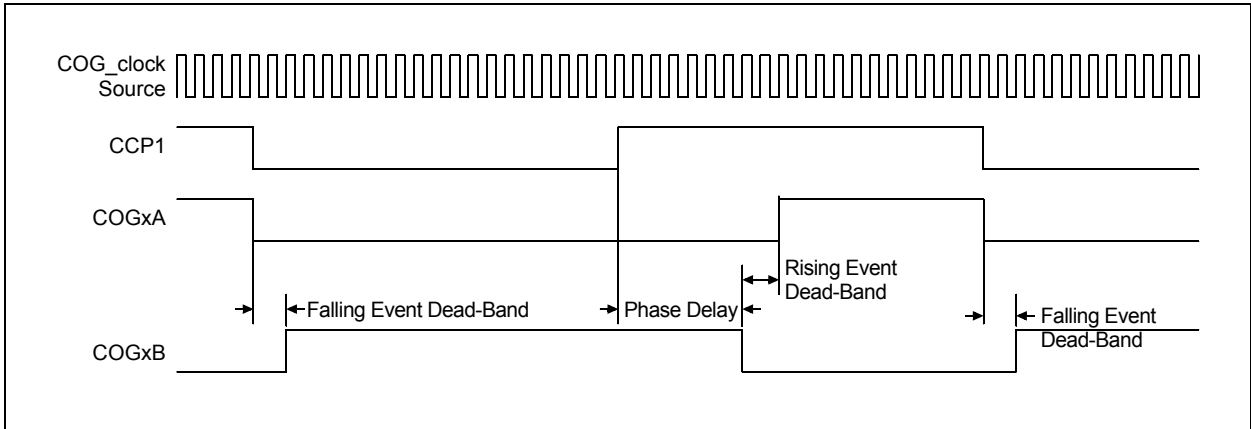
**FIGURE 27-8: COG (RISING/FALLING) DEAD-BAND BLOCK**



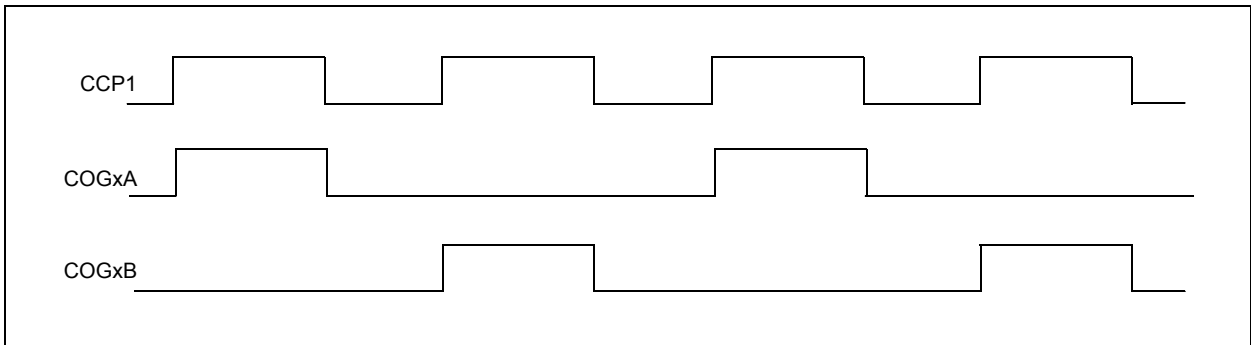
**FIGURE 27-9: TYPICAL HALF-BRIDGE MODE COG OPERATION WITH CCP1**



**FIGURE 27-10: HALF-BRIDGE MODE COG OPERATION WITH CCP1 AND PHASE DELAY**

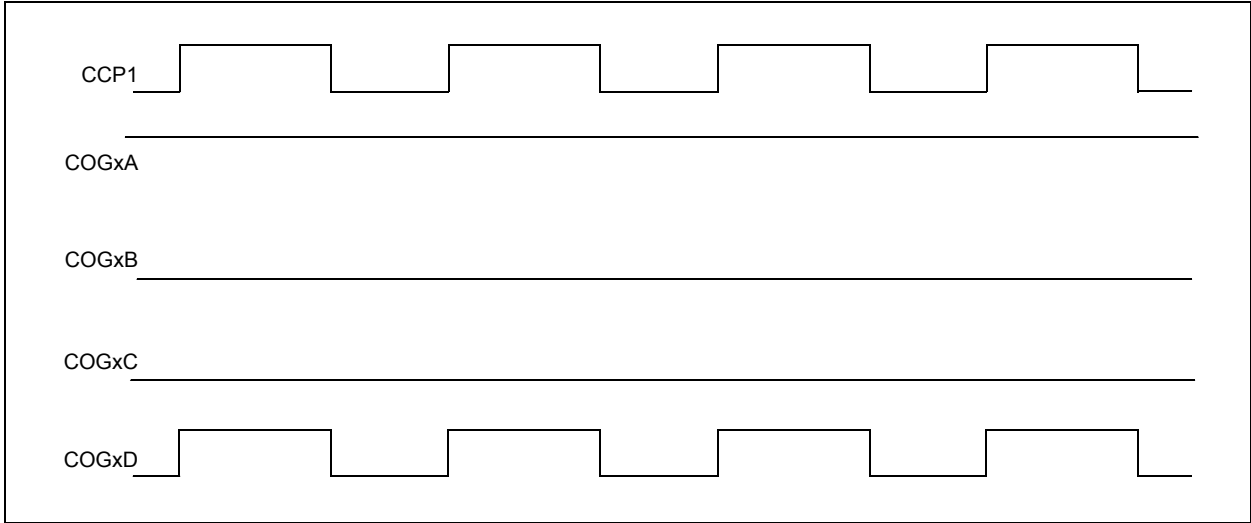


**FIGURE 27-11: PUSH-PULL MODE COG OPERATION WITH CCP1**

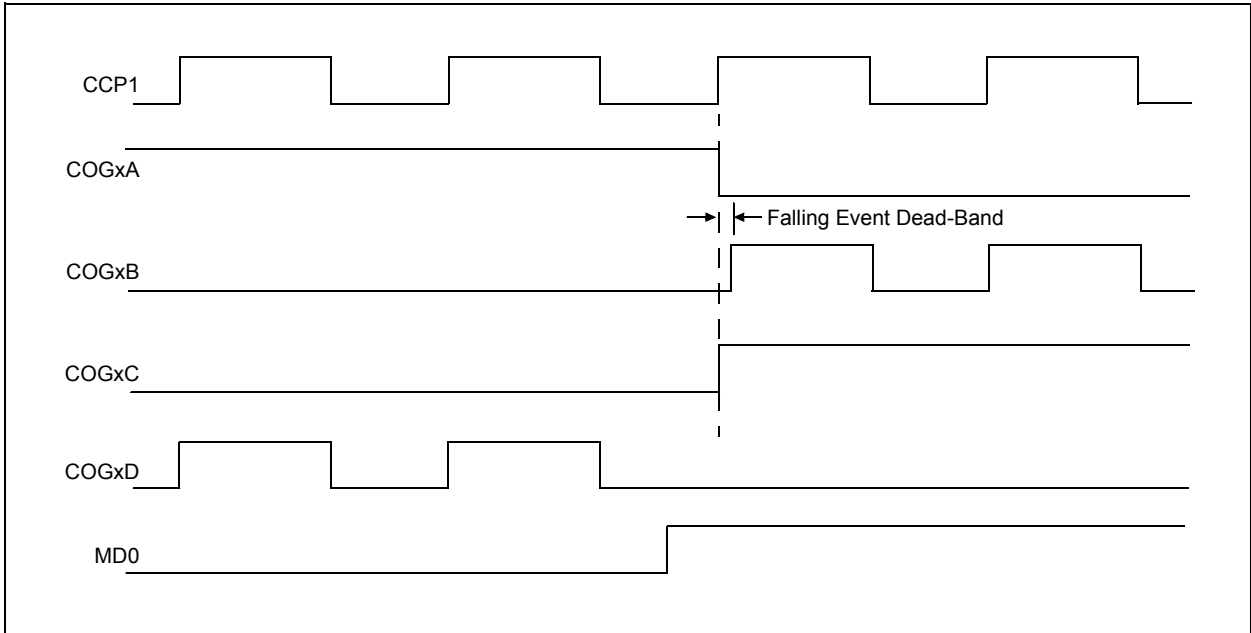




**FIGURE 27-12: FULL-BRIDGE FORWARD MODE COG OPERATION WITH CCP1**



**FIGURE 27-13: FULL-BRIDGE MODE COG OPERATION WITH CCP1 AND DIRECTION CHANGE**



## 27.4 Clock Sources

The COG\_clock is used as the reference clock to the various timers in the peripheral. Timers that use the COG\_clock include:

- Rising and falling dead-band time
- Rising and falling blanking time
- Rising and falling event phase delay

Clock sources available for selection include:

- 16 MHz HFINTOSC (active during Sleep)
- Instruction clock (FOSC/4)
- System clock (FOSC)

The clock source is selected with the CS<1:0> bits of the COGxCON0 register ([Register 27-1](#)).

## 27.5 Selectable Event Sources

The COG uses any combination of independently selectable event sources to generate the complementary waveform. Sources fall into two categories:

- Rising event sources
- Falling event sources

The rising event sources are selected by setting bits in the COGxRIS0 and COGxRIS1 registers ([Register 27-3](#) and [Register 27-4](#)). The falling event sources are selected by setting bits in the COGxFIS0 and COGxF1 registers ([Register 27-7](#) and [Register 27-8](#)). All selected sources are OR'd together to generate the corresponding event signal. Refer to [Figure 27-7](#).

### 27.5.1 EDGE vs. LEVEL SENSING

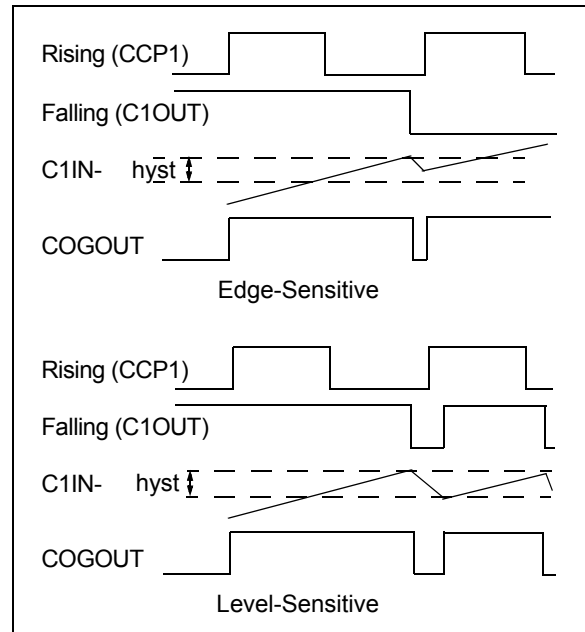
Event input detection may be selected as level or edge-sensitive. The Detection mode is individually selectable for every source. Rising Source Detection modes are selected with the COGxRSIM0 and COGxRSIM1 registers ([Register 27-5](#) and [Register 27-6](#)). Falling Source Detection modes are selected with the COGxFSIM0 and COGxFSIM1 registers ([Register 27-9](#) and [Register 27-10](#)). A set bit selects edge detection for the corresponding event source. A cleared bit selects level detection.

In general, events that are driven from a periodic source should be edge-detected and events that are derived from voltage thresholds at the target circuit should be level-sensitive. Consider the following two examples:

1. The first example is an application in which the period is determined by a 50% duty cycle clock on the rising event input and the COG output duty cycle is determined by a voltage level fed back through a comparator on the falling event input. If the clock input is level-sensitive, duty cycles less than 50% will exhibit erratic operation because the level-sensitive clock will suppress the comparator feedback.

2. The second example is similar to the first except that the duty cycle is close to 100%. The feedback comparator high-to-low transition trips the COG drive off, but almost immediately the period source turns the drive back on. If the off cycle is short enough, the comparator input may not reach the low side of the hysteresis band precluding an output change. The comparator output stays low and without a high-to-low transition to trigger the edge sense, the drive of the COG output will be stuck in a constant drive-on condition. See [Figure 27-14](#).

**FIGURE 27-14: EDGE vs. LEVEL SENSE**



## 27.5.2 RISING EVENT

The rising event starts the PWM output active duty cycle period. The rising event is the low-to-high transition of the rising\_event output. When the rising event phase delay and dead-band time values are zero, the primary output starts immediately. Otherwise, the primary output is delayed. The rising event source causes all the following actions:

- Start rising event phase delay counter (if enabled)
- Clear complementary output after phase delay
- Start falling event input blanking (if enabled)
- Start dead-band delay (if enabled)
- Set primary output after dead-band delay expires

## 27.5.3 FALLING EVENT

The falling event terminates the PWM output active duty cycle period. The falling event is the high-to-low transition of the falling\_event output. When the falling event phase delay and dead-band time values are zero, the complementary output starts immediately. Otherwise, the complementary output is delayed. The falling event source causes all the following actions:

- Start falling event phase delay counter (if enabled)
- Clear primary output
- Start rising event input blanking (if enabled)
- Start falling event dead-band delay (if enabled)
- Set complementary output after dead-band delay expires

## 27.6 Output Control

Upon disabling, or immediately after enabling the COG module, the primary COG outputs are inactive and complementary COG outputs are active.

### 27.6.1 OUTPUT ENABLES

There are no output enable controls in the COG module. Instead, each device pin has an individual output selection control called the PPS register. All four COG outputs are available for selection in the PPS register of every pin.

When a COG output is enabled by PPS selection, the output on the pin has several possibilities which depend on the mode, steering control, EN bit and shutdown state, as shown in [Table 27-1](#) and [Table 27-2](#).

**TABLE 27-1: PIN OUTPUT STATES**  
MD<2:0> = 00x

EN Bit	STR Bit	Shutdown	Output
x	0	Inactive	Static Steering Data
x	1	Active	Shutdown Override
0	1	Inactive	Inactive State
1	1	Inactive	Active PWM Signal

**TABLE 27-2: PIN OUTPUT STATES**  
MD<2:0> > 001

EN Bit	STR Bit	Shutdown	Output
x	x	Inactive	Inactive State
x	x	Active	Shutdown Override
1	x	Inactive	Active PWM Signal

### 27.6.2 POLARITY CONTROL

The polarity of each COG output can be selected independently. When the output polarity bit is set, the corresponding output is active-low. Clearing the output polarity bit configures the corresponding output as active-high. However, polarity affects the outputs in only one of the four Shutdown Override modes. See [Section 27.10 “Auto-Shutdown Control”](#) for more details.

Output polarity is selected with the POLA through POLD bits of the COGxCON1 register ([Register 27-2](#)).

## 27.7 Dead-Band Control

The dead-band control provides for non-overlapping PWM output signals to prevent shoot-through current in the external power switches. Dead-band time affects the output only in the Half-Bridge mode and when changing direction in the Full-Bridge mode.

The COG contains two dead-band timers. One dead-band timer is used for rising event dead-band control. The other is used for falling event dead-band control. Timer modes are selectable as either:

- Asynchronous delay chain
- Synchronous counter

The Dead-Band Timer mode is selected for the rising event and falling event dead-band times, with the respective RDBS and FDBS bits of the COGxCON1 register ([Register 27-2](#)).

In Half-Bridge mode, the rising event dead-band time delays all selected primary outputs from going active for the selected dead-band time after the rising event. COGxA and COGxC are the primary outputs in Half-Bridge mode.

In Half-Bridge mode, the falling event dead-band time delays all selected complementary outputs from going active for the selected dead-band time after the falling event. COGxB and COGxD are the complementary outputs in Half-Bridge mode.

In Full-Bridge mode, the dead-band delay occurs only during direction changes. The modulated output is delayed for the falling event dead-band time after a direction change from forward to reverse. The modulated output is delayed for the rising event dead-band time after a direction change from reverse to forward.

## 27.7.1 ASYNCHRONOUS DELAY CHAIN DEAD-BAND DELAY

Asynchronous dead-band delay is determined by the time it takes the input to propagate through a series of delay elements. Each delay element is a nominal five nanoseconds.

For rising event asynchronous dead-band delay, set the RDBS bit of the COGxCON0 register and set the COGxDBR register ([Register 27-14](#)) value to the desired number of delay elements in the rising event dead-band time.

For falling event asynchronous dead-band delay, set the FDBS bit of the COGxCON0 register and set the COGxDBF register ([Register 27-15](#)) value to the desired number of delay elements in the falling event dead-band time.

Setting the value to zero disables dead-band delay.

## 27.7.2 SYNCHRONOUS COUNTER DEAD-BAND DELAY

Synchronous counter dead-band is timed by counting COG\_clock periods from zero, up to the value in the Dead-Band Count register. Use [Equation 27-1](#) to calculate dead-band times.

For rising event synchronous dead-band delay, clear the RDBS bit of the COGxCON0 register and set the COGxDBR register value to the number of COG\_clock periods in the rising event dead-band time.

For falling event synchronous dead-band delay, clear the FDBS bit of the COGxCON0 register and set the COGxDBF register value to the number of COG\_clock periods in the falling event dead-band time.

When the value is zero, dead-band delay is disabled.

## 27.7.3 SYNCHRONOUS COUNTER DEAD-BAND TIME UNCERTAINTY

When the rising and falling events that trigger the dead-band counters come from asynchronous inputs, it creates uncertainty in the synchronous counter dead-band time. The maximum uncertainty is equal to one COG\_clock period. Refer to [Example 27-1](#) for more detail.

When event input sources are asynchronous with no phase delay, use the Asynchronous Delay Chain Dead-Band mode to avoid the dead-band time uncertainty.

## 27.7.4 RISING EVENT DEAD-BAND

Rising event dead-band delays the turn-on of the primary outputs from when complementary outputs are turned off. The rising event dead-band time starts when the rising\_event output goes true.

See [Section 27.7.1 “Asynchronous Delay Chain Dead-Band Delay”](#) and [Section 27.7.2 “Synchronous Counter Dead-Band Delay”](#) for more information on setting the rising edge dead-band time.

## 27.7.5 FALLING EVENT DEAD-BAND

Falling event dead-band delays the turn-on of complementary outputs from when the primary outputs are turned off. The falling event dead-band time starts when the falling\_event output goes true.

See [Section 27.7.1 “Asynchronous Delay Chain Dead-Band Delay”](#) and [Section 27.7.2 “Synchronous Counter Dead-Band Delay”](#) for more information on setting the rising edge dead-band time.

## 27.7.6 DEAD-BAND OVERLAP

There are two cases of potential dead-band overlap:

- Rising-to-falling
- Falling-to-rising

### 27.7.6.1 Rising-to-Falling Overlap

In this case, the falling event occurs while the rising event dead-band counter is still counting. When this happens, the primary drives are suppressed and the dead-band extends by the falling event dead-band time. At the termination of the extended dead-band time, the complementary drive goes true.

### 27.7.6.2 Falling-to-Rising Overlap

In this case, the rising event occurs while the falling event dead-band counter is still counting. When this happens, the complementary drive is suppressed and the dead-band extends by the rising event dead-band time. At the termination of the extended dead-band time, the primary drive goes true.

## 27.8 Blanking Control

Input blanking is a function whereby the event inputs can be masked or blanked for a short period of time. This is to prevent electrical transients caused by the turn-on/off of power components from generating a false input event.

The COG contains two blanking counters: one triggered by the rising event and the other triggered by the falling\_event. The counters are cross coupled with the events they are blanking. The falling event blanking counter is used to blank rising input events and the rising event blanking counter is used to blank falling input events. Once started, blanking extends for the time specified by the corresponding blanking counter.

Blanking is timed by counting COG\_clock periods from zero, up to the value in the Blanking Count register. Use [Equation 27-1](#) to calculate blanking times.

## 27.8.1 FALLING EVENT BLANKING OF RISING EVENT INPUTS

The falling event blanking counter inhibits rising event inputs from triggering a rising event. The falling event blanking time starts when the rising\_event output drive goes false.

The falling event blanking time is set by the value contained in the COGxBLKF register ([Register 27-17](#)). Blanking times are calculated using the formula shown in [Equation 27-1](#).

When the COGxBLKF value is zero, falling event blanking is disabled and the blanking counter output is true, thereby, allowing the event signal to pass straight through to the event trigger circuit.

## 27.8.2 RISING EVENT BLANKING OF FALLING EVENT INPUTS

The rising event blanking counter inhibits falling event inputs from triggering a falling event. The rising event blanking time starts when the falling\_event output drive goes false.

The rising event blanking time is set by the value contained in the COGxBLKR register ([Register 27-16](#)).

When the COGxBLKR value is zero, rising event blanking is disabled and the blanking counter output is true, thereby, allowing the event signal to pass straight through to the event trigger circuit.

## 27.8.3 BLANKING TIME UNCERTAINTY

When the rising and falling sources that trigger the blanking counters are asynchronous to the COG\_clock, it creates uncertainty in the blanking time. The maximum uncertainty is equal to one COG\_clock period. Refer to [Equation 27-1](#) and [Example 27-1](#) for more detail.

## 27.9 Phase Delay

It is possible to delay the assertion of either, or both, the rising event and falling events. This is accomplished by placing a non-zero value in COGxPHR or COGxPHF phase-delay count registers, respectively ([Register 27-18](#) and [Register 27-19](#)). Refer to [Figure 27-10](#) for COG operation with CCP1 and phase delay. The delay from the input rising event signal switching to the actual assertion of the events is calculated the same as the dead-band and blanking delays. Refer to [Equation 27-1](#).

When the phase-delay count value is zero, phase delay is disabled and the phase-delay counter output is true, thereby, allowing the event signal to pass straight through to the complementary output driver flop.

## 27.9.1 CUMULATIVE UNCERTAINTY

It is not possible to create more than one COG\_clock of uncertainty by successive stages. Consider that the phase-delay stage comes after the blanking stage, the dead-band stage comes after either the blanking or phase-delay stages, and the blanking stage comes after the dead-band stage. When the preceding stage is enabled, the output of that stage is necessarily synchronous with the COG\_clock, which removes any possibility of uncertainty in the succeeding stage.

### EQUATION 27-1: PHASE, DEAD-BAND AND BLANKING TIME CALCULATION

$$T_{\min} = \frac{\text{Count}}{F_{\text{COG\_clock}}}$$

$$T_{\max} = \frac{\text{Count} + 1}{F_{\text{COG\_clock}}}$$

$$T_{\text{uncertainty}} = T_{\max} - T_{\min}$$

Also:

$$T_{\text{uncertainty}} = \frac{1}{F_{\text{COG\_clock}}}$$

Where:

T	Count
Rising Phase Delay	COGxPHR
Falling Phase Delay	COGxPHF
Rising Dead Band	COGxDBR
Falling Dead Band	COGxDBF
Rising Event Blanking	COGxBLKR
Falling Event Blanking	COGxBLKF

**Note:** All inputs to the COG should be treated as asynchronous for the purpose of determining blanking, phase delay, and dead-band delay uncertainty. One clock of uncertainty may occur as a result of signal path length differences between the source signal, such as a PWM output, and the source clock, such as Fosc, even though they both use the system clock as a timing source. The uncertainty is more evident at high frequencies and high temperature.

#### Work around

When possible, choose timing source frequencies less than 20 MHz. Use the asynchronous delay chain for dead-band delay.

## EXAMPLE 27-1: TIMER UNCERTAINTY

Given:

$$Count = Ah = 10d$$

$$F_{COG\_Clock} = 8MHz$$

Therefore:

$$\begin{aligned} T_{uncertainty} &= \frac{1}{F_{COG\_clock}} \\ &= \frac{1}{8MHz} = 125ns \end{aligned}$$

Proof:

$$\begin{aligned} T_{min} &= \frac{Count}{F_{COG\_clock}} \\ &= 125ns \cdot 10d = 1.25\mu s \end{aligned}$$

$$\begin{aligned} T_{max} &= \frac{Count + 1}{F_{COG\_clock}} \\ &= 125ns \cdot (10d + 1) \\ &= 1.375\mu s \end{aligned}$$

Therefore:

$$\begin{aligned} T_{uncertainty} &= T_{max} - T_{min} \\ &= 1.375\mu s - 1.25\mu s \\ &= 125ns \end{aligned}$$

## 27.10 Auto-Shutdown Control

Auto-shutdown is a method to immediately override the COG output levels with specific overrides that allow for safe shutdown of the circuit.

The shutdown state can be either cleared automatically or held until cleared by software. In either case, the shutdown overrides remain in effect until the first rising event after the shutdown is cleared.

### 27.10.1 SHUTDOWN

The shutdown state can be entered by either of the following two mechanisms:

- Software generated
- External input

#### 27.10.1.1 Software Generated Shutdown

Setting the ASE bit of the COGxASD0 register (Register 27-11) will force the COG into the shutdown state.

When auto-restart is disabled, the shutdown state will persist until the first rising event after the ASE bit is cleared by software.

When auto-restart is enabled, the ASE bit will clear automatically and resume operation on the first rising event after the shutdown input clears. See Figure 27-15 and Section 27.10.3.2 "Auto-Restart".

#### 27.10.1.2 External Shutdown Source

External shutdown inputs provide the fastest way to safely suspend COG operation in the event of a Fault condition. When any of the selected shutdown inputs go true, the output drive latches are reset and the COG outputs immediately go to the selected override levels without software delay.

Any combination of the input sources can be selected to cause a shutdown condition. Shutdown occurs when the selected source is low. Shutdown input sources include:

- Any input pin selected with the COGxINPPS control
- Comparator 1
- Comparator 2
- Comparator 3
- Comparator 4
- CLC2 output
- Timer2 output
- Timer4 output

Shutdown inputs are selected independently with bits of the COGxASD1 register (Register 27-12).

**Note:** Shutdown inputs are level-sensitive, not edge-sensitive. The shutdown state cannot be cleared as long as the shutdown input level persists, except by disabling auto-shutdown,

#### 27.10.2 PIN OVERRIDE LEVELS

The levels driven to the output pins, while the shutdown is active, are controlled by the ASDAC<1:0> and ASDBC<1:0> bits of the COGxASD0 register (Register 27-11). ASDAC<1:0> controls the COGxA and COGxC override levels, and ASDBC<1:0> controls the COGxB and COGxD override levels. There are four override options for each output pair:

- Forced low
- Forced high
- Tri-state
- PWM inactive state (same state as that caused by a falling event)

**Note:** The polarity control does not apply to the forced low and high override levels but does apply to the PWM inactive state.

## 27.10.3 AUTO-SHUTDOWN RESTART

After an auto-shutdown event has occurred, there are two ways to resume operation:

- Software controlled
- Auto-restart

The restart method is selected with the ARSEN bit of the COGxASD0 register. Waveforms of a software controlled automatic restart are shown in [Figure 27-15](#).

### 27.10.3.1 Software Controlled Restart

When the ARSEN bit of the COGxASD0 register is cleared, software must clear the ASE bit to restart COG operation after an auto-shutdown event.

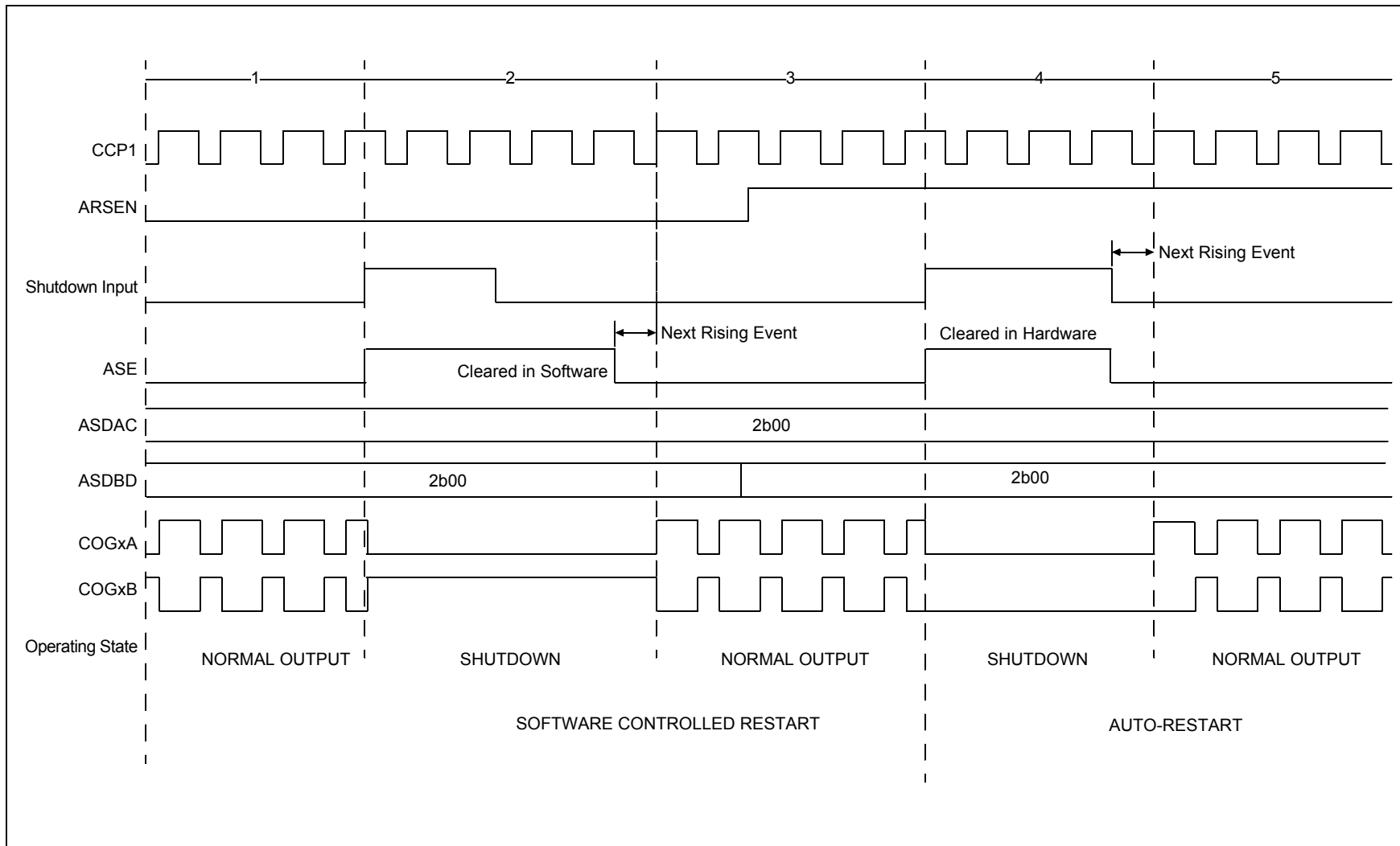
The COG will resume operation on the first rising event after the ASE bit is cleared. Clearing the shutdown state requires all selected shutdown inputs to be false; otherwise, the ASE bit will remain set.

### 27.10.3.2 Auto-Restart

When the ARSEN bit of the COGxASD0 register is set, the COG will restart from the auto-shutdown state automatically.

The ASE bit will clear automatically and the COG will resume operation on the first rising event after all selected shutdown inputs go false.

**FIGURE 27-15: AUTO-SHUTDOWN WAVEFORM – CCP1 AS RISING AND FALLING EVENT INPUT SOURCE**





## 27.11 Buffer Updates

Changes to the Phase, Dead-Band and Blanking Count registers need to occur simultaneously during COG operation to avoid unintended operation that may occur as a result of delays between each register write. This is accomplished with the LD bit of the COGxCON0 register and double-buffering of the Phase, Blanking and Dead-Band Count registers.

Before the COG module is enabled, writing the Count registers loads the count buffers without need of the LD bit. However, when the COG is enabled, the count buffer updates are suspended after writing the Count registers until after the LD bit is set. When the LD bit is set, the Phase, Dead-Band and Blanking register values are transferred to the corresponding buffers synchronous with COG operation. The LD bit is cleared by hardware when the transfer is complete.

## 27.12 Input and Output Pin Selection

The COG has one selection for an input from a device pin. That one input can be used as rising and falling event source or a Fault source. The COGxINPPS register is used to select the pin. Refer to registers, xxxPPS ([Register 12-1](#)) and RxyPPS ([Register 12-2](#)).

The Pin PPS Control registers are used to enable the COG outputs. Any combination of outputs to pins is possible including multiple pins for the same output. See the RxyPPS control register and [Section 12.2 “PPS Outputs”](#) for more details.

## 27.13 Operation During Sleep

The COG continues to operate in Sleep provided that the COG\_clock, rising event, and falling event sources remain active.

The HFINTSOC remains active during Sleep when the COG is enabled and the HFINTOSC is selected as the COG\_clock source.

## 27.14 Configuring the COG

The following steps illustrate how to properly configure the COG to ensure a synchronous start with the rising event input:

1. If a pin is to be used for the COG Fault or event input, use the COGxINPPS register to configure the desired pin.
2. Clear all ANSELx register bits associated with pins that are used for COG functions.
3. Ensure that the TRISx control bits corresponding to the COG outputs to be used are set so that all are configured as inputs. The COG module will enable the output drivers as needed later.
4. Clear the EN bit, if not already cleared.
5. Set desired dead-band times with the COGxDBR and COGxDBF registers, and select the source with the RDBS and FDBS bits of the COGxCON1 register.
6. Set desired blanking times with the COGxBLKR and COGxBLKF registers.
7. Set desired phase delay with the COGxPHR and COGxPHF registers.
8. Select the desired shutdown sources with the COGxASD1 register.
9. Setup the following controls in the COGxASD0 Auto-Shutdown register:
  - Select both output override controls to the desired levels (this is necessary, even if not using auto-shutdown because start-up will be from a shutdown state).
  - Set the ASE bit and clear the ARSEN bit.
10. Select the desired rising and falling event sources with the COGxRIS0, COGxRIS1, COGxFIS0 and COGxFIS1 registers.
11. Select the desired Rising and Falling Event modes with the COGxRSIM0, COGxRSIM1, COGxFSIM0 and COGxFSIM1 registers.
12. Configure the following controls in the COGxCON1 register:
  - Set the polarity for each output
  - Select the desired dead-band timing sources
13. Configure the following controls in the COGxCON0 register:
  - Set the desired operating mode
  - Select the desired clock source
14. If one of the Steering modes is selected, then configure the following controls in the COGxSTR register:
  - Set the steering bits of the outputs to be used.
  - Set the desired static levels.
15. Set the EN bit.
16. Set the pin PPS controls to direct the COG outputs to the desired pins.
17. If auto-restart is to be used, set the ARSEN bit and the ASE will be cleared automatically; otherwise, clear the ASE bit to start the COG.

## 27.15 Register Definitions: COG Control

Long bit name prefixes for the COG peripherals are shown in [Table 27-3](#). Refer to [Section 1.1 “Register and Bit Naming Conventions”](#) for more information.

**TABLE 27-3: BIT NAME PREFIXES**

Peripheral	Bit Name Prefix
COG1	G1
COG2 <sup>(1)</sup>	G2

**Note 1:** PIC16(L)F1768/9 devices only.

### REGISTER 27-1: COG<sub>x</sub>CON0: COG<sub>x</sub> CONTROL REGISTER 0

R/W-0/0	R/W-0/0	U-0	R/W-0/0	R/W-0/0	R/W-0/0	R/W-0/0	R/W-0/0
EN	LD	—	CS<1:0>		MD<2:0>		
bit 7							bit 0

**Legend:**

R = Readable bit	W = Writable bit	
u = Bit is unchanged	x = Bit is unknown	U = Unimplemented bit, read as '0'
'1' = Bit is set	'0' = Bit is cleared	-n/n = Value at POR and BOR/Value at all other Resets

- bit 7      **EN:** COG<sub>x</sub> Enable bit  
           1 = Module is enabled  
           0 = Module is disabled
- bit 6      **LD:** COG<sub>x</sub> Load Buffers bit  
           1 = Phase, blanking and dead-band buffers to be loaded with register values on next input events  
           0 = Register to buffer transfer is complete
- bit 5      **Unimplemented:** Read as '0'
- bit 4-3    **CS<1:0>:** COG<sub>x</sub> Clock Selection bits  
           11 = Reserved; do not use  
           10 = COG<sub>x</sub> clock is HFINTOSC (stays active during Sleep)  
           01 = COG<sub>x</sub> clock is Fosc  
           00 = COG<sub>x</sub> clock is Fosc/4
- bit 2-0    **MD<2:0>:** COG<sub>x</sub> Mode Selection bits  
           11x = Reserved; do not use  
           101 = COG outputs operate in Push-Pull mode  
           100 = COG outputs operate in Half-Bridge mode  
           011 = COG outputs operate in Reverse Full-Bridge mode  
           010 = COG outputs operate in Forward Full-Bridge mode  
           001 = COG outputs operate in Synchronous Steered PWM mode  
           000 = COG outputs operate in Steered PWM mode

## REGISTER 27-2: COGxCON1: COGx CONTROL REGISTER 1

R/W-0/0	R/W-0/0	U-0	U-0	R/W-0/0	R/W-0/0	R/W-0/0	R/W-0/0
RDBS	FDBS	—	—	POLD	POLC	POLB	POLA
bit 7							bit 0

### Legend:

R = Readable bit

W = Writable bit

u = Bit is unchanged

x = Bit is unknown

U = Unimplemented bit, read as '0'

'1' = Bit is set

'0' = Bit is cleared

-n/n = Value at POR and BOR/Value at all other Resets

- bit 7      **RDBS:** COGx Rising Event Dead-Band Timing Source Select bit  
1 = Delay chain and COGxDBR are used for dead-band timing generation  
0 = COGx\_clock and COGxDBR are used for dead-band timing generation
- bit 6      **FDBS:** COGx Falling Event Dead-band Timing Source select bit  
1 = Delay chain and COGxDBF are used for dead-band timing generation  
0 = COGx\_clock and COGxDBF are used for dead-band timing generation
- bit 5-4    **Unimplemented:** Read as '0'
- bit 3      **POLD:** COGxD Output Polarity Control bit  
1 = Active level of COGxD output is low  
0 = Active level of COGxD output is high
- bit 2      **POLC:** COGxC Output Polarity Control bit  
1 = Active level of COGxC output is low  
0 = Active level of COGxC output is high
- bit 1      **POLB:** COGxB Output Polarity Control bit  
1 = Active level of COGxB output is low  
0 = Active level of COGxB output is high
- bit 0      **POLA:** COGxA Output Polarity Control bit  
1 = Active level of COGxA output is low  
0 = Active level of COGxA output is high

## REGISTER 27-3: COGxRIS0: COGx RISING EVENT INPUT SELECTION REGISTER 0

R/W-0/0	R/W-0/0	R/W-0/0	R/W-0/0	R/W-0/0	R/W-0/0	R/W-0/0	R/W-0/0
RIS7	RIS6	RIS5	RIS4	RIS3	RIS2	RIS1	RIS0
bit 7							bit 0

### Legend:

R = Readable bit	W = Writable bit	
u = Bit is unchanged	x = Bit is unknown	U = Unimplemented bit, read as '0'
'1' = Bit is set	'0' = Bit is cleared	-n/n = Value at POR and BOR/Value at all other Resets

- bit 7      **RIS7:** COGx Rising Event Input Source 7 Enable bit  
1 = PWM3 output is enabled as a rising event input  
0 = PWM3 output has no effect on the rising event
- bit 6      **RIS6:** COGx Rising Event Input Source 6 Enable bit  
1 = CCP2 output is enabled as a rising event input  
0 = CCP2 output has no effect on the rising event
- bit 5      **RIS5:** COGx Rising Event Input Source 5 Enable bit  
1 = CCP1 output is enabled as a rising event input  
0 = CCP1 output has no effect on the rising event
- bit 4      **RIS4:** COGx Rising Event Input Source 4 Enable bit  
1 = Comparator 4 output is enabled as a rising event input  
0 = Comparator 4 output has no effect on the rising event
- bit 3      **RIS3:** COGx Rising Event Input Source 3 Enable bit  
1 = Comparator 3 output is enabled as a rising event input  
0 = Comparator 3 output has no effect on the rising event
- bit 2      **RIS2:** COGx Rising Event Input Source 2 Enable bit  
1 = Comparator 2 output is enabled as a rising event input  
0 = Comparator 2 output has no effect on the rising event
- bit 1      **RIS1:** COGx Rising Event Input Source 1 Enable bit  
1 = Comparator 1 output is enabled as a rising event input  
0 = Comparator 1 output has no effect on the rising event
- bit 0      **RIS0:** COGx Rising Event Input Source 0 Enable bit  
1 = Pin selected with COGxINPPS register is enabled as rising event input  
0 = Pin selected with COGxINPPS register has no effect on the rising event

## REGISTER 27-4: COGxRIS1: COGx RISING EVENT INPUT SELECTION REGISTER 1

R/W-0/0	R/W-0/0	R/W-0/0	R/W-0/0	R/W-0/0	R/W-0/0	R/W-0/0	R/W-0/0
RIS15 <sup>(1)</sup>	RIS14	RIS13	RIS12	RIS11	RIS10	RIS9	RIS8
bit 7							bit 0

### Legend:

R = Readable bit

W = Writable bit

u = Bit is unchanged

x = Bit is unknown

U = Unimplemented bit, read as '0'

'1' = Bit is set

'0' = Bit is cleared

-n/n = Value at POR and BOR/Value at all other Resets

- bit 7      **RIS15:** COGx Rising Event Input Source 15 Enable bit<sup>(1)</sup>  
 1 = DSM2 MD2\_out is enabled as a rising event input  
 0 = DSM2 MD2\_out has no effect on the rising event
- bit 6      **RIS14:** COGx Rising Event Input Source 14 Enable bit  
 1 = DSM1 MD1\_out output is enabled as a rising event input  
 0 = DSM1 MD1\_out has no effect on the rising event
- bit 5      **RIS13:** COGx Rising Event Input Source 13 Enable bit  
 1 = CLC3 output is enabled as a rising event input  
 0 = CLC3 output has no effect on the rising event
- bit 4      **RIS12:** COGx Rising Event Input Source 12 Enable bit  
 1 = CLC2 output is enabled as a rising event input  
 0 = CLC2 output has no effect on the rising event
- bit 3      **RIS11:** COGx Rising Event Input Source 11 Enable bit  
 1 = CLC1 output is enabled as a rising event input  
 0 = CLC1 output has no effect on the rising event
- bit 2      **RIS10:** COGx Rising Event Input Source 10 Enable bit  
 1 = PWM6 output is enabled as a rising event input  
 0 = PWM6 output has no effect on the rising event
- bit 1      **RIS9:** COGx Rising Event Input Source 9 Enable bit  
 1 = PWM5 output is enabled as a rising event input  
 0 = PWM5 output has no effect on the rising event
- bit 0      **RIS8:** COGx Rising Event Input Source 8 Enable bit  
 1 = PWM4 output is enabled as rising event input  
 0 = PWM4 output has no effect on the rising event

**Note 1:** PIC16(L)F1768/9 only. Otherwise unimplemented, read as '0'.

## REGISTER 27-5: COGxRSIM0: COGx RISING EVENT SOURCE INPUT MODE REGISTER 0

R/W-0/0	R/W-0/0	R/W-0/0	R/W-0/0	R/W-0/0	R/W-0/0	R/W-0/0	R/W-0/0
RSIM7	RSIM6	RSIM5	RSIM4	RSIM3	RSIM2	RSIM1	RSIM0
bit 7							bit 0

### Legend:

R = Readable bit	W = Writable bit	
u = Bit is unchanged	x = Bit is unknown	U = Unimplemented bit, read as '0'
'1' = Bit is set	'0' = Bit is cleared	-n/n = Value at POR and BOR/Value at all other Resets

bit 7 **RSIM7:** COGx Rising Event Input Source 7 Mode bit

RIS7 = 1:

1 = PWM3 output low-to-high transition will cause a rising event after rising event phase delay

0 = PWM3 output high level will cause an immediate rising event

RIS7 = 0:

PWM3 output has no effect on rising event.

bit 6 **RSIM6:** COGx Rising Event Input Source 6 Mode bit

RIS6 = 1:

1 = CCP2 output low-to-high transition will cause a rising event after rising event phase delay

0 = CCP2 output high level will cause an immediate rising event

RIS6 = 0:

CCP2 output has no effect on rising event.

bit 5 **RSIM5:** COGx Rising Event Input Source 5 Mode bit

RIS5 = 1:

1 = CCP1 output low-to-high transition will cause a rising event after rising event phase delay

0 = CCP1 output high level will cause an immediate rising event

RIS5 = 0:

CCP1 output has no effect on rising event.

bit 4 **RSIM4:** COGx Rising Event Input Source 4 Mode bit

RIS4 = 1:

1 = Comparator 4 output low-to-high transition will cause a rising event after rising event phase delay

0 = Comparator 4 output high level will cause an immediate rising event

RIS4 = 0:

Comparator 4 has no effect on rising event.

bit 3 **RSIM3:** COGx Rising Event Input Source 3 Mode bit

RIS3 = 1:

1 = Comparator 3 output low-to-high transition will cause a rising event after rising event phase delay

0 = Comparator 3 output high level will cause an immediate rising event

RIS3 = 0:

Comparator 3 output has no effect on rising event.

bit 2 **RSIM2:** COGx Rising Event Input Source 2 Mode bit

RIS2 = 1:

1 = Comparator 2 output low-to-high transition will cause a rising event after rising event phase delay

0 = Comparator 2 output high level will cause an immediate rising event

RIS2 = 0:

Comparator 2 has no effect on rising event.

## REGISTER 27-5: COGxRSIM0: COGx RISING EVENT SOURCE INPUT MODE REGISTER 0 (CONTINUED)

- bit 1      **RSIM1:** COGx Rising Event Input Source 1 Mode bit  
RIS1 = 1:  
1 = Comparator 1 low-to-high transition will cause a rising event after rising event phase delay  
0 = Comparator 1 high level will cause an immediate rising event  
RIS1 = 0:  
Comparator 1 has no effect on rising event.
- bit 0      **RSIM0:** COGx Rising Event Input Source 0 Mode bit  
RIS0 = 1:  
1 = Pin selected with COGxINPPS register low-to-high transition will cause a rising event after rising event phase delay  
0 = Pin selected with COGxINPPS register high level will cause an immediate rising event  
RIS0 = 0:  
Pin selected with COGxINPPS register has no effect on rising event.

# PIC16(L)F1764/5/8/9

## REGISTER 27-6: COGxRSIM1: COGx RISING EVENT SOURCE INPUT MODE REGISTER 1

R/W-0/0	R/W-0/0	R/W-0/0	R/W-0/0	R/W-0/0	R/W-0/0	R/W-0/0	R/W-0/0
RSIM15 <sup>(1)</sup>	RSIM14	RSIM13	RSIM12	RSIM11	RSIM10	RSIM9	RSIM8
bit 7							bit 0

### Legend:

R = Readable bit

W = Writable bit

u = Bit is unchanged

x = Bit is unknown

U = Unimplemented bit, read as '0'

'1' = Bit is set

'0' = Bit is cleared

-n/n = Value at POR and BOR/Value at all other Resets

- bit 7      **RSIM15:** COGx Rising Event Input Source 15 Mode bit<sup>(1)</sup>  
 RIS15 = 1:  
 1 = DSM2 MD2\_out output low-to-high transition will cause a rising event after rising event phase delay  
 0 = DSM2 MD2\_out output high level will cause an immediate rising event  
RIS15 = 0:  
 DSM2 MD2\_out output has no effect on rising event.
- bit 6      **RSIM14:** COGx Rising Event Input Source 14 Mode bit  
 RIS14 = 1:  
 1 = DSM1 MD1\_out output low-to-high transition will cause a rising event after rising event phase delay  
 0 = DSM1 MD1\_out output high level will cause an immediate rising event  
RIS14 = 0:  
 DSM1 MD1\_out output has no effect on rising event.
- bit 7-6    **Unimplemented:** Read as '0'
- bit 5      **RSIM13:** COGx Rising Event Input Source 13 Mode bit  
 RIS13 = 1:  
 1 = CLC3 output low-to-high transition will cause a rising event after rising event phase delay  
 0 = CLC3 output high level will cause an immediate rising event  
RIS13 = 0:  
 CLC3 output has no effect on rising event.
- bit 4      **RSIM12:** COGx Rising Event Input Source 12 Mode bit  
 RIS12 = 1:  
 1 = CLC2 output low-to-high transition will cause a rising event after rising event phase delay  
 0 = CLC2 output high level will cause an immediate rising event  
RIS12 = 0:  
 CLC2 output has no effect on rising event.
- bit 3      **RSIM11:** COGx Rising Event Input Source 11 Mode bit  
 RIS11 = 1:  
 1 = CLC1 output low-to-high transition will cause a rising event after rising event phase delay  
 0 = CLC1 output high level will cause an immediate rising event  
RIS11 = 0:  
 CLC1 output has no effect on rising event.
- bit 2      **RSIM10:** COGx Rising Event Input Source 10 Mode bit  
 RIS10 = 1:  
 1 = PWM6 output low-to-high transition will cause a rising event after rising event phase delay  
 0 = PWM6 output high level will cause an immediate rising event  
RIS10 = 0:  
 PWM6 output has no effect on rising event.

**Note 1:** PIC16(L)F1768/9 only. Otherwise unimplemented, read as '0'.



## REGISTER 27-6: COGxRSIM1: COGx RISING EVENT SOURCE INPUT MODE REGISTER 1 (CONTINUED)

- bit 1      **RSIM9:** COGx Rising Event Input Source 9 Mode bit  
            RIS9 = 1:  
            1 = PWM5 output low-to-high transition will cause a rising event after rising event phase delay  
            0 = PWM5 output high level will cause an immediate rising event  
            RIS9 = 0:  
            PWM5 output has no effect on rising event.
- bit 0      **RSIM8:** COGx Rising Event Input Source 8 Mode bit  
            RIS8 = 1:  
            1 = PWM4 output low-to-high transition will cause a rising event after rising event phase delay  
            0 = PWM4 output high level will cause an immediate rising event  
            RIS8 = 0:  
            PWM4 output has no effect on rising event.

**Note 1:** PIC16(L)F1768/9 only. Otherwise unimplemented, read as '0'.

## REGISTER 27-7: COGxFIS0: COGx FALLING EVENT INPUT SELECTION REGISTER 0

R/W-0/0	R/W-0/0	R/W-0/0	R/W-0/0	R/W-0/0	R/W-0/0	R/W-0/0	R/W-0/0
FIS7	FIS6	FIS5	FIS4	FIS3	FIS2	FIS1	FIS0
bit 7							bit 0

### Legend:

R = Readable bit

W = Writable bit

u = Bit is unchanged

x = Bit is unknown

U = Unimplemented bit, read as '0'

'1' = Bit is set

'0' = Bit is cleared

-n/n = Value at POR and BOR/Value at all other Resets

- bit 7      **FIS7:** COGx Falling Event Input Source 7 Enable bit  
 1 = PWM3 output is enabled as a falling event input  
 0 = PWM3 output has no effect on the falling event
- bit 6      **FIS6:** COGx Falling Event Input Source 6 Enable bit  
 1 = CCP2 output is enabled as a falling event input  
 0 = CCP2 output has no effect on the falling event
- bit 5      **FIS5:** COGx Falling Event Input Source 5 Enable bit  
 1 = CCP1 output is enabled as a falling event input  
 0 = CCP1 output has no effect on the falling event
- bit 4      **FIS4:** COGx Falling Event Input Source 4 Enable bit  
 1 = Comparator 4 output is enabled as a falling event input  
 0 = Comparator 4 output has no effect on the falling event
- bit 3      **FIS3:** COGx Falling Event Input Source 3 Enable bit  
 1 = Comparator 3 output is enabled as a falling event input  
 0 = Comparator 3 output has no effect on the falling event
- bit 2      **FIS2:** COGx Falling Event Input Source 2 Enable bit  
 1 = Comparator 2 output is enabled as a falling event input  
 0 = Comparator 2 output has no effect on the falling event
- bit 1      **FIS1:** COGx Falling Event Input Source 1 Enable bit  
 1 = Comparator 1 output is enabled as a falling event input  
 0 = Comparator 1 output has no effect on the falling event
- bit 0      **FIS0:** COGx Falling Event Input Source 0 Enable bit  
 1 = Pin selected with COGxINPPS register is enabled as falling event input  
 0 = Pin selected with COGxINPPS register has no effect on the falling event

## REGISTER 27-8: COGxFIS1: COGx FALLING EVENT INPUT SELECTION REGISTER 1

R/W-0/0	R/W-0/0	R/W-0/0	R/W-0/0	R/W-0/0	R/W-0/0	R/W-0/0	R/W-0/0
FIS15 <sup>(1)</sup>	FIS14	FIS13	FIS12	FIS11	FIS10	FIS9	FIS8
bit 7							bit 0

### Legend:

R = Readable bit

W = Writable bit

u = Bit is unchanged

x = Bit is unknown

U = Unimplemented bit, read as '0'

'1' = Bit is set

'0' = Bit is cleared

-n/n = Value at POR and BOR/Value at all other Resets

- bit 7      **FIS15:** COGx Falling Event Input Source 15 Mode bit<sup>(1)</sup>  
 1 = DSM2 MD2\_out is enabled as a falling event input  
 0 = DSM2 MD2\_out has no effect on the falling event
- bit 6      **FIS14:** COGx Falling Event Input Source 14 Mode bit  
 1 = DSM1 MD1\_out is enabled as a falling event input  
 0 = DSM1 MD1\_out has no effect on the falling event
- bit 5      **FIS13:** COGx Falling Event Input Source 13 Enable bit  
 1 = CLC3 output is enabled as a falling event input  
 0 = CLC3 output has no effect on the falling event
- bit 4      **FIS12:** COGx Falling Event Input Source 12 Enable bit  
 1 = CLC2 output is enabled as a falling event input  
 0 = CLC2 output has no effect on the falling event
- bit 3      **FIS11:** COGx Falling Event Input Source 11 Enable bit  
 1 = CLC1 output is enabled as a falling event input  
 0 = CLC1 output has no effect on the falling event
- bit 2      **FIS10:** COGx Falling Event Input Source 10 Enable bit  
 1 = PWM6 output is enabled as a falling event input  
 0 = PWM6 output has no effect on the falling event
- bit 1      **FIS9:** COGx Falling Event Input Source 9 Enable bit  
 1 = PWM5 output is enabled as a falling event input  
 0 = PWM5 output has no effect on the falling event
- bit 0      **FIS8:** COGx Falling Event Input Source 8 Enable bit  
 1 = PWM4 output is enabled as falling event input  
 0 = PWM4 output has no effect on the falling event

**Note 1:** PIC16(L)F1768/9 only. Otherwise unimplemented, read as '0'.

# PIC16(L)F1764/5/8/9

## REGISTER 27-9: COGxFSIM0: COGx FALLING EVENT SOURCE INPUT MODE REGISTER 0

R/W-0/0	R/W-0/0	R/W-0/0	R/W-0/0	R/W-0/0	R/W-0/0	R/W-0/0	R/W-0/0
FSIM7	FSIM6	FSIM5	FSIM4	FSIM3	FSIM2	FSIM1	FSIM0
bit 7							bit 0

### Legend:

R = Readable bit	W = Writable bit	
u = Bit is unchanged	x = Bit is unknown	U = Unimplemented bit, read as '0'
'1' = Bit is set	'0' = Bit is cleared	-n/n = Value at POR and BOR/Value at all other Resets

- bit 7      **FSIM7:** COGx Falling Event Input Source 7 Mode bit  
FIS7 = 1:  
 1 = PWM3 output high-to-low transition will cause a falling event after falling event phase delay  
 0 = PWM3 output low level will cause an immediate falling event  
FIS7 = 0:  
 PWM3 output has no effect on falling event.
- bit 6      **FSIM6:** COGx Falling Event Input Source 6 Mode bit  
FIS6 = 1:  
 1 = CCP2 output high-to-low transition will cause a falling event after falling event phase delay  
 0 = CCP2 output low level will cause an immediate falling event  
FIS6 = 0:  
 CCP2 output has no effect on falling event.
- bit 5      **FSIM5:** COGx Falling Event Input Source 5 Mode bit  
FIS5 = 1:  
 1 = CCP1 output high-to-low transition will cause a falling event after falling event phase delay  
 0 = CCP1 output low level will cause an immediate falling event  
FIS5 = 0:  
 CCP1 output has no effect on falling event.
- bit 4      **FSIM4:** COGx Falling Event Input Source 4 Mode bit  
FIS4 = 1:  
 1 = Comparator 4 high-to-low transition will cause a falling event after falling event phase delay  
 0 = Comparator 4 low level will cause an immediate falling event  
FIS4 = 0:  
 Comparator 4 has no effect on falling event.
- bit 3      **FSIM3:** COGx Falling Event Input Source 3 Mode bit  
FIS3 = 1:  
 1 = Comparator 3 high-to-low transition will cause a falling event after falling event phase delay  
 0 = Comparator 3 low level will cause an immediate falling event  
FIS3 = 0:  
 Comparator 3 has no effect on falling event.
- bit 2      **FSIM2:** COGx Falling Event Input Source 2 Mode bit  
FIS2 = 1:  
 1 = Comparator 2 high-to-low transition will cause a falling event after falling event phase delay  
 0 = Comparator 2 low level will cause an immediate falling event  
FIS2 = 0:  
 Comparator 2 has no effect on falling event.

## REGISTER 27-9: COGxFSIM0: COGx FALLING EVENT SOURCE INPUT MODE REGISTER 0 (CONTINUED)

bit 1      **FSIM1:** COGx Falling Event Input Source 1 Mode bit

FIS1 = 1:

1 = Comparator 1 high-to-low transition will cause a falling event after falling event phase delay

0 = Comparator 1 low level will cause an immediate falling event

FIS1 = 0:

Comparator 1 has no effect on falling event.

bit 0      **FSIM0:** COGx Falling Event Input Source 0 Mode bit

FIS0 = 1:

1 = Pin selected with COGxINPPS control high-to-low transition will cause a falling event after falling event phase delay

0 = Pin selected with COGxINPPS control low level will cause an immediate falling event

FIS0 = 0:

Pin selected with COGxINPPS control has no effect on falling event.

# PIC16(L)F1764/5/8/9

## REGISTER 27-10: COGxFSIM1: COGx FALLING EVENT SOURCE INPUT MODE REGISTER 1

R/W-0/0	R/W-0/0	R/W-0/0	R/W-0/0	R/W-0/0	R/W-0/0	R/W-0/0	R/W-0/0
FSIM15 <sup>(1)</sup>	FSIM14	FSIM13	FSIM12	FSIM11	FSIM10	FSIM9	FSIM8
bit 7							bit 0

### Legend:

R = Readable bit	W = Writable bit	
u = Bit is unchanged	x = Bit is unknown	U = Unimplemented bit, read as '0'
'1' = Bit is set	'0' = Bit is cleared	-n/n = Value at POR and BOR/Value at all other Resets

- bit 7      **FSIM15:** COGx Falling Event Input Source 15 Mode bit<sup>(1)</sup>  
FIS15 = 1:  
 1 = DSM2 MD2\_out output high-to-low transition will cause a falling event after falling event phase delay  
 0 = DSM2 MD2\_out low level will cause an immediate falling event  
FIS15 = 0:  
 DSM2 MD2\_out output has no effect on falling event.
- bit 6      **FSIM14:** COGx Falling Event Input Source 14 Mode bit  
FIS14 = 1:  
 1 = DSM1 MD1\_out output high-to-low transition will cause a falling event after falling event phase delay  
 0 = DSM1 MD1\_out output low level will cause an immediate falling event  
FIS14 = 0:  
 DSM1 MD1\_out output has no effect on falling event.
- bit 5      **FSIM13:** COGx Falling Event Input Source 13 Mode bit  
FIS13 = 1:  
 1 = CLC3 output high-to-low transition will cause a falling event after falling event phase delay  
 0 = CLC3 output low level will cause an immediate falling event  
FIS13 = 0:  
 CLC3 output has no effect on falling event.
- bit 4      **FSIM12:** COGx Falling Event Input Source 12 Mode bit  
FIS12 = 1:  
 1 = CLC2 output high-to-low transition will cause a falling event after falling event phase delay  
 0 = CLC2 output low level will cause an immediate falling event  
FIS12 = 0:  
 CLC2 output has no effect on falling event.
- bit 3      **FSIM11:** COGx Falling Event Input Source 11 Mode bit  
FIS11 = 1:  
 1 = CLC1 output high-to-low transition will cause a falling event after falling event phase delay  
 0 = CLC1 output low level will cause an immediate falling event  
FIS11 = 0:  
 CLC1 output has no effect on falling event.
- bit 2      **FSIM10:** COGx Falling Event Input Source 10 Mode bit  
FIS10 = 1:  
 1 = PWM6 output high-to-low transition will cause a falling event after falling event phase delay  
 0 = PWM6 output low level will cause an immediate falling event  
FIS10 = 0:  
 Comparator 2 has no effect on falling event.

**Note 1:** PIC16(L)F1768/9 only. Otherwise unimplemented, read as '0'.

## REGISTER 27-10: COGxFSIM1: COGx FALLING EVENT SOURCE INPUT MODE REGISTER 1 (CONTINUED)

- bit 1      **FSIM9:** COGx Falling Event Input Source 9 Mode bit  
FIS9 = 1:  
1 = PWM5 output high-to-low transition will cause a falling event after falling event phase delay  
0 = PWM5 output low level will cause an immediate falling event  
FIS9 = 0:  
PWM5 output has no effect on falling event.
- bit 0      **FSIM8:** COGx Falling Event Input Source 8 Mode bit  
FIS8 = 1:  
1 = PWM4 output high-to-low transition will cause a falling event after falling event phase delay  
0 = PWM4 output low level will cause an immediate falling event  
FIS8 = 0:  
PWM4 output has no effect on falling event.

**Note 1:** PIC16(L)F1768/9 only. Otherwise unimplemented, read as '0'.

# PIC16(L)F1764/5/8/9

## REGISTER 27-11: COGxASD0: COGx AUTO-SHUTDOWN CONTROL REGISTER 0

R/W-0/0	R/W-0/0	R/W-0/0	R/W-1/1	R/W-0/0	R/W-1/1	U-0	U-0
ASE	ARSEN	ASDBD<1:0>		ASDAC<1:0>		—	—
bit 7							bit 0

### Legend:

R = Readable bit

W = Writable bit

u = Bit is unchanged

x = Bit is unknown

U = Unimplemented bit, read as '0'

'1' = Bit is set

'0' = Bit is cleared

-n/n = Value at POR and BOR/Value at all other Resets

bit 7 **ASE:** Auto-Shutdown Event Status bit

1 = COG is in the shutdown state

0 = COG is either not in the shutdown state or will exit the shutdown state on the next rising event

bit 6 **ARSEN:** Auto-Restart Enable bit

1 = Auto-restart is enabled

0 = Auto-restart is disabled

bit 5-4 **ASDBD<1:0>:** COGxB and COGxD Auto-shutdown Override Level Select bits

11 = A logic '1' is placed on COGxB and COGxD when shutdown is active

10 = A logic '0' is placed on COGxB and COGxD when shutdown is active

01 = COGxB and COGxD are tri-stated when shutdown is active

00 = The inactive state of the pin, including polarity, is placed on COGxB and COGxD when shutdown is active

bit 3-2 **ASDAC<1:0>:** COGxA and COGxC Auto-shutdown Override Level Select bits

11 = A logic '1' is placed on COGxA and COGxC when shutdown is active

10 = A logic '0' is placed on COGxA and COGxC when shutdown is active

01 = COGxA and COGxC are tri-stated when shutdown is active

00 = The inactive state of the pin, including polarity, is placed on COGxA and COGxC when shutdown is active

bit 1-0 **Unimplemented:** Read as '0'



# PIC16(L)F1764/5/8/9

## REGISTER 27-12: COGxASD1: COGx AUTO-SHUTDOWN CONTROL REGISTER 1

R/W-0/0	R/W-0/0	R/W-0/0	R/W-0/0	R/W-0/0	R/W-0/0	R/W-0/0	R/W-0/0
AS7E	AS6E	AS5E	AS4E	AS3E	AS2E	AS1E	AS0E
bit 7							bit 0

### Legend:

R = Readable bit	W = Writable bit	U = Unimplemented bit, read as '0'
u = Bit is unchanged	x = Bit is unknown	-n/n = Value at POR and BOR/Value at all other Resets
'1' = Bit is set	'0' = Bit is cleared	q = Value depends on condition

- bit 7      **AS7E:** COGx Auto-shutdown Source Enable bit 7  
1 = COGx is shutdown when Timer4\_output is high  
0 = Timer4\_output has no effect on shutdown
- bit 6      **AS6E:** COGx Auto-shutdown Source Enable bit 6  
1 = COGx is shutdown when Timer2\_output is high  
0 = Timer2\_output has no effect on shutdown
- bit 5      **AS5E:** COGx Auto-shutdown Source Enable bit 5  
1 = COGx is shutdown when CLC LC2\_out is low  
0 = CLC2 output has no effect on shutdown
- bit 4      **AS4E:** COGx Auto-shutdown Source Enable bit 4  
1 = COGx is shutdown when Comparator sync\_C4OUT is low  
0 = Comparator 4 output has no effect on shutdown
- bit 3      **AS3E:** COGx Auto-shutdown Source Enable bit 3  
1 = COGx is shutdown when Comparator sync\_C3OUT is low  
0 = Comparator 3 output has no effect on shutdown
- bit 2      **AS2E:** COGx Auto-shutdown Source Enable bit 2  
1 = COGx is shutdown when Comparator sync\_C2OUT is low  
0 = Comparator 2 output has no effect on shutdown
- bit 1      **AS1E:** COGx Auto-shutdown Source Enable bit 1  
1 = COGx is shutdown when comparator sync\_C1OUT is low  
0 = Comparator 1 output has no effect on shutdown
- bit 0      **AS0E:** COGx Auto-shutdown Source Enable bit 0  
1 = COGx is shutdown when pin selected with COGxINPPS register is low  
0 = Pin selected with COGxINPPS register has no effect on shutdown

# PIC16(L)F1764/5/8/9

## REGISTER 27-13: COGxSTR: COGx STEERING CONTROL REGISTER 1<sup>(1)</sup>

R/W-0/0	R/W-0/0	R/W-0/0	R/W-0/0	R/W-0/0	R/W-0/0	R/W-0/0	R/W-0/0
SDATD	SDATC	SDATB	SDATA	STRD	STRC	STRB	STRA
bit 7							bit 0

### Legend:

R = Readable bit

W = Writable bit

u = Bit is unchanged

x = Bit is unknown

U = Unimplemented bit, read as '0'

'1' = Bit is set

'0' = Bit is cleared

-n/n = Value at POR and BOR/Value at all other Resets

- bit 7      **SDATD:** COGxD Static Output Data bit  
 1 = COGxD static data is high  
 0 = COGxD static data is low
- bit 6      **SDATC:** COGxC Static Output Data bit  
 1 = COGxC static data is high  
 0 = COGxC static data is low
- bit 5      **SDATB:** COGxB Static Output Data bit  
 1 = COGxB static data is high  
 0 = COGxB static data is low
- bit 4      **SDATA:** COGxA Static Output Data bit  
 1 = COGxA static data is high  
 0 = COGxA static data is low
- bit 3      **STRD:** COGxD Steering Control bit  
 1 = COGxD output has the COGxD waveform with polarity control from the POLD bit  
 0 = COGxD output is the static data level determined by the SDATD bit
- bit 2      **STRC:** COGxC Steering Control bit  
 1 = COGxC output has the COGxC waveform with polarity control from the POLC bit  
 0 = COGxC output is the static data level determined by the SDATC bit
- bit 1      **STRB:** COGxB Steering Control bit  
 1 = COGxB output has the COGxB waveform with polarity control from the POLB bit  
 0 = COGxB output is the static data level determined by the SDATB bit
- bit 0      **STRA:** COGxA Steering Control bit  
 1 = COGxA output has the COGxA waveform with polarity control from the POLA bit  
 0 = COGxA output is the static data level determined by the SDATA bit

**Note 1:** Steering is active only when the MD<2:0> bits of the COGxCON0 register = 00x (see [Register 27-1](#)).

# PIC16(L)F1764/5/8/9

## REGISTER 27-14: COGxDBR: COGx RISING EVENT DEAD-BAND COUNT REGISTER

U-0	U-0	R/W-0/0	R/W-0/0	R/W-0/0	R/W-0/0	R/W-0/0	R/W-0/0
—	—	DBR<5:0>					
bit 7							bit 0

### Legend:

R = Readable bit	W = Writable bit	
u = Bit is unchanged	x = Bit is unknown	U = Unimplemented bit, read as '0'
'1' = Bit is set	'0' = Bit is cleared	-n/n = Value at POR and BOR/Value at all other Resets

bit 7-6      **Unimplemented:** Read as '0'

bit 5-0      **DBR<5:0>:** Rising Event Dead-Band Count Value bits

RDBS = 0:

= Number of COGx clock periods to delay primary output after rising event

RDBS = 1:

= Number of delay chain element periods to delay primary output after rising event

## REGISTER 27-15: COGxDBF: COGx FALLING EVENT DEAD-BAND COUNT REGISTER

U-0	U-0	R/W-0/0	R/W-0/0	R/W-0/0	R/W-0/0	R/W-0/0	R/W-0/0
		DBF<5:0>					
bit 7							bit 0

### Legend:

R = Readable bit	W = Writable bit	
u = Bit is unchanged	x = Bit is unknown	U = Unimplemented bit, read as '0'
'1' = Bit is set	'0' = Bit is cleared	-n/n = Value at POR and BOR/Value at all other Resets

bit 7-6      **Unimplemented:** Read as '0'

bit 5-0      **DBF<5:0>:** Falling Event Dead-Band Count Value bits

FDBS = 0:

= Number of COGx clock periods to delay complementary output after falling event input

FDBS = 1:

= Number of delay chain element periods to delay complementary output after falling event input

# PIC16(L)F1764/5/8/9

## REGISTER 27-16: COGxBLKR: COGx RISING EVENT BLANKING COUNT REGISTER

U-0	U-0	R/W-x/u	R/W-x/u	R/W-x/u	R/W-x/u	R/W-x/u	R/W-x/u	
		BLKR<5:0>						
bit 7								bit 0

### Legend:

R = Readable bit                      W = Writable bit  
u = Bit is unchanged                  x = Bit is unknown                  U = Unimplemented bit, read as '0'  
'1' = Bit is set                          '0' = Bit is cleared                  -n/n = Value at POR and BOR/Value at all other Resets

bit 7-6            **Unimplemented:** Read as '0'  
bit 5-0            **BLKR<5:0>:** Rising Event Blanking Count Value bits  
= Number of COGx clock periods to inhibit falling event inputs

## REGISTER 27-17: COGxBLKF: COGx FALLING EVENT BLANKING COUNT REGISTER

U-0	U-0	R/W-0/0	R/W-0/0	R/W-0/0	R/W-0/0	R/W-0/0	R/W-0/0	
		BLKF<5:0>						
bit 7								bit 0

### Legend:

R = Readable bit                      W = Writable bit  
u = Bit is unchanged                  x = Bit is unknown                  U = Unimplemented bit, read as '0'  
'1' = Bit is set                          '0' = Bit is cleared                  -n/n = Value at POR and BOR/Value at all other Resets

bit 7-6            **Unimplemented:** Read as '0'  
bit 5-0            **BLKF<5:0>:** Falling Event Blanking Count Value bits  
= Number of COGx clock periods to inhibit rising event inputs

## REGISTER 27-18: COGxPHR: COGx RISING EVENT PHASE DELAY COUNT REGISTER

U-0	U-0	R/W-0/0	R/W-0/0	R/W-0/0	R/W-0/0	R/W-0/0	R/W-0/0	
—		PHR<5:0>						
bit 7								bit 0

### Legend:

R = Readable bit                      W = Writable bit  
u = Bit is unchanged                  x = Bit is unknown                  U = Unimplemented bit, read as '0'  
'1' = Bit is set                          '0' = Bit is cleared                  -n/n = Value at POR and BOR/Value at all other Resets

bit 7-6            **Unimplemented:** Read as '0'  
bit 5-0            **PHR<5:0>:** Rising Event Phase Delay Count Value bits  
= Number of COGx clock periods to delay rising event

# PIC16(L)F1764/5/8/9

**REGISTER 27-19: COGxPHF: COGx FALLING EVENT PHASE DELAY COUNT REGISTER**

U-0	U-0	R/W-0/0	R/W-0/0	R/W-0/0	R/W-0/0	R/W-0/0	R/W-0/0
—	—	PHF<5:0>					
bit 7							bit 0

**Legend:**

R = Readable bit	W = Writable bit	
u = Bit is unchanged	x = Bit is unknown	U = Unimplemented bit, read as '0'
'1' = Bit is set	'0' = Bit is cleared	-n/n = Value at POR and BOR/Value at all other Resets

bit 7-6      **Unimplemented:** Read as '0'  
bit 5-0      **PHF<5:0>:** Falling Event Phase Delay Count Value bits  
= Number of COGx clock periods to delay falling event

**TABLE 27-4: SUMMARY OF REGISTERS ASSOCIATED WITH COGx**

Name	Bit 7	Bit 6	Bit 5	Bit 4	Bit 3	Bit 2	Bit 1	Bit 0	Register on Page
ANSELA	—	—	—	ANSA4	—	ANSA<2:0>			139
ANSELB <sup>(1)</sup>	ANSB<7:4>				—	—	—	—	145
ANSELC	ANSC<7:6> <sup>(1)</sup>			—	—	ANSC<3:0>			150
COGxASD0	ASE	ARSEN	ASDBD<1:0>		ASDAC<1:0>		—	—	328
COGxASD1	AS7E	AS6E	AS5E	AS4E	AS3E	AS2E	AS1E	AS0E	329
COGxBLKR	—	—	BLKR<5:0>						332
COGxBLKF	—	—	BLKF<5:0>						332
COGxCON0	EN	LD	—	CS<1:0>		MD<2:0>			314
COGxCON1	RDBS	FDBS	—	—	POLD	POLC	POLB	POLA	315
COGxDBR	—	—	DBR<5:0>						331
COGxDBF	—	—	DBF<5:0>						331
COGxFIS0	FIS7	FIS6	FIS5	FIS4	FIS3	FIS2	FIS1	FIS0	322
COGxFIS1	FIS15 <sup>(1)</sup>	FIS14	FIS13	FIS12	FIS11	FIS10	FIS9	FIS8	323
COGxFSIM0	FSIM7	FSIM6	FSIM5	FSIM4	FSIM3	FSIM2	FSIM1	FSIM0	324
COGxFSIM1	FSIM15 <sup>(1)</sup>	FSIM14	FSIM13	FSIM12	FSIM11	FSIM10	FSIM9	FSIM8	326
COGxPHR	—	—	PHR<5:0>						332
COGxPHF	—	—	PHF<5:0>						333
COGxPPS	—	—	—	COG1PPS<4:0>					156, 158
COGxRIS0	RIS7	RIS6	RIS5	RIS4	RIS3	RIS2	RIS1	RIS0	316
COGxRIS1	RIS15 <sup>(1)</sup>	RIS14	RIS13	RIS12	RIS11	RIS10	RIS9	RIS8	317
COGxRSIM0	RSIM7	RSIM6	RSIM5	RSIM4	RSIM3	RSIM2	RSIM1	RSIM0	318
COGxRSIM1	RSIM15 <sup>(1)</sup>	RSIM14	RSIM13	RSIM12	RSIM11	RSIM10	RSIM9	RSIM8	320
COGxSTR	SDATD	SDATC	SDATB	SDATA	STRD	STRC	STRB	STRA	330
INTCON	GIE	PEIE	TMR0IE	INTE	IOIE	TMR0IF	INTF	IOCF	101
RxyPPS	—	—	—	RxyPPS<4:0>					156

**Legend:** — = unimplemented location, read as '0'. Shaded cells are not used by COG.

**Note 1:** PIC16(L)F1768/9 only.

## 28.0 CONFIGURABLE LOGIC CELL (CLC)

The Configurable Logic Cell (CLC) provides programmable logic that operates outside the speed limitations of software execution. The logic cell takes up to 32 input signals, and through the use of configurable gates, reduces the 32 inputs to four logic lines that drive one of eight selectable single output logic functions.

Input sources are a combination of the following:

- I/O pins
- Internal clocks
- Peripherals
- Register bits

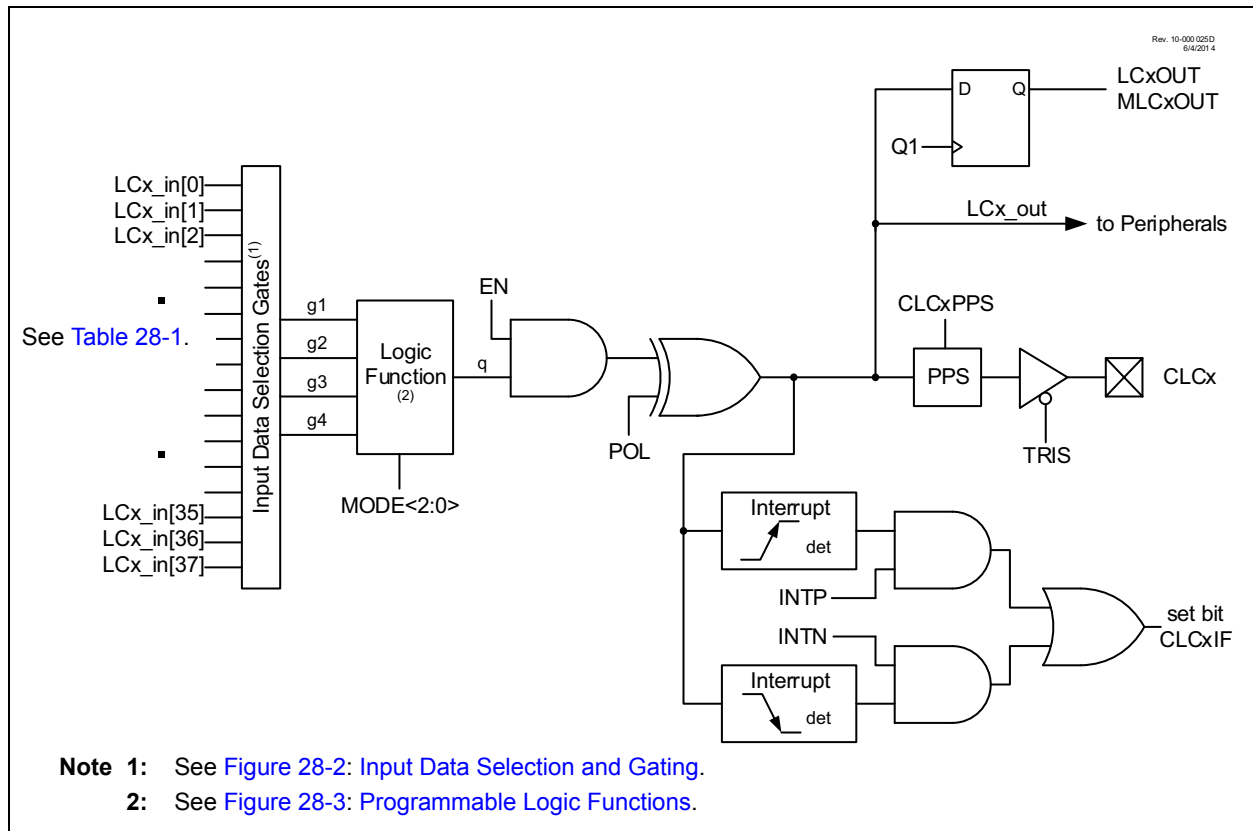
The output can be directed internally to peripherals and to an output pin.

Refer to [Figure 28-1](#) for a simplified diagram showing signal flow through the CLCx.

Possible configurations include:

- Combinatorial Logic:
  - AND
  - NAND
  - AND-OR
  - AND-OR-INVERT
  - OR-XOR
  - OR-XNOR
- Latches:
  - S-R
  - Clocked D with Set and Reset
  - Transparent D with Set and Reset
  - Clocked J-K with Reset

**FIGURE 28-1: CLCx SIMPLIFIED BLOCK DIAGRAM**



## 28.1 CLCx Setup

Programming the CLCx module is performed by configuring the four stages in the logic signal flow. The four stages are:

- Data selection
- Data gating
- Logic function selection
- Output polarity

Each stage is set up at run time by writing to the corresponding CLCx Special Function Registers. This has the added advantage of permitting logic reconfiguration on-the-fly during program execution.

### 28.1.1 DATA SELECTION

There are 32 signals available as inputs to the configurable logic. Four 32-input multiplexers are used to select the inputs to pass on to the next stage.

Data selection is through four multiplexers, as indicated on the left side of [Figure 28-2](#). Data inputs in the figure are identified by a generic numbered input name.

[Table 28-1](#) correlates the generic input name to the actual signal for each CLC module. The column labeled, *dy*, indicates the MUX selection code for the selected data input. *DxS* is an abbreviation for the MUX select input codes: D1S<5:0> through D4S<5:0>.

Data inputs are selected with the CLCxSEL0 through CLCxSEL3 registers ([Register 28-3](#) through [Register 28-6](#)).

**Note:** Data selections are undefined at power-up.

**TABLE 28-1: CLCx DATA INPUT SELECTION**

Data Input	<i>dy</i> DxS<5:0>	CLCx
LCx_in[38]	100110	MD1_out <sup>(1)</sup> or MD2_out <sup>(2)</sup> or Reserved <sup>(3)</sup>
LCx_in[37]	100101	Fosc
LCx_in[36]	100100	HFINTOSC
LCx_in[35]	100011	LFINTOSC
LCx_in[34]	100010	FRC (ADC RC clock)
LCx_in[33]	100001	IOCIF Set
LCx_in[32]	100000	Timer6_postscaled
LCx_in[31]	011111	Timer4_postscaled
LCx_in[30]	011110	Timer2_postscaled
LCx_in[29]	011101	Timer5 Overflow
LCx_in[28]	011100	Timer3 Overflow
LCx_in[27]	011011	Timer1 Overflow
LCx_in[26]	011010	Timer0 Overflow
LCx_in[25]	011001	EUSART RX
LCx_in[24]	011000	EUSART TX
LCx_in[23]	010111	ZCD1_output
LCx_in[22]	010110	MSSP1 SDO/SDA
LCx_in[21]	010101	MSSP1 SCL/SCK
LCx_in[20]	010100	PWM6_out
LCx_in[19]	010011	PWM5_out
LCx_in[18]	010010	PWM4_out
LCx_in[17]	010001	PWM3_out
LCx_in[16]	010000	CCP2_out
LCx_in[15]	001111	CCP1_out
LCx_in[14]	001110	COG2B
LCx_in[13]	001101	COG2A
LCx_in[12]	001100	COG1B
LCx_in[11]	001011	COG1A
LCx_in[10]	001010	sync_C4OUT
LCx_in[9]	001001	sync_C3OUT
LCx_in[8]	001000	sync_C2OUT
LCx_in[7]	000111	sync_C1OUT
LCx_in[6]	000110	LC3_out from the CLC3
LCx_in[5]	000101	LC2_out from the CLC2
LCx_in[4]	000100	LC1_out from the CLC1
LCx_in[3]	000011	CLCIN3 Pin Input Selected in CLCIN3PPS Register
LCx_in[2]	000010	CLCIN2 Pin Input Selected in CLCIN2PPS Register
LCx_in[1]	000001	CLCIN1 Pin Input Selected in CLCIN1PPS Register
LCx_in[0]	000000	CLCIN0 Pin Input Selected in CLCIN0PPS Register

- Note 1:** CLCxSEL0 only.  
**2:** PIC16(L)F1768/9 CLCxSEL1 only.  
**3:** CLCxSEL2, CLCxSEL3 and PIC16(L)F1764/5 CLCxSEL1 only.

## 28.1.2 DATA GATING

Outputs from the input multiplexers are directed to the desired logic function input through the data gating stage. Each data gate can direct any combination of the four selected inputs.

**Note:** Data gating is undefined at power-up.

The gate stage is more than just signal direction. The gate can be configured to direct each input signal as inverted or noninverted data. Directed signals are ANDed together in each gate. The output of each gate can be inverted before going on to the logic function stage.

The gating is, in essence, a 1-to-4 input AND/NAND/OR/NOR gate. When every input is inverted and the output is inverted, the gate is an OR of all enabled data inputs. When the inputs and output are not inverted, the gate is an AND of all enabled inputs.

Table 28-2 summarizes the basic logic that can be obtained in Gate 1 by using the gate logic select bits. The table shows the logic of four input variables, but each gate can be configured to use less than four. If no inputs are selected, the output will be zero or one, depending on the gate output polarity bit.

**TABLE 28-2: DATA GATING LOGIC**

CLCxGLS0	G1POL	Gate Logic
0x55	1	AND
0x55	0	NAND
0xAA	1	NOR
0xAA	0	OR
0x00	0	Logic '0'
0x00	1	Logic '1'

It is possible (but not recommended) to select both the true and negated values of an input. When this is done, the gate output is zero, regardless of the other inputs, but may emit logic glitches (transient-induced pulses). If the output of the channel must be zero or one, the recommended method is to set all gate bits to zero and use the gate polarity bit to set the desired level.

Data gating is configured with the Logic Gate Select registers as follows:

- Gate 1: CLCxGLS0 (Register 28-7)
- Gate 2: CLCxGLS1 (Register 28-8)
- Gate 3: CLCxGLS2 (Register 28-9)
- Gate 4: CLCxGLS3 (Register 28-10)

Register number suffixes are different than the gate numbers because other variations of this module have multiple gate selections in the same register.

Data gating is indicated in the right side of Figure 28-2. Only one gate is shown in detail. The remaining three gates are configured identically with the exception that the data enables correspond to the enables for that gate.

## 28.1.3 LOGIC FUNCTION

There are eight available logic functions including:

- AND-OR
- OR-XOR
- AND
- S-R Latch
- D Flip-Flop with Set and Reset
- D Flip-Flop with Reset
- J-K Flip-Flop with Reset
- Transparent Latch with Set and Reset

Logic functions are shown in Figure 28-3. Each logic function has four inputs and one output. The four inputs are the four data gate outputs of the previous stage. The output is fed to the inversion stage and from there to other peripherals, an output pin, and back to the CLCx itself.

## 28.1.4 OUTPUT POLARITY

The last stage in the Configurable Logic Cell is the output polarity. Setting the POL bit of the CLCxCON register inverts the output signal from the logic stage. Changing the polarity while the interrupts are enabled will cause an interrupt for the resulting output transition.



## 28.1.5 CLCx SETUP STEPS

The following steps should be followed when setting up the CLCx:

- Disable CLCx by clearing the EN bit.
- Select desired inputs using CLCxSEL0 through CLCxSEL3 registers (see [Table 28-1](#)).
- Clear any associated ANSELx bits.
- Set all TRISx bits associated with inputs.
- Clear all TRISx bits associated with outputs.
- Enable the chosen inputs through the four gates using CLCxGLS0, CLCxGLS1, CLCxGLS2, and CLCxGLS3 registers.
- Select the gate output polarities with the POLy bits of the CLCxPOL register.
- Select the desired logic function with the MODE<2:0> bits of the CLCxCON register.
- Select the desired polarity of the logic output with the POL bit of the CLCxPOL register. (This step may be combined with the previous gate output polarity step).
- If driving a device pin, set the desired Pin PPS Control register and also clear the TRISx bit corresponding to that output.
- If interrupts are desired, configure the following bits:
  - Set the INTP bit in the CLCxCON register for a rising event.
  - Set the INTN bit in the CLCxCON register for a falling event.
  - Set the CLCxIE bit of the associated PIE registers.
  - Set the GIE and PEIE bits of the INTCON register.
- Enable the CLCx by setting the EN bit of the CLCxCON register.

## 28.2 CLCx Interrupts

An interrupt will be generated upon a change in the output value of the CLCx when the appropriate interrupt enables are set. A rising edge detector and a falling edge detector are present in each CLCx for this purpose.

The CLCxIF bit of the associated PIR registers will be set when either edge detector is triggered and its associated enable bit is set. The INTP enables rising edge interrupts and the INTN bit enables falling edge interrupts. Both are located in the CLCxCON register.

To fully enable the interrupt, set the following bits:

- EN bit of the CLCxCON register
- CLCxIE bit of the associated PIE registers
- INTP bit of the CLCxCON register (for a rising edge detection)
- INTN bit of the CLCxCON register (for a falling edge detection)
- PEIE and GIE bits of the INTCON register

The CLCxIF bit of the associated PIR registers must be cleared in software as part of the interrupt service. If another edge is detected while this flag is being cleared, the flag will still be set at the end of the sequence.

## 28.3 Output Mirror Copies

Mirror copies of all CLCxCON output bits are contained in the CLCxDATA register. Reading this register reads the outputs of all CLCxs simultaneously. This prevents any reading skew introduced by testing or reading the CLCxOUT bits in the individual CLCxCON registers.

## 28.4 Effects of a Reset

The CLCxCON register is cleared to zero as the result of a Reset. All other selection and gating values remain unchanged.

## 28.5 Operation During Sleep

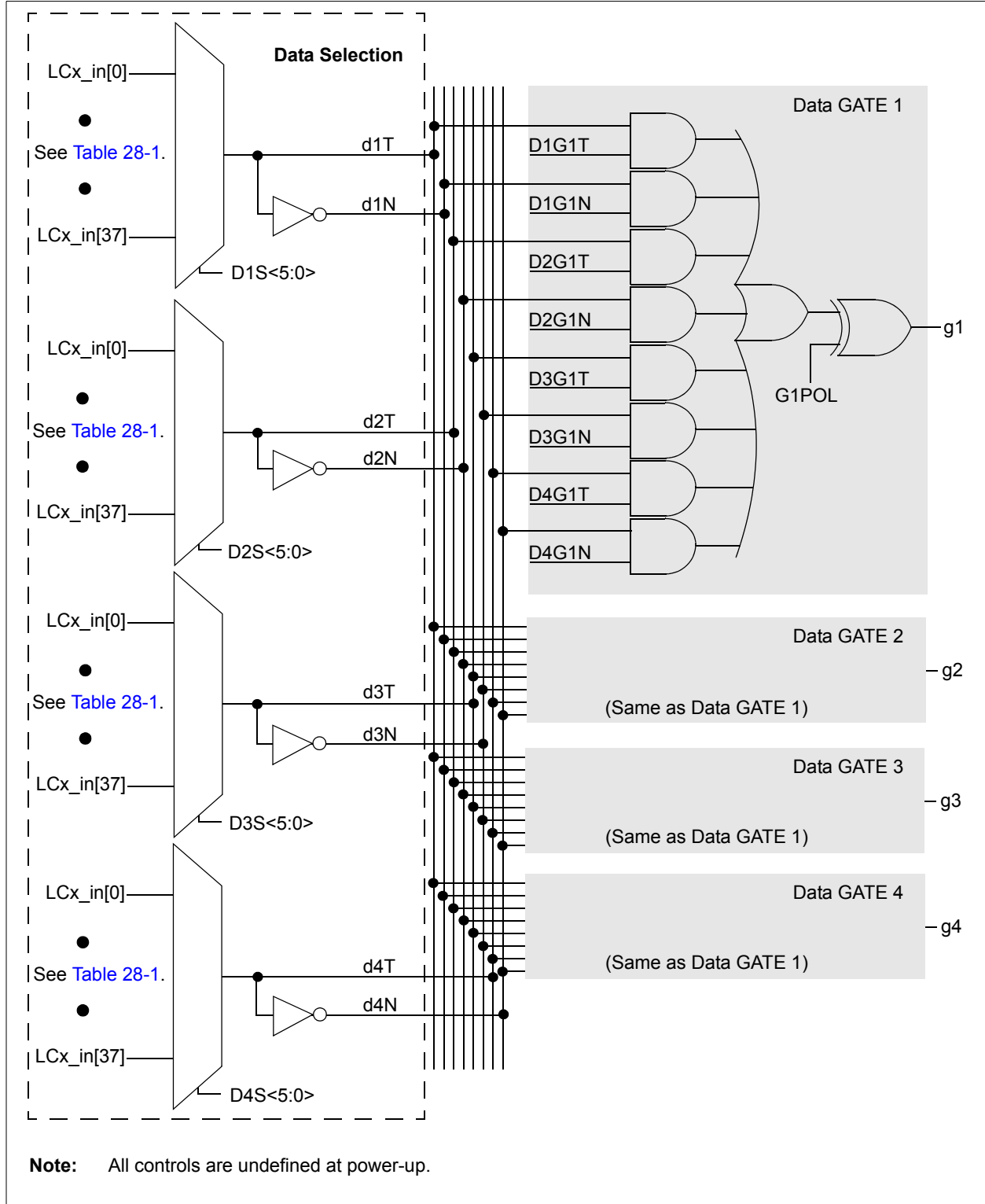
The CLCx module operates independently from the system clock and will continue to run during Sleep, provided that the input sources selected remain active.

The HFINTOSC remains active during Sleep when the CLCx module is enabled and the HFINTOSC is selected as an input source, regardless of the system clock source selected.

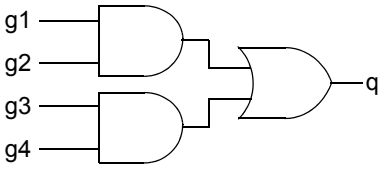
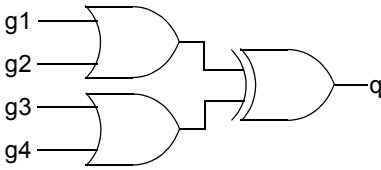
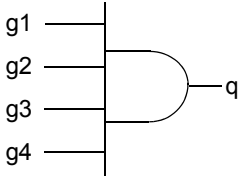
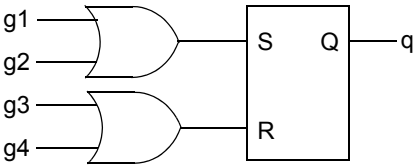
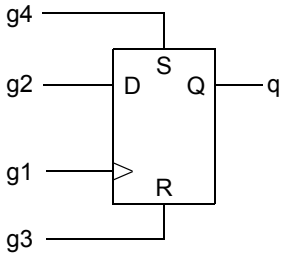
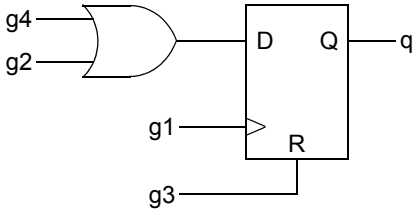
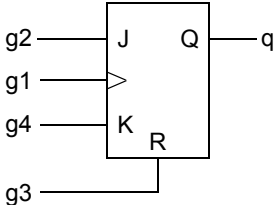
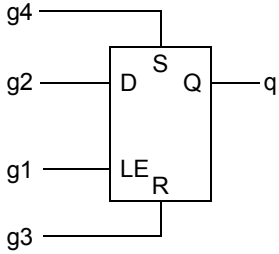
In other words, if the HFINTOSC is simultaneously selected as the system clock and as a CLCx input source when the CLCx is enabled, the CPU will go Idle during Sleep, but the CLCx will continue to operate and the HFINTOSC will remain active.

This will have a direct effect on the Sleep mode current.

**FIGURE 28-2: INPUT DATA SELECTION AND GATING**



**FIGURE 28-3: PROGRAMMABLE LOGIC FUNCTIONS**

<p style="text-align: center;"><b>AND – OR</b></p>  <p style="text-align: center;">MODE&lt;2:0&gt;= 000</p>	<p style="text-align: center;"><b>OR – XOR</b></p>  <p style="text-align: center;">MODE&lt;2:0&gt;= 001</p>
<p style="text-align: center;"><b>4-Input AND</b></p>  <p style="text-align: center;">MODE&lt;2:0&gt;= 010</p>	<p style="text-align: center;"><b>S-R Latch</b></p>  <p style="text-align: center;">MODE&lt;2:0&gt;= 011</p>
<p style="text-align: center;"><b>1-Input D Flip-Flop with S and R</b></p>  <p style="text-align: center;">MODE&lt;2:0&gt;= 100</p>	<p style="text-align: center;"><b>2-Input D Flip-Flop with R</b></p>  <p style="text-align: center;">MODE&lt;2:0&gt;= 101</p>
<p style="text-align: center;"><b>J-K Flip-Flop with R</b></p>  <p style="text-align: center;">MODE&lt;2:0&gt;= 110</p>	<p style="text-align: center;"><b>1-Input Transparent Latch with S and R</b></p>  <p style="text-align: center;">MODE&lt;2:0&gt;= 111</p>

## 28.6 Register Definitions: CLC Control

Long bit name prefixes for the CLC peripherals are shown in [Table 28-3](#). Refer to [Section 1.1 “Register and Bit Naming Conventions”](#) for more information.

**TABLE 28-3: BIT NAME PREFIXES**

Peripheral	Bit Name Prefix
CLC1	LC1
CLC2	LC2

### REGISTER 28-1: CLCxCON: CLCx CONTROL REGISTER

R/W-0/0	U-0	R-0/0	R/W-0/0	R/W-0/0	R/W-0/0	R/W-0/0	R/W-0/0
EN	—	OUT	INTP	INTN	MODE<2:0>		
bit 7							bit 0

**Legend:**

R = Readable bit

W = Writable bit

u = Bit is unchanged

x = Bit is unknown

U = Unimplemented bit, read as '0'

'1' = Bit is set

'0' = Bit is cleared

-n/n = Value at POR and BOR/Value at all other Resets

- bit 7      **EN:** CLCx Enable bit  
           1 = CLCx is enabled and mixing input signals  
           0 = CLCx is disabled and has logic zero output
- bit 6      **Unimplemented:** Read as '0'
- bit 5      **OUT:** CLCx Data Output bit  
           Read-only: logic cell output data, after POL; sampled from lcx\_out wire.
- bit 4      **INTP:** CLCx Positive Edge Going Interrupt Enable bit  
           1 = CLCxIF will be set when a rising edge occurs on lcx\_out  
           0 = CLCxIF will not be set
- bit 3      **INTN:** CLCx Negative Edge Going Interrupt Enable bit  
           1 = CLCxIF will be set when a falling edge occurs on lcx\_out  
           0 = CLCxIF will not be set
- bit 2-0    **MODE<2:0>:** CLCx Functional Mode bits  
           111 = Cell is 1-Input Transparent Latch with S and R  
           110 = Cell is J-K Flip-Flop with R  
           101 = Cell is 2-Input D Flip-Flop with R  
           100 = Cell is 1-Input D Flip-Flop with S and R  
           011 = Cell is S-R Latch  
           010 = Cell is 4-Input AND  
           001 = Cell is OR-XOR  
           000 = Cell is AND-OR

## REGISTER 28-2: CLCxPOL: CLCx SIGNAL POLARITY CONTROL REGISTER

R/W-0/0	U-0	U-0	U-0	R/W-x/u	R/W-x/u	R/W-x/u	R/W-x/u
POL	—	—	—	G4POL	G3POL	G2POL	G1POL
bit 7							bit 0

### Legend:

R = Readable bit

W = Writable bit

u = Bit is unchanged

x = Bit is unknown

U = Unimplemented bit, read as '0'

'1' = Bit is set

'0' = Bit is cleared

-n/n = Value at POR and BOR/Value at all other Resets

- bit 7      **POL:** LCOOUT Polarity Control bit  
1 = The output of the logic cell is inverted  
0 = The output of the logic cell is not inverted
- bit 6-4    **Unimplemented:** Read as '0'
- bit 3      **G4POL:** Gate 4 Output Polarity Control bit  
1 = The output of Gate 4 is inverted when applied to the logic cell  
0 = The output of Gate 4 is not inverted
- bit 2      **G3POL:** Gate 3 Output Polarity Control bit  
1 = The output of Gate 3 is inverted when applied to the logic cell  
0 = The output of Gate 3 is not inverted
- bit 1      **G2POL:** Gate 2 Output Polarity Control bit  
1 = The output of Gate 2 is inverted when applied to the logic cell  
0 = The output of Gate 2 is not inverted
- bit 0      **G1POL:** Gate 1 Output Polarity Control bit  
1 = The output of Gate 1 is inverted when applied to the logic cell  
0 = The output of Gate 1 is not inverted

# PIC16(L)F1764/5/8/9

## REGISTER 28-3: CLCxSEL0: GENERIC CLCx DATA 1 SELECT REGISTER

U-0	U-0	R/W-x/u	R/W-x/u	R/W-x/u	R/W-x/u	R/W-x/u	R/W-x/u
—	—	D1S<5:0>					
bit 7							bit 0

### Legend:

R = Readable bit                      W = Writable bit  
u = Bit is unchanged                  x = Bit is unknown                  U = Unimplemented bit, read as '0'  
'1' = Bit is set                          '0' = Bit is cleared                  -n/n = Value at POR and BOR/Value at all other Resets

bit 7-6            **Unimplemented:** Read as '0'  
bit 5-0            **D1S<5:0>:** CLCx Data1 Input Selection bits  
See [Table 28-1](#).

## REGISTER 28-4: CLCxSEL1: GENERIC CLCx DATA 2 SELECT REGISTER

U-0	U-0	R/W-x/u	R/W-x/u	R/W-x/u	R/W-x/u	R/W-x/u	R/W-x/u
—	—	D2S<5:0>					
bit 7							bit 0

### Legend:

R = Readable bit                      W = Writable bit  
u = Bit is unchanged                  x = Bit is unknown                  U = Unimplemented bit, read as '0'  
'1' = Bit is set                          '0' = Bit is cleared                  -n/n = Value at POR and BOR/Value at all other Resets

bit 7-6            **Unimplemented:** Read as '0'  
bit 5-0            **D2S<5:0>:** CLCx Data 2 Input Selection bits  
See [Table 28-1](#).

## REGISTER 28-5: CLCxSEL2: GENERIC CLCx DATA 3 SELECT REGISTER

U-0	U-0	R/W-x/u	R/W-x/u	R/W-x/u	R/W-x/u	R/W-x/u	R/W-x/u
—	—	D3S<5:0>					
bit 7							bit 0

### Legend:

R = Readable bit                      W = Writable bit  
u = Bit is unchanged                  x = Bit is unknown                  U = Unimplemented bit, read as '0'  
'1' = Bit is set                          '0' = Bit is cleared                  -n/n = Value at POR and BOR/Value at all other Resets

bit 7-6            **Unimplemented:** Read as '0'  
bit 5-0            **D3S<5:0>:** CLCx Data 3 Input Selection bits  
See [Table 28-1](#).

## REGISTER 28-6: CLCxSEL3: GENERIC CLCx DATA 4 SELECT REGISTER

U-0	U-0	R/W-x/u	R/W-x/u	R/W-x/u	R/W-x/u	R/W-x/u	R/W-x/u
—	—	D4S<5:0>					
bit 7							bit 0

### Legend:

R = Readable bit                      W = Writable bit  
u = Bit is unchanged                  x = Bit is unknown                  U = Unimplemented bit, read as '0'  
'1' = Bit is set                          '0' = Bit is cleared                  -n/n = Value at POR and BOR/Value at all other Resets

bit 7-6            **Unimplemented:** Read as '0'  
bit 5-0            **D4S<5:0>:** CLCx Data 4 Input Selection bits  
See [Table 28-1](#).

## REGISTER 28-7: CLCxGLS0: CLCx GATE 1 LOGIC SELECT REGISTER

R/W-x/u	R/W-x/u	R/W-x/u	R/W-x/u	R/W-x/u	R/W-x/u	R/W-x/u	R/W-x/u
G1D4T	G1D4N	G1D3T	G1D3N	G1D2T	G1D2N	G1D1T	G1D1N
bit 7							bit 0

### Legend:

R = Readable bit                      W = Writable bit  
u = Bit is unchanged                  x = Bit is unknown                  U = Unimplemented bit, read as '0'  
'1' = Bit is set                          '0' = Bit is cleared                  -n/n = Value at POR and BOR/Value at all other Resets

bit 7            **G1D4T:** Gate 1 Data 4 True (noninverted) bit  
1 = d4T is gated into g1  
0 = d4T is not gated into g1

bit 6            **G1D4N:** Gate 1 Data 4 Negated (inverted) bit  
1 = d4N is gated into g1  
0 = d4N is not gated into g1

bit 5            **G1D3T:** Gate 1 Data 3 True (noninverted) bit  
1 = d3T is gated into g1  
0 = d3T is not gated into g1

bit 4            **G1D3N:** Gate 1 Data 3 Negated (inverted) bit  
1 = d3N is gated into g1  
0 = d3N is not gated into g1

bit 3            **G1D2T:** Gate 1 Data 2 True (noninverted) bit  
1 = d2T is gated into g1  
0 = d2T is not gated into g1

bit 2            **G1D2N:** Gate 1 Data 2 Negated (inverted) bit  
1 = d2N is gated into g1  
0 = d2N is not gated into g1

bit 1            **G1D1T:** Gate 1 Data 1 True (noninverted) bit  
1 = d1T is gated into g1  
0 = d1T is not gated into g1

bit 0            **G1D1N:** Gate 1 Data 1 Negated (inverted) bit  
1 = d1N is gated into g1  
0 = d1N is not gated into g1

## REGISTER 28-8: CLCxGLS1: CLCx GATE 2 LOGIC SELECT REGISTER

R/W-x/u	R/W-x/u	R/W-x/u	R/W-x/u	R/W-x/u	R/W-x/u	R/W-x/u	R/W-x/u
G2D4T	G2D4N	G2D3T	G2D3N	G2D2T	G2D2N	G2D1T	G2D1N
bit 7							bit 0

### Legend:

R = Readable bit

W = Writable bit

u = Bit is unchanged

x = Bit is unknown

U = Unimplemented bit, read as '0'

'1' = Bit is set

'0' = Bit is cleared

-n/n = Value at POR and BOR/Value at all other Resets

- bit 7      **G2D4T:** Gate 2 Data 4 True (noninverted) bit  
1 = d4T is gated into g2  
0 = d4T is not gated into g2
- bit 6      **G2D4N:** Gate 2 Data 4 Negated (inverted) bit  
1 = d4N is gated into g2  
0 = d4N is not gated into g2
- bit 5      **G2D3T:** Gate 2 Data 3 True (noninverted) bit  
1 = d3T is gated into g2  
0 = d3T is not gated into g2
- bit 4      **G2D3N:** Gate 2 Data 3 Negated (inverted) bit  
1 = d3N is gated into g2  
0 = d3N is not gated into g2
- bit 3      **G2D2T:** Gate 2 Data 2 True (noninverted) bit  
1 = d2T is gated into g2  
0 = d2T is not gated into g2
- bit 2      **G2D2N:** Gate 2 Data 2 Negated (inverted) bit  
1 = d2N is gated into g2  
0 = d2N is not gated into g2
- bit 1      **G2D1T:** Gate 2 Data 1 True (noninverted) bit  
1 = d1T is gated into g2  
0 = d1T is not gated into g2
- bit 0      **G2D1N:** Gate 2 Data 1 Negated (inverted) bit  
1 = d1N is gated into g2  
0 = d1N is not gated into g2



## REGISTER 28-9: CLCxGLS2: CLCx GATE 3 LOGIC SELECT REGISTER

R/W-x/u	R/W-x/u	R/W-x/u	R/W-x/u	R/W-x/u	R/W-x/u	R/W-x/u	R/W-x/u
G3D4T	G3D4N	G3D3T	G3D3N	G3D2T	G3D2N	G3D1T	G3D1N
bit 7							bit 0

### Legend:

R = Readable bit	W = Writable bit	
u = Bit is unchanged	x = Bit is unknown	U = Unimplemented bit, read as '0'
'1' = Bit is set	'0' = Bit is cleared	-n/n = Value at POR and BOR/Value at all other Resets

bit 7	<b>G3D4T:</b> Gate 3 Data 4 True (noninverted) bit 1 = d4T is gated into g3 0 = d4T is not gated into g3
bit 6	<b>G3D4N:</b> Gate 3 Data 4 Negated (inverted) bit 1 = d4N is gated into g3 0 = d4N is not gated into g3
bit 5	<b>G3D3T:</b> Gate 3 Data 3 True (noninverted) bit 1 = d3T is gated into g3 0 = d3T is not gated into g3
bit 4	<b>G3D3N:</b> Gate 3 Data 3 Negated (inverted) bit 1 = d3N is gated into g3 0 = d3N is not gated into g3
bit 3	<b>G3D2T:</b> Gate 3 Data 2 True (noninverted) bit 1 = d2T is gated into g3 0 = d2T is not gated into g3
bit 2	<b>G3D2N:</b> Gate 3 Data 2 Negated (inverted) bit 1 = d2N is gated into g3 0 = d2N is not gated into g3
bit 1	<b>G3D1T:</b> Gate 3 Data 1 True (noninverted) bit 1 = d1T is gated into g3 0 = d1T is not gated into g3
bit 0	<b>G3D1N:</b> Gate 3 Data 1 Negated (inverted) bit 1 = d1N is gated into g3 0 = d1N is not gated into g3

# PIC16(L)F1764/5/8/9

## REGISTER 28-10: CLCxGLS3: CLCx GATE 4 LOGIC SELECT REGISTER

R/W-x/u	R/W-x/u	R/W-x/u	R/W-x/u	R/W-x/u	R/W-x/u	R/W-x/u	R/W-x/u
G4D4T	G4D4N	G4D3T	G4D3N	G4D2T	G4D2N	G4D1T	G4D1N
bit 7							bit 0

### Legend:

R = Readable bit

W = Writable bit

u = Bit is unchanged

x = Bit is unknown

U = Unimplemented bit, read as '0'

'1' = Bit is set

'0' = Bit is cleared

-n/n = Value at POR and BOR/Value at all other Resets

- bit 7      **G4D4T:** Gate 4 Data 4 True (noninverted) bit  
1 = d4T is gated into g4  
0 = d4T is not gated into g4
- bit 6      **G4D4N:** Gate 4 Data 4 Negated (inverted) bit  
1 = d4N is gated into g4  
0 = d4N is not gated into g4
- bit 5      **G4D3T:** Gate 4 Data 3 True (noninverted) bit  
1 = d3T is gated into g4  
0 = d3T is not gated into g4
- bit 4      **G4D3N:** Gate 4 Data 3 Negated (inverted) bit  
1 = d3N is gated into g4  
0 = d3N is not gated into g4
- bit 3      **G4D2T:** Gate 4 Data 2 True (noninverted) bit  
1 = d2T is gated into g4  
0 = d2T is not gated into g4
- bit 2      **G4D2N:** Gate 4 Data 2 Negated (inverted) bit  
1 = d2N is gated into g4  
0 = d2N is not gated into g4
- bit 1      **G4D1T:** Gate 4 Data 1 True (noninverted) bit  
1 = d1T is gated into g4  
0 = d1T is not gated into g4
- bit 0      **G4D1N:** Gate 4 Data 1 Negated (inverted) bit  
1 = d1N is gated into g4  
0 = d1N is not gated into g4

# PIC16(L)F1764/5/8/9

**REGISTER 28-11: CLCxDATA: CLCx DATA OUTPUT**

U-0	U-0	U-0	U-0	U-0	R-0	R-0	R-0
—	—	—	—	—	MLC3OUT	MLC2OUT	MLC1OUT
bit 7					bit 0		

**Legend:**

R = Readable bit                      W = Writable bit  
u = Bit is unchanged                  x = Bit is unknown                  U = Unimplemented bit, read as '0'  
'1' = Bit is set                            '0' = Bit is cleared                  -n/n = Value at POR and BOR/Value at all other Resets

bit 7-3            **Unimplemented:** Read as '0'  
bit 2              **MLC3OUT:** Mirror copy of LC3OUT bit  
bit 1              **MLC2OUT:** Mirror copy of LC2OUT bit  
bit 0              **MLC1OUT:** Mirror copy of LC1OUT bit

**TABLE 28-4: SUMMARY OF REGISTERS ASSOCIATED WITH CLCx**

Name	Bit7	Bit6	Bit5	Bit4	Bit3	Bit2	Bit1	Bit0	Register on Page
ANSELA	—	—	—	ANSA4	—	ANSA<2:0>			139
ANSELB <sup>(1)</sup>	ANSB<7:4>				—	—	—	—	145
ANSELC	ANSC<7:6> <sup>(1)</sup>			—	—	ANSC<3:0>			150
CLCxCON	EN	—	OUT	INTP	INTN	MODE<2:0>			340
CLCDATA	—	—	—	—	—	MLC3OUT	MLC2OUT	MLC1OUT	347
CLCxGLS0	G1D4T	G1D4N	G1D3T	G1D3N	G1D2T	G1D2N	G1D1T	G1D1N	343
CLCxGLS1	G2D4T	G2D4N	G2D3T	G2D3N	G2D2T	G2D2N	G2D1T	G2D1N	344
CLCxGLS2	G3D4T	G3D4N	G3D3T	G3D3N	G3D2T	G3D2N	G3D1T	G3D1N	345
CLCxGLS3	G4D4T	G4D4N	G4D3T	G4D3N	G4D2T	G4D2N	G4D1T	G4D1N	346
CLCxPOL	POL	—	—	—	G4POL	G3POL	G2POL	G1POL	341
CLCxSEL0	—	—	D1S<5:0>						342
CLCxSEL1	—	—	D2S<5:0>						342
CLCxSEL2	—	—	D3S<5:0>						342
CLCxSEL3	—	—	D4S<5:0>						343
CLCxPPS	—	—	—	CLCxPPS<4:0>					156, 158
INTCON	GIE	PEIE	TMR0IE	INTE	IOCFIE	TMR0IF	INTF	IOCFIF	101
PIE3	PWM6IE <sup>(1)</sup>	PWM5IE	COG1IE	ZCDIE	COG2IE <sup>(1)</sup>	CLC3IE	CLC2IE	CLC1IE	104
PIR3	PWM6IF <sup>(1)</sup>	PWM5IF	COG1IF	ZCDIF	COG2IF <sup>(1)</sup>	CLC3IF	CLC2IF	CLC1IF	108
RxyPPS	—	—	—	RxyPPS<4:0>					156
TRISA	—	—	TRISA<5:4>		— <sup>(3)</sup>	TRISA<2:0>			138
TRISB <sup>(1)</sup>	TRISB<7:4>				—	—	—	—	144
TRISC	TRISC<7:6> <sup>(1)</sup>		TRISC<5:0>						149

**Legend:** — = unimplemented location, read as '0'. Shaded cells are not used for CLCx module.

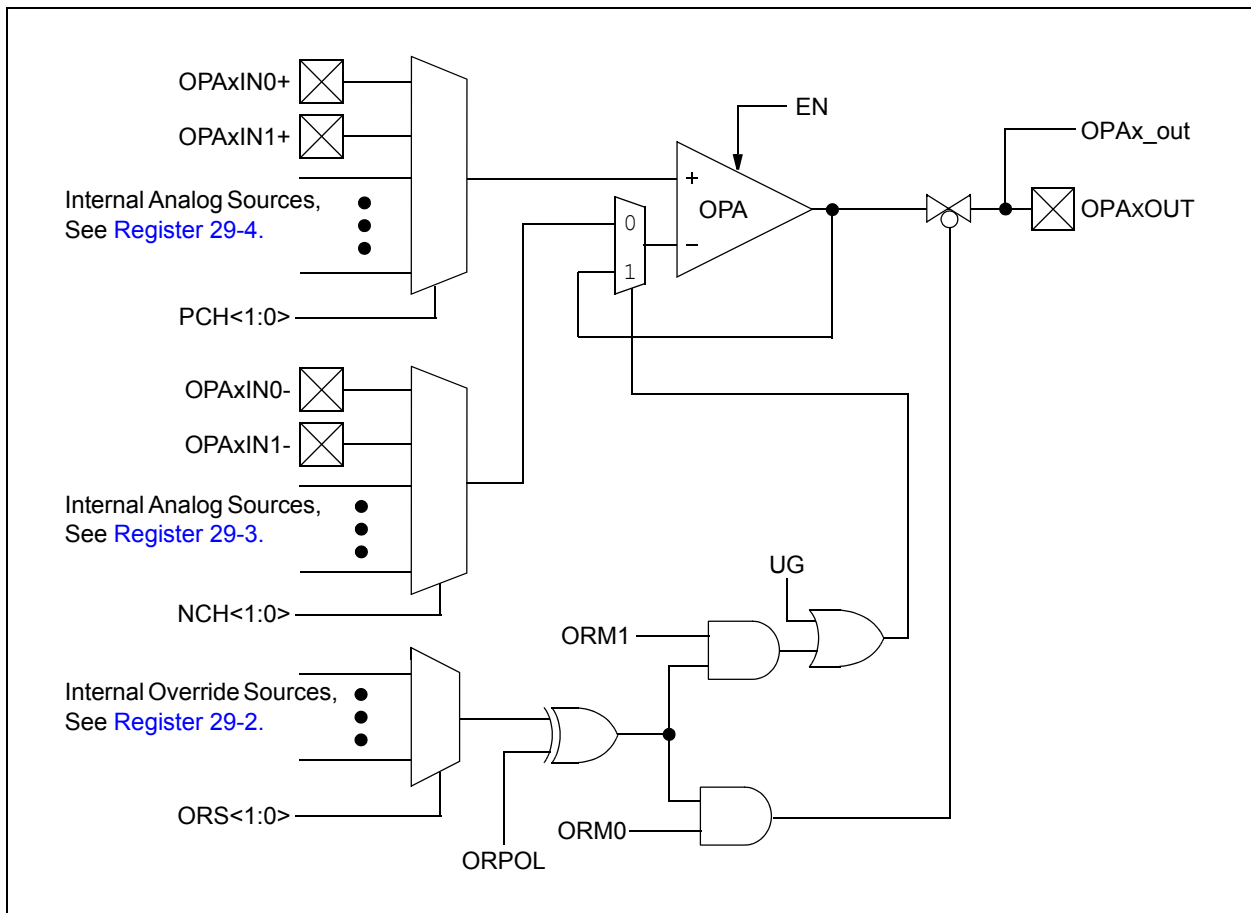
**Note 1:** PIC16(L)F1768/9 only.  
**2:** Unimplemented, read as '1'.

## 29.0 OPERATIONAL AMPLIFIER (OPA) MODULES

The Operational Amplifier (OPA) is a standard three-terminal device requiring external feedback to operate. The OPA module has the following features:

- External connections to I/O ports
- Low leakage inputs
- Factory calibrated input offset voltage
- Unity gain control
- Programmable positive and negative source selections
- Override controls:
  - Forced tri-state output
  - Forced unity gain

**FIGURE 29-1: OPAx MODULE BLOCK DIAGRAM**



## 29.1 OPA Module Performance

Common AC and DC performance specifications for the OPA module:

- Common-Mode Voltage Range
- Leakage Current
- Input Offset Voltage
- Open-Loop Gain
- Gain Bandwidth Product

**Common-mode voltage range** is the specified voltage range for the OPA+ and OPA- inputs, for which the OPA module will perform to within its specifications. The OPA module is designed to operate with input voltages between V<sub>SS</sub> and V<sub>DD</sub>. Behavior for Common-mode voltages greater than V<sub>DD</sub>, or below V<sub>SS</sub>, are not guaranteed.

**Leakage current** is a measure of the small source or sink currents on the OPA+ and OPA- inputs. To minimize the effect of leakage currents, the effective impedances connected to the OPA+ and OPA- inputs should be kept as small as possible and equal.

**Input offset voltage** is a measure of the voltage difference between the OPA+ and OPA- inputs in a closed loop circuit with the OPA in its linear region. The offset voltage will appear as a DC offset in the output equal to the input offset voltage, multiplied by the gain of the circuit. The input offset voltage is also affected by the Common-mode voltage. The OPA is factory calibrated to minimize the input offset voltage of the module.

**Open-loop gain** is the ratio of the output voltage to the differential input voltage, (OPA+) – (OPA-). The gain is greatest at DC and falls off with frequency.

**Gain Bandwidth Product** or GBWP is the frequency at which the open-loop gain falls off to 0 dB.

## 29.2 OPA Module Control

The OPA module is enabled by setting the OPAXEN bit of the OPAXCON register ([Register 29-1](#)). When enabled, the OPA forces the output driver of OPAXOUT pin into tri-state to prevent contention between the driver and the OPA output.

**Note:** When the OPA module is enabled, the OPAXOUT pin is driven by the op amp output, not by the PORT digital driver. Refer to [Table 36-17: Operational Amplifier \(OPA\)](#) for the op amp output drive capability.

### 29.2.1 UNITY GAIN MODE

The OPAXUG bit of the OPAXCON register ([Register 29-1](#)) selects the Unity Gain mode. When unity gain is selected, the OPA output is connected to the inverting input and the OPAXIN pin is relinquished, releasing the pin for general purpose input and output.

### 29.2.2 PROGRAMMABLE SOURCE SELECTIONS

The inverting and noninverting sources are selected with the OPAXNCHS ([Register 29-3](#)) and OPAXPCHS ([Register 29-4](#)) registers, respectively. Sources include:

- Internal DACs
- Device pins
- Internal slope compensation ramp generator
- Other op amps in the device

## 29.3 Override Control

### 29.3.1 OVERRIDE MODE

The op amp operation can be overridden in two ways:

- Forced tri-state output
- Force unity gain

The Override mode is selected with the ORM<1:0> bits of the OPXCON register ([Register 29-1](#)). The override is in effect when the mode is selected and the override source is true.

### 29.3.2 OVERRIDE SOURCES

The override source is selected with the OPAXORS register ([Register 29-2](#)). Sources are from internal peripherals including:

- CCP outputs
- PWM outputs
- Comparator outputs
- Zero-Cross Detect (ZCD) output
- Configurable Logic Cell outputs
- COG outputs

### 29.3.3 OVERRIDE SOURCE POLARITY

The override source polarity can be inverted so that the override will occur on either the high or low level of the selected source. Override polarity is controlled by the ORPOL bit of the OPAXCON register ([Register 29-1](#)).

## 29.4 Effects of Reset

A device Reset forces all registers to their Reset state. This disables the OPA module.

## 29.5 Effects of Sleep

The operational amplifier continues to operate when the device is put in Sleep mode.

## 29.6 Register Definitions: Op Amp Control

Long bit name prefixes for the op amp peripherals are shown in [Table 29-1](#). Refer to [Section 1.1 “Register and Bit Naming Conventions”](#) for more information.

**TABLE 29-1: BIT NAME PREFIXES**

Peripheral	Bit Name Prefix
OPA1	OPA1
OPA2 <sup>(1)</sup>	OPA2

**Note 1:** PIC16(L)F1768/9 devices only.

### REGISTER 29-1: OPAXCON: OPERATIONAL AMPLIFIER x (OPAx) CONTROL REGISTER

R/W-0/0	U-0	U-0	R/W-0/0	U-0	R/W-0/0	R/W-0/0	R/W-0/0
EN	—	—	UG	—	ORPOL	ORM<1:0>	
bit 7							bit 0

**Legend:**

R = Readable bit	W = Writable bit	
u = Bit is unchanged	x = Bit is unknown	U = Unimplemented bit, read as '0'
'1' = Bit is set	'0' = Bit is cleared	-n/n = Value at POR and BOR/Value at all other Resets

- bit 7      **EN:** Op Amp Enable bit  
           1 = Op amp is enabled  
           0 = Op amp is disabled and consumes no active power
- bit 6-5    **Unimplemented:** Read as '0'
- bit 4      **UG:** Op Amp Unity Gain Select bit  
           1 = OPA output is connected to inverting input; OPAXIN- pin is available for general purpose I/O  
           0 = Inverting input is connected to the OPAXIN- pin
- bit 3      **Unimplemented:** Read as '0'
- bit 2      **ORPOL:** Op Amp Override Source Polarity bit  
           1 = Override source polarity is inverted; override occurs when source is high  
           0 = Override source polarity is not inverted; override occurs when source is low
- bit 1-0    **ORM<1:0>:** Op Amp Override Mode Selection bits  
           11 = Reserved; do not use  
           10 = Op amp is forced to unity gain when override source is true  
           01 = Op amp output is tri-stated when override source is true  
           00 = Output override function is disabled

# PIC16(L)F1764/5/8/9

## REGISTER 29-2: OPAxORS: OP AMP x OVERRIDE SOURCE SELECTION REGISTER

U-0	U-0	U-0	R/W-0/0	R/W-0/x	R/W-0/x	R/W-0/0	R/W-0/x
—	—	—	ORS<4:0>				
bit 7							bit 0

### Legend:

R = Readable bit

W = Writable bit

u = Bit is unchanged

x = Bit is unknown

U = Unimplemented bit, read as '0'

'1' = Bit is set

'0' = Bit is cleared

-n/n = Value at POR and BOR/Value at all other Resets

bit 7-5

**Unimplemented:** Read as '0'

bit 4-0

**ORS<4:0>:** Op Amp Output Override Source Selection bits

11111 = Reserved; do not use

•  
•  
•

10110 = Reserved; do not use

10101 = Override source is COG2D<sup>(1)</sup>

10100 = Override source is COG2C<sup>(1)</sup>

10011 = Override source is COG2B<sup>(1)</sup>

10010 = Override source is COG2A<sup>(1)</sup>

10001 = Override source is COG1C

10000 = Override source is COG1C

01111 = Override source is COG1B

01110 = Override source is COG1A

01101 = Override source is LC3\_out

01100 = Override source is LC2\_out

01011 = Override source is LC1\_out

01010 = Override source is ZCD1\_output

01001 = Override source is sync\_C4OUT<sup>(1)</sup>

01000 = Override source is sync\_C3OUT<sup>(1)</sup>

00111 = Override source is sync\_C2OUT

00110 = Override source is sync\_C1OUT

00101 = Override source is PWM6\_out<sup>(1)</sup>

00100 = Override source is PWM5\_out

00011 = Override source is PWM4\_out<sup>(1)</sup>

00010 = Override source is PWM3\_out

00001 = Override source is CCP2\_out<sup>(1)</sup>

00000 = Override source is CCP1\_out

**Note 1:** PIC16(L)F1768/9 only

# PIC16(L)F1764/5/8/9

## REGISTER 29-3: OPAXNCHS: OP AMP x NEGATIVE CHANNEL SOURCE SELECT REGISTER

U-0	U-0	U-0	U-0	R/W-0/0	R/W-0/0	R/W-0/0	R/W-0/0
—	—	—	—	NCH<3:0>			
bit 7				bit 0			

### Legend:

R = Readable bit

W = Writable bit

u = Bit is unchanged

x = Bit is unknown

U = Unimplemented bit, read as '0'

'1' = Bit is set

'0' = Bit is cleared

-n/n = Value at POR and BOR/Value at all other Resets

bit 7-4

**Unimplemented:** Read as '0'

bit 3-0

**NCH<3:0>:** Op Amp Inverting Input Channel Selection bits

1111 = Reserved; do not use

•  
•  
•

1010 = Reserved; do not use

1001 = Programmable Ramp Generator PRG2\_out<sup>(1)</sup>

1000 = Programmable Ramp Generator PRG1\_out

0111 = Reserved. Do not use.

0110 = FVR\_Buffer2

0101 = DAC4\_out<sup>(1)</sup>

0100 = DAC3\_out

0011 = DAC2\_out<sup>(1)</sup>

0010 = DAC1\_out

0001 = OPAXIN1- pin<sup>(1)</sup>

0000 = OPAXIN0- pin

**Note 1:** PIC16(L)F1768/9 only



# PIC16(L)F1764/5/8/9

**REGISTER 29-4: OPAXPCHS: OP AMP x POSITIVE CHANNEL SOURCE SELECT REGISTER**

U-0	U-0	U-0	U-0	R/W-0/0	R/W-0/0	R/W-0/0	R/W-0/0
—	—	—	—	PCH<3:0>			
bit 7							bit 0

**Legend:**

R = Readable bit                      W = Writable bit  
u = Bit is unchanged                  x = Bit is unknown                  U = Unimplemented bit, read as '0'  
'1' = Bit is set                          '0' = Bit is cleared                  -n/n = Value at POR and BOR/Value at all other Resets

bit 7-4                      **Unimplemented:** Read as '0'  
bit 3-0                      **PCH<3:0>:** Op Amp Noninverting Input Channel Selection bits  
1111 = Reserved; do not use  
•  
•  
•  
1010 = Reserved; do not use  
1001 = Programmable Ramp Generator PRG2\_out<sup>(1)</sup>  
1000 = Programmable Ramp Generator PRG1\_out  
0111 = Reserved. Do not use.  
0110 = FVR\_Buffer2  
0101 = DAC4\_out<sup>(1)</sup>  
0100 = DAC3\_out  
0011 = DAC2\_out<sup>(1)</sup>  
0010 = DAC1\_out  
0001 = OPAXIN1+ pin<sup>(1)</sup>  
0000 = OPAXIN0+ pin

**Note 1:** PIC16(L)F1768/9 only

**TABLE 29-2: SUMMARY OF REGISTERS ASSOCIATED WITH OP AMPS**

Name	Bit 7	Bit 6	Bit 5	Bit 4	Bit 3	Bit 2	Bit 1	Bit 0	Register on Page
ANSELB <sup>(2)</sup>	ANSB<7:6>		ANSB<5:4>		—	—	—	—	145
ANSELC <sup>(2)</sup>	ANSC<7:6> <sup>(2)</sup>		—	—	ANSC<3:2>		ANSC<1:0>		150
DACxCON0	EN	FM	OE1	—	PSS<1:0>		NSS<1:0>		190
DACxREF	---	---	---	REF<4:0>					191
DACxREFL <sup>(2)</sup>	REF<7:0>								196
DACxREFH <sup>(2)</sup>	REF<15:8>								196
FVRCON	FVREN	FVRRDY	TSEN	TSRNG	CDAFVR<1:0>		ADFVR<1:0>		171
OPAXCON	EN	—	—	UG	—	ORPOL	ORM<1:0>		350
OPAXNCHS	—	—	—	—	NCH<3:0>				352
OPAXPCHS	—	—	—	—	PCH<3:0>				353
OPAXORS	—	—	—	ORS<4:0>					351
TRISB <sup>(2)</sup>	TRISB<7:6>		TRISB<5:4>		—	—	—	—	144
TRISC <sup>(2)</sup>	TRISC<7:6> <sup>(2)</sup>		TRISC<5:4>		TRISC<3:2>		TRISC<1:0>		149

**Legend:** — = unimplemented location, read as '0'. Shaded cells are not used by op amps.

**Note 1:** Unimplemented, read as '1'.

**2:** PIC16(L)F1768/9 only

## 30.0 PROGRAMMABLE RAMP GENERATOR (PRG) MODULE

The Programmable Ramp Generator (PRG) module is designed to provide rising and falling linear ramps. Typical applications include slope compensation for fixed frequency, continuous current and Current mode switched power supplies. Slope compensation is a necessary feature of these power supplies because it prevents frequency instabilities at duty cycles greater than 50%.

The PRG has the following features:

- Linear positive and negative voltage ramp outputs
- Programmable current source/sink
- Internal and external reference voltage selection
- Internal and external timing source selection

A simplified block diagram of the PRG is shown in [Figure 30-1](#).

### 30.1 Fundamental Operation

The PRG can be operated in three voltage ramp generator modes:

- Falling Voltage (slope compensation)
- Rising Voltage
- Alternating Rising and Falling Voltage

In the Rising or Falling mode, an internal capacitor is discharged when the `set_falling` timing input is true and charged by an internally generated constant current when the `set_rising` timing input is true. The resulting linear ramp starts at the selected voltage input level and resets back to that level when the ramp is terminated by the `set_falling` timing input. The `set_falling` input dominates when both timing inputs are true.

To control the operation with a single-ended source, select the same source for both the `set_rising` and `set_falling` inputs and invert the polarity of one of them with the corresponding polarity control bit.

In the Alternating mode, the capacitor is not discharged but alternates between being charged in one direction then the other.

Input selections are identical for all modes. The input voltage is supplied by any of the following:

- The PRGxIN0 or PRGxIN1 pins
- The buffered output of the internal Fixed Voltage Reference (FVR),
- Any of the internal DACs.

The timing sources are selected from the following:

- The synchronized output of any comparator
- Any PWM output
- Any I/O pin

The ramp output is available as an input to any of the comparators or op amps.

**Note:** When the ramp changes direction, a minor nonlinearity will be present in the ramp waveform. This is due to the settling time of the current source/sink in the PRG charge circuit. The nonlinearity is typically between 200-400mV in amplitude and will be more pronounced for faster ramp rates.

#### 30.1.1 SLOPE COMPENSATION

Slope compensation works by quickly discharging an internal capacitor at the beginning of each PWM period. One side of the internal capacitor is connected to the voltage input source and the other side is connected to the internal current sink. The internal current sink charges this capacitor at a programmable rate. As the capacitor charges, the capacitor voltage is subtracted from the voltage source, producing a linear voltage decay at the required rate (see [Figure 30-2](#)). The ramp terminates and the capacitor is discharged when the `set_falling` timing input goes true. The next ramp starts when the `set_rising` timing input goes true.

Enabling the optional one-shot by setting the OS bit of the PRGxCON0 register ensures that the capacitor is fully discharged by overriding the `set_rising` timing input and holding the shorting switch closed for at least the one-shot period, typically 50 ns. Edge-sensitive timing inputs that occur during the one-shot period will be ignored. Level-sensitive timing inputs that occur during, and extend beyond, the one-shot period will be suspended until the end of the one-shot time.

#### 30.1.2 RAMP GENERATION

Ramp generation is similar to slope compensation except that the slope is either both rising and falling or just rising.

##### 30.1.2.1 Alternating Rising/Falling Ramps

The alternating rising/falling ramp generation function works by employing the built-in current source and sink, and relying on the synchronous control of the internal analog switches and timing sources to ramp the module's output voltage up, and then subsequently, down.

Once initialized, the output voltage is ramped up linearly by the current source at a programmable rate until the `set_falling` timing source goes true, at which point the current source is disengaged. At the same time, the current sink is engaged to linearly ramp down the output voltage, also at a programmable rate, until the `set_rising` timing input goes true thereby reversing the ramp slope. The process then repeats to create a saw tooth like waveform, as shown in [Figure 30-3](#) and [Figure 30-4](#).

The `set_rising` and `set_falling` timing inputs can be either edge or level-sensitive, which is selected with the respective REDG and FEDG bits of the PRGxCON0 register. Edge-sensitive operation is recommended for

periodic signals, such as clocks, and level-sensitive operation is recommended for analog limit triggers, such as comparator outputs.

When the one-shot is enabled (OS bit is set), then both the falling and rising ramps will persist for a minimum of the one-shot period. Edge-sensitive timing inputs that occur during the one-shot period will be ignored. Level-sensitive timing inputs that occur during, and extend beyond, the one-shot period will be suspended until the end of the one-shot time.

### 30.1.2.2 Rising Ramp

The Rising Ramp mode is identical to the Slope Compensation mode, except that the ramps have a rising slope instead of a falling slope. One side of the internal capacitor is connected to the voltage input source and the other side is connected to the internal current source. The internal current source charges this capacitor at a programmable rate. As the capacitor charges, the capacitor voltage is added to the voltage source, producing a linear voltage rise at the required rate (see [Figure 30-5](#)). The ramp terminates and the capacitor is discharged when the `set_falling` timing input goes true. The next ramp starts when the `set_rising` timing input goes true.

Enabling the optional one-shot by setting the OS bit of the `PRGxCON0` register ensures that the capacitor is fully discharged by overriding the `set_rising` timing input and holding the shorting switch closed for at least the one-shot period, typically 50 ns. Edge-sensitive timing inputs that occur during the one-shot period will be ignored. Level-sensitive timing inputs that occur during, and extend beyond, the one-shot period will be suspended until the end of the one-shot time.

## 30.2 Enable, Ready, Go

The EN bit of the `PRGxCON0` register enables the analog circuitry including the current sources. This permits preparing the PRG module for use and allowing it to become stable before putting it into operation. When the EN bit is set, then the timing inputs are enabled so that initial ramp action can be determined before the GO bit is set. The capacitor shorting switch is closed when the EN bit is set and remains closed while the GO bit is zero.

The RDY bit of the `PRGxCON1` register indicates that the analog circuits and current sources are stable.

The GO bit of the `PRGxCON0` register enables the switch control circuits, thereby putting the PRG into operation. The GO transition, from cleared to set, triggers the one-shot, thereby extending the capacitor shorting switch closure for the one-shot period.

To ensure predictable operation, set the EN bit first, then wait for the RDY bit to go high before setting the GO bit.

## 30.3 Independent Set\_rising and Set\_falling Timing Inputs

The timing inputs determine when the ramp starts and stops. In the Alternating Rising/Falling mode, the ramp rises when the `set_rising` input goes true and falls when the `set_falling` input goes true. In the Slope Compensation and Rising Ramp modes, the capacitor is discharged when the `set_falling` timing input goes true and the ramp starts when the `set_rising` timing input goes true. The `set_falling` input dominates the `set_rising` input.

## 30.4 Level and Edge Timing Sensitivity

The `set_rising` and `set_falling` timing inputs can be independently configured as either level or edge-sensitive.

Level-sensitive operation is useful when it is necessary to detect a timing input true state after an overriding condition ceases. For example, level sensitivity is useful for capacitor generated timing inputs that may be suppressed by the overriding action of the one-shot. With level sensitivity, a capacitor output that changes during the one-shot period will be detected at the end of the one-shot time. With edge sensitivity, the change would be ignored.

Edge-sensitive operation is useful for periodic timing inputs, such as those generated by PWMs and clocks. The duty cycle of a level-sensitive periodic signal may interfere with the other timing input. Consider an Alternating Ramp mode with a level-sensitive 50% PWM as the `set_rising` timing source and a level-sensitive comparator as the `set_falling` timing source. If the comparator output reverses the ramp while the PWM signal is still high, then the ramp will improperly reverse again when the comparator signal goes low. That same scenario with the `set_rising` timing input set for edge sensitivity would properly change the ramp output to rising only on the rising edge of the PWM signal.

`set_rising` and `set_falling` timing input edge sensitivity is selected with the respective REDG and FEDG bits of the `PRGxCON1` register.

## 30.5 One-Shot Minimum Timing

The one-shot timer ensures a minimum capacitor discharge time in the Slope Compensation and Rising Ramp modes, and a minimum rising or falling ramp duration in the Alternating Ramp mode. Setting the OS bit of the `PRGxCON0` register enables the one-shot timer.

## 30.6 DAC Voltage Sources

When using any of the DACs as the voltage source, expect a voltage offset equal to the current setting times the DAC equivalent resistance. This will be a constant offset in the Slope Compensation and Ramp modes, and a positive/negative step offset in the Alternating mode. To avoid this limitation, feed the DAC output to the PRG input through one of the op amps set for unity gain.

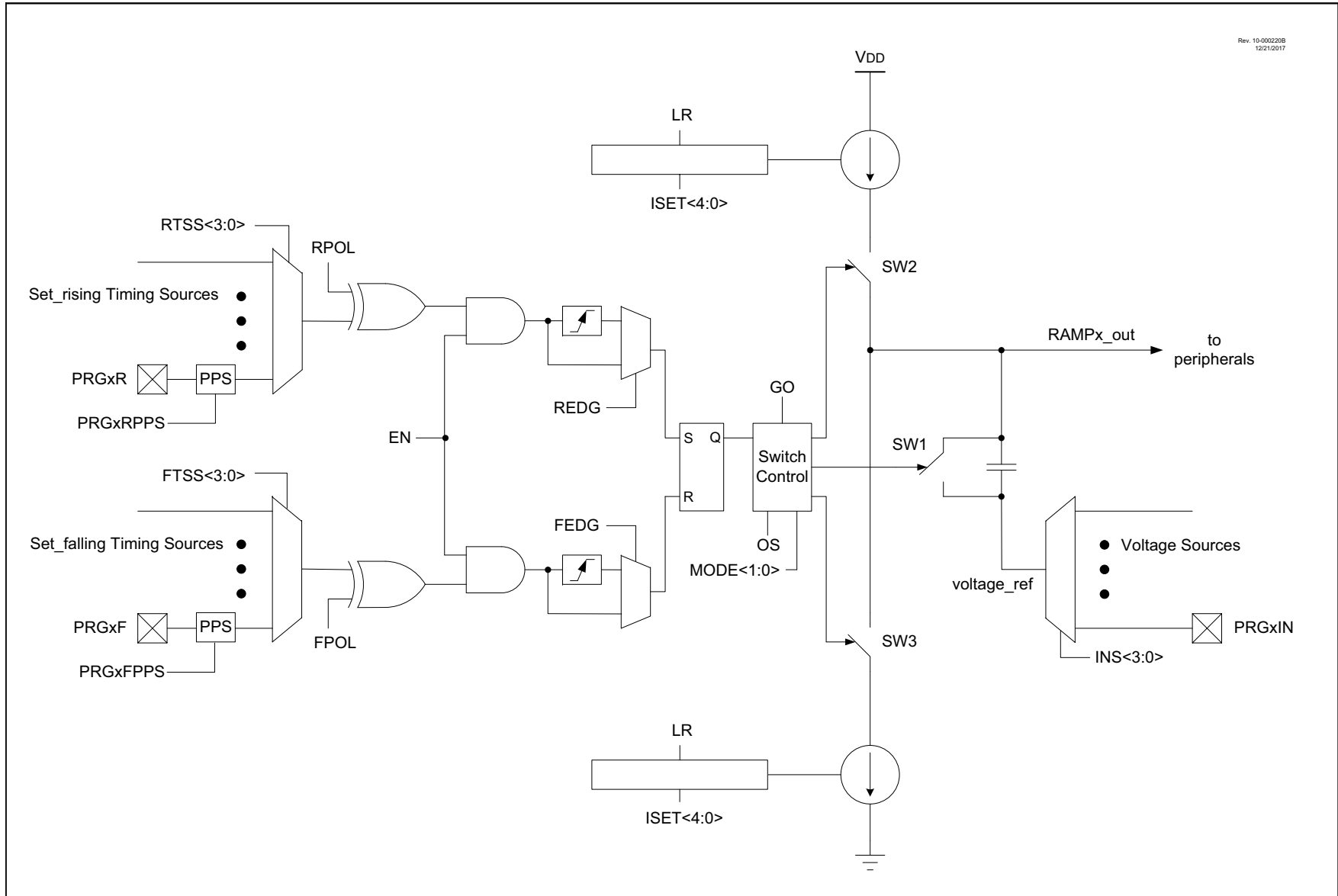
## 30.7 Operation During Sleep

The PRG module is unaffected by Sleep.

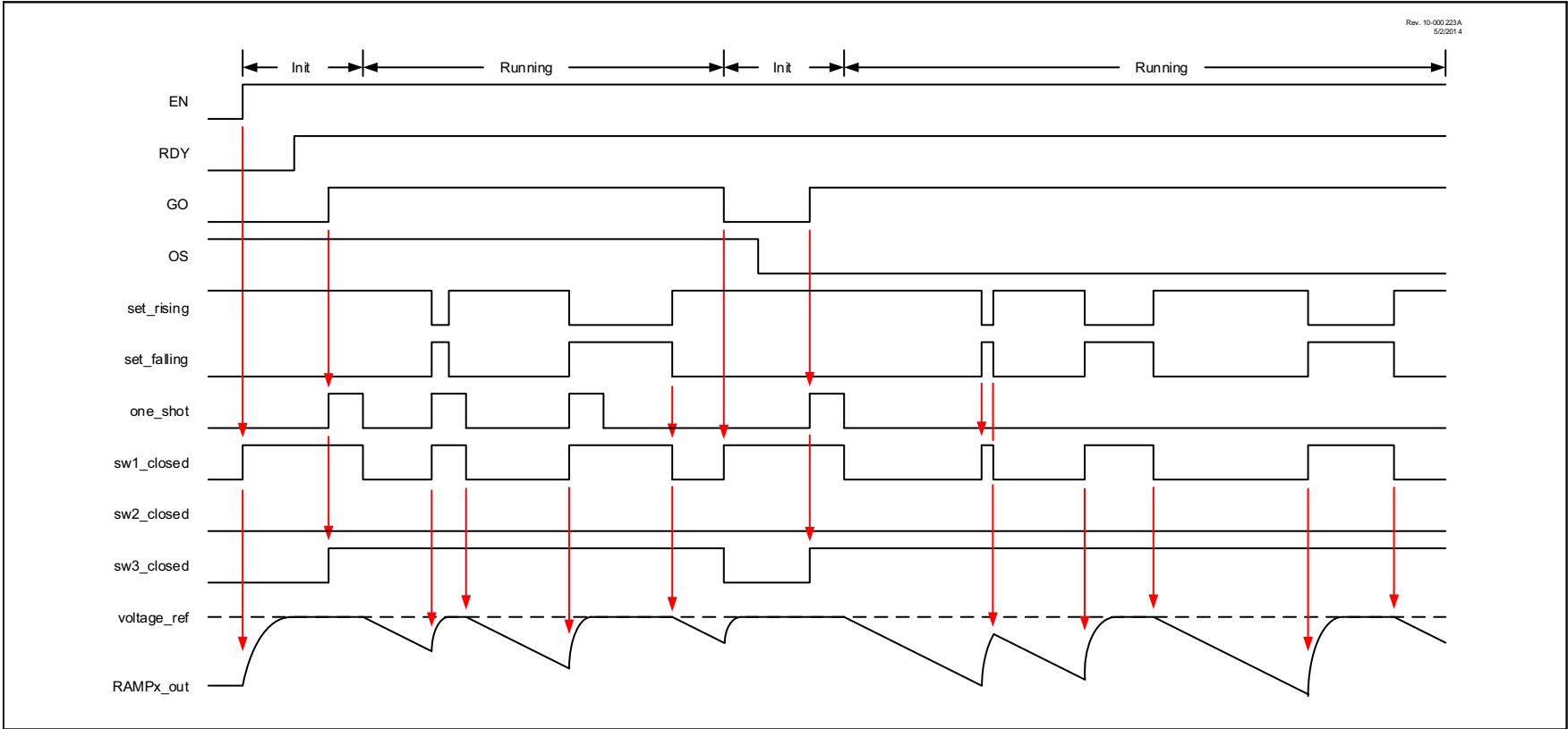
## 30.8 Effects of a Reset

The PRG module resets to a disabled condition.

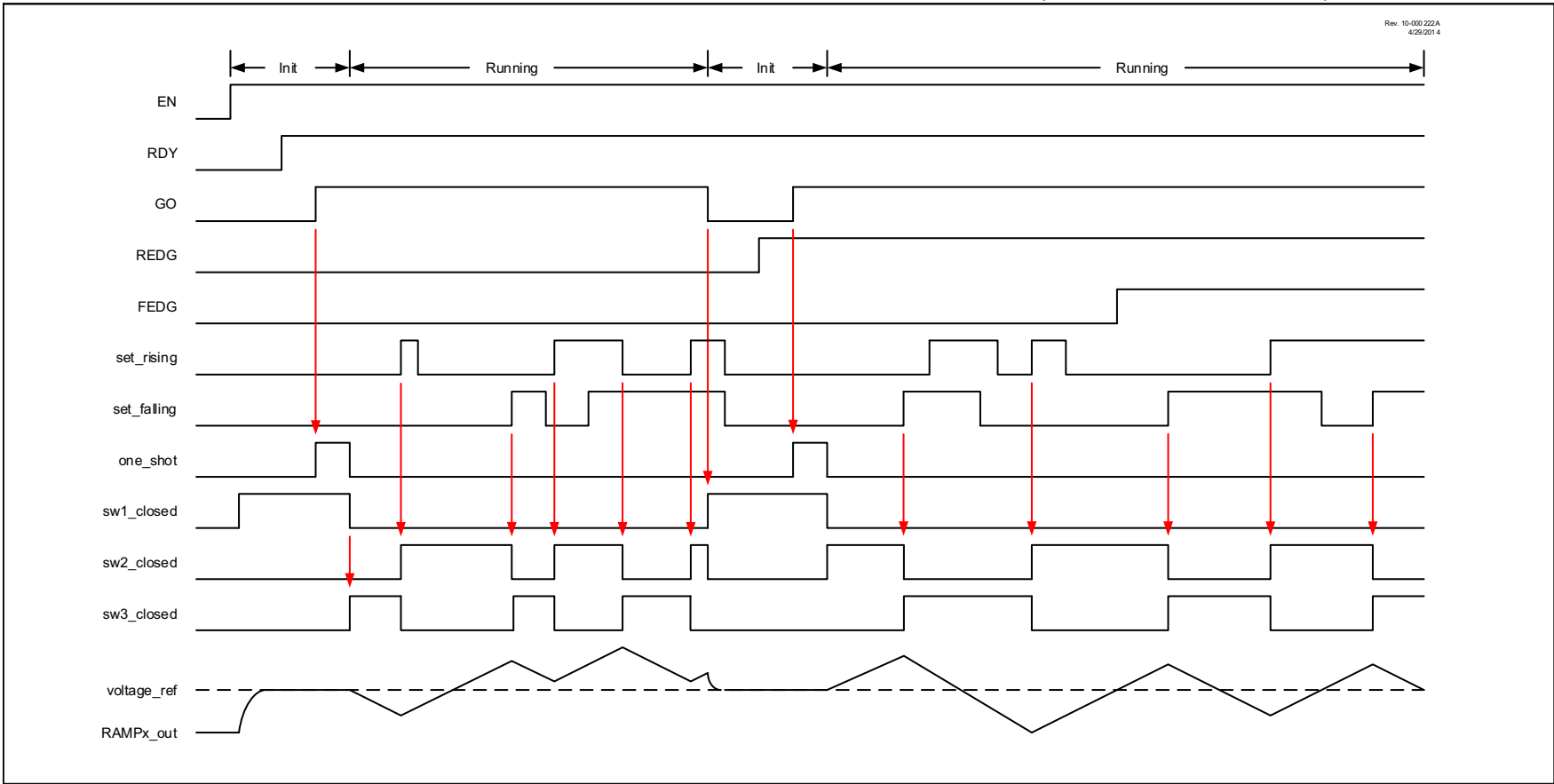
FIGURE 30-1: SIMPLIFIED PRG MODULE BLOCK DIAGRAM



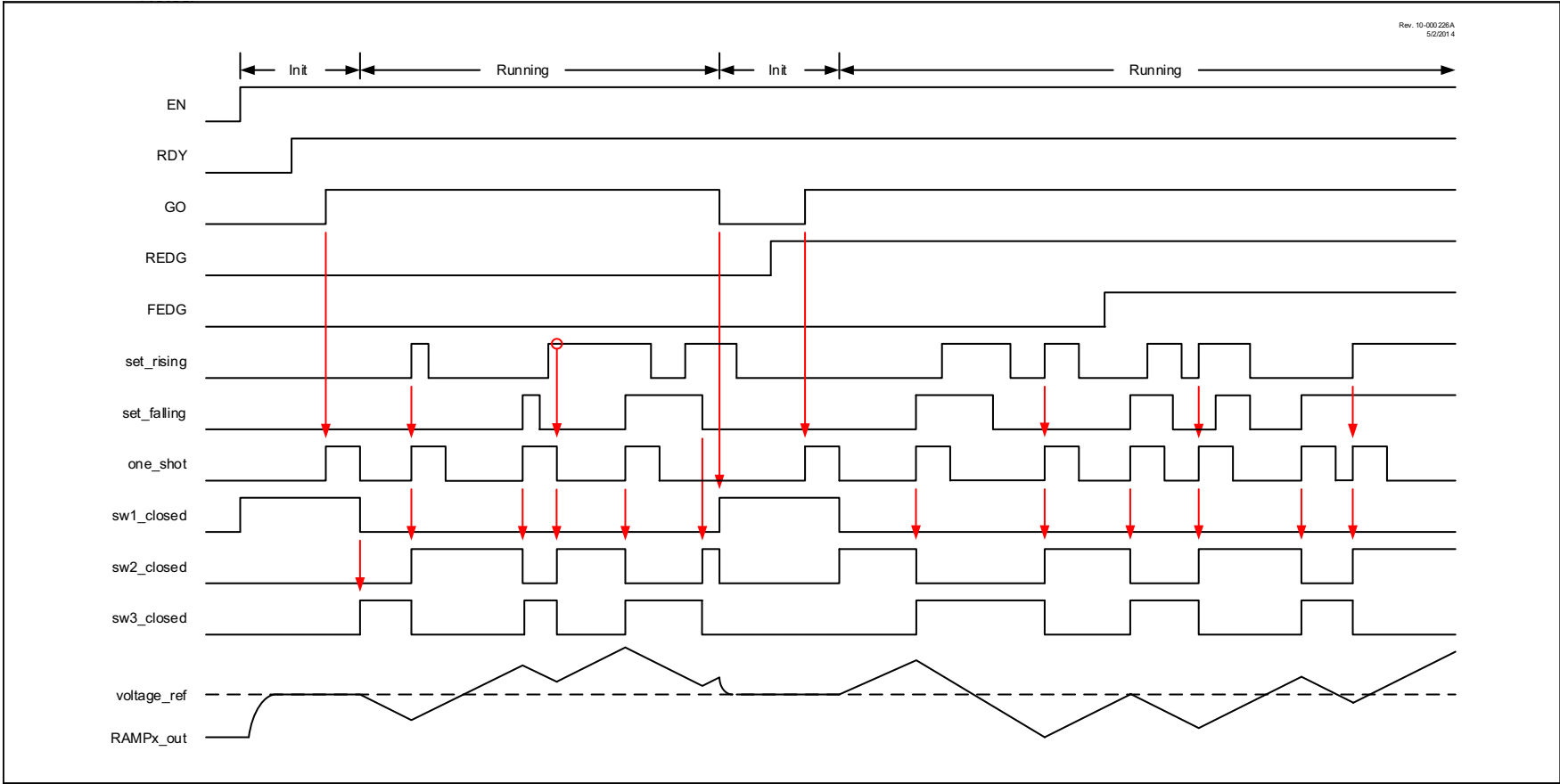
**FIGURE 30-2: SLOPE COMPENSATION (FALLING RAMP) TIMING DIAGRAM (MODE<1:0> = 00)**



**FIGURE 30-3: ALTERNATING RISING/FALLING RAMP GENERATION TIMING DIAGRAM (OS = 0, MODE<1:0> = 01)**



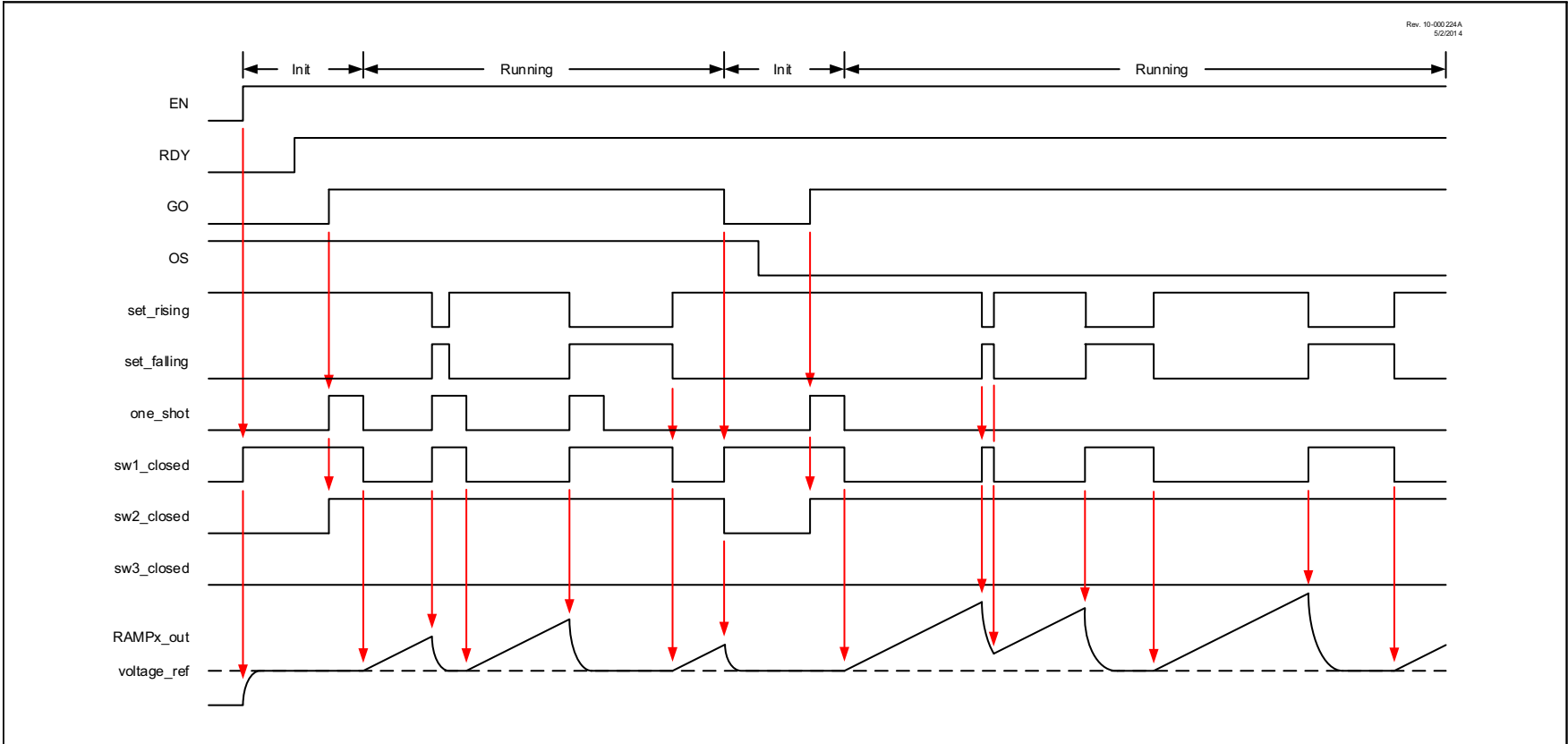
**FIGURE 30-4: ALTERNATING RISING/FALLING RAMP GENERATION TIMING DIAGRAM (OS = 1, MODE<1:0> = 01)**





**FIGURE 30-5: RISING RAMP GENERATION TIMING DIAGRAM (MODE<1:0> = 10)**

Rev. 10-000224A  
5/2/2014



## 30.9 Slope Compensation Application

An example slope compensation circuit is shown in Figure 30-6. The PRG input voltage is PRGxIN which shares an I/O pin with the op amp output. The op amp output is designed to operate at the expected peak current sense voltage, which we'll call VREF. The PRG output voltage starts at VREF and should fall at a rate less than half the target circuit current sense voltage rate of rise. Therefore, the compensator slope, expressed as volts per μs, can be computed by Equation 30-1.

**EQUATION 30-1: COMPENSATOR SLOPE**

$$\frac{V}{\mu s} \geq \frac{\frac{V_{REF}}{2}}{PWM\ Period\ (\mu s)}$$

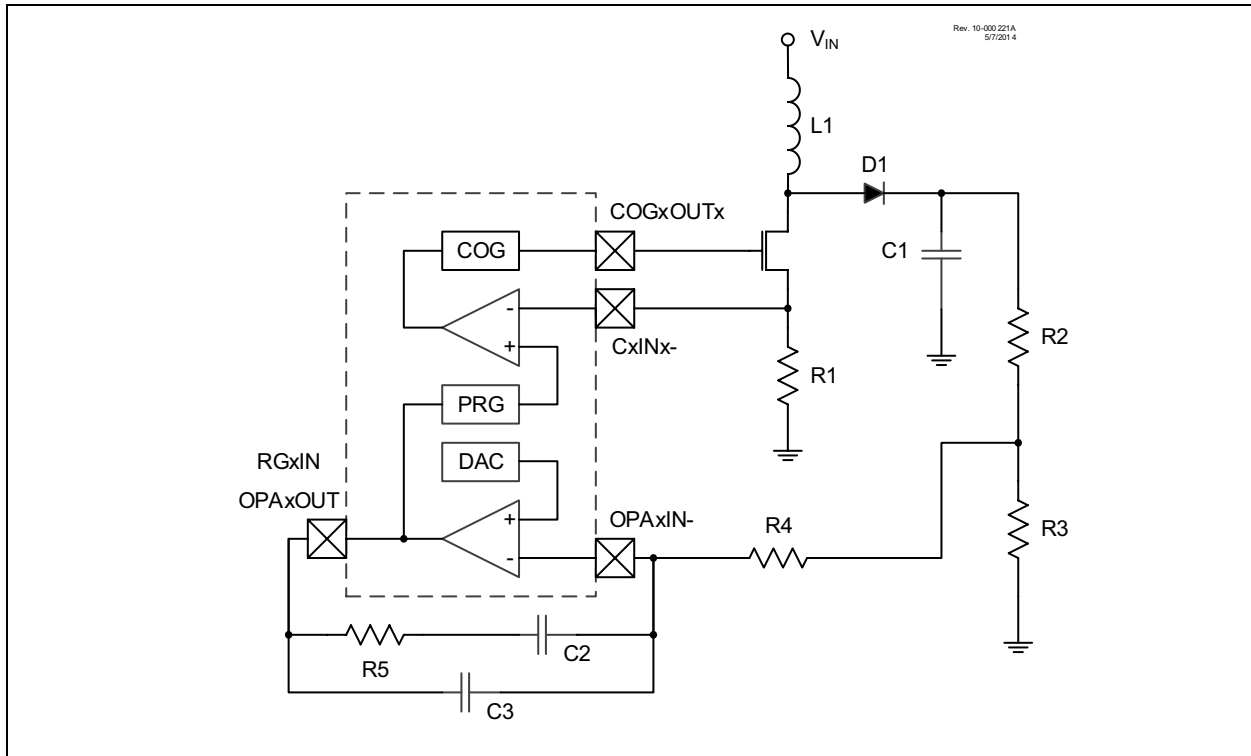
For example, when the circuit is using a 1Ω current sense resistor and the peak current is 1A, then the peak current expressed as a voltage is 1V. Therefore, for this example the op amp output should be designed to operate at 1V. If the power supply PWM frequency is 1 MHz, then the period is 1 μs. Therefore, the desired slope is 0.5 V/μs, which is computed as shown in Equation 30-2.

**EQUATION 30-2: CALCULATION EXAMPLE**

$$\frac{\frac{V_{REF}}{2}}{PWM\ Period\ (\mu s)} = \frac{\frac{1}{2}}{1\ \mu s} = 0.5V/\mu s$$

**Note:** The setting for 0.5V/μs is ISET<4:0> = 6, LR = 0.

**FIGURE 30-6: EXAMPLE SLOPE COMPENSATION CIRCUIT**



## 30.10 Register Definitions: Programmable Ramp Generator

Long bit name prefixes for the PRG peripherals are shown in Table 30-1. Refer to Section 1.1 “Register and Bit Naming Conventions” for more information.

**TABLE 30-1: BIT NAME PREFIXES**

Peripheral	Bit Name Prefix
PRG1	RG1
PRG2 <sup>(1)</sup>	RG2

**Note 1:** PIC16(L)F1768/9 devices only.

### REGISTER 30-1: PRG<sub>x</sub>CON0: PROGRAMMABLE RAMP GENERATOR x CONTROL 0 REGISTER

R/W-0/0	U-0	R/W-0/0	R/W-0/0	R/W-0/0	R/W-0/0	R/W-0/0	R/W-0/0
EN	—	FEDG	REDG	MODE<1:0>	OS	GO	
bit 7						bit 0	

**Legend:**

R = Readable bit	W = Writable bit	U = Unimplemented bit, read as '0'
u = Bit is unchanged	x = Bit is unknown	U = Unimplemented bit, read as '0'
'1' = Bit is set	'0' = Bit is cleared	-n/n = Value at POR and BOR/Value at all other Resets

- bit 7      **EN:** Programmable Ramp Generator Enable bit
  - 1 = PRG module is enabled
  - 0 = PRG module is disabled
- bit 6      **Unimplemented:** Read as '0'
- bit 5      **FEDG:** set\_falling Input Mode Select bit
  - 1 = set\_falling timing input is edge-sensitive
  - 0 = set\_falling timing input is level-sensitive
- bit 4      **REDG:** set\_rising Input Mode Select bit
  - 1 = set\_rising timing input is edge-sensitive
  - 0 = set\_rising timing input is level-sensitive
- bit 3-2    **MODE<1:0>:** Programmable Ramp Generator Mode Selection bits
  - 11 = Reserved
  - 10 = Rising Ramp Generator
  - 01 = Alternating Rising/Falling Ramp Generator
  - 00 = Slope Compensation
- bit 1      **OS:** One-Shot Enable bit
  - 1 = One-shot is enabled; minimum capacitor discharge is internally timed by one-shot
  - 0 = One-shot is disabled; capacitor is discharged when timing input is true
- bit 0      **GO:** Ramp Generation Control Start bit
  - If EN = 0:  
This bit is forced to '0'.
  - If EN = 1:  
1 = Slope or ramp function is operating  
0 = Slope or ramp function is not operating; all current source switches are open and capacitor discharge switch is closed

# PIC16(L)F1764/5/8/9

## REGISTER 30-2: PRGxCON1: PROGRAMMABLE RAMP GENERATOR x CONTROL 1 REGISTER

U-0	U-0	U-0	U-0	U-0	R-0	R/W-0/0	R/W-0/0
—	—	—	—	—	RDY	FPOL	RPOL
bit 7						bit 0	

### Legend:

R = Readable bit                      W = Writable bit  
u = Bit is unchanged                  x = Bit is unknown                  U = Unimplemented bit, read as '0'  
'1' = Bit is set                          '0' = Bit is cleared                  -n/n = Value at POR and BOR/Value at all other Resets

- bit 7-3            **Unimplemented:** Read as '0'
- bit 2            **RDY:** Slope Generator Ready Status bit  
1 = PRG is ready  
0 = PRG is not ready
- bit 1            **FPOL:** Fall Event Polarity Select bit  
1 = set\_falling timing input is active-low  
0 = set\_falling timing input is active-high
- bit 0            **RPOL:** Rise Event Polarity Select bit  
1 = set\_rising timing input is active-low  
0 = set\_rising timing input is active-high

## REGISTER 30-3: PRGxINS: PRGx VOLTAGE INPUT SELECT REGISTER

U-0	U-0	U-0	U-0	R/W-0/0	R/W-0/0	R/W-0/0	R/W-0/0
—	—	—	—	INS<3:0>			
bit 7						bit 0	

### Legend:

R = Readable bit                      W = Writable bit  
u = Bit is unchanged                  x = Bit is unknown                  U = Unimplemented bit, read as '0'  
'1' = Bit is set                          '0' = Bit is cleared                  -n/n = Value at POR and BOR/Value at all other Resets

- bit 7-4            **Unimplemented:** Read as '0'
- bit 3-0            **INS<3:0>:** Voltage Input Select bits  
Selects source of voltage level at which the ramp starts. See [Table 30-2](#).

# PIC16(L)F1764/5/8/9

**TABLE 30-2: VOLTAGE INPUT SOURCES**

INS<2:0>	PIC16(L)F1764/5 Voltage Source		PIC16(L)F1768/9 Voltage Source	
1010-1111	Reserved	Reserved	Reserved	Reserved
1001 <sup>(1)</sup>	Reserved	Switched PRG1IN1/OPA2OUT	Switched PRG2IN1/OPA1OUT	
1000 <sup>(1)</sup>	Switched PRG1IN0/OPA1OUT	Switched PRG1IN0/OPA1OUT	Switched PRG2IN0/OPA2OUT	
0111	Reserved	Reserved	Reserved	
0110	Reserved	DAC4_output	DAC4_output	
0101	DAC3_output	DAC3_output	DAC3_output	
0100	Reserved	DAC2_output	DAC2_output	
0011	DAC1_output	DAC1_output	DAC1_output	
0010	FVR_buffer2	FVR_buffer2	FVR_buffer2	
0001	Reserved	PRG1IN1/OPA2OUT	PRG2IN1/OPA1OUT	
0000	PRG1IN0/OPA1OUT	PRG1IN0/OPA1OUT	PRG2IN0/OPA2OUT	

**Note 1:** Input source is switched off when op amp override is forcing tri-state. See [Section 29.3 “Override Control”](#).

# PIC16(L)F1764/5/8/9

## REGISTER 30-4: PRGxCON2: PROGRAMMABLE RAMP GENERATOR x CONTROL 2 REGISTER

R/W-0/0	U-0	U-0	R/W-0/0	R/W-0/0	R/W-0/0	R/W-0/0	R/W-0/0
LR <sup>(1)</sup>	—	—	ISET<4:0>				
bit 7							bit 0

### Legend:

R = Readable bit

W = Writable bit

u = Bit is unchanged

x = Bit is unknown

U = Unimplemented bit, read as '0'

'1' = Bit is set

'0' = Bit is cleared

-n/n = Value at POR and BOR/Value at all other Resets

- bit 7      **LR:** PRG Current Source/Sink Low Range Enable bit<sup>(1)</sup>
- bit 6-5    **Unimplemented:** Read as '0'
- bit 4-0    **ISET<4:0>:** PRG Current Source/Sink Set bits  
Current source/sink setting and slope rate. See [Table 30-3](#).

**Note 1:** Available on PIC16(L)F1768/9 only.

**TABLE 30-3: PROGRAMMABLE RAMP GENERATOR CURRENT SETTINGS**

ISET<4:1>	LR = 0		LR = 1	
	Current Setting ( $\mu\text{A}$ )	Slope Rate ( $\text{V}/\mu\text{s}$ )	Current Setting ( $\mu\text{A}$ )	Slope Rate ( $\text{V}/\mu\text{s}$ )
0h	2	0.2	0.44	0.04
1h	2.5	0.25	0.56	0.06
2h	3	0.3	0.67	0.07
3h	3.5	0.35	0.78	0.08
4h	4	0.4	0.89	0.09
5h	4.5	0.45	1.00	0.10
6h	5	0.5	1.11	0.11
7h	5.5	0.55	1.22	0.12
8h	6	0.6	1.33	0.13
9h	6.5	0.65	1.44	0.14
Ah	7	0.7	1.56	0.16
Bh	7.5	0.75	1.67	0.17
Ch	8	0.8	1.78	0.18
Dh	8.5	0.85	1.89	0.19
Eh	9	0.9	2.00	0.20
Fh	9.5	0.95	2.11	0.21
10h	10	1.0	2.22	0.22
11h	11	1.1	2.44	0.24
12h	12	1.2	2.67	0.27
13h	13	1.3	2.89	0.29
14h	14	1.4	3.11	0.31
15h	15	1.5	3.33	0.33
16h	16	1.6	3.56	0.36
17h	17	1.7	3.78	0.38
18h	18	1.8	4.00	0.40
19h	19	1.9	4.22	0.42
1Ah	20	2.0	4.44	0.44
1Bh	21	2.1	4.67	0.47
1Ch	22	2.2	4.89	0.49
1Dh	23	2.3	5.11	0.51
1Eh	24	2.4	5.33	0.53
1Fh	25	2.5	5.56	0.56

# PIC16(L)F1764/5/8/9

**REGISTER 30-5: PRGxRTSS: PRGx set\_rising TIMING SOURCE SELECT REGISTER**

U-0	U-0	U-0	U-0	R/W-0/0	R/W-0/0	R/W-0/0	R/W-0/0
—	—	—	—	RTSS<3:0>			
bit 7				bit 0			

**Legend:**

R = Readable bit	W = Writable bit	
u = Bit is unchanged	x = Bit is unknown	U = Unimplemented bit, read as '0'
'1' = Bit is set	'0' = Bit is cleared	-n/n = Value at POR and BOR/Value at all other Resets

bit 7-4      **Unimplemented:** Read as '0'  
bit 3-0      **RTSS<3:0>:** set\_rising Timing Source Select bits  
See [Table 30-4](#).

**REGISTER 30-6: PRGxFTSS: PRGx set\_falling TIMING SOURCE SELECT REGISTER**

U-0	U-0	U-0	U-0	R/W-0/0	R/W-0/0	R/W-0/0	R/W-0/0
—	—	—	—	FTSS<3:0>			
bit 7				bit 0			

**Legend:**

R = Readable bit	W = Writable bit	
u = Bit is unchanged	x = Bit is unknown	U = Unimplemented bit, read as '0'
'1' = Bit is set	'0' = Bit is cleared	-n/n = Value at POR and BOR/Value at all other Resets

bit 7-4      **Unimplemented:** Read as '0'  
bit 3-0      **FTSS<3:0>:** set\_falling Timing Source Select bits  
See [Table 30-4](#).

**TABLE 30-4: PROGRAMMABLE RAMP GENERATOR TIMING SOURCES**

RTSS<3:0>/FTSS<3:0>	Timing Source	RTSS<3:0>/FTSS<3:0>	Timing Source
0000	sync_C1OUT	1000	PWM6_output <sup>(2)</sup>
0001	sync_C2OUT	1001	CCP1_out
0010	sync_C3OUT <sup>(2)</sup>	1010	CCP2_out <sup>(2)</sup>
0011	sync_C4OUT <sup>(2)</sup>	1011	Reserved
0100	PRGxR/PRGxF Pin <sup>(1)</sup>	1100	Reserved
0101	PWM3_output	1101	Reserved
0110	PWM4_output <sup>(2)</sup>	1110	Reserved
0111	PWM5_output	1111	Reserved

**Note 1:** Input pin is selected with the PRGxRPPS or PRGxFPPS register.

**2:** PIC16(L)F1768/9 only.



# PIC16(L)F1764/5/8/9

**TABLE 30-5: SUMMARY OF REGISTERS ASSOCIATED WITH THE PRG MODULE**

Name	Bit 7	Bit 6	Bit 5	Bit 4	Bit 3	Bit 2	Bit 1	Bit 0	Register on Page
PRG1CON0	EN	—	FEDG	REDG	MODE<1:0>		OS	GO	363
PRG1CON1	—	—	—	—	—	RDY	FPOL	RPOL	364
PRG1CON2	LR <sup>(2)</sup>	—	—	ISET<4:0>					366
PRG1INS	—	—	—	—	INS<3:0>				364
PRG1RPPS	—	—	—	PRG1RPPS<4:0>					368
PRG1FPPS	—	—	—	PRG1FPPS<4:0>					368
PRG1RTSS	—	—	—	—	RTSS<3:0>				156, 158
PRG1FTSS	—	—	—	—	FTSS<3:0>				156, 158
PRG2CON0 <sup>(1)</sup>	EN	—	FEDG	REDG	MODE<1:0>		OS	GO	363
PRG2CON1 <sup>(1)</sup>	—	—	—	—	—	RDY	FPOL	RPOL	364
PRG2CON2 <sup>(1)</sup>	LR	—	—	ISET<4:0>					366
PRG2INS <sup>(1)</sup>	—	—	—	—	INS<3:0>				364
PRG2RPPS <sup>(1)</sup>	—	—	—	PRG2RPPS<4:0>					368
PRG2FPPS <sup>(1)</sup>	—	—	—	PRG2FPPS<4:0>					368
PRG2RTSS <sup>(1)</sup>	—	—	—	—	RTSS<3:0>				156, 158
PRG2FTSS <sup>(1)</sup>	—	—	—	—	FTSS<3:0>				156, 158
PORTC	RC<7:6> <sup>(1)</sup>		RC<5:0>						149
TRISC	TRISC<7:6> <sup>(1)</sup>		TRISC<5:4>		TRISC<3:2>		TRISC<1:0>		149
ANSEL	ANSC<7:6> <sup>(1)</sup>		—	—	ANSC<3:2>		ANSC<1:0>		150
WPUC	WPUC<7:6> <sup>(1)</sup>		WPUC<5:4>		WPUC<3:2>		WPUC<1:0>		151

**Legend:** — = unimplemented, read as '0'. Shaded cells are unused by the PRG module.

**Note 1:** PIC16(L)F1768/9 only.

## 31.0 DATA SIGNAL MODULATOR (DSM)

The Data Signal Modulator (DSM) is a peripheral that allows the user to mix a data stream, also known as a modulator signal, with a carrier signal to produce a modulated output.

Both the carrier and the modulator signals are supplied to the DSM module either internally, from the output of a peripheral, or externally through an input pin.

The modulated output signal is generated by performing a logical “AND” operation of both the carrier and modulator signals and then provided to the MDxOUT pin.

The carrier signal is comprised of two distinct and separate signals: a Carrier High (CARH) signal and a Carrier Low (CARL) signal. During the time in which the Modulator (MOD) signal is in a logic high state, the DSM mixes the Carrier High signal with the Modulator signal. When the Modulator signal is in a logic low state, the DSM mixes the Carrier Low signal with the Modulator signal.

Using this method, the DSM can generate the following types of key modulation schemes:

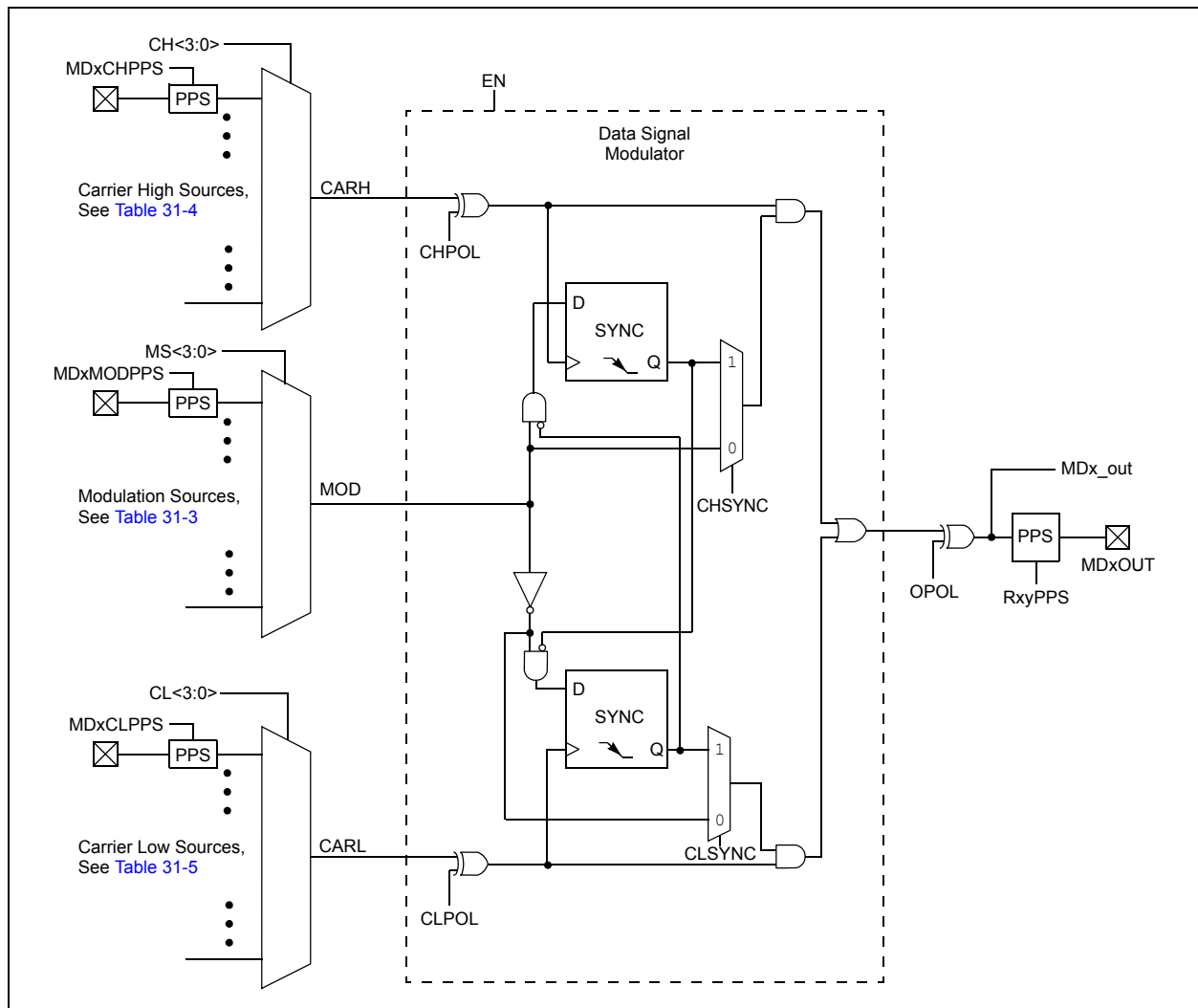
- Frequency-Shift Keying (FSK)
- Phase-Shift Keying (PSK)
- On-Off Keying (OOK)

Additionally, the following features are provided within the DSM module:

- Carrier Synchronization
- Carrier Source Polarity Select
- Carrier Source Pin Disable
- Programmable Modulator Data
- Modulator Source Pin Disable
- Modulated Output Polarity Select
- Slew Rate Control

Figure 31-1 shows a simplified block diagram of the Data Signal Modulator peripheral.

**FIGURE 31-1: SIMPLIFIED BLOCK DIAGRAM OF THE DATA SIGNAL MODULATOR**



## 31.1 DSM Operation

The DSM module is enabled by setting the EN bit in the MDxCON register. Clearing the EN bit in the MDxCON register, disables the DSM module by automatically switching the Carrier High and Carrier Low signals to the Vss signal source. The Modulator signal source is also switched to the BIT bit in the MDxCON0 register. This not only assures that the DSM module is inactive, but that it is also consuming the least amount of current.

The values used to select the Carrier High, Carrier Low and Modulator sources held by the Modulation Source, Modulation High Carrier and Modulation Low Carrier registers are not affected when the EN bit is cleared, and the DSM module is disabled. The values inside these registers remain unchanged while the DSM is inactive. The sources for the Carrier High, Carrier Low and Modulator signals will once again be selected when the EN bit is set and the DSM module is enabled and active.

The modulated output signal can be output on any device I/O pin by selecting the desired DSM module in the pin's PPS Control register (see [Register 12-2](#)). If the output is not directed to any I/O pin, then the DSM module will remain active and continue to mix signals, but the output value will not be sent to any pin.

## 31.2 Modulator Signal Sources

The Modulator signal is selected by configuring the MS<4:0> bits of the MDxSRC register. Selections are shown in [Table 31-3](#).

## 31.3 Carrier Signal Sources

The Carrier High signal is selected by configuring the CH<3:0> bits of the MDxCARH register. Selections are shown in [Table 31-4](#).

The Carrier Low signal is selected by configuring the CL<3:0> bits of the MDxCARL register. Selections are shown in [Table 31-5](#).

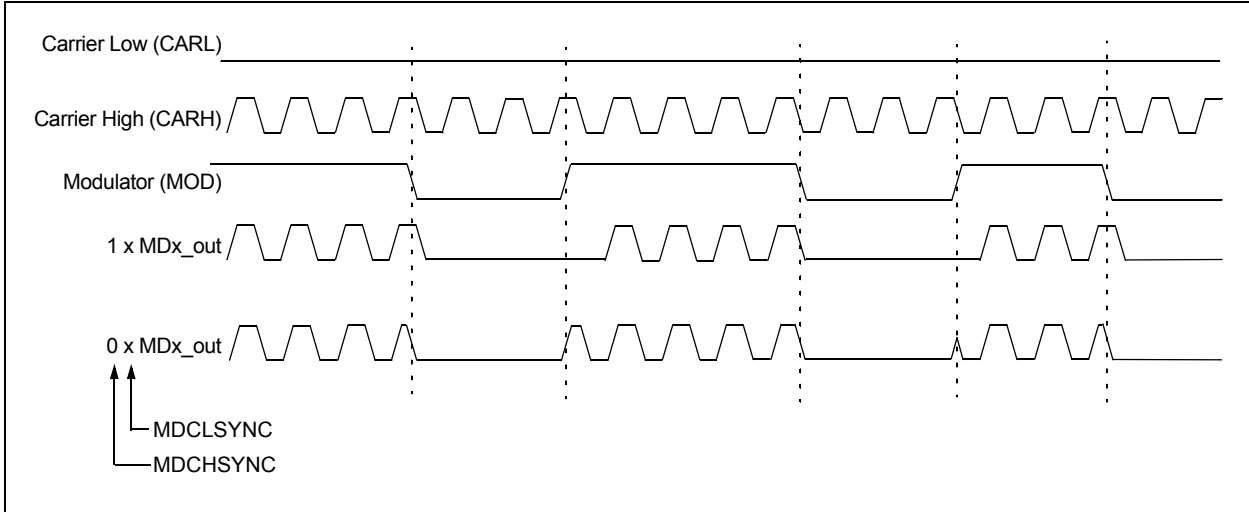
## 31.4 Carrier Synchronization

During the time when the DSM switches between Carrier High and Carrier Low signal sources, the carrier data in the modulated output signal can become truncated. To prevent this, the carrier signal can be synchronized to the Modulator signal. When synchronization is enabled, the carrier pulse that is being mixed at the time of the transition is allowed to transition low before the DSM switches over to the next carrier source.

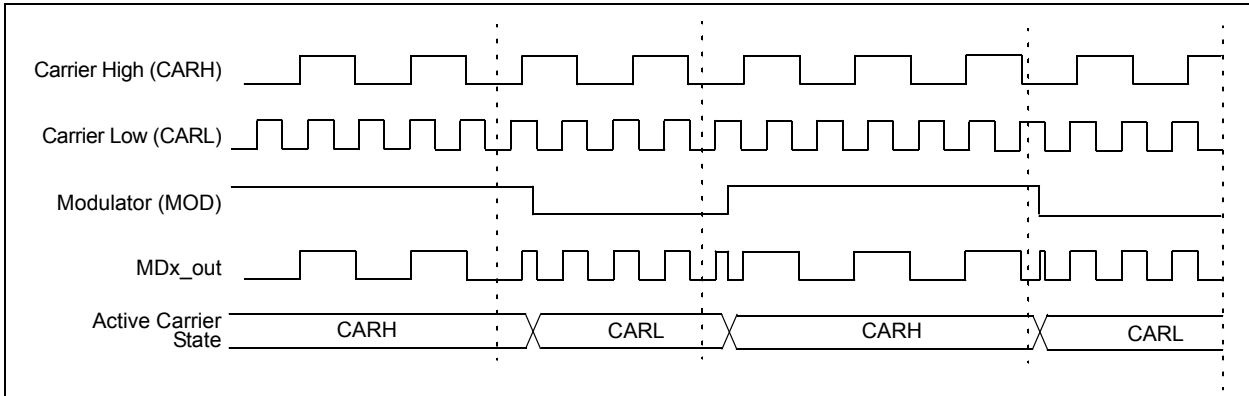
Synchronization is enabled separately for the Carrier High and Carrier Low signal sources. Synchronization for the Carrier High signal is enabled by setting the CHSYNC bit of the MDxCON1 register. Synchronization for the Carrier Low signal is enabled by setting the CLSYNC bit of the MDxCON1 register.

[Figure 31-1](#) through [Figure 31-6](#) show timing diagrams of using various synchronization methods.

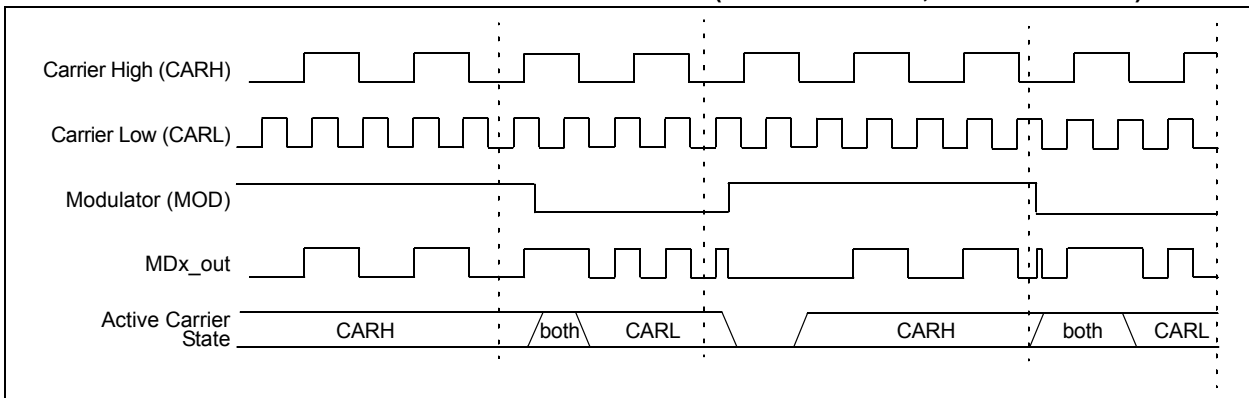
**FIGURE 31-2: ON-OFF KEYING (OOK) SYNCHRONIZATION**



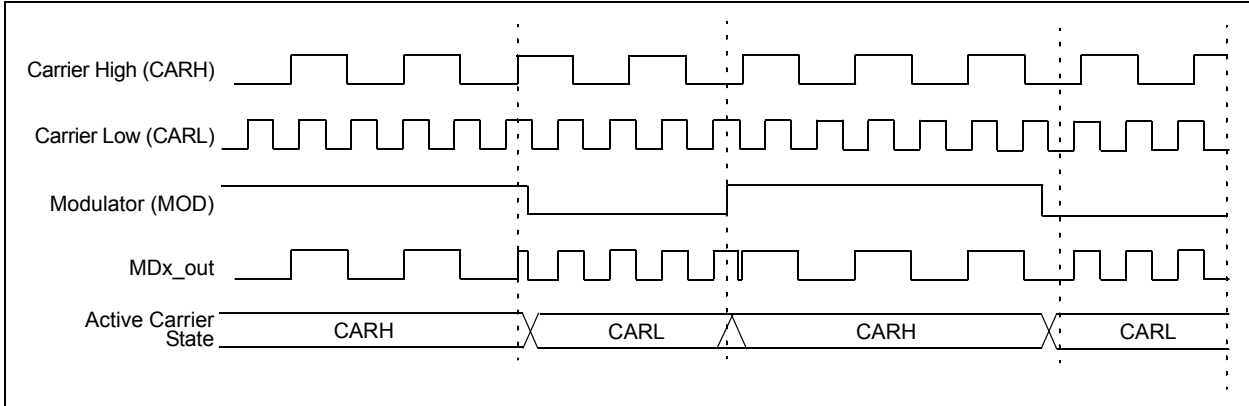
**FIGURE 31-3: NO SYNCHRONIZATION (MDCHSYNC = 0, MDCLSYNC = 0)**



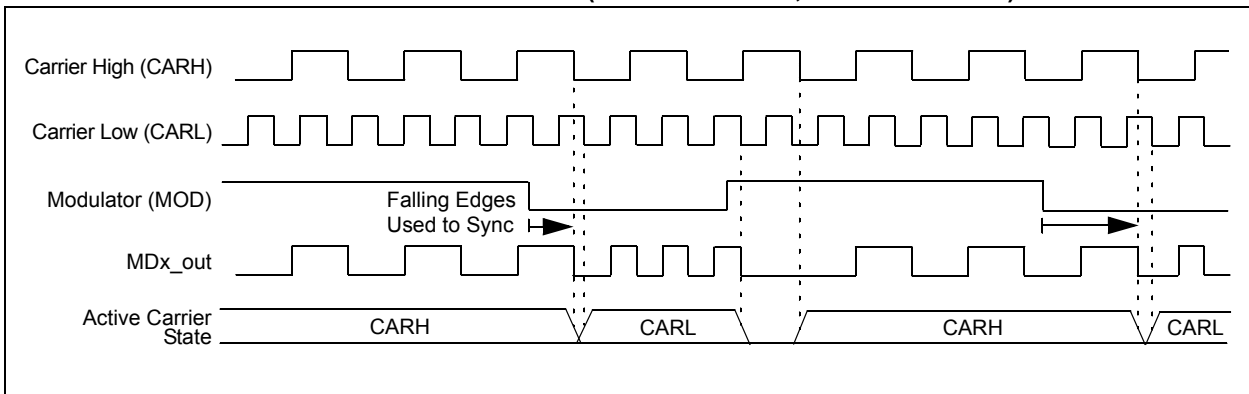
**FIGURE 31-4: CARRIER HIGH SYNCHRONIZATION (MDCHSYNC = 1, MDCLSYNC = 0)**



**FIGURE 31-5: CARRIER LOW SYNCHRONIZATION (MDCHSYNC = 0, MDCLSYNC = 1)**



**FIGURE 31-6: FULL SYNCHRONIZATION (MDCHSYNC = 1, MDCLSYNC = 1)**



## 31.5 Input and Output Through Pins

The modulation and carrier sources may be selected to come from any device pin with the PPS control logic. Selecting a pin requires two settings: the source selection determines that the PPS will be used and the PPS control selects the desired pin. Source and PPS registers are identified in [Table 31-1](#). PPS register pin selections are shown in [Register 12-1](#) and [Register 12-2](#).

**TABLE 31-1: PIN SELECTIONS**

Source	Source Register	PPS Register
Modulation	MDxSRC	MDxMODPPS
Carrier High	MDxCARH	MDxCHPPS
Carrier Low	MDxCARL	MDxCLPPS

Any device pin can be selected as the modulation output with the individual pin PPS controls. See [Register 12-2](#) for the pin output selections.

## 31.6 Carrier Source Polarity Select

The signal provided from any selected input source for the Carrier High and Carrier Low signals can be inverted. Inverting the signal for the Carrier High source is enabled by setting the CHPOL bit of the MDxCON1 register. Inverting the signal for the Carrier Low source is enabled by setting the CLPOL bit of the MDxCON1 register.

## 31.7 Programmable Modulator Data

The BIT bit of the MDxCON0 register can be selected as the source for the Modulator signal. When the BIT source is selected, then software generates the Modulation signal by setting and clearing the BIT bit at the respective desired modulation high and low times.

## 31.8 Modulated Output Polarity

The modulated output signal provided on the MDxOUT pin can also be inverted. Inverting the modulated output signal is enabled by setting the OPOL bit of the MDxCON0 register.

## 31.9 Operation in Sleep Mode

The DSM module is not affected by Sleep mode. The DSM will operate during Sleep provided that the carrier and modulator input sources are also active during Sleep.

## 31.10 Effects of a Reset

Upon any device Reset, the Data Signal Modulator module is disabled. The user's firmware is responsible for initializing the module before enabling the output. The registers are reset to their default values.

## 31.11 Register Definitions: Data Signal Modulator

Long bit name prefixes for the DSM peripherals are shown in Table 31-2. Refer to Section 1.1.2.2 “Long Bit Names” for more information.

**TABLE 31-2: BIT NAME PREFIXES**

Peripheral	Bit Name Prefix
DSM1	MD1
DSM2 <sup>(1)</sup>	MD2

**Note 1:** PIC16(L)F1768/9 devices only.

### REGISTER 31-1: MDxCON0: MODULATION x CONTROL REGISTER 0

R/W-0/0	U-0	R-0/0	R/W-0/0	U-0	U-0	U-0	R/W-0/0
EN	—	OUT	OPOL	—	—	—	BIT <sup>(2)</sup>
bit 7							bit 0

**Legend:**

R = Readable bit	W = Writable bit	
u = Bit is unchanged	x = Bit is unknown	U = Unimplemented bit, read as '0'
'1' = Bit is set	'0' = Bit is cleared	-n/n = Value at POR and BOR/Value at all other Resets

- bit 7      **EN:** Modulator Module Enable bit  
           1 = Modulator module is enabled and mixing input signals  
           0 = Modulator module is disabled and has no output
- bit 6      **Unimplemented:** Read as '0'
- bit 5      **OUT:** Modulator Output bit  
           Displays the current output value of the modulator module.<sup>(1)</sup>
- bit 4      **OPOL:** Modulator Output Polarity Select bit  
           1 = Modulator output signal is inverted; Idle high output  
           0 = Modulator output signal is not inverted; Idle low output
- bit 3-1    **Unimplemented:** Read as '0'
- bit 0      **BIT:** Direct Software Control of the Modulation Source Input to Module bit<sup>(2)</sup>  
           1 = Modulator uses Carrier High source  
           0 = Modulator uses Carrier Low source

**Note 1:** The modulated output frequency can be greater and asynchronous from the clock that updates this register bit; the bit value may not be valid for higher speed modulator or carrier signals.

**2:** BIT must be selected as the modulation source in the MDxSRC register for this operation.

# PIC16(L)F1764/5/8/9

## REGISTER 31-2: MDxCON1: MODULATION x CONTROL REGISTER 1

U-0	U-0	R/W-0/0	R/W-0/0	U-0	U-0	R/W-0/0	R/W-0/0
—	—	CHPOL	CHSYNC	—	—	CLPOL	CLSYNC
bit 7						bit 0	

### Legend:

R = Readable bit

W = Writable bit

u = Bit is unchanged

x = Bit is unknown

U = Unimplemented bit, read as '0'

'1' = Bit is set

'0' = Bit is cleared

-n/n = Value at POR and BOR/Value at all other Resets

bit 7-6 **Unimplemented:** Read as '0'

bit 5 **CHPOL:** Modulation High Carrier Polarity Select bit

1 = Selected high carrier source is inverted

0 = Selected high carrier source is not inverted

bit 4 **CHSYNC:** Modulation High Carrier Synchronization Enable bit

1 = Modulator waits for a low edge on the high carrier before allowing a switch to the low carrier

0 = Modulator output is not synchronized to the high carrier<sup>(1)</sup>

bit 3-2 **Unimplemented:** Read as '0'

bit 1 **CLPOL:** Modulation Low Carrier Polarity Select bit

1 = Selected low carrier source is inverted

0 = Selected low carrier source is not inverted

bit 0 **CLSYNC:** Modulation Low Carrier Synchronization Enable bit

1 = Modulator waits for a low edge on the low carrier before allowing a switch to the high carrier

0 = Modulator output is not synchronized to the low carrier<sup>(1)</sup>

**Note 1:** Narrowed carrier pulse widths or spurs may occur in the signal stream if the carrier is not synchronized.



# PIC16(L)F1764/5/8/9

**REGISTER 31-3: MDxSRC: MODULATION x SOURCE CONTROL REGISTER**

U-0	U-0	U-0	R/W-x/u	R/W-x/u	R/W-x/u	R/W-x/u	R/W-x/u
—	—	—	MS<4:0>				
bit 7							bit 0

**Legend:**

R = Readable bit                      W = Writable bit  
u = Bit is unchanged                  x = Bit is unknown                  U = Unimplemented bit, read as '0'  
'1' = Bit is set                            '0' = Bit is cleared                  -n/n = Value at POR and BOR/Value at all other Resets

bit 7-5                    **Unimplemented:** Read as '0'  
bit 4-0                    **MS<4:0>** Modulation Source Selection bits  
See [Table 31-3](#).

**TABLE 31-3: MODULATION SOURCE**

MS<4:0>	Modulation Source PIC16(L)F1764/5	Modulation Source PIC16(L)F1768/9
11111-10100	Fixed Low	Fixed Low
10011	Fixed Low	sync_C4OUT
10010	Fixed Low	sync_C3OUT
10001	sync_C2OUT	sync_C2OUT
10000	sync_C1OUT	sync_C1OUT
01111	LC3_out	LC3_out
01110	LC2_out	LC2_out
01101	LC1_out	LC1_out
01100	Fixed Low	PWM6_out
01011	PWM5_out	PWM5_out
01010	Fixed Low	PWM4_out
01001	PWM3_out	PWM3_out
01000	Fixed low	CCP2_out
00111	CCP1_out	CCP1_out
00110	SDO_out	SDO_out
00101	Fixed Low	COG2A
00100	DT	DT
00011	TX_out	TX_out
00010	COG1A	COG1A
00001	MDxBIT	MDxBIT
00000	MDxMODPPS Pin Selection	MDxMODPPS Pin Selection

# PIC16(L)F1764/5/8/9

## REGISTER 31-4: MDxCARH: MODULATION x CARRIER HIGH CONTROL REGISTER

U-0	U-0	U-0	U-0	R/W-x/u	R/W-x/u	R/W-x/u	R/W-x/u
—	—	—	—	CH<3:0> <sup>(1)</sup>			
bit 7				bit 0			

### Legend:

R = Readable bit	W = Writable bit	
u = Bit is unchanged	x = Bit is unknown	U = Unimplemented bit, read as '0'
'1' = Bit is set	'0' = Bit is cleared	-n/n = Value at POR and BOR/Value at all other Resets

bit 7-4      **Unimplemented:** Read as '0'

bit 3-0      **CH<3:0>** Modulator Data High Carrier Selection bits<sup>(1)</sup>

See [Table 31-4](#).

**Note 1:** Narrowed carrier pulse widths or spurs may occur in the signal stream if the carrier is not synchronized.

**TABLE 31-4: HIGH CARRIER SOURCES**

CH<3:0>	High Carrier Source PIC16(L)F1764/5	High Carrier Source PIC16(L)F1768/9
1111	LC3_out	LC3_out
1110	LC2_out	LC2_out
1101	LC1_out	LC1_out
1100	Fixed Low	PWM6_out
1011	PWM5_out	PWM5_out
1010	Fixed Low	PWM4_out
1001	PWM3_out	PWM3_out
1000	Fixed Low	CCP2_out
0111	CCP1_out	CCP1_out
0110	Fixed Low	Fixed Low
0101	Fixed Low	Fixed Low
0100	Fixed Low	Fixed Low
0011	Fixed Low	Fixed Low
0010	HFINTOSC	HFINTOSC
0001	FOSC	FOSC
0000	MDxCHPPS Pin Selection	MDxCHPPS Pin Selection

# PIC16(L)F1764/5/8/9

**REGISTER 31-5: MDxCARL: MODULATION x CARRIER LOW CONTROL REGISTER**

U-0	U-0	U-0	U-0	R/W-x/u	R/W-x/u	R/W-x/u	R/W-x/u
—	—	—	—	CL<3:0> <sup>(1)</sup>			
bit 7				bit 0			

**Legend:**

R = Readable bit	W = Writable bit	U = Unimplemented bit, read as '0'
u = Bit is unchanged	x = Bit is unknown	-n/n = Value at POR and BOR/Value at all other Resets
'1' = Bit is set	'0' = Bit is cleared	

bit 7-4      **Unimplemented:** Read as '0'  
bit 3-0      **CL<3:0>** Modulator Data Low Carrier Selection bits<sup>(1)</sup>  
See [Table 31-5](#).

**Note 1:** Narrowed carrier pulse widths or spurs may occur in the signal stream if the carrier is not synchronized.

**TABLE 31-5: LOW CARRIER SOURCES**

CL<3:0>	Low Carrier Source PIC16(L)F1764/5	Low Carrier Source PIC16(L)F1768/9
1111	LC3_out	LC3_out
1110	LC2_out	LC2_out
1101	LC1_out	LC1_out
1100	Fixed Low	PWM6_out
1011	PWM5_out	PWM5_out
1010	Fixed Low	PWM4_out
1001	PWM3_out	PWM3_out
1000	Fixed Low	CCP2_out
0111	CCP1_out	CCP1_out
0110	Fixed Low	Fixed Low
0101	Fixed Low	Fixed Low
0100	Fixed Low	Fixed Low
0011	Fixed Low	Fixed Low
0010	HFINTOSC	HFINTOSC
0001	Fosc	Fosc
0000	MDxCLPPS Pin Selection	MDxCLPPS Pin Selection

**TABLE 31-6: SUMMARY OF REGISTERS ASSOCIATED WITH DATA SIGNAL MODULATOR MODE**

Name	Bit 7	Bit 6	Bit 5	Bit 4	Bit 3	Bit 2	Bit 1	Bit 0	Register on Page
MDxCARH	—	—	—	—	CH<3:0>				378
MDxCARL	—	—	—	—	CL<3:0>				379
MDxSRC	—	—	—	MS<4:0>					376
MDxCON0	EN	—	OUT	OPOL	—	—	—	BIT	375
MDxCON1	—	—	CHPOL	CHSYNC	—	—	CLPOL	CLSYNC	375

**Legend:** — = unimplemented location, read as '0'. Shaded cells are not used by the Data Signal Modulator.

## 32.0 MASTER SYNCHRONOUS SERIAL PORT (MSSP) MODULE

### 32.1 MSSP Module Overview

The Master Synchronous Serial Port (MSSP) module is a serial interface useful for communicating with other peripheral or microcontroller devices. These peripheral devices may be serial EEPROMs, shift registers, display drivers, A/D converters, etc. The MSSP module can operate in one of two modes:

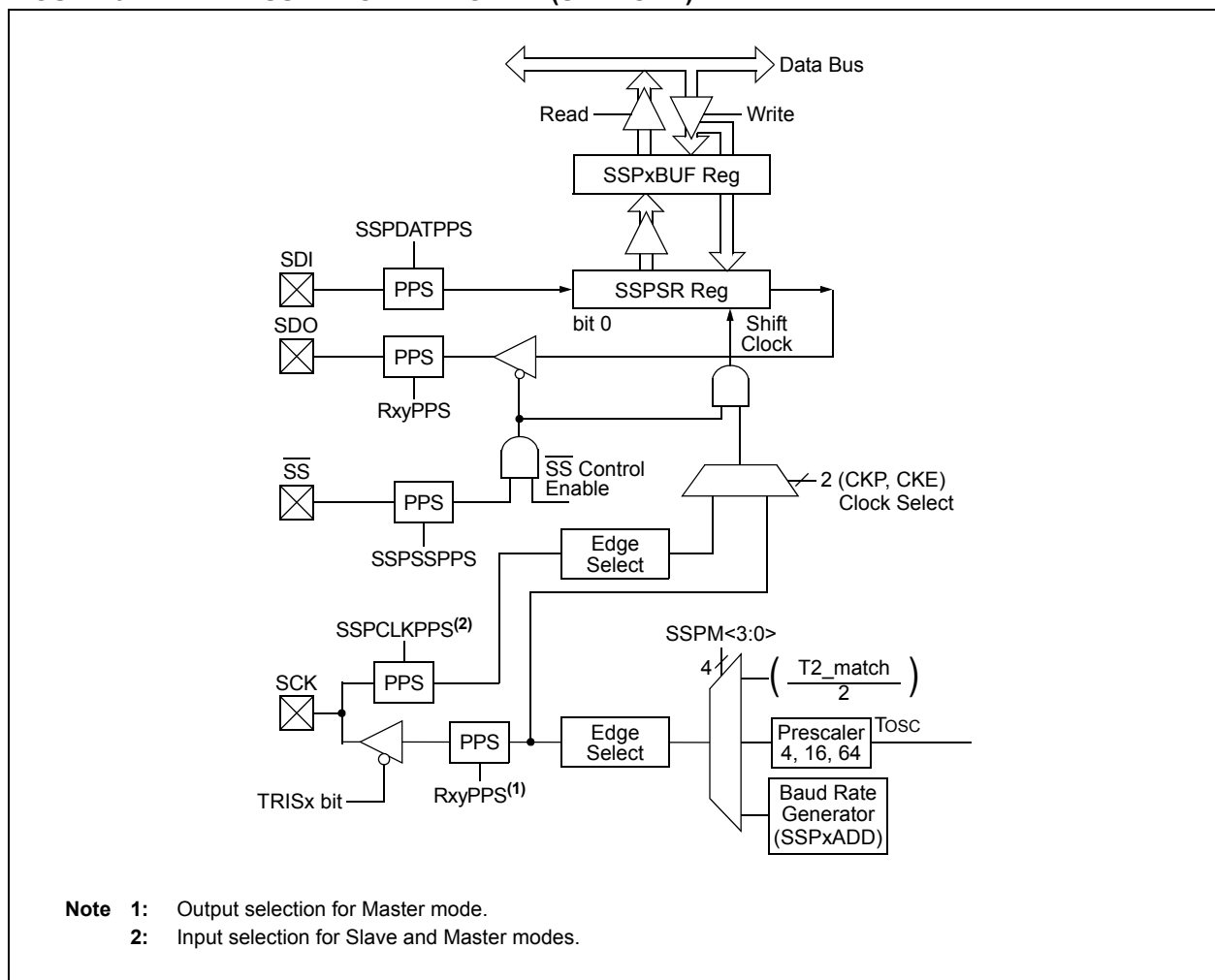
- Serial Peripheral Interface (SPI)
- Inter-Integrated Circuit (I<sup>2</sup>C)

The SPI interface supports the following modes and features:

- Master mode
- Slave mode
- Clock Parity
- Slave Select Synchronization (Slave mode only)
- Daisy-Chain Connection of Slave Devices

Figure 32-1 is a block diagram of the SPI interface module.

**FIGURE 32-1: MSSP BLOCK DIAGRAM (SPI MODE)**

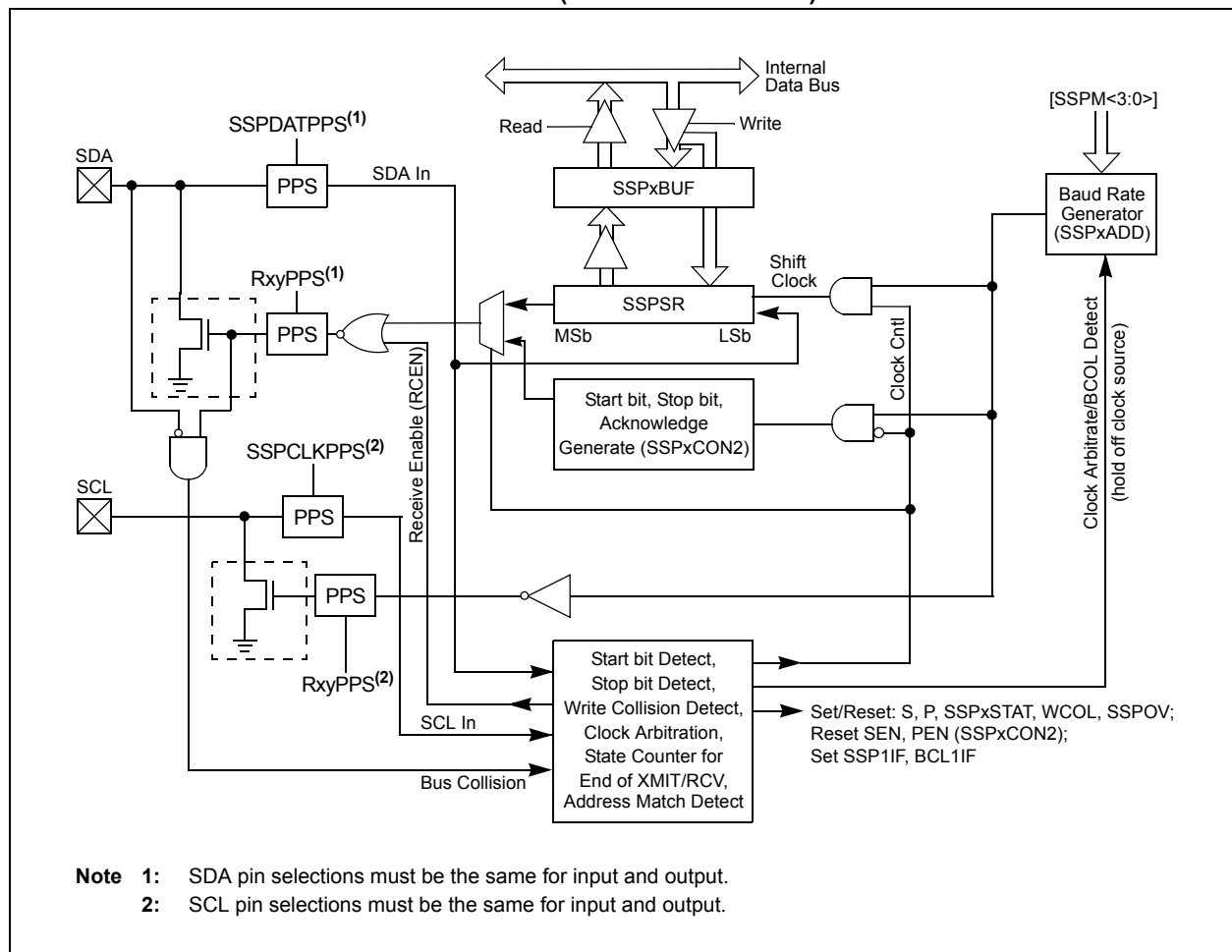


The I<sup>2</sup>C interface supports the following modes and features:

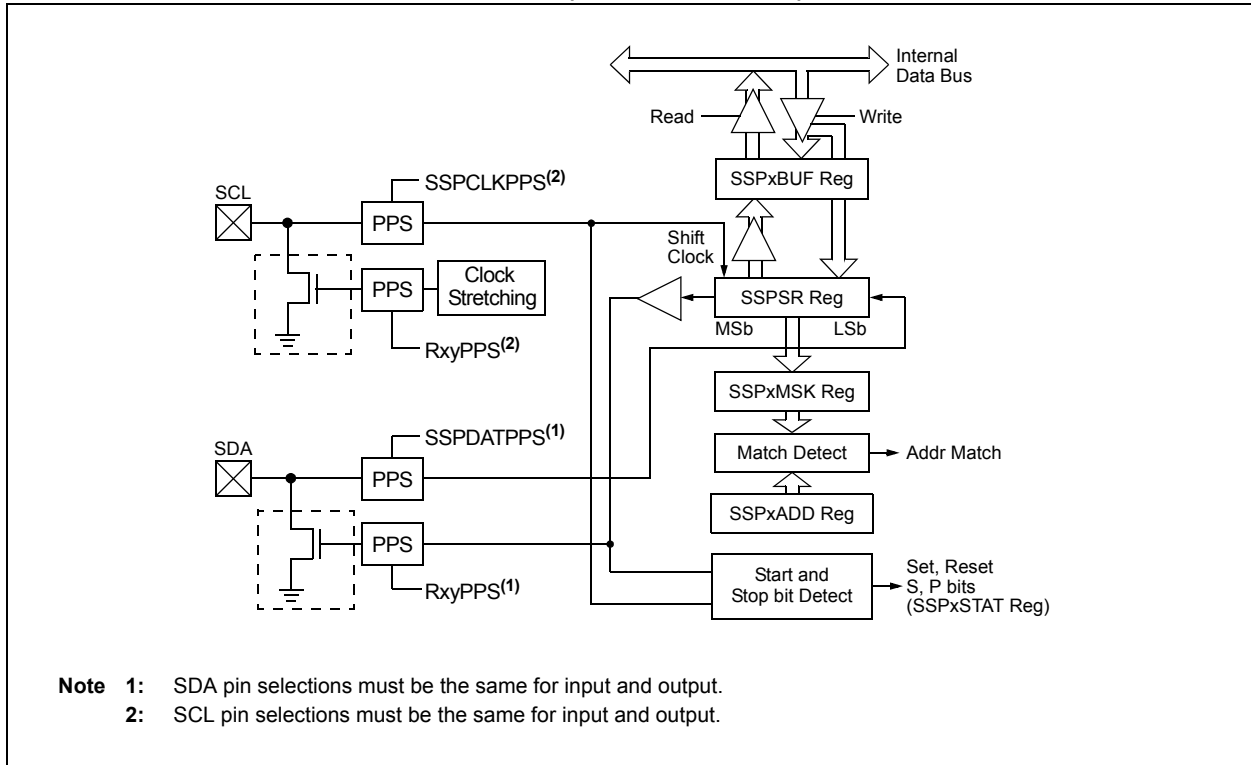
- Master mode
- Slave mode
- Byte NACKing (Slave mode)
- Limited multi-master support
- 7-Bit and 10-Bit Addressing
- Start and Stop interrupts
- Interrupt masking
- Clock stretching
- Bus collision detection
- General call address matching
- Address masking
- Address Hold and Data Hold modes
- Selectable SDA hold times

Figure 32-2 is a block diagram of the I<sup>2</sup>C interface module in Master mode. Figure 32-3 is a diagram of the I<sup>2</sup>C interface module in Slave mode.

**FIGURE 32-2: MSSP BLOCK DIAGRAM (I<sup>2</sup>C MASTER MODE)**



**FIGURE 32-3: MSSP BLOCK DIAGRAM (I<sup>2</sup>C SLAVE MODE)**



## 32.2 SPI Mode Overview

The Serial Peripheral Interface (SPI) bus is a synchronous serial data communication bus that operates in Full-Duplex mode. Devices communicate in a master/slave environment where the master device initiates the communication. A slave device is controlled through a chip select known as Slave Select.

The SPI bus specifies four signal connections:

- Serial Clock (SCK)
- Serial Data Out (SDO)
- Serial Data In (SDI)
- Slave Select ( $\overline{SS}$ )

Figure 32-1 shows the block diagram of the MSSP module when operating in SPI mode.

The SPI bus operates with a single master device and one or more slave devices. When multiple slave devices are used, an independent Slave Select connection is required from the master device to each slave device.

Figure 32-4 shows a typical connection between a master device and multiple slave devices.

The master selects only one slave at a time. Most slave devices have tri-state outputs so their output signal appears disconnected from the bus when they are not selected.

Transmissions involve two shift registers, eight bits in size, one in the master and one in the slave. With either the master or the slave device, data is always shifted out one bit at a time, with the Most Significant bit (MSb) shifted out first. At the same time, a new Least Significant bit (LSb) is shifted into the same register.

Figure 32-5 shows a typical connection between two processors configured as master and slave devices.

Data is shifted out of both shift registers on the programmed clock edge and latched on the opposite edge of the clock.

The master device transmits information out on its SDO output pin, which is connected to, and received by, the slave's SDI input pin. The slave device transmits information out on its SDO output pin, which is connected to, and received by, the master's SDI input pin.

To begin communication, the master device first sends out the clock signal. Both the master and the slave devices should be configured for the same clock polarity.

The master device starts a transmission by sending out the MSb from its shift register. The slave device reads this bit from that same line and saves it into the LSb position of its shift register.

During each SPI clock cycle, a full-duplex data transmission occurs. This means that while the master device is sending out the MSb from its shift register (on its SDO pin), and the slave device is reading this bit and saving it as the LSb of its shift register, that the slave device is also sending out the MSb from its shift register (on its SDO pin) and the master device is reading this bit and saving it as the LSb of its shift register.

After eight bits have been shifted out, the master and slave have exchanged register values.

If there is more data to exchange, the shift registers are loaded with new data and the process repeats itself.

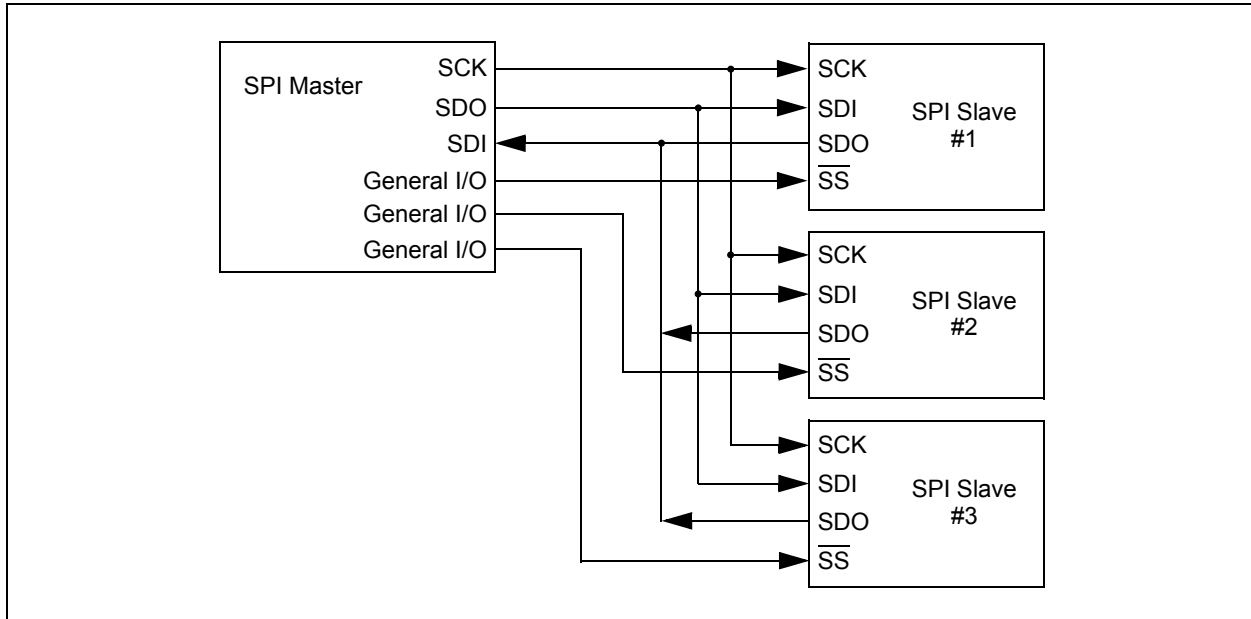
Whether the data is meaningful or not (dummy data), depends on the application software. This leads to three scenarios for data transmission:

- Master sends useful data and slave sends dummy data.
- Master sends useful data and slave sends useful data.
- Master sends dummy data and slave sends useful data.

Transmissions may involve any number of clock cycles. When there is no more data to be transmitted, the master stops sending the clock signal and it deselects the slave.

Every slave device connected to the bus that has not been selected through its Slave Select line must disregard the clock and transmission signals and must not transmit out any data of its own.

**FIGURE 32-4: SPI MASTER AND MULTIPLE SLAVE CONNECTION**



## 32.2.1 SPI MODE REGISTERS

The MSSP module has five registers for SPI mode operation. These are:

- MSSP Status Register (SSPxSTAT)
- MSSP Control Register 1 (SSPxCON1)
- MSSP Control Register 3 (SSPxCON3)
- MSSP Data Buffer Register (SSPxBUF)
- MSSP Address Register (SSPxADD)
- MSSP Shift Register (SSPSR)  
(Not directly accessible)

SSPxCON1 and SSPxSTAT are the control and STATUS registers in SPI mode operation. The SSPxCON1 register is readable and writable. The lower six bits of the SSPxSTAT are read-only. The upper two bits of the SSPxSTAT are read/write.

In one SPI Master mode, SSPxADD can be loaded with a value used in the Baud Rate Generator. More information on the Baud Rate Generator is available in [Section 32.7 “Baud Rate Generator”](#).

SSPSR is the shift register used for shifting data in and out. SSPxBUF provides indirect access to the SSPSR register. SSPxBUF is the buffer register to which data bytes are written, and from which data bytes are read.

In receive operations, SSPSR and SSPxBUF together create a buffered receiver. When SSPSR receives a complete byte, it is transferred to SSPxBUF and the SSPxIF interrupt is set.

During transmission, the SSPxBUF is not buffered. A write to SSPxBUF will write to both SSPxBUF and SSPSR.

## 32.2.2 SPI MODE OPERATION

When initializing the SPI, several options need to be specified. This is done by programming the appropriate control bits (SSPxCON1<5:0> and SSPxSTAT<7:6>). These control bits allow the following to be specified:

- Master mode (SCK is the clock output)
- Slave mode (SCK is the clock input)
- Clock Polarity (Idle state of SCK)
- Data Input Sample Phase (middle or end of data output time)
- Clock Edge (output data on rising/falling edge of SCK)
- Clock Rate (Master mode only)
- Slave Select mode (Slave mode only)

To enable the serial port, SSP Enable bit, SSPEN of the SSPxCON1 register, must be set. To reset or reconfigure SPI mode, clear the SSPEN bit, re-initialize the SSPxCONx registers and then set the SSPEN bit. This configures the SDI, SDO, SCK and  $\overline{SS}$  pins as serial port pins. For the pins to behave as the serial port function, some must have their data direction bits (in the TRISx register) appropriately programmed as follows:

- SDI must have corresponding TRISx bit set
- SDO must have corresponding TRISx bit cleared
- SCK (Master mode) must have corresponding TRISx bit cleared
- SCK (Slave mode) must have corresponding TRISx bit set
- $\overline{SS}$  must have corresponding TRISx bit set

Any serial port function that is not desired may be overridden by programming the corresponding Data Direction (TRISx) register to the opposite value.

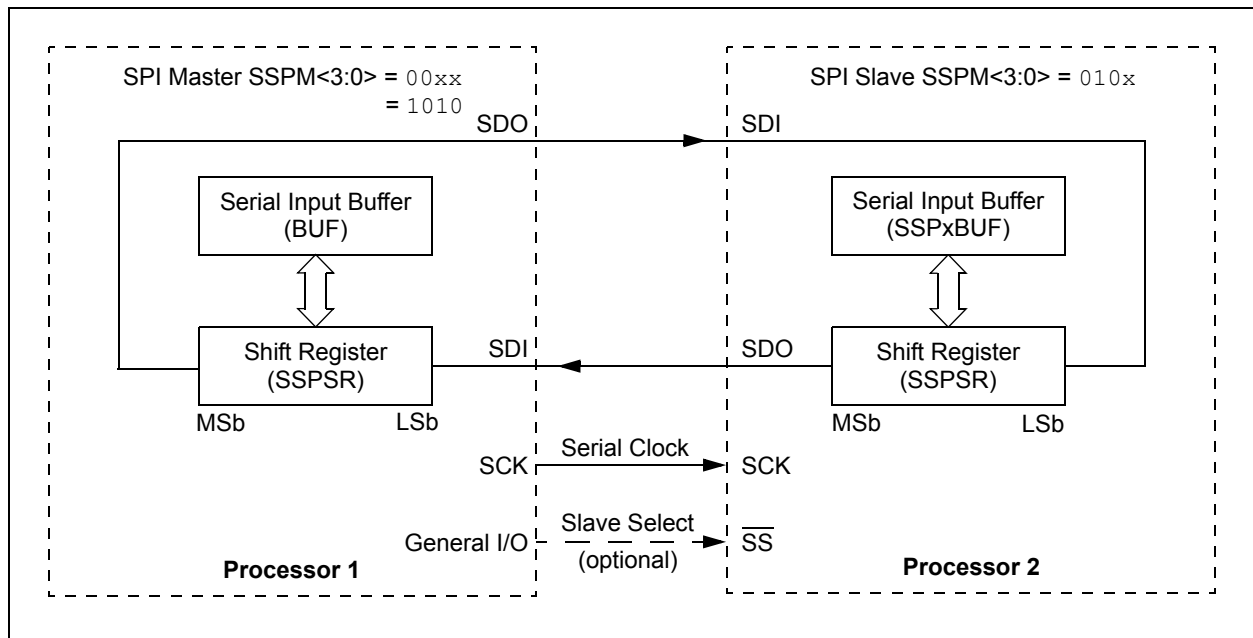


The MSSP consists of a transmit/receive shift register (SSPSR) and a buffer register (SSPxBUF). The SSPSR shifts the data in and out of the device, MSb first. The SSPxBUF holds the data that was written to the SSPSR until the received data is ready. Once the eight bits of data have been received, that byte is moved to the SSPxBUF register. Then, the Buffer Full Detect bit, BF of the SSPxSTAT register, and the interrupt flag bit, SSPxIF, are set. This double-buffering of the received data (SSPxBUF) allows the next byte to start reception before reading the data that was just received. Any write to the SSPxBUF register during transmission/reception of data will be ignored and the Write Collision Detect bit, WCOL of the SSPxCON1 register, will be set. User software must clear the WCOL bit to allow the following write(s) to the SSPxBUF register to complete successfully.

When the application software is expecting to receive valid data, the SSPxBUF should be read before the next byte of data to transfer is written to the SSPxBUF. The Buffer Full bit, BF of the SSPxSTAT register, indicates when SSPxBUF has been loaded with the received data (transmission is complete). When the SSPxBUF is read, the BF bit is cleared. This data may be irrelevant if the SPI is only a transmitter. Generally, the MSSP interrupt is used to determine when the transmission/reception has completed. If the interrupt method is not going to be used, then software polling can be done to ensure that a write collision does not occur.

The SSPSR is not directly readable or writable and can only be accessed by addressing the SSPxBUF register. Additionally, the SSPxSTAT register indicates the various Status conditions.

**FIGURE 32-5: SPI MASTER/SLAVE CONNECTION**



## 32.2.3 SPI MASTER MODE

The master can initiate the data transfer at any time because it controls the SCK line. The master determines when the slave (Processor 2, [Figure 32-5](#)) is to broadcast data by the software protocol.

In Master mode, the data is transmitted/received as soon as the SSPxBUF register is written to. If the SPI is only going to receive, the SDO output could be disabled (programmed as an input). The SSPSR register will continue to shift in the signal present on the SDI pin at the programmed clock rate. As each byte is received, it will be loaded into the SSPxBUF register as if a normal received byte (interrupts and status bits appropriately set).

The clock polarity is selected by appropriately programming the CKP bit of the SSPxCON1 register and the CKE bit of the SSPxSTAT register. This then, would give waveforms for SPI communication as shown in [Figure 32-6](#), [Figure 32-8](#), [Figure 32-9](#) and [Figure 32-10](#), where the MSB is transmitted first. In Master mode, the SPI clock rate (bit rate) is user programmable to be one of the following:

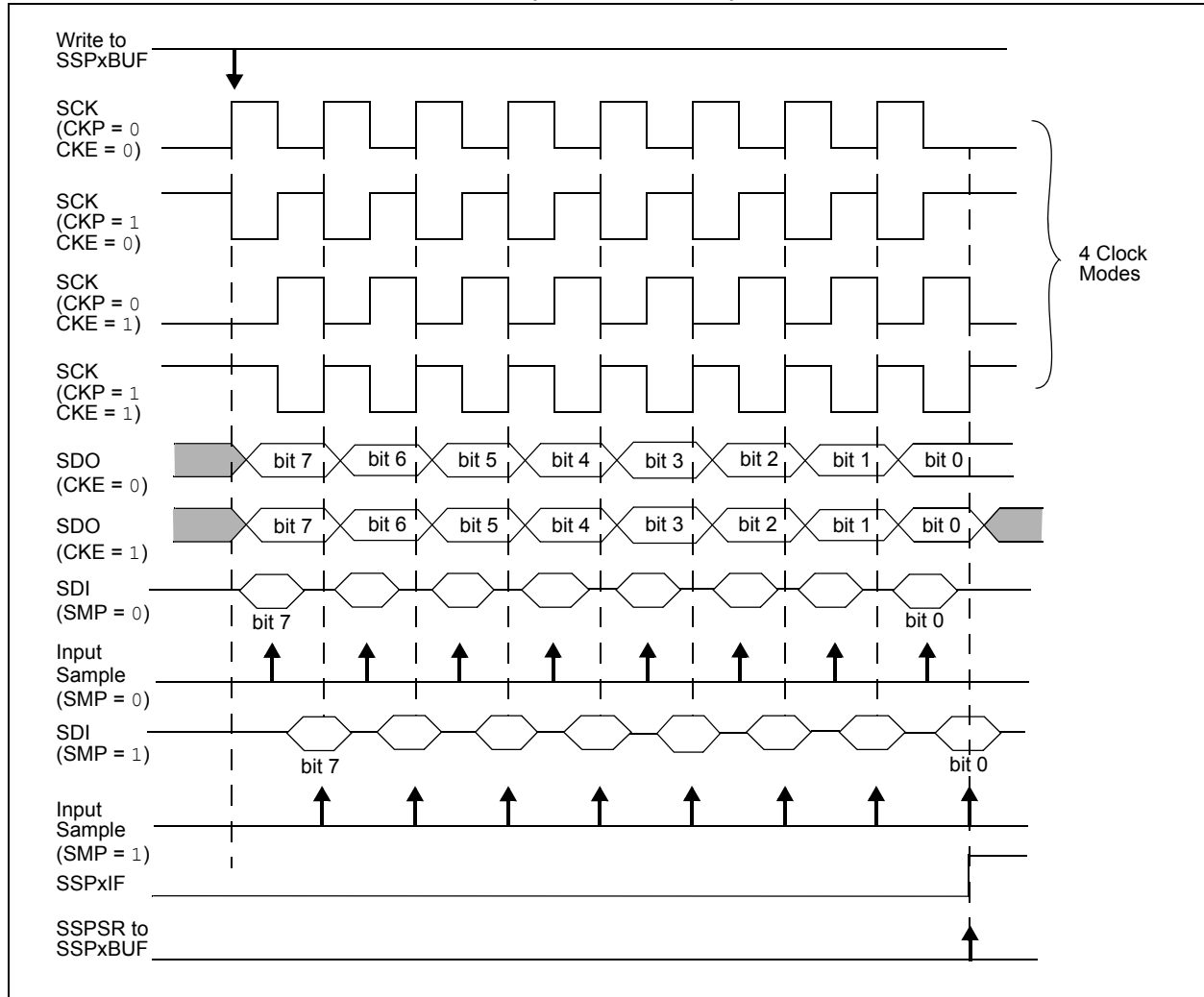
- $F_{osc}/4$  (or  $T_{CY}$ )
- $F_{osc}/16$  (or  $4 * T_{CY}$ )
- $F_{osc}/64$  (or  $16 * T_{CY}$ )
- Timer2 output/2
- $F_{osc}/(4 * (SSPxADD + 1))$

[Figure 32-6](#) shows the waveforms for Master mode.

When the CKE bit is set, the SDO data is valid before there is a clock edge on SCK. The change of the input sample is shown based on the state of the SMP bit. The time when the SSPxBUF is loaded with the received data is shown.

<p><b>Note:</b> In Master mode, the clock signal output to the SCK pin is also the clock signal input to the peripheral. The pin selected for output with the RxyPPS register must also be selected as the peripheral input with the SSPCLKPPS register.</p>
--

**FIGURE 32-6: SPI MODE WAVEFORM (MASTER MODE)**



## 32.2.4 SPI SLAVE MODE

In Slave mode, the data is transmitted and received as external clock pulses appear on SCK. When the last bit is latched, the SSPxIF interrupt flag bit is set.

Before enabling the module in SPI Slave mode, the clock line must match the proper Idle state. The clock line can be observed by reading the SCK pin. The Idle state is determined by the CKP bit of the SSPxCON1 register.

While in Slave mode, the external clock is supplied by the external clock source on the SCK pin. This external clock must meet the minimum high and low times as specified in the electrical specifications.

While in Sleep mode, the slave can transmit/receive data. The shift register is clocked from the SCK pin input and when a byte is received, the device will generate an interrupt. If enabled, the device will wake-up from Sleep.

### 32.2.4.1 Daisy-Chain Configuration

The SPI bus can sometimes be connected in a daisy-chain configuration. The first slave output is connected to the second slave input, the second slave output is connected to the third slave input, and so on. The final slave output is connected to the master input. Each slave sends out, during a second group of clock pulses, an exact copy of what was received during the first group of clock pulses. The whole chain acts as one large communication shift register. The daisy-chain feature only requires a single Slave Select line from the master device.

Figure 32-7 shows the block diagram of a typical daisy-chain connection when operating in SPI mode.

In a daisy-chain configuration, only the most recent byte on the bus is required by the slave. Setting the BOEN bit of the SSPxCON3 register will enable writes to the SSPxBUF register, even if the previous byte has not been read. This allows the software to ignore data that may not apply to it.

## 32.2.5 SLAVE SELECT SYNCHRONIZATION

The Slave Select can also be used to synchronize communication. The Slave Select line is held high until the master device is ready to communicate. When the Slave Select line is pulled low, the slave knows that a new transmission is starting.

If the slave fails to receive the communication properly, it will be reset at the end of the transmission, when the Slave Select line returns to a high state. The slave is then ready to receive a new transmission when the Slave Select line is pulled low again. If the Slave Select line is not used, there is a risk that the slave will eventually become out of sync with the master. If the slave misses a bit, it will always be one bit off in future transmissions. Use of the Slave Select line allows the slave and master to align themselves at the beginning of each transmission.

The  $\overline{SS}$  pin allows a Synchronous Slave mode. The SPI must be in Slave mode with  $\overline{SS}$  pin control enabled ( $SSPxCON1<3:0> = 0100$ ).

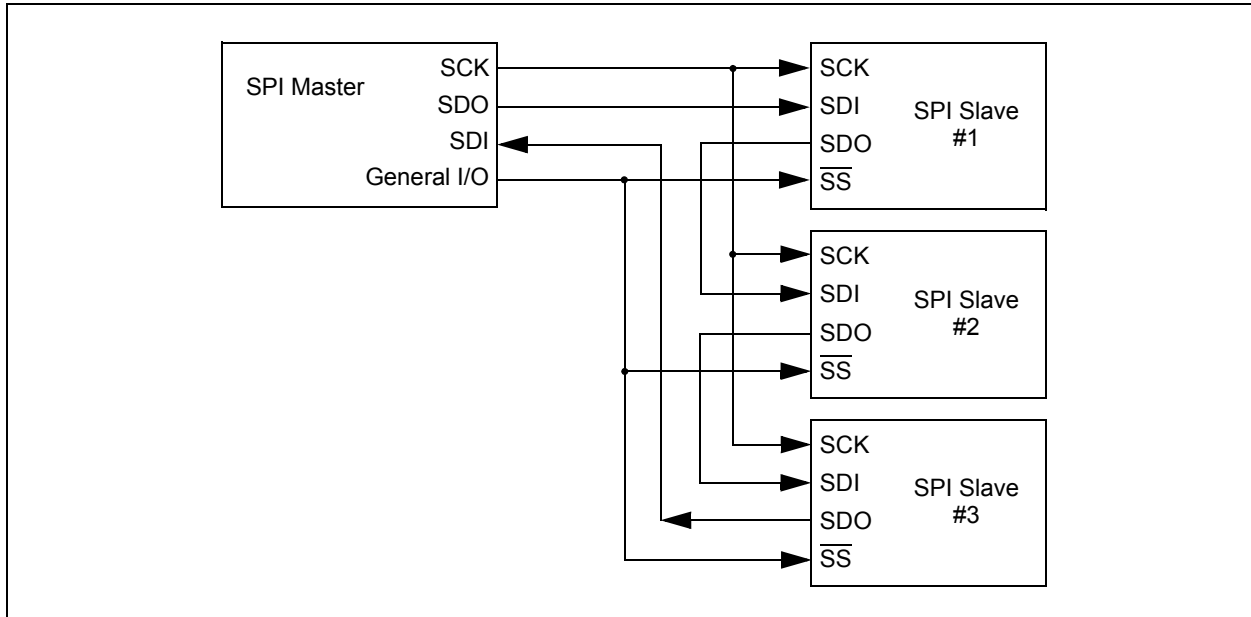
When the  $\overline{SS}$  pin is low, transmission and reception are enabled and the SDO pin is driven.

When the  $\overline{SS}$  pin goes high, the SDO pin is no longer driven, even if in the middle of a transmitted byte and becomes a floating output. External pull-up/pull-down resistors may be desirable depending on the application.

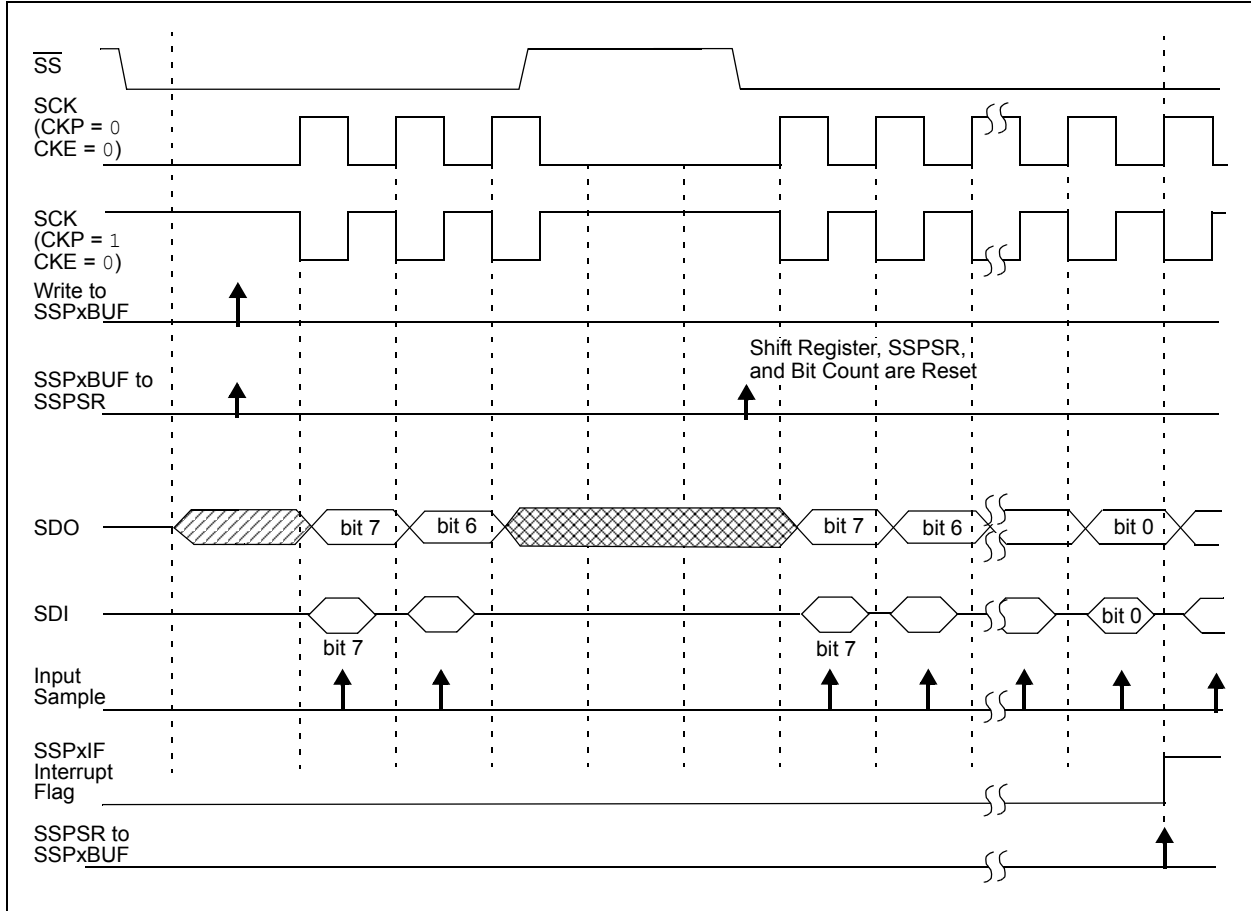
- Note 1:** When the SPI is in Slave mode with  $\overline{SS}$  pin control enabled ( $SSPxCON1<3:0> = 0100$ ), the SPI module will reset if the  $\overline{SS}$  pin is set to VDD.
- 2:** When the SPI is used in Slave mode with CKE set; the user must enable  $\overline{SS}$  pin control.
- 3:** While operating in SPI Slave mode, the SMP bit of the SSPxSTAT register must remain clear.

When the SPI module resets, the bit counter is forced to '0'. This can be done by either forcing the  $\overline{SS}$  pin to a high level or clearing the SSPEN bit.

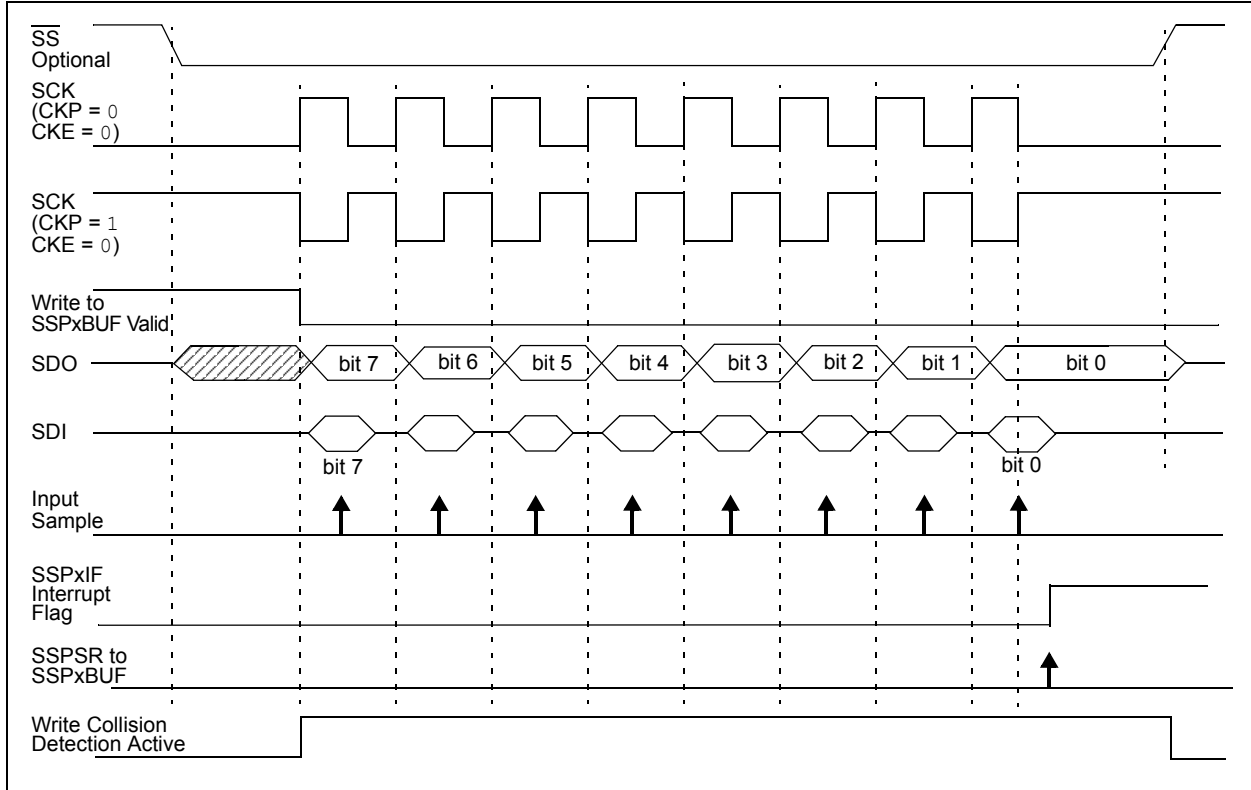
**FIGURE 32-7: SPI DAISY-CHAIN CONNECTION**



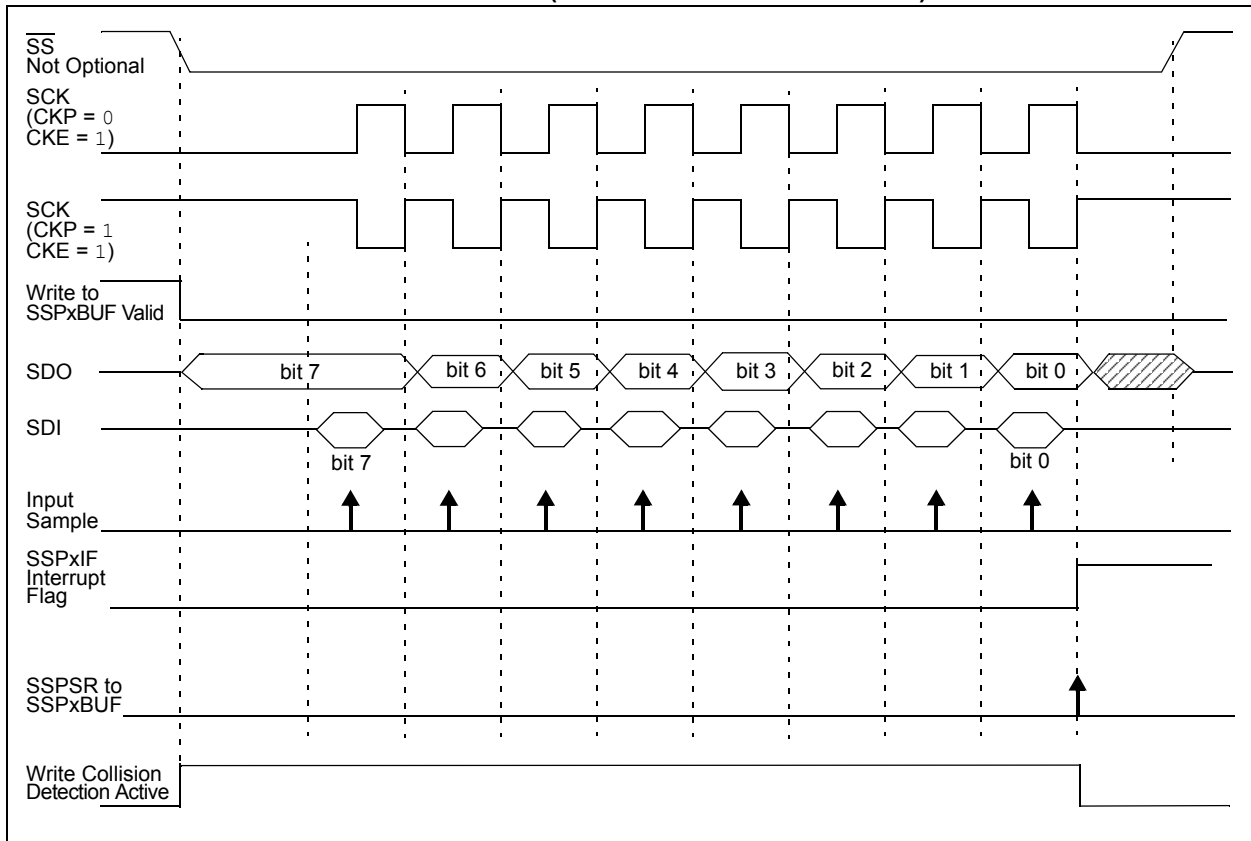
**FIGURE 32-8: SLAVE SELECT SYNCHRONOUS WAVEFORM**



**FIGURE 32-9: SPI MODE WAVEFORM (SLAVE MODE WITH CKE = 0)**



**FIGURE 32-10: SPI MODE WAVEFORM (SLAVE MODE WITH CKE = 1)**



# PIC16(L)F1764/5/8/9

## 32.2.6 SPI OPERATION IN SLEEP MODE

In SPI Master mode, module clocks may be operating at a different speed than when in Full-Power mode; in the case of the Sleep mode, all clocks are halted.

Special care must be taken by the user when the MSSP clock is much faster than the system clock.

In Slave mode, when MSSP interrupts are enabled, after the master completes sending data, an MSSP interrupt will wake the controller from Sleep.

If an exit from Sleep mode is not desired, MSSP interrupts should be disabled.

In SPI Master mode, when the Sleep mode is selected, all module clocks are halted and the transmission/reception will remain in that state until the device wakes. After the device returns to Run mode, the module will resume transmitting and receiving data.

In SPI Slave mode, the SPI Transmit/Receive Shift register operates asynchronously to the device. This allows the device to be placed in Sleep mode and data to be shifted into the SPI Transmit/Receive Shift register. When all eight bits have been received, the MSSP interrupt flag bit will be set and if enabled, will wake the device.

**TABLE 32-1: SUMMARY OF REGISTERS ASSOCIATED WITH SPI OPERATION**

Name	Bit 7	Bit 6	Bit 5	Bit 4	Bit 3	Bit 2	Bit 1	Bit 0	Register on Page
ANSELA	—	—	—	ANSA4	—	ANSA<2:0>			139
ANSELC	ANSC<7:6> <sup>(2)</sup>		—	—	ANSC<3:0>				150
INTCON	GIE	PEIE	TMR0IE	INTE	IOCFIF	TMR0IF	INTF	IOCFIF	101
PIE1	TMR1GIE	ADIE	RCIE	TXIE	SSP1IE	CCP1IE	TMR2IE	TMR1IE	102
PIR1	TMR1GIF	ADIF	RCIF	TXIF	SSP1IF	CCP1IF	TMR2IF	TMR1IF	106
RxyPPS	—	—	—	RxyPPS<4:0>				156	
SSPCLKPPS	—	—	—	SSPCLKPPS<4:0>				156, 158	
SSPDATPPS	—	—	—	SSPDATPPS<4:0>				156, 158	
SSPSSPPS	—	—	—	SSPSSPPS<4:0>				156, 158	
SSP1BUF	Synchronous Serial Port Receive Buffer/Transmit Register								384*
SSP1CON1	WCOL	SSPOV	SSPEN	CKP	SSPM<3:0>				430
SSP1CON3	ACKTIM	PCIE	SCIE	BOEN	SDAHT	SBCDE	AHEN	DHEN	428
SSP1STAT	SMP	CKE	D/Ā	P	S	R/W	UA	BF	428
TRISA	—	—	TRISA<5:4>		— <sup>(1)</sup>	TRISA<2:0>			138
TRISB <sup>(2)</sup>	TRISB<7:4>				—	—	—	—	144
TRISC	TRISC<7:6> <sup>(2)</sup>		TRISC<5:0>						149

**Legend:** — = unimplemented location, read as '0'. Shaded cells are not used by the MSSP in SPI mode.

\* Page provides register information.

**Note 1:** Unimplemented, read as '1'.

**Note 2:** PIC16(L)F1768/9 only.

## 32.3 I<sup>2</sup>C MODE OVERVIEW

The Inter-Integrated Circuit (I<sup>2</sup>C) bus is a multi-master serial data communication bus. Devices communicate in a master/slave environment where the master devices initiate the communication. A slave device is controlled through addressing.

The I<sup>2</sup>C bus specifies two signal connections:

- Serial Clock (SCL)
- Serial Data (SDA)

Figure 32-11 shows the block diagram of the MSSP module when operating in I<sup>2</sup>C mode.

Both the SCL and SDA connections are bidirectional open-drain lines, each requiring pull-up resistors for the supply voltage. Pulling the line to ground is considered a logical zero and letting the line float is considered a logical one.

Figure 32-11 shows a typical connection between two processors configured as master and slave devices.

The I<sup>2</sup>C bus can operate with one or more master devices and one or more slave devices.

There are four potential modes of operation for a given device:

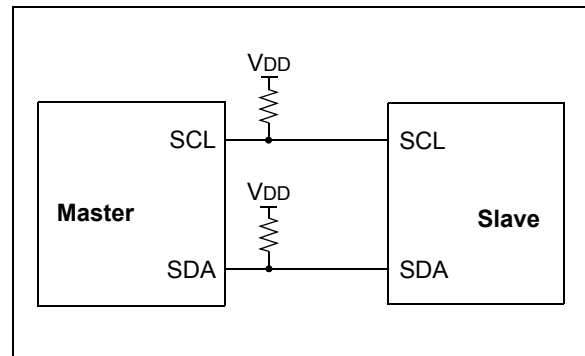
- Master Transmit mode  
(master is transmitting data to a slave)
- Master Receive mode  
(master is receiving data from a slave)
- Slave Transmit mode  
(slave is transmitting data to a master)
- Slave Receive mode  
(slave is receiving data from the master)

To begin communication, a master device starts out in Master Transmit mode. The master device sends out a Start bit, followed by the address byte of the slave it intends to communicate with. This is followed by a single read/write bit, which determines whether the master intends to transmit to or receive data from the slave device.

If the requested slave exists on the bus, it will respond with an Acknowledge bit, otherwise known as an ACK. The master then continues in either Transmit mode or Receive mode and the slave continues in the complement, either in Receive mode or Transmit mode, respectively.

A Start bit is indicated by a high-to-low transition of the SDA line while the SCL line is held high. Address and data bytes are sent out, Most Significant bit (MSb) first. The read/write bit is sent out as a logical one when the master intends to read data from the slave and is sent out as a logical zero when it intends to write data to the slave.

FIGURE 32-11: I<sup>2</sup>C MASTER/SLAVE CONNECTION



The Acknowledge bit ( $\overline{\text{ACK}}$ ) is an active-low signal, which holds the SDA line low to indicate to the transmitter that the slave device has received the transmitted data and is ready to receive more.

The transition of a data bit is always performed while the SCL line is held low. Transitions that occur while the SCL line is held high are used to indicate Start and Stop bits.

If the master intends to write to the slave, then it repeatedly sends out a byte of data, with the slave responding after each byte with an  $\overline{\text{ACK}}$  bit. In this example, the master device is in Master Transmit mode and the slave is in Slave Receive mode.

If the master intends to read from the slave, then it repeatedly receives a byte of data from the slave and responds after each byte with an  $\overline{\text{ACK}}$  bit. In this example, the master device is in Master Receive mode and the slave is Slave Transmit mode.

On the last byte of data communicated, the master device may end the transmission by sending a Stop bit. If the master device is in Receive mode, it sends the Stop bit in place of the last ACK bit. A Stop bit is indicated by a low-to-high transition of the SDA line while the SCL line is held high.

In some cases, the master may want to maintain control of the bus and re-initiate another transmission. If so, the master device may send another Start bit in place of the Stop bit or last ACK bit when it is in receive mode.

The I<sup>2</sup>C bus specifies three message protocols;

- Single message where a master writes data to a slave.
- Single message where a master reads data from a slave.
- Combined message where a master initiates a minimum of two writes, or two reads, or a combination of writes and reads, to one or more slaves.



When one device is transmitting a logical one, or letting the line float, and a second device is transmitting a logical zero, or holding the line low, the first device can detect that the line is not a logical one. This detection, when used on the SCL line, is called clock stretching. Clock stretching gives slave devices a mechanism to control the flow of data. When this detection is used on the SDA line, it is called arbitration. Arbitration ensures that there is only one master device communicating at any single time.

### 32.3.1 CLOCK STRETCHING

When a slave device has not completed processing data, it can delay the transfer of more data through the process of clock stretching. An addressed slave device may hold the SCL clock line low after receiving or sending a bit, indicating that it is not yet ready to continue. The master that is communicating with the slave will attempt to raise the SCL line in order to transfer the next bit, but will detect that the clock line has not yet been released. Because the SCL connection is open-drain, the slave has the ability to hold that line low until it is ready to continue communicating.

Clock stretching allows receivers that cannot keep up with a transmitter to control the flow of incoming data.

### 32.3.2 ARBITRATION

Each master device must monitor the bus for Start and Stop bits. If the device detects that the bus is busy, it cannot begin a new message until the bus returns to an Idle state.

However, two master devices may try to initiate a transmission on or about the same time. When this occurs, the process of arbitration begins. Each transmitter checks the level of the SDA data line and compares it to the level that it expects to find. The first transmitter to observe that the two levels do not match, loses arbitration and must stop transmitting on the SDA line.

For example, if one transmitter holds the SDA line to a logical one (lets it float) and a second transmitter holds it to a logical zero (pulls it low), the result is that the SDA line will be low. The first transmitter then observes that the level of the line is different than expected and concludes that another transmitter is communicating.

The first transmitter to notice this difference is the one that loses arbitration and must stop driving the SDA line. If this transmitter is also a master device, it also must stop driving the SCL line. It then can monitor the lines for a Stop condition before trying to re-issue its transmission. In the meantime, the other device that has not noticed any difference between the expected and actual levels on the SDA line continues with its original transmission. It can do so without any complications, because so far, the transmission appears exactly as expected with no other transmitter disturbing the message.

Slave Transmit mode can also be arbitrated, when a master addresses multiple slaves, but this is less common.

If two master devices are sending a message to two different slave devices at the address stage, the master sending the lower slave address always wins arbitration. When two master devices send messages to the same slave address, and addresses can sometimes refer to multiple slaves, the arbitration process must continue into the data stage.

Arbitration usually occurs very rarely, but it is a necessary process for proper multi-master support.

## 32.4 I<sup>2</sup>C MODE OPERATION

All MSSP I<sup>2</sup>C communication is byte-oriented and shifted out, MSb first. Six SFR registers and two interrupt flags interface the module with the PIC<sup>®</sup> microcontroller and user software. Two pins, SDA and SCL, are exercised by the module to communicate with other external I<sup>2</sup>C devices.

### 32.4.1 BYTE FORMAT

All communication in I<sup>2</sup>C is done in 9-bit segments. A byte is sent from a master to a slave or vice-versa, followed by an Acknowledge bit sent back. After the eighth falling edge of the SCL line, the device outputting data on the SDA changes that pin to an input and reads in an Acknowledge value on the next clock pulse.

The clock signal, SCL, is provided by the master. Data is valid to change while the SCL signal is low, and sampled on the rising edge of the clock. Changes on the SDA line while the SCL line is high define special conditions on the bus, explained below.

### 32.4.2 DEFINITION OF I<sup>2</sup>C TERMINOLOGY

There is language and terminology in the description of I<sup>2</sup>C communication that have definitions specific to I<sup>2</sup>C. That word usage is defined below and may be used in the rest of this document without explanation. This table was adapted from the Philips<sup>®</sup> I<sup>2</sup>C specification.

### 32.4.3 SDA AND SCL PINS

Selection of any I<sup>2</sup>C mode with the SSPEN bit set, forces the SCL and SDA pins to be open-drain. These pins should be set by the user to inputs by setting the appropriate TRISx bits.

**Note 1:** Data is tied to output zero when an I<sup>2</sup>C mode is enabled.

**2:** Any device pin can be selected for SDA and SCL functions with the PPS peripheral. These functions are bidirectional. The SDA input is selected with the SSPDATPPS registers. The SCL input is selected with the SSPCLKPPS registers. Outputs are selected with the RxyPPS registers. It is the user's responsibility to make the selections so that both the input and the output for each function is on the same pin.

### 32.4.4 SDA HOLD TIME

The hold time of the SDA pin is selected by the SDAHT bit of the SSPxCON3 register. Hold time is the time SDA is held valid after the falling edge of SCL. Setting the SDAHT bit selects a longer 300 ns minimum hold time and may help on buses with large capacitance.

TABLE 32-2: I<sup>2</sup>C BUS TERMS

TERM	Description
Transmitter	The device which shifts data out onto the bus.
Receiver	The device which shifts data in from the bus.
Master	The device that initiates a transfer, generates clock signals and terminates a transfer.
Slave	The device addressed by the master.
Multi-master	A bus with more than one device that can initiate data transfers.
Arbitration	Procedure to ensure that only one master at a time controls the bus. Winning arbitration ensures that the message is not corrupted.
Synchronization	Procedure to synchronize the clocks of two or more devices on the bus.
Idle	No master is controlling the bus, and both SDA and SCL lines are high.
Active	Any time one or more master devices is controlling the bus.
Addressed Slave	Slave device that has received a matching address and is actively being clocked by a master.
Matching Address	Address byte that is clocked into a slave that matches the value stored in SSPxADD.
Write Request	Slave receives a matching address with R/W bit clear and is ready to clock in data.
Read Request	Master sends an address byte with the R/W bit set, indicating that it wishes to clock data out of the slave. This data is the next and all following bytes until a Restart or Stop.
Clock Stretching	When a device on the bus hold SCL low to stall communication.
Bus Collision	Any time the SDA line is sampled low by the module while it is outputting and expected high state.

## 32.4.5 START CONDITION

The I<sup>2</sup>C specification defines a Start condition as a transition of SDA from a high to a low state while the SCL line is high. A Start condition is always generated by the master and signifies the transition of the bus from an Idle to an active state. Figure 32-12 shows wave forms for Start and Stop conditions.

A bus collision can occur on a Start condition if the module samples the SDA line low before asserting it low. This does not conform to the I<sup>2</sup>C specification that states no bus collision can occur on a Start.

## 32.4.6 STOP CONDITION

A Stop condition is a transition of the SDA line from low-to-high state while the SCL line is high.

**Note:** At least one SCL low time must appear before a Stop is valid, therefore, if the SDA line goes low, then high again while the SCL line stays high, only the Start condition is detected.

## 32.4.7 RESTART CONDITION

A Restart is valid any time that a Stop would be valid. A master can issue a Restart if it wishes to hold the bus after terminating the current transfer. A Restart has the same effect on the slave that a Start would, resetting all slave logic and preparing it to clock in an address. The master may want to address the same or another slave. Figure 32-13 shows the wave form for a Restart condition.

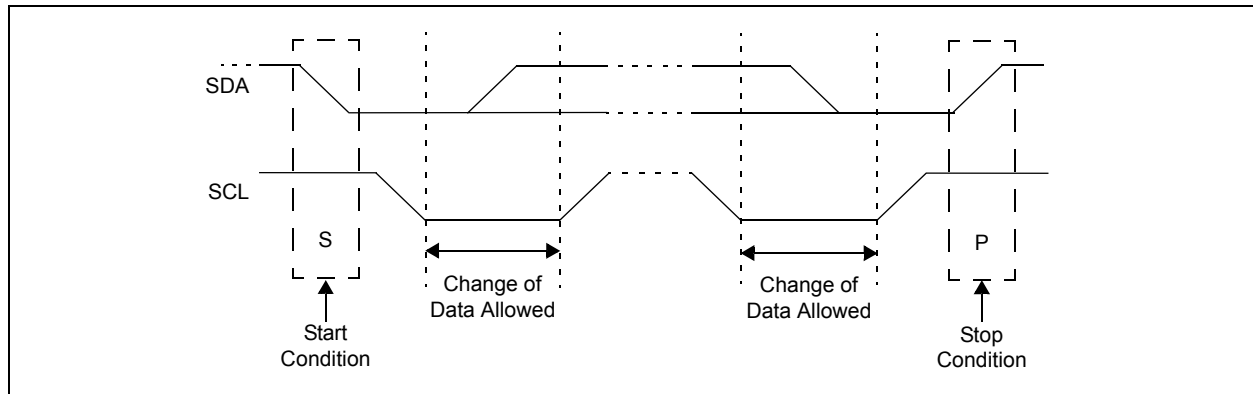
In 10-Bit Addressing Slave mode, a Restart is required for the master to clock data out of the addressed slave. Once a slave has been fully addressed, matching both high and low address bytes, the master can issue a Restart and the high address byte with the R/W bit set. The slave logic will then hold the clock and prepare to clock out data.

After a full match with R/W clear in 10-bit mode, a prior match flag is set and maintained until a Stop condition, a high address with R/W clear or high address match fails.

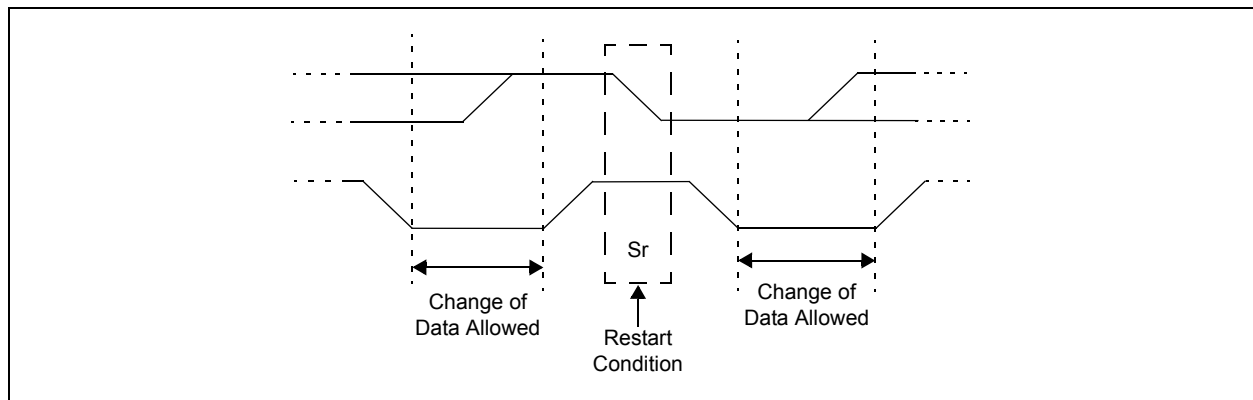
## 32.4.8 START/STOP CONDITION INTERRUPT MASKING

The SCIE and PCIE bits of the SSPxCON3 register can enable the generation of an interrupt in Slave modes that do not typically support this function. In Slave modes where interrupt on Start and Stop detect is already enabled, these bits will have no effect.

**FIGURE 32-12: I<sup>2</sup>C START AND STOP CONDITIONS**



**FIGURE 32-13: I<sup>2</sup>C RESTART CONDITION**



## 32.4.9 ACKNOWLEDGE SEQUENCE

The 9th SCL pulse for any transferred byte in I<sup>2</sup>C is dedicated as an Acknowledge. It allows receiving devices to respond back to the transmitter by pulling the SDA line low. The transmitter must release control of the line during this time to shift in the response. The Acknowledge ( $\overline{\text{ACK}}$ ) is an active-low signal, pulling the SDA line low indicates to the transmitter that the device has received the transmitted data and is ready to receive more.

The result of an  $\overline{\text{ACK}}$  is placed in the ACKSTAT bit of the SSPxCON2 register.

Slave software, when the AHEN and DHEN bits are set, allows the user to set the  $\overline{\text{ACK}}$  value sent back to the transmitter. The ACKDT bit of the SSPxCON2 register is set/cleared to determine the response.

Slave hardware will generate an  $\overline{\text{ACK}}$  response if the AHEN and DHEN bits of the SSPxCON3 register are clear.

There are certain conditions where an  $\overline{\text{ACK}}$  will not be sent by the slave. If the BF bit of the SSPxSTAT register or the SSPOV bit of the SSPxCON1 register are set when a byte is received.

When the module is addressed, after the eighth falling edge of SCL on the bus, the ACKTIM bit of the SSPxCON3 register is set. The ACKTIM bit indicates the Acknowledge time of the active bus. The ACKTIM status bit is only active when the AHEN bit or DHEN bit is enabled.

## 32.5 I<sup>2</sup>C Slave Mode Operation

The MSSP Slave mode operates in one of four modes selected by the SSPM<3:0> bits of SSPxCON1 register. The modes can be divided into 7-Bit and 10-Bit Addressing modes. 10-Bit Addressing mode operates the same as 7-bit with some additional overhead for handling the larger addresses.

Modes with Start and Stop bit interrupts operate the same as the other modes, with SSPxIF additionally getting set upon detection of a Start, Restart or Stop condition.

## 32.5.1 SLAVE MODE ADDRESSES

The SSPxADD register (Register 32-6) contains the Slave mode address. The first byte received after a Start or Restart condition is compared against the value stored in this register. If the byte matches, the value is loaded into the SSPxBUF register and an interrupt is generated. If the value does not match, the module goes Idle and no indication is given to the software that anything happened.

The SSP Mask register (Register 32-5) affects the address matching process. See Section 32.5.8 “SSP Mask Register” for more information.

### 32.5.1.1 I<sup>2</sup>C Slave 7-Bit Addressing Mode

In 7-Bit Addressing mode, the LSb of the received data byte is ignored when determining if there is an address match.

### 32.5.1.2 I<sup>2</sup>C Slave 10-Bit Addressing Mode

In 10-Bit Addressing mode, the first received byte is compared to the binary value of '1 1 1 1 0 A9 A8 0'. A9 and A8 are the two MSbs of the 10-bit address and stored in bits 2 and 1 of the SSPxADD register.

After the Acknowledge of the high byte, the UA bit is set and SCL is held low until the user updates SSPxADD with the low address. The low address byte is clocked in and all eight bits are compared to the low address value in SSPxADD. Even if there is not an address match, SSPxIF and UA are set, and SCL is held low until SSPxADD is updated to receive a high byte again. When SSPxADD is updated, the UA bit is cleared. This ensures the module is ready to receive the high address byte on the next communication.

A high and low address match as a write request is required at the start of all 10-Bit Addressing communication. A transmission can be initiated by issuing a Restart once the slave is addressed, and clocking in the high address with the R/W bit set. The slave hardware will then Acknowledge the read request and prepare to clock out data. This is only valid for a slave after it has received a complete high and low address byte match.

## 32.5.2 SLAVE RECEPTION

When the  $R/\overline{W}$  bit of a matching received address byte is clear, the  $R/\overline{W}$  bit of the SSPxSTAT register is cleared. The received address is loaded into the SSPxBUF register and Acknowledged.

When the overflow condition exists for a received address, then not Acknowledge is given. An overflow condition is defined as either bit, BF of the SSPxSTAT register, is set or bit, SSPOV of the SSPxCON1 register, is set. The BOEN bit of the SSPxCON3 register modifies this operation. For more information see [Register 32-4](#).

An MSSP interrupt is generated for each transferred data byte. Flag bit, SSPxIF, must be cleared by software.

When the SEN bit of the SSPxCON2 register is set, SCL will be held low (clock stretch) following each received byte. The clock must be released by setting the CKP bit of the SSPxCON1 register, except sometimes in 10-bit mode. See [Section 32.5.6.2 “10-Bit Addressing Mode”](#) for more detail.

### 32.5.2.1 7-Bit Addressing Reception

This section describes a standard sequence of events for the MSSP module configured as an I<sup>2</sup>C slave in 7-Bit Addressing mode. [Figure 32-14](#) and [Figure 32-15](#) is used as a visual reference for this description.

This is a step by step process of what typically must be done to accomplish I<sup>2</sup>C communication.

1. Start bit is detected.
2. S bit of SSPxSTAT is set; SSPxIF is set if interrupt on Start detect is enabled.
3. Matching address with  $R/\overline{W}$  bit clear is received.
4. The slave pulls SDA low, sending an  $\overline{ACK}$  to the master and sets the SSPxIF bit.
5. Software clears the SSPxIF bit.
6. Software reads the received address from SSPxBUF, clearing the BF flag.
7. If SEN = 1, slave software sets the CKP bit to release the SCL line.
8. The master clocks out a data byte.
9. Slave drives SDA low, sending an  $\overline{ACK}$  to the master and sets the SSPxIF bit.
10. Software clears SSPxIF.
11. Software reads the received byte from SSPxBUF, clearing BF.
12. Steps 8-12 are repeated for all received bytes from the master.
13. Master sends Stop condition, setting P bit of SSPxSTAT and the bus goes Idle.

### 32.5.2.2 7-Bit Reception with AHEN and DHEN

Slave device reception with AHEN and DHEN set operates the same as without these options with extra interrupts and clock stretching added after the eighth falling edge of SCL. These additional interrupts allow the slave software to decide whether it wants to ACK the receive address or data byte, rather than the hardware. This functionality adds support for PMBus™ that was not present on previous versions of this module.

This list describes the steps that need to be taken by slave software to use these options for I<sup>2</sup>C communication. [Figure 32-16](#) displays a module using both address and data holding. [Figure 32-17](#) includes the operation with the SEN bit of the SSPxCON2 register set.

1. S bit of SSPxSTAT is set; SSPxIF is set if interrupt on Start detect is enabled.
2. Matching address with  $R/\overline{W}$  bit clear is clocked in. SSPxIF is set and CKP cleared after the eighth falling edge of SCL.
3. Slave clears SSPxIF.
4. Slave can look at the ACKTIM bit of the SSPxCON3 register to determine if SSPxIF was after or before the  $\overline{ACK}$ .
5. Slave reads the address value from SSPxBUF, clearing the BF flag.
6. Slave sets  $\overline{ACK}$  value clocked out to the master by setting ACKDT.
7. Slave releases the clock by setting CKP.
8. SSPxIF is set after an  $\overline{ACK}$ , not after a NACK.
9. If SEN = 1, the slave hardware will stretch the clock after the  $\overline{ACK}$ .
10. Slave clears SSPxIF.

**Note:** SSPxIF is still set after the 9th falling edge of SCL even if there is no clock stretching and BF has been cleared. Only if NACK is sent to master is SSPxIF not set

11. SSPxIF is set and CKP cleared after eighth falling edge of SCL for a received data byte.
12. Slave looks at ACKTIM bit of SSPxCON3 to determine the source of the interrupt.
13. Slave reads the received data from SSPxBUF, clearing BF.
14. Steps 7-14 are the same for each received data byte.
15. Communication is ended by either the slave sending an  $\overline{ACK} = 1$  or the master sending a Stop condition. If a Stop is sent and interrupt on Stop detect is disabled, the slave will only know by polling the P bit of the SSPxSTAT register.

FIGURE 32-14: I<sup>2</sup>C SLAVE, 7-BIT ADDRESS, RECEPTION (SEN = 0, AHEN = 0, DHEN = 0)

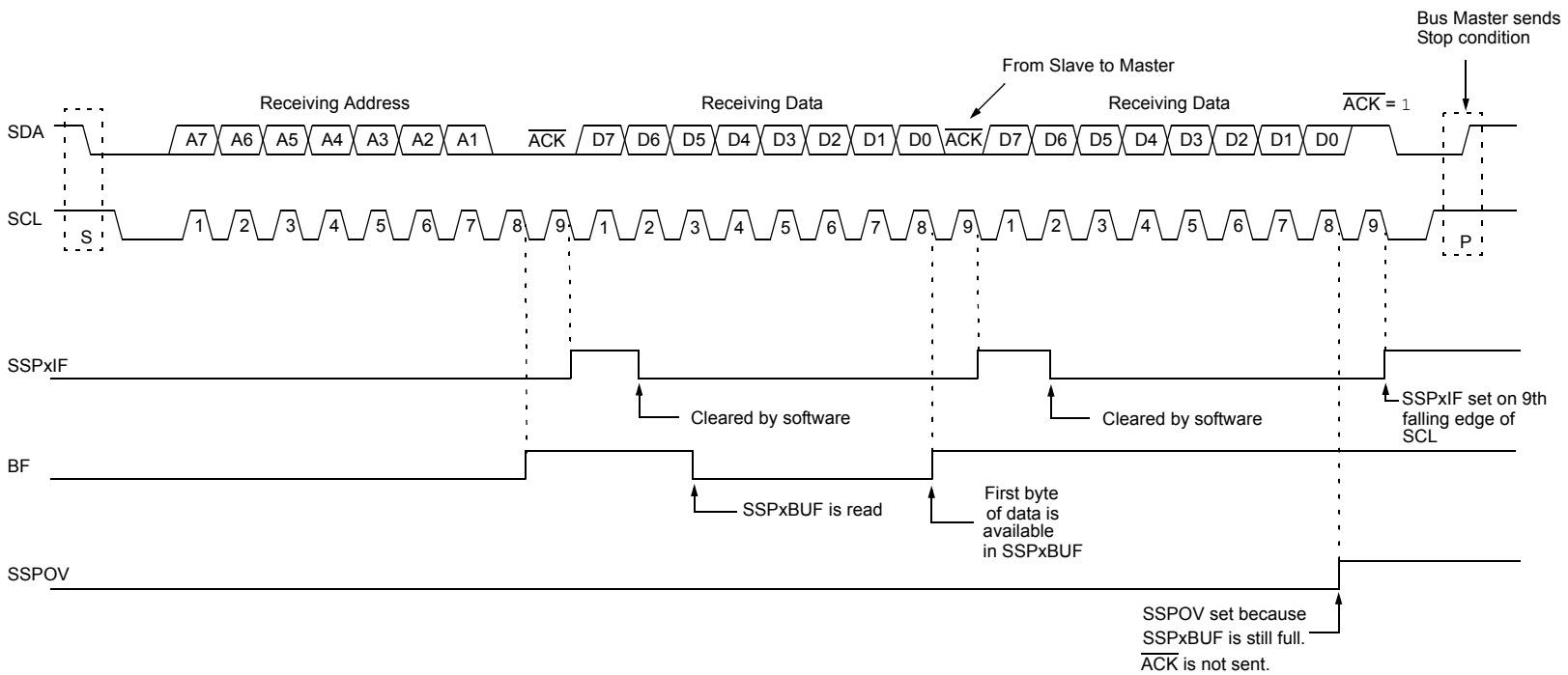


FIGURE 32-15: I<sup>2</sup>C SLAVE, 7-BIT ADDRESS, RECEPTION (SEN = 1, AHEN = 0, DHEN = 0)

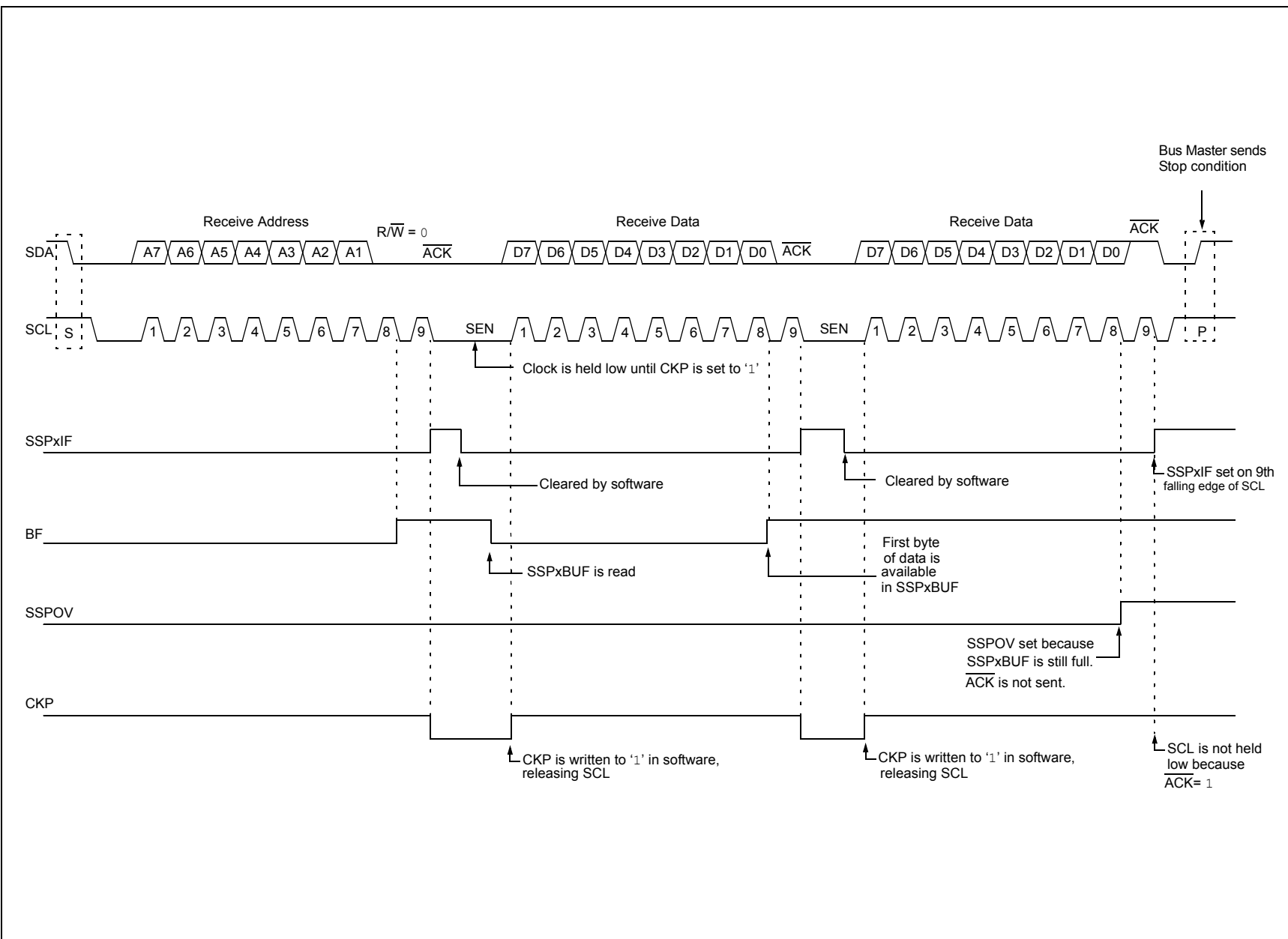


FIGURE 32-16: I<sup>2</sup>C SLAVE, 7-BIT ADDRESS, RECEPTION (SEN = 0, AHEN = 1, DHEN = 1)

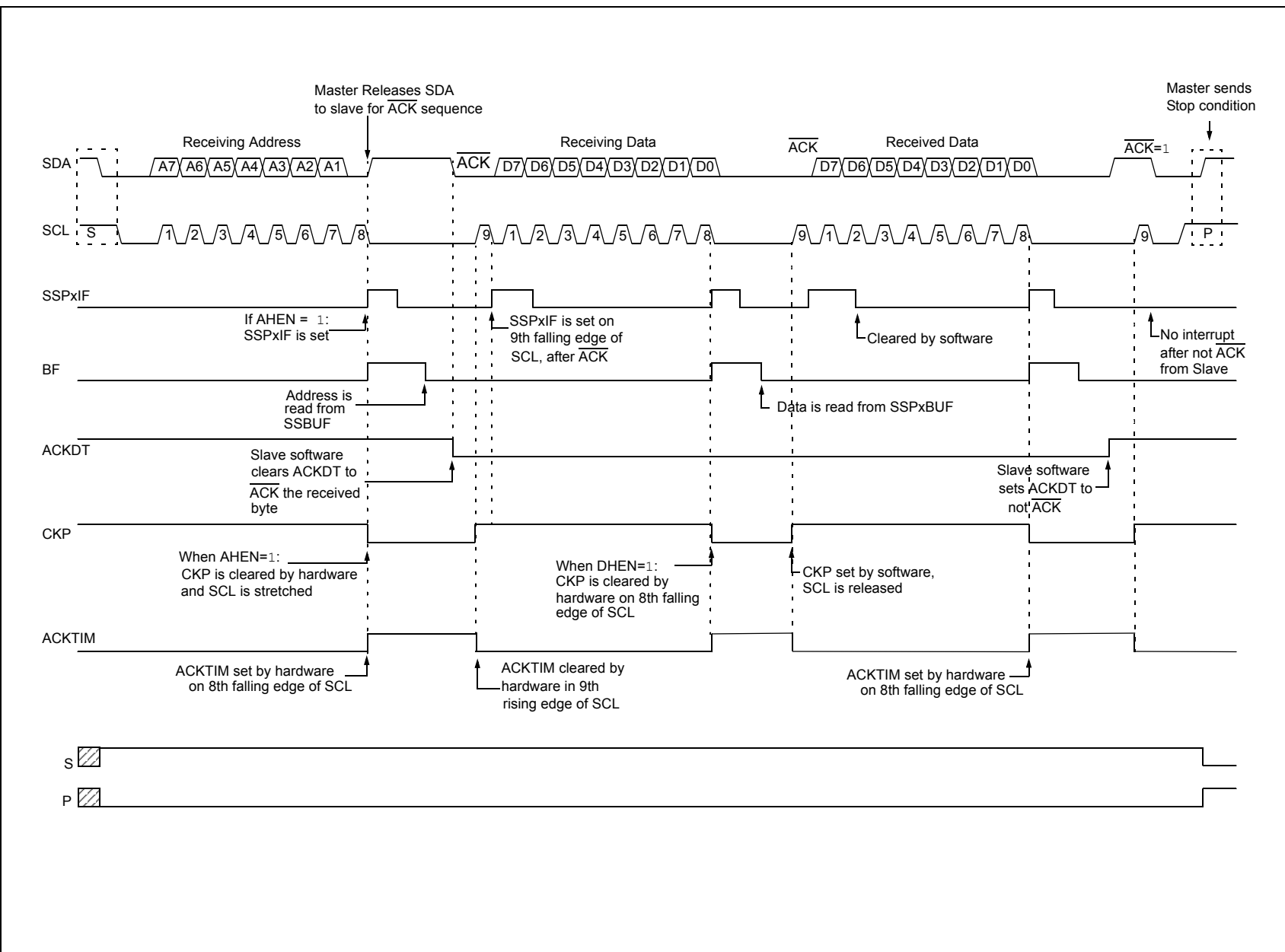
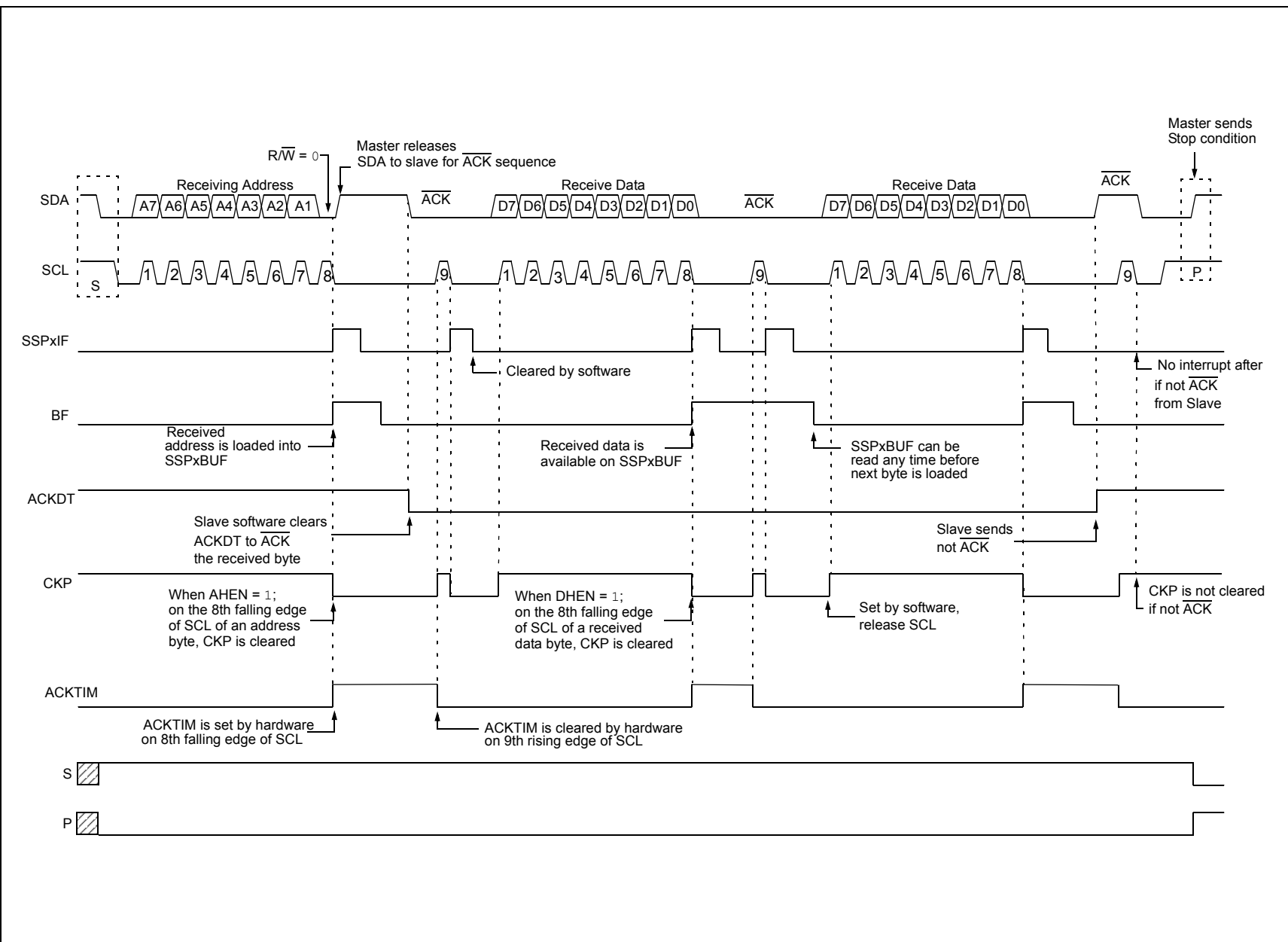




FIGURE 32-17: I<sup>2</sup>C SLAVE, 7-BIT ADDRESS, RECEPTION (SEN = 1, AHEN = 1, DHEN = 1)



## 32.5.3 SLAVE TRANSMISSION

When the  $\overline{R/W}$  bit of the incoming address byte is set and an address match occurs, the  $\overline{R/W}$  bit of the SSPxSTAT register is set. The received address is loaded into the SSPxBUF register, and an  $\overline{ACK}$  pulse is sent by the slave on the ninth bit.

Following the  $\overline{ACK}$ , slave hardware clears the CKP bit and the SCL pin is held low (see [Section 32.5.6 “Clock Stretching”](#) for more detail). By stretching the clock, the master will be unable to assert another clock pulse until the slave is done preparing the transmit data.

The transmit data must be loaded into the SSPxBUF register which also loads the SSPSR register. Then, the SCL pin should be released by setting the CKP bit of the SSPxCON1 register. The eight data bits are shifted out on the falling edge of the SCL input. This ensures that the SDA signal is valid during the SCL high time.

The  $\overline{ACK}$  pulse from the master-receiver is latched on the rising edge of the ninth SCL input pulse. This  $\overline{ACK}$  value is copied to the ACKSTAT bit of the SSPxCON2 register. If ACKSTAT is set (not  $\overline{ACK}$ ), then the data transfer is complete. In this case, when the not  $\overline{ACK}$  is latched by the slave, the slave goes Idle and waits for another occurrence of the Start bit. If the SDA line was low ( $\overline{ACK}$ ), the next transmit data must be loaded into the SSPxBUF register. Again, the SCL pin must be released by setting bit CKP.

An MSSP interrupt is generated for each data transfer byte. The SSPxIF bit must be cleared by software and the SSPxSTAT register is used to determine the status of the byte. The SSPxIF bit is set on the falling edge of the ninth clock pulse.

### 32.5.3.1 Slave Mode Bus Collision

A slave receives a read request and begins shifting data out on the SDA line. If a bus collision is detected and the SBCDE bit of the SSPxCON3 register is set, the BCLIF bit of the PIR register is set. Once a bus collision is detected, the slave goes Idle and waits to be addressed again. User software can use the BCLIF bit to handle a slave bus collision.

### 32.5.3.2 7-Bit Transmission

A master device can transmit a read request to a slave and then clock data out of the slave. The list below outlines what software for a slave will need to do to accomplish a standard transmission. [Figure 32-18](#) can be used as a reference to this list.

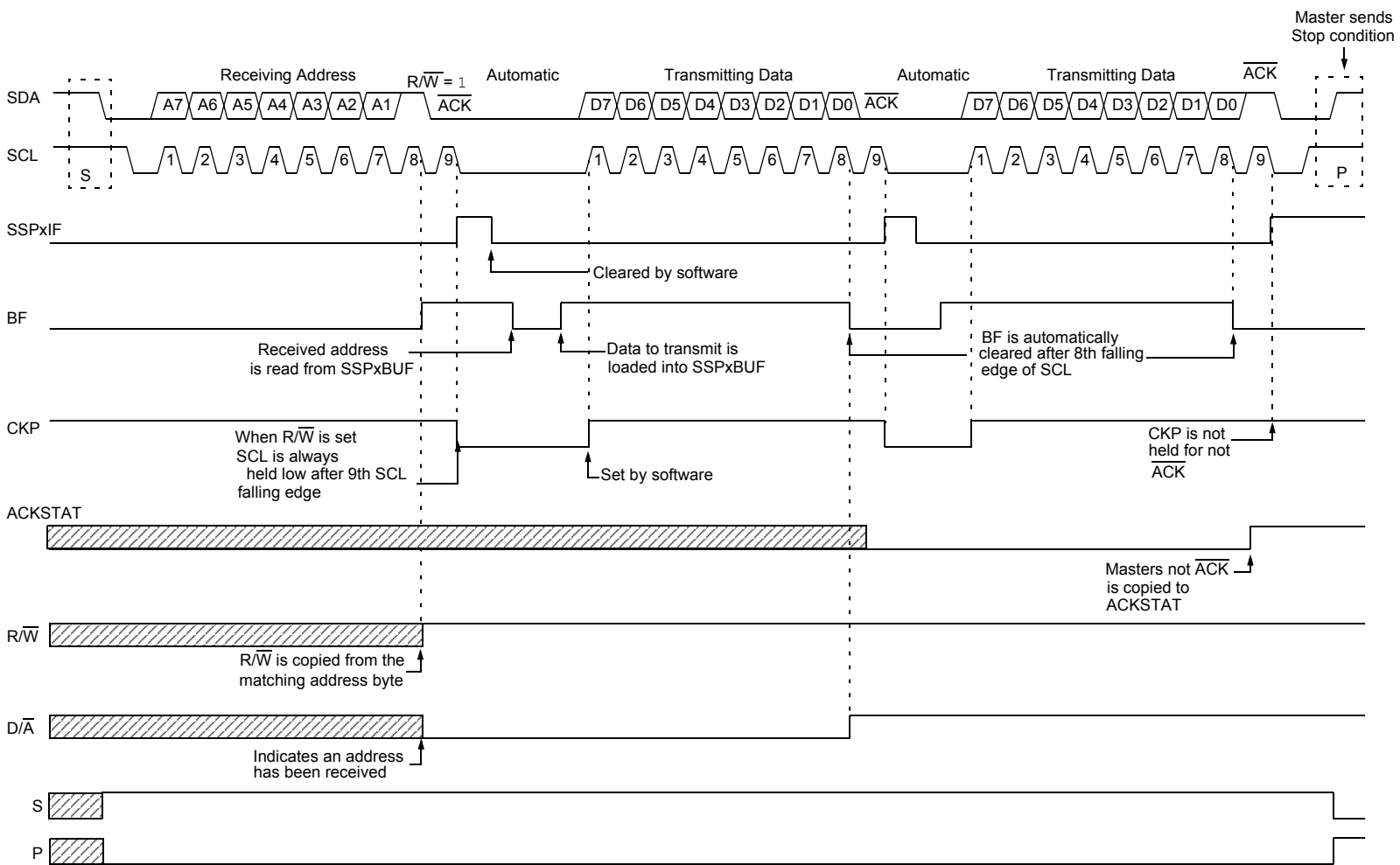
1. Master sends a Start condition on SDA and SCL.
2. S bit of SSPxSTAT is set; SSPxIF is set if interrupt on Start detect is enabled.
3. Matching address with  $\overline{R/W}$  bit set is received by the slave, setting SSPxIF bit.
4. Slave hardware generates an  $\overline{ACK}$  and sets SSPxIF.
5. SSPxIF bit is cleared by user.
6. Software reads the received address from SSPxBUF, clearing BF.
7.  $\overline{R/W}$  is set so CKP was automatically cleared after the  $\overline{ACK}$ .
8. The slave software loads the transmit data into SSPxBUF.
9. CKP bit is set, releasing SCL, allowing the master to clock the data out of the slave.
10. SSPxIF is set after the  $\overline{ACK}$  response from the master is loaded into the ACKSTAT register.
11. SSPxIF bit is cleared.
12. The slave software checks the ACKSTAT bit to see if the master wants to clock out more data.

**Note 1:** If the master  $\overline{ACK}$ s, the clock will be stretched.

**2:** ACKSTAT is the only bit updated on the rising edge of SCL (9th), rather than the falling.

13. Steps 9-13 are repeated for each transmitted byte.
14. If the master sends a not  $\overline{ACK}$ , the clock is not held, but SSPxIF is still set.
15. The master sends a Restart condition or a Stop.
16. The slave is no longer addressed.

FIGURE 32-18: I<sup>2</sup>C SLAVE, 7-BIT ADDRESS, TRANSMISSION (AHEN = 0)



### 32.5.3.3 7-Bit Transmission with Address Hold Enabled

Setting the AHEN bit of the SSPxCON3 register enables additional clock stretching and interrupt generation after the eighth falling edge of a received matching address. Once a matching address has been clocked in, CKP is cleared and the SSPxIF interrupt is set.

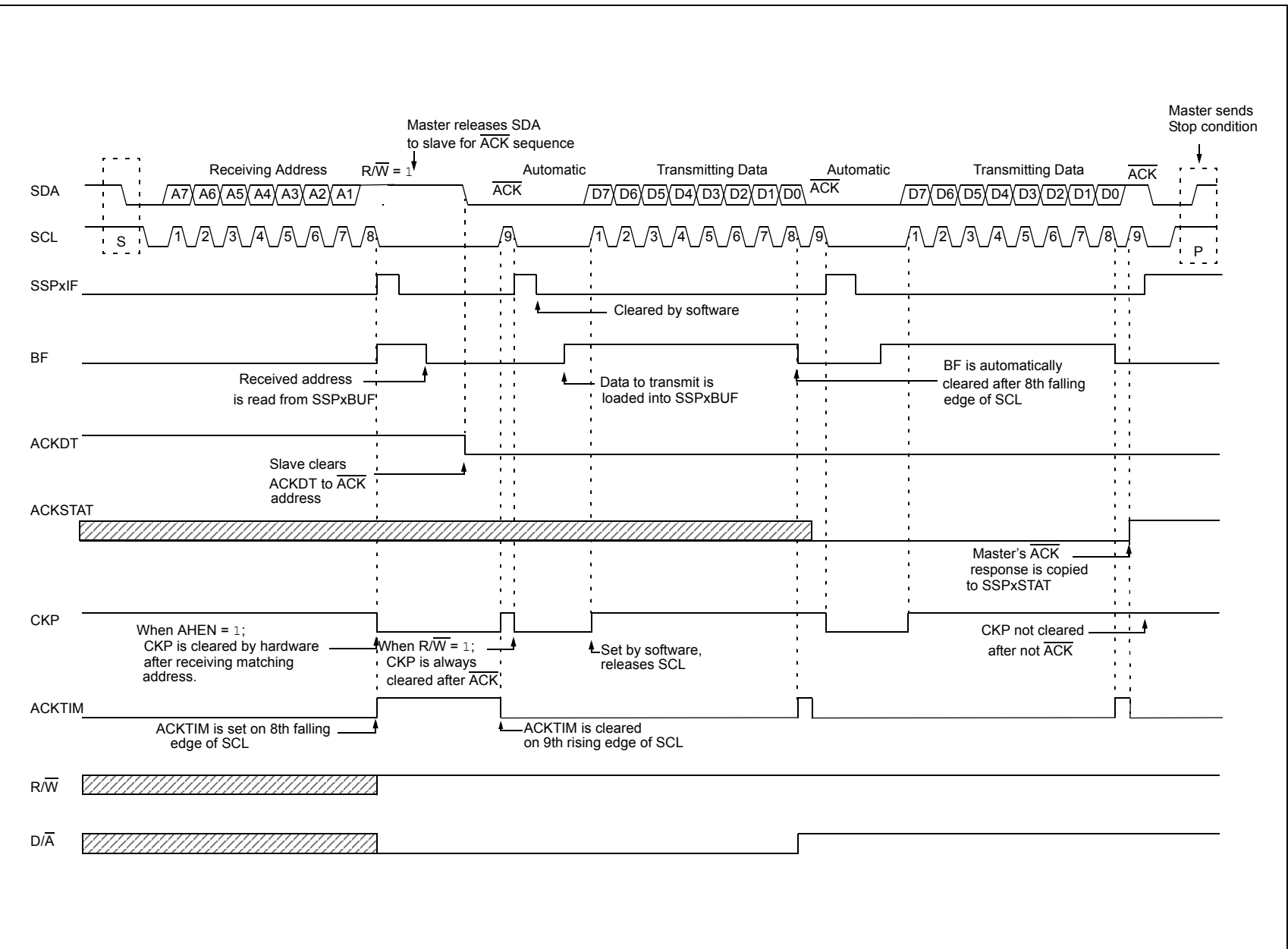
Figure 32-19 displays a standard waveform of a 7-bit address slave transmission with AHEN enabled.

1. Bus starts Idle.
2. Master sends Start condition; the S bit of SSPxSTAT is set; SSPxIF is set if interrupt on Start detect is enabled.
3. Master sends matching address with  $\overline{R/W}$  bit set. After the eighth falling edge of the SCL line, the CKP bit is cleared and the SSPxIF interrupt is generated.
4. Slave software clears SSPxIF.
5. Slave software reads the ACKTIM bit of SSPxCON3, and  $\overline{R/W}$  and  $\overline{D/A}$  of the SSPxSTAT register to determine the source of the interrupt.
6. Slave reads the address value from the SSPxBUF register, clearing the BF bit.
7. Slave software decides from this information if it wishes to ACK or not ACK and sets the ACKDT bit of the SSPxCON2 register accordingly.
8. Slave sets the CKP bit, releasing SCL.
9. Master clocks in the  $\overline{ACK}$  value from the slave.
10. Slave hardware automatically clears the CKP bit and sets SSPxIF after the ACK if the R/W bit is set.
11. Slave software clears SSPxIF.
12. Slave loads value to transmit to the master into SSPxBUF, setting the BF bit.
13. Slave sets the CKP bit, releasing the clock.
14. Master clocks out the data from the slave and sends an  $\overline{ACK}$  value on the 9th SCL pulse.
15. Slave hardware copies the  $\overline{ACK}$  value into the ACKSTAT bit of the SSPxCON2 register.
16. Steps 10-15 are repeated for each byte transmitted to the master from the slave.
17. If the master sends a not  $\overline{ACK}$ , the slave releases the bus allowing the master to send a Stop and end the communication.

**Note:** SSPxBUF cannot be loaded until after the  $\overline{ACK}$ .

**Note:** Master must send a not  $\overline{ACK}$  on the last byte to ensure that the slave releases the SCL line to receive a Stop.

FIGURE 32-19: I<sup>2</sup>C SLAVE, 7-BIT ADDRESS, TRANSMISSION (AHEN = 1)



## 32.5.4 SLAVE MODE 10-BIT ADDRESS RECEPTION

This section describes a standard sequence of events for the MSSP module configured as an I<sup>2</sup>C slave in 10-Bit Addressing mode.

Figure 32-20 is used as a visual reference for this description.

This is a step by step process of what must be done by slave software to accomplish I<sup>2</sup>C communication.

1. Bus starts Idle.
2. Master sends Start condition. S bit of SSPxSTAT is set; SSPxIF is set if interrupt on Start detect is enabled.
3. Master sends matching high address with  $\overline{R/W}$  bit clear; UA bit of the SSPxSTAT register is set.
4. Slave sends  $\overline{ACK}$  and SSPxIF is set.
5. Software clears the SSPxIF bit.
6. Software reads received address from SSPxBUF, clearing the BF flag.
7. Slave loads low address into SSPxADD, releasing SCL.
8. Master sends matching low address byte to the slave; UA bit is set.

**Note:** Updates to the SSPxADD register are not allowed until after the  $\overline{ACK}$  sequence.

9. Slave sends  $\overline{ACK}$  and SSPxIF is set.

**Note:** If the low address does not match, SSPxIF and UA are still set so that the slave software can set SSPxADD back to the high address. BF is not set because there is no match. CKP is unaffected.

10. Slave clears SSPxIF.
11. Slave reads the received matching address from SSPxBUF, clearing BF.
12. Slave loads high address into SSPxADD.
13. Master clocks a data byte to the slave and clocks out the slave's  $\overline{ACK}$  on the 9th SCL pulse; SSPxIF is set.
14. If SEN bit of SSPxCON2 is set, CKP is cleared by hardware and the clock is stretched.
15. Slave clears SSPxIF.
16. Slave reads the received byte from SSPxBUF, clearing BF.
17. If SEN is set, the slave sets CKP to release the SCL.
18. Steps 13-17 repeat for each received byte.
19. Master sends Stop to end the transmission.

## 32.5.5 10-BIT ADDRESSING WITH ADDRESS OR DATA HOLD

Reception using 10-Bit Addressing with AHEN or DHEN set is the same as with 7-bit modes. The only difference is the need to update the SSPxADD register using the UA bit. All functionality, specifically when the CKP bit is cleared and the SCL line is held low, are the same. Figure 32-21 can be used as a reference of a slave in 10-Bit Addressing with AHEN set.

Figure 32-22 shows a standard waveform for a slave transmitter in 10-Bit Addressing mode.

FIGURE 32-20: I<sup>2</sup>C SLAVE, 10-BIT ADDRESS, RECEPTION (SEN = 1, AHEN = 0, DHEN = 0)

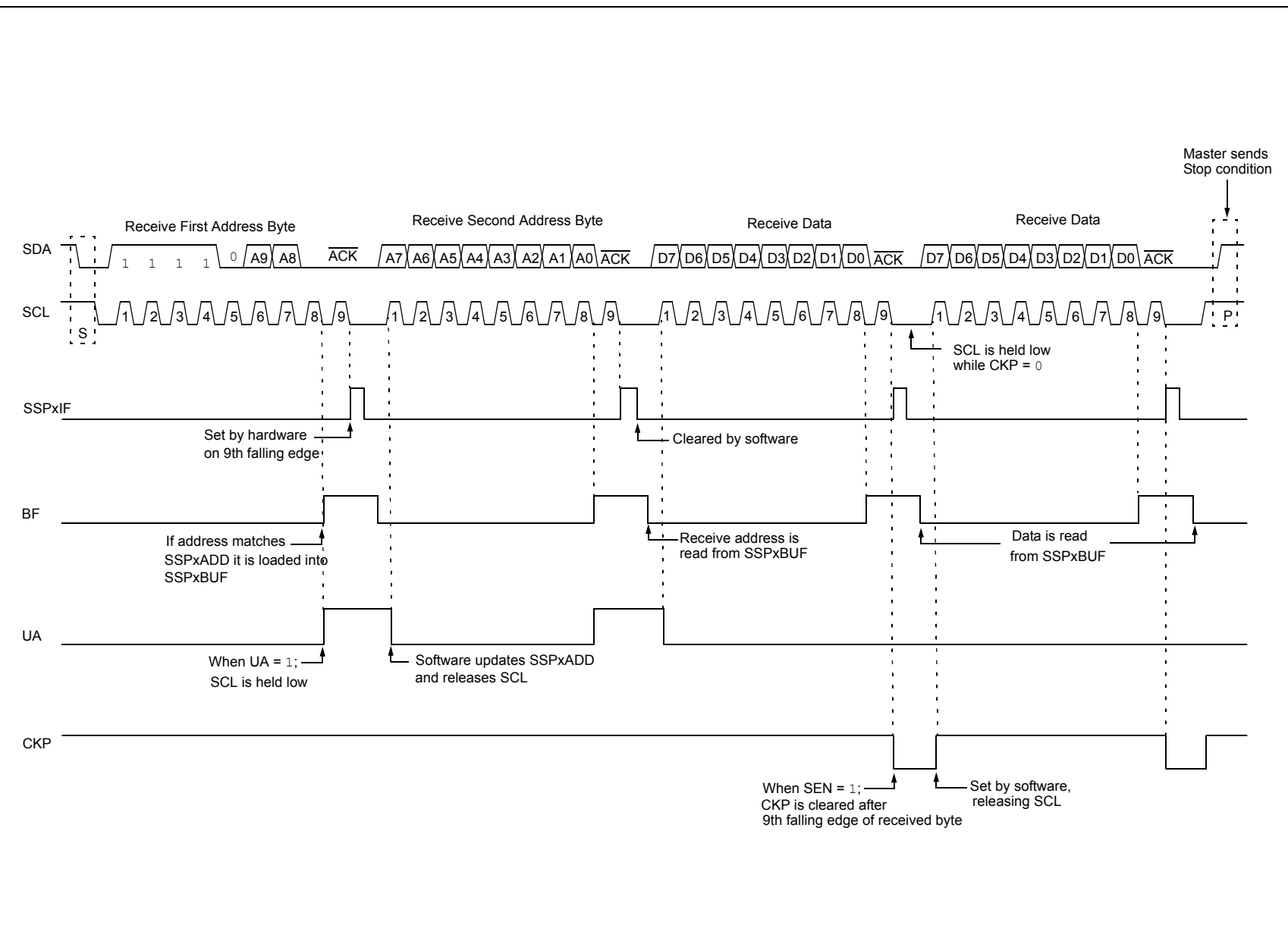


FIGURE 32-21: I<sup>2</sup>C SLAVE, 10-BIT ADDRESS, RECEPTION (SEN = 0, AHEN = 1, DHEN = 0)

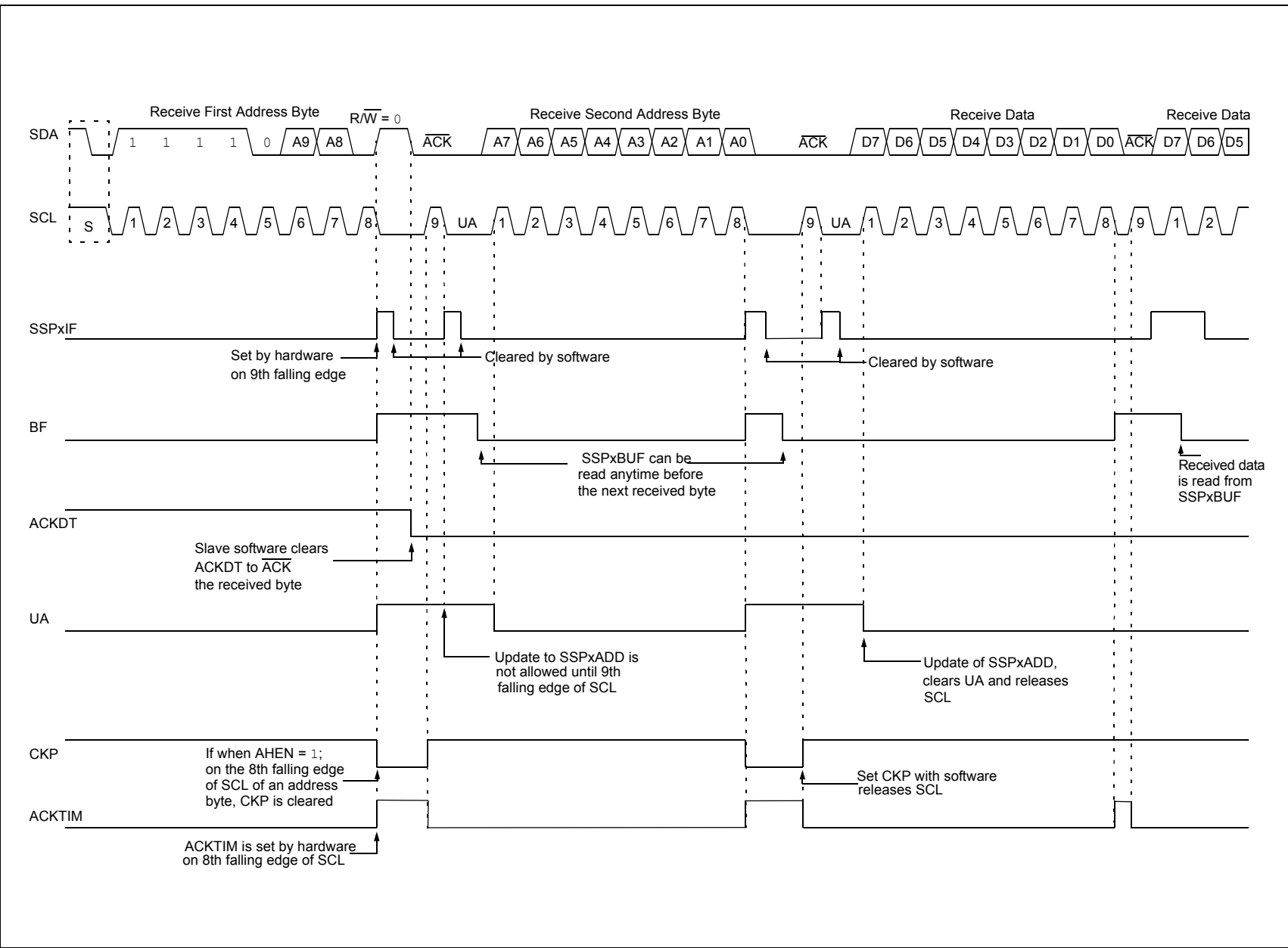
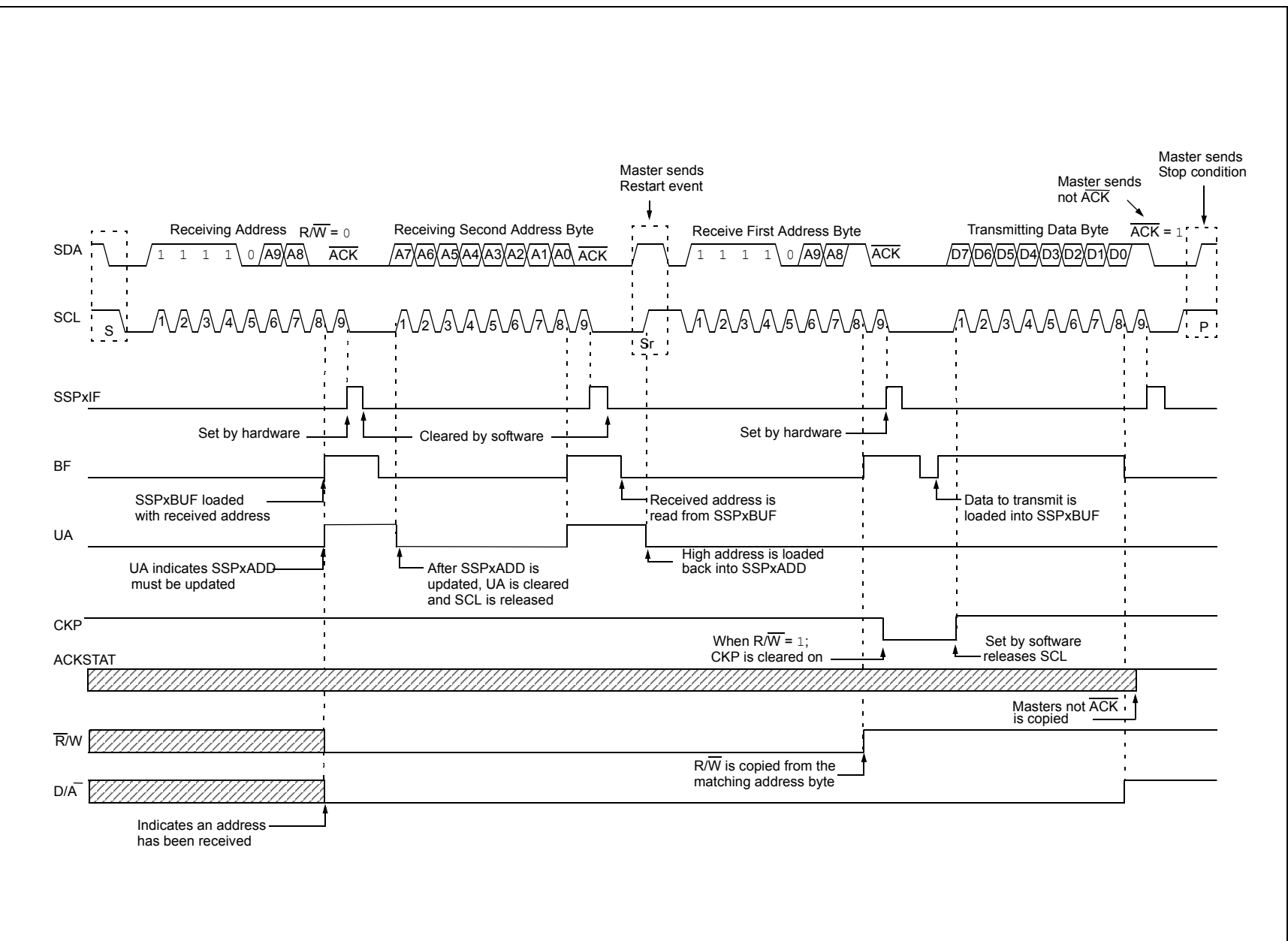




FIGURE 32-22: I<sup>2</sup>C SLAVE, 10-BIT ADDRESS, TRANSMISSION (SEN = 0, AHEN = 0, DHEN = 0)



## 32.5.6 CLOCK STRETCHING

Clock stretching occurs when a device on the bus holds the SCL line low, effectively pausing communication. The slave may stretch the clock to allow more time to handle data or prepare a response for the master device. A master device is not concerned with stretching, as anytime it is active on the bus and not transferring data, it is stretching. Any stretching done by a slave is invisible to the master software and handled by the hardware that generates SCL.

The CKP bit of the SSPxCON1 register is used to control stretching in software. Any time the CKP bit is cleared, the module will wait for the SCL line to go low and then hold it. Setting CKP will release SCL and allow more communication.

### 32.5.6.1 Normal Clock Stretching

Following an  $\overline{\text{ACK}}$ , if the  $\overline{\text{R/W}}$  bit of SSPxSTAT is set and there is a read request, the slave hardware will clear CKP. This allows the slave time to update SSPxBUF with data to transfer to the master. If the SEN bit of SSPxCON2 is set, the slave hardware will always stretch the clock after the  $\overline{\text{ACK}}$  sequence. Once the slave is ready, CKP is set by software and communication resumes.

- Note 1:** The BF bit has no effect on if the clock will be stretched or not. This is different than previous versions of the module that would not stretch the clock, and cleared CKP if SSPxBUF was read before the 9th falling edge of SCL.
- 2:** Previous versions of the module did not stretch the clock for a transmission if SSPxBUF was loaded before the 9th falling edge of SCL; it is now always cleared for read requests.

### 32.5.6.2 10-Bit Addressing Mode

In 10-Bit Addressing mode when the UA bit is set, the clock is always stretched. This is the only time the SCL is stretched without CKP being cleared. SCL is released immediately after a write to SSPxADD.

**Note:** Previous versions of the module did not stretch the clock if the second address byte did not match.

### 32.5.6.3 Byte NACKing

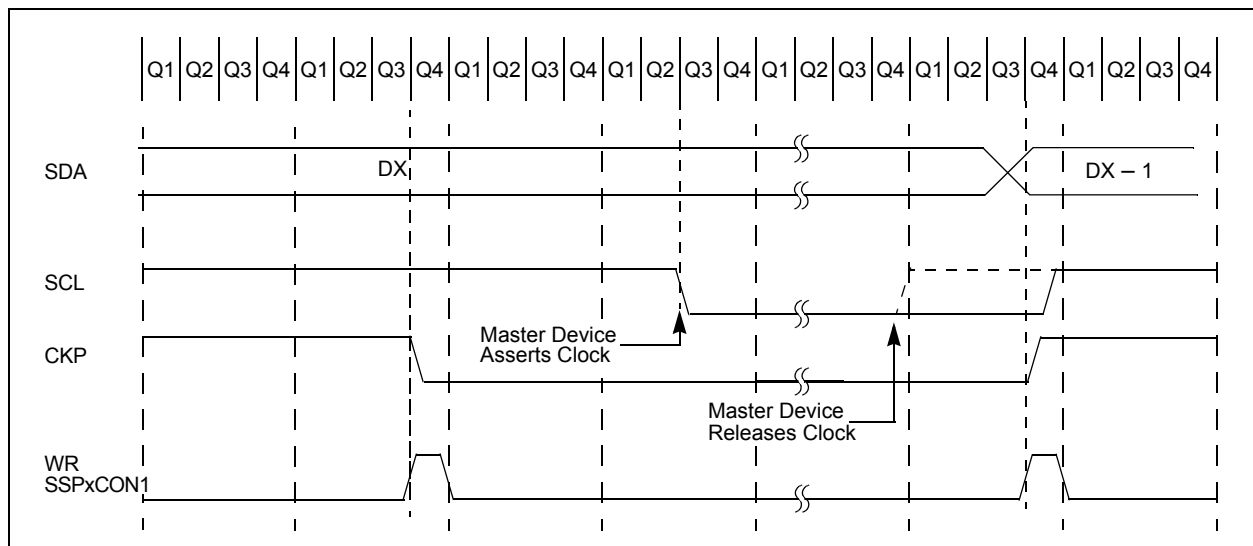
When the AHEN bit of SSPxCON3 is set, CKP is cleared by hardware after the eighth falling edge of SCL for a received matching address byte. When the DHEN bit of SSPxCON3 is set, CKP is cleared after the eighth falling edge of SCL for received data.

Stretching after the eighth falling edge of SCL allows the slave to look at the received address or data and decide if it wants to ACK the received data.

### 32.5.6.4 Clock Synchronization and the CKP Bit

Any time the CKP bit is cleared, the module will wait for the SCL line to go low and then hold it. However, clearing the CKP bit will not assert the SCL output low until the SCL output is already sampled low. Therefore, the CKP bit will not assert the SCL line until an external I<sup>2</sup>C master device has already asserted the SCL line. The SCL output will remain low until the CKP bit is set and all other devices on the I<sup>2</sup>C bus have released SCL. This ensures that a write to the CKP bit will not violate the minimum high time requirement for SCL (see [Figure 32-23](#)).

**FIGURE 32-23: CLOCK SYNCHRONIZATION TIMING**



## 32.5.7 GENERAL CALL ADDRESS SUPPORT

The addressing procedure for the I<sup>2</sup>C bus is such that the first byte after the Start condition usually determines which device will be the slave addressed by the master device. The exception is the general call address which can address all devices. When this address is used, all devices should, in theory, respond with an Acknowledge.

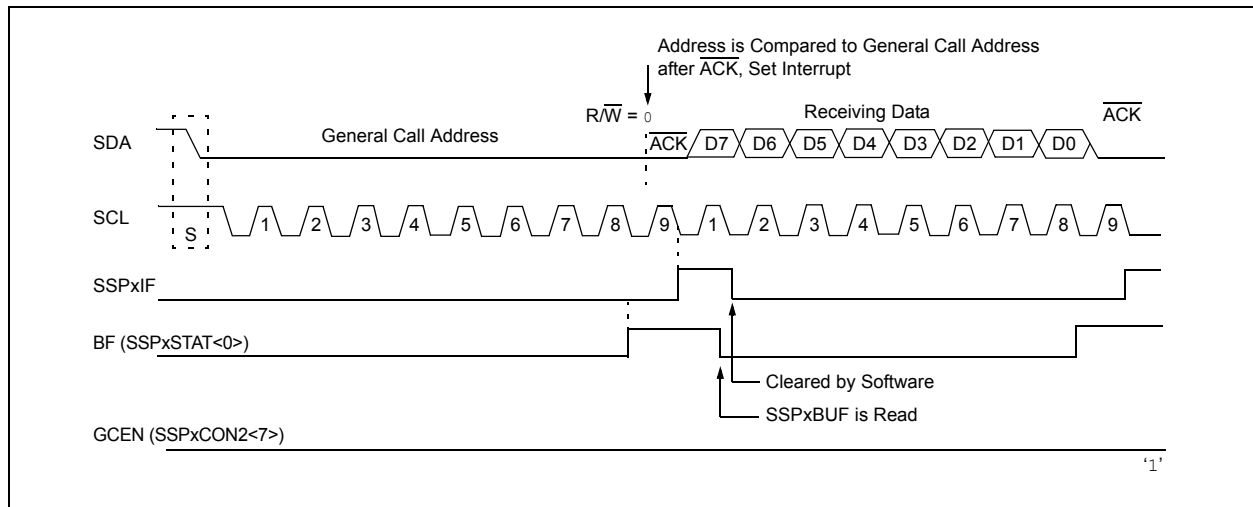
The general call address is a reserved address in the I<sup>2</sup>C protocol, defined as address: 0x00. When the GCEN bit of the SSPxCON2 register is set, the slave module will automatically  $\overline{\text{ACK}}$  the reception of this address, regardless of the value stored in SSPxADD. After the slave clocks in an address of all zeros, with the

$\overline{\text{R}/\overline{\text{W}}}$  bit clear, an interrupt is generated and slave software can read SSPxBUF and respond. Figure 32-24 shows a general call reception sequence.

In 10-Bit Address mode, the UA bit will not be set on the reception of the general call address. The slave will prepare to receive the second byte as data, just as it would in 7-bit mode.

If the AHEN bit of the SSPxCON3 register is set, just as with any other address reception, the slave hardware will stretch the clock after the eighth falling edge of SCL. The slave must then set its ACKDT value and release the clock with communication progressing as it would normally.

**FIGURE 32-24: SLAVE MODE GENERAL CALL ADDRESS SEQUENCE**



## 32.5.8 SSP MASK REGISTER

An MSSP Mask (SSPxMSK) register (Register 32-5) is available in I<sup>2</sup>C Slave mode as a mask for the value held in the SSPSR register during an address comparison operation. A zero ('0') bit in the SSPxMSK register has the effect of making the corresponding bit of the received address a "don't care".

This register is reset to all '1's upon any Reset condition, and therefore, has no effect on standard SSP operation until written with a mask value.

The MSSP Mask register is active during:

- 7-Bit Address mode: Address compare of A<7:1>.
- 10-Bit Address mode: Address compare of A<7:0> only. The MSSP mask has no effect during the reception of the first (high) byte of the address.

## 32.6 I<sup>2</sup>C Master Mode

Master mode is enabled by setting and clearing the appropriate SSPM<3:0> bits in the SSPxCON1 register and by setting the SSPEN bit. In Master mode, the SDA and SCK pins must be configured as inputs. The MSSP peripheral hardware will override the output driver TRIS controls when necessary to drive the pins low.

Master mode of operation is supported by interrupt generation on the detection of the Start and Stop conditions. The Stop (P) and Start (S) bits are cleared from a Reset or when the MSSP module is disabled. Control of the I<sup>2</sup>C bus may be taken when the P bit is set or the bus is Idle.

In Firmware Controlled Master mode, user code conducts all I<sup>2</sup>C bus operations based on Start and Stop bit condition detection. Start and Stop condition detection is the only active circuitry in this mode. All other communication is done by the user software directly manipulating the SDA and SCL lines.

The following events will cause the SSP Interrupt Flag bit, SSPxIF, to be set (SSP interrupt, if enabled):

- Start condition detected
- Stop condition detected
- Data transfer byte transmitted/received
- Acknowledge transmitted/received
- Repeated Start generated

**Note 1:** The MSSP module, when configured in I<sup>2</sup>C Master mode, does not allow queuing of events. For instance, the user is not allowed to initiate a Start condition and immediately write the SSPxBUF register to initiate transmission before the Start condition is complete. In this case, the SSPxBUF will not be written to and the WCOL bit will be set, indicating that a write to the SSPxBUF did not occur

- 2:** Master mode suspends Start/Stop detection when sending the Start/Stop condition by means of the SEN/PEN control bits. The SSPxIF bit is set at the end of the Start/Stop generation when hardware clears the control bit.

### 32.6.1 I<sup>2</sup>C MASTER MODE OPERATION

The master device generates all of the serial clock pulses, and the Start and Stop conditions. A transfer is ended with a Stop condition or with a Repeated Start condition. Since the Repeated Start condition is also the beginning of the next serial transfer, the I<sup>2</sup>C bus will not be released.

In Master Transmitter mode, serial data is output through SDA, while SCL outputs the serial clock. The first byte transmitted contains the slave address of the receiving device (7 bits) and the Read/Write (R/W) bit. In this case, the R/W bit will be logic '0'. Serial data is transmitted, eight bits at a time. After each byte is transmitted, an Acknowledge bit is received. Start and Stop conditions are output to indicate the beginning and the end of a serial transfer.

In Master Receive mode, the first byte transmitted contains the slave address of the transmitting device (7 bits) and the R/W bit. In this case, the R/W bit will be logic '1'. Thus, the first byte transmitted is a 7-bit slave address followed by a '1' to indicate the receive bit. Serial data is received via SDA, while SCL outputs the serial clock. Serial data is received eight bits at a time. After each byte is received, an Acknowledge bit is transmitted. Start and Stop conditions indicate the beginning and end of transmission.

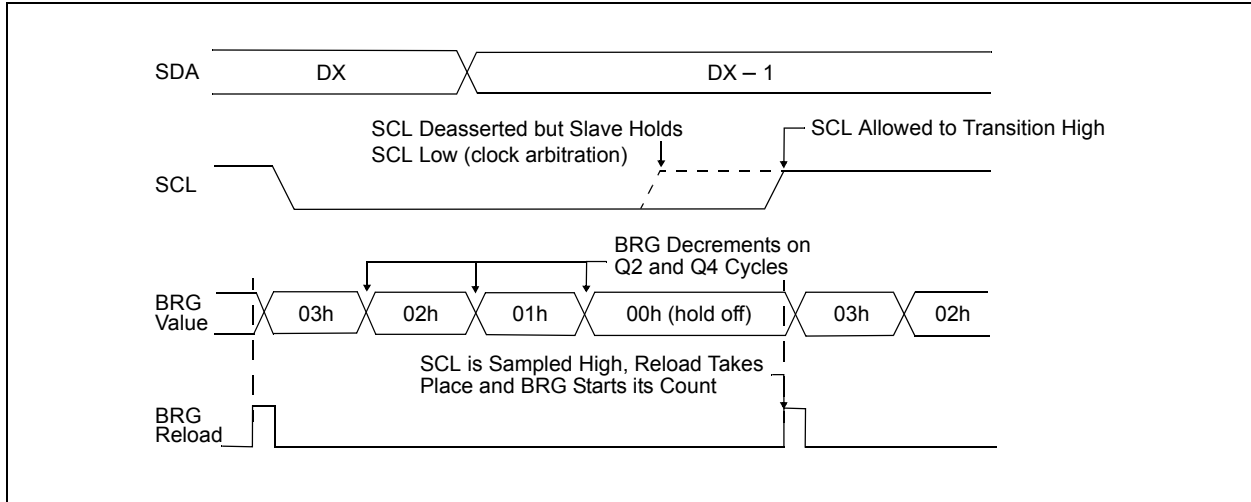
A Baud Rate Generator is used to set the clock frequency output on SCL. See [Section 32.7 "Baud Rate Generator"](#) for more detail.

## 32.6.2 CLOCK ARBITRATION

Clock arbitration occurs when the master, during any receive, transmit or Repeated Start/Stop condition, releases the SCL pin (SCL allowed to float high). When the SCL pin is allowed to float high, the Baud Rate Generator (BRG) is suspended from counting until the

SCL pin is actually sampled high. When the SCL pin is sampled high, the Baud Rate Generator is reloaded with the contents of SSPxADD<7:0> and begins counting. This ensures that the SCL high time will always be at least one BRG rollover count in the event that the clock is held low by an external device (Figure 32-25).

**FIGURE 32-25: BAUD RATE GENERATOR TIMING WITH CLOCK ARBITRATION**



## 32.6.3 WCOL STATUS FLAG

If the user writes the SSPxBUF when a Start, Restart, Stop, receive or transmit sequence is in progress, the WCOL is set and the contents of the buffer are unchanged (the write does not occur). Any time the WCOL bit is set, it indicates that an action on SSPxBUF was attempted while the module was not Idle.

**Note:** Because queuing of events is not allowed, writing to the lower five bits of SSPxCON2 is disabled until the Start condition is complete.

## 32.6.4 I<sup>2</sup>C MASTER MODE START CONDITION TIMING

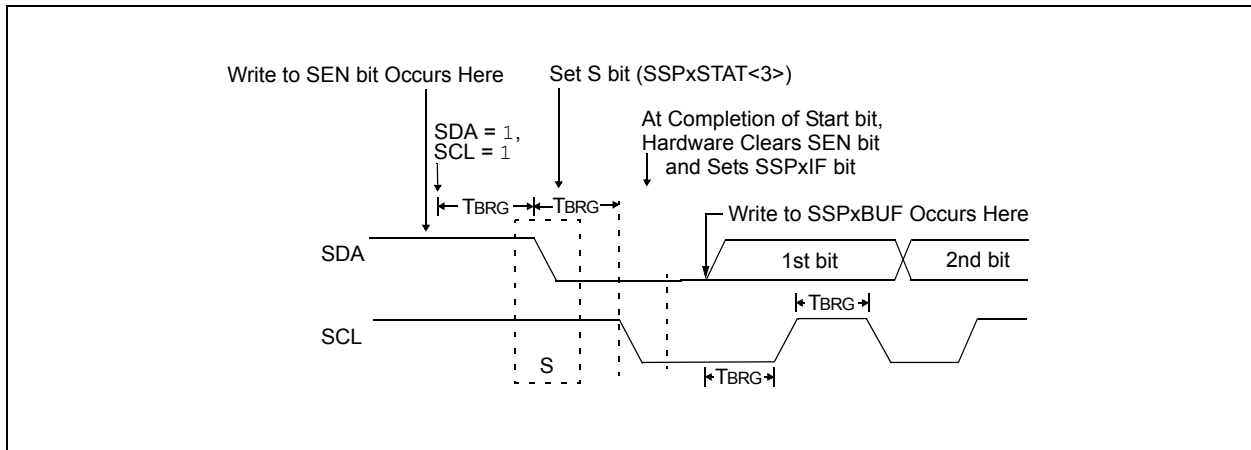
To initiate a Start condition (Figure 32-26), the user sets the Start Enable bit, SEN, of the SSPxCON2 register. If the SDA and SCL pins are sampled high, the Baud Rate Generator is reloaded with the contents of SSPxADD<7:0> and starts its count. If SCL and SDA are both sampled high when the Baud Rate Generator times out (TBRG), the SDA pin is driven low. The action of the SDA being driven low while SCL is high is the Start condition and causes the S bit of the SSPxSTAT register to be set. Following this, the Baud Rate Generator is reloaded with the contents of SSPxADD<7:0> and resumes its count. When the Baud Rate Generator times out (TBRG), the SEN bit of the SSPxCON2 register will be automatically cleared

by hardware; the Baud Rate Generator is suspended, leaving the SDA line held low and the Start condition is complete.

**Note 1:** If, at the beginning of the Start condition, the SDA and SCL pins are already sampled low, or if during the Start condition, the SCL line is sampled low before the SDA line is driven low, a bus collision occurs. The Bus Collision Interrupt Flag, BCLIF, is set, the Start condition is aborted and the I<sup>2</sup>C module is reset into its Idle state.

**2:** The Philips I<sup>2</sup>C specification states that a bus collision cannot occur on a Start.

**FIGURE 32-26: FIRST START BIT TIMING**





## 32.6.6 I<sup>2</sup>C MASTER MODE TRANSMISSION

Transmission of a data byte, a 7-bit address or the other half of a 10-bit address is accomplished by simply writing a value to the SSPxBUF register. This action will set the Buffer Full flag bit, BF, and allow the Baud Rate Generator to begin counting and start the next transmission. Each bit of address/data will be shifted out onto the SDA pin after the falling edge of SCL is asserted. SCL is held low for one Baud Rate Generator rollover count (TBRG). Data should be valid before SCL is released high. When the SCL pin is released high, it is held that way for TBRG. The data on the SDA pin must remain stable for that duration and some hold time after the next falling edge of SCL. After the eighth bit is shifted out (the falling edge of the eighth clock), the BF flag is cleared and the master releases SDA. This allows the slave device being addressed to respond with an ACK bit during the ninth bit time if an address match occurred or if data was received properly. The status of ACK is written into the ACKSTAT bit on the rising edge of the ninth clock. If the master receives an Acknowledge, the Acknowledge status bit, ACKSTAT, is cleared. If not, the bit is set. After the ninth clock, the SSPxIF bit is set and the master clock (Baud Rate Generator) is suspended until the next data byte is loaded into the SSPxBUF, leaving SCL low and SDA unchanged (Figure 32-28).

After the write to the SSPxBUF, each bit of the address will be shifted out on the falling edge of SCL until all seven address bits and the R/W bit are completed. On the falling edge of the eighth clock, the master will release the SDA pin, allowing the slave to respond with an Acknowledge. On the falling edge of the ninth clock, the master will sample the SDA pin to see if the address was recognized by a slave. The status of the ACK bit is loaded into the ACKSTAT status bit of the SSPxCON2 register. Following the falling edge of the ninth clock transmission of the address, the SSPxIF is set, the BF flag is cleared and the Baud Rate Generator is turned off until another write to the SSPxBUF takes place, holding SCL low and allowing SDA to float.

### 32.6.6.1 BF Status Flag

In Transmit mode, the BF bit of the SSPxSTAT register is set when the CPU writes to SSPxBUF and is cleared when all eight bits are shifted out.

### 32.6.6.2 WCOL Status Flag

If the user writes the SSPxBUF when a transmit is already in progress (i.e., SSPSR is still shifting out a data byte), the WCOL bit is set and the contents of the buffer are unchanged (the write does not occur).

WCOL must be cleared by software before the next transmission.

### 32.6.6.3 ACKSTAT Status Flag

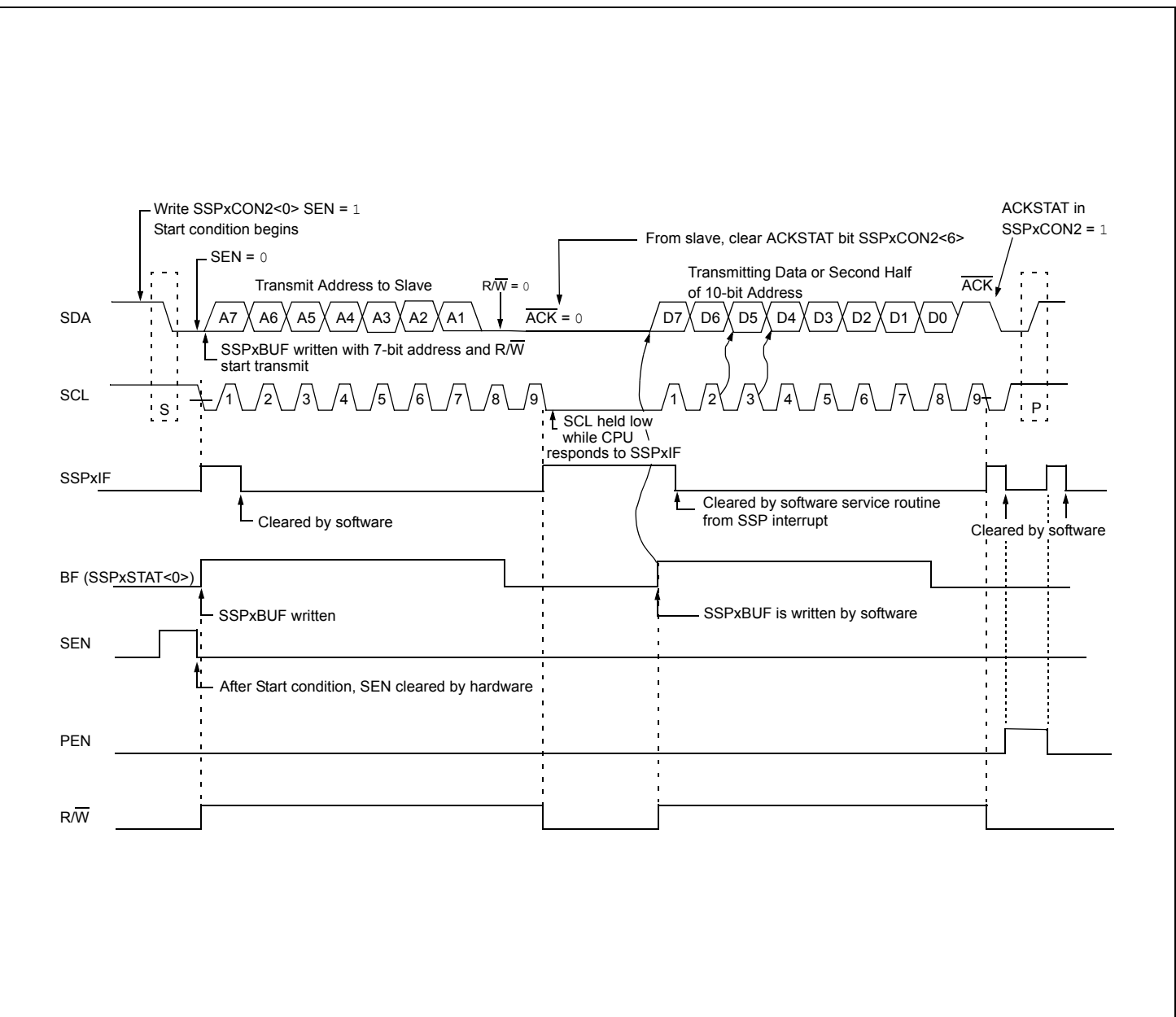
In Transmit mode, the ACKSTAT bit of the SSPxCON2 register is cleared when the slave has sent an Acknowledge (ACK = 0) and is set when the slave does not Acknowledge (ACK = 1). A slave sends an Acknowledge when it has recognized its address (including a general call) or when the slave has properly received its data.

### 32.6.6.4 Typical Transmit Sequence:

1. The user generates a Start condition by setting the SEN bit of the SSPxCON2 register.
2. SSPxIF is set by hardware on completion of the Start.
3. SSPxIF is cleared by software.
4. The MSSP module will wait the required start time before any other operation takes place.
5. The user loads the SSPxBUF with the slave address to transmit.
6. Address is shifted out the SDA pin until all eight bits are transmitted. Transmission begins as soon as SSPxBUF is written to.
7. The MSSP module shifts in the ACK bit from the slave device and writes its value into the ACKSTAT bit of the SSPxCON2 register.
8. The MSSP module generates an interrupt at the end of the ninth clock cycle by setting the SSPxIF bit.
9. The user loads the SSPxBUF with eight bits of data.
10. Data is shifted out the SDA pin until all eight bits are transmitted.
11. The MSSP module shifts in the ACK bit from the slave device and writes its value into the ACKSTAT bit of the SSPxCON2 register.
12. Steps 8-11 are repeated for all transmitted data bytes.
13. The user generates a Stop or Restart condition by setting the PEN or RSEN bits of the SSPxCON2 register. Interrupt is generated once the Stop/Restart condition is complete.



FIGURE 32-28: I<sup>2</sup>C MASTER MODE WAVEFORM (TRANSMISSION, 7 OR 10-BIT ADDRESS)



## 32.6.7 I<sup>2</sup>C MASTER MODE RECEPTION

Master mode reception (Figure 32-29) is enabled by programming the Receive Enable bit, RCEN bit of the SSPxCON2 register.

**Note:** The MSSP module must be in an Idle state before the RCEN bit is set or the RCEN bit will be disregarded.

The Baud Rate Generator begins counting and on each rollover, the state of the SCL pin changes (high-to-low/low-to-high), and data is shifted into the SSPSR. After the falling edge of the eighth clock, the receive enable flag is automatically cleared, the contents of the SSPSR are loaded into the SSPxBUF, the BF flag bit is set, the SSPxIF flag bit is set and the Baud Rate Generator is suspended from counting, holding SCL low. The MSSP is now in Idle state awaiting the next command. When the buffer is read by the CPU, the BF flag bit is automatically cleared. The user can then send an Acknowledge bit at the end of reception by setting the Acknowledge Sequence Enable bit, ACKEN, of the SSPxCON2 register.

### 32.6.7.1 BF Status Flag

In receive operation, the BF bit is set when an address or data byte is loaded into SSPxBUF from SSPSR. It is cleared when the SSPxBUF register is read.

### 32.6.7.2 SSPOV Status Flag

In receive operation, the SSPOV bit is set when eight bits are received into the SSPSR and the BF flag bit is already set from a previous reception.

### 32.6.7.3 WCOL Status Flag

If the user writes the SSPxBUF when a receive is already in progress (i.e., SSPSR is still shifting in a data byte), the WCOL bit is set and the contents of the buffer are unchanged (the write does not occur).

### 32.6.7.4 Typical Receive Sequence:

1. The user generates a Start condition by setting the SEN bit of the SSPxCON2 register.
2. SSPxIF is set by hardware on completion of the Start.
3. SSPxIF is cleared by software.
4. User writes SSPxBUF with the slave address to transmit and the R/W bit set.
5. Address is shifted out the SDA pin until all eight bits are transmitted. Transmission begins as soon as SSPxBUF is written to.
6. The MSSP module shifts in the  $\overline{ACK}$  bit from the slave device and writes its value into the ACKSTAT bit of the SSPxCON2 register.
7. The MSSP module generates an interrupt at the end of the ninth clock cycle by setting the SSPxIF bit.
8. User sets the RCEN bit of the SSPxCON2 register and the master clocks in a byte from the slave.
9. After the eighth falling edge of SCL, SSPxIF and BF are set.
10. Master clears SSPxIF and reads the received byte from SSPxBUF, clears BF.
11. Master sets  $\overline{ACK}$  value sent to slave in ACKDT bit of the SSPxCON2 register and initiates the  $\overline{ACK}$  by setting the ACKEN bit.
12. Master's  $\overline{ACK}$  is clocked out to the slave and SSPxIF is set.
13. User clears SSPxIF.
14. Steps 8-13 are repeated for each received byte from the slave.
15. Master sends a not  $\overline{ACK}$  or Stop to end communication.

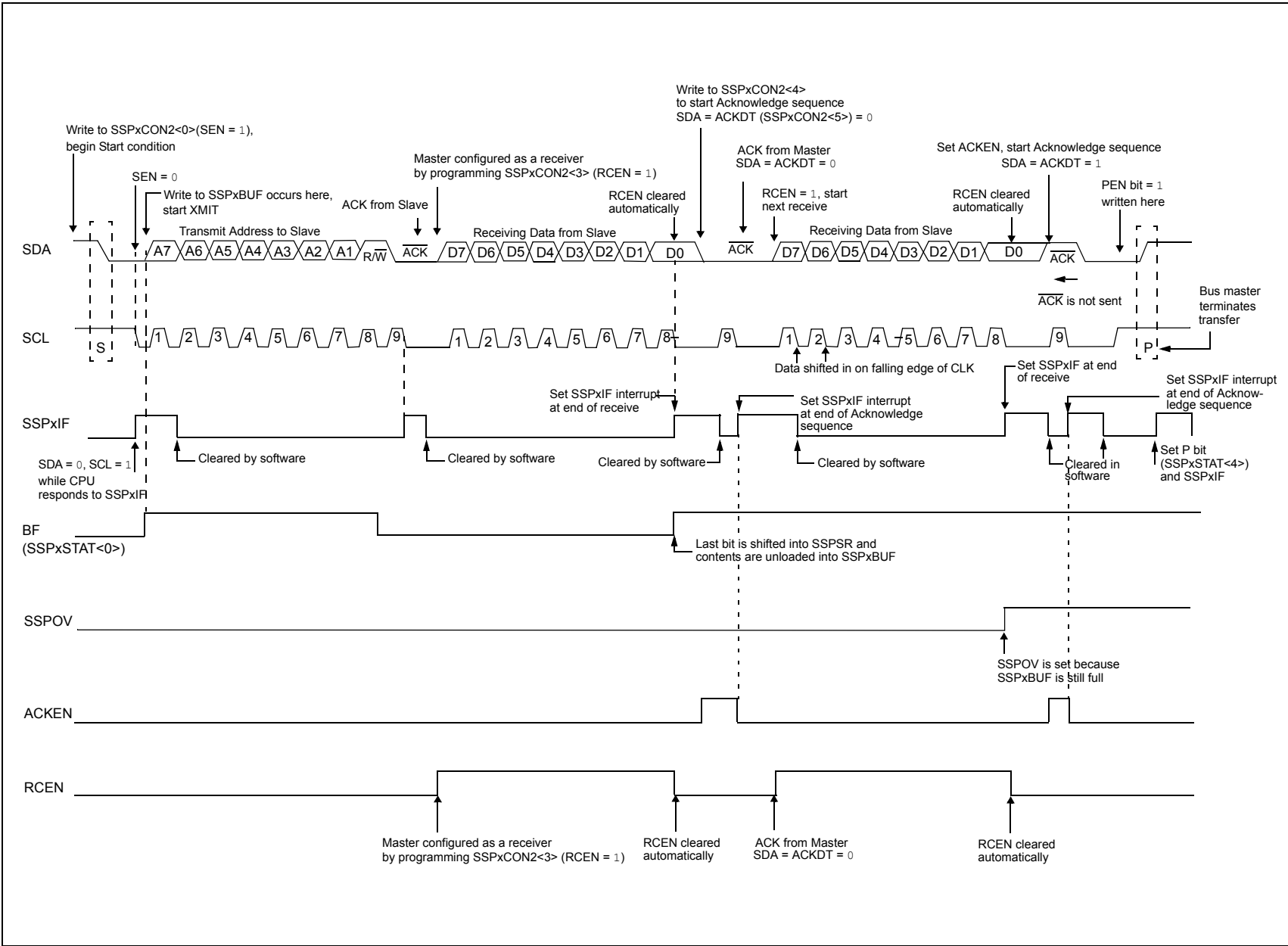


FIGURE 32-29: I<sup>2</sup>C MASTER MODE WAVEFORM (RECEPTION, 7-BIT ADDRESS)

## 32.6.8 ACKNOWLEDGE SEQUENCE TIMING

An Acknowledge sequence is enabled by setting the Acknowledge Sequence Enable bit, ACKEN, of the SSPxCON2 register. When this bit is set, the SCL pin is pulled low and the contents of the Acknowledge data bit are presented on the SDA pin. If the user wishes to generate an Acknowledge, then the ACKDT bit should be cleared. If not, the user should set the ACKDT bit before starting an Acknowledge sequence. The Baud Rate Generator then counts for one rollover period (TBRG) and the SCL pin is deasserted (pulled high). When the SCL pin is sampled high (clock arbitration), the Baud Rate Generator counts for TBRG. The SCL pin is then pulled low. Following this, the ACKEN bit is automatically cleared, the Baud Rate Generator is turned off and the MSSP module then goes into Idle mode (Figure 32-30).

### 32.6.8.1 WCOL Status Flag

If the user writes the SSPxBUF when an Acknowledge sequence is in progress, then the WCOL bit is set and the contents of the buffer are unchanged (the write does not occur).

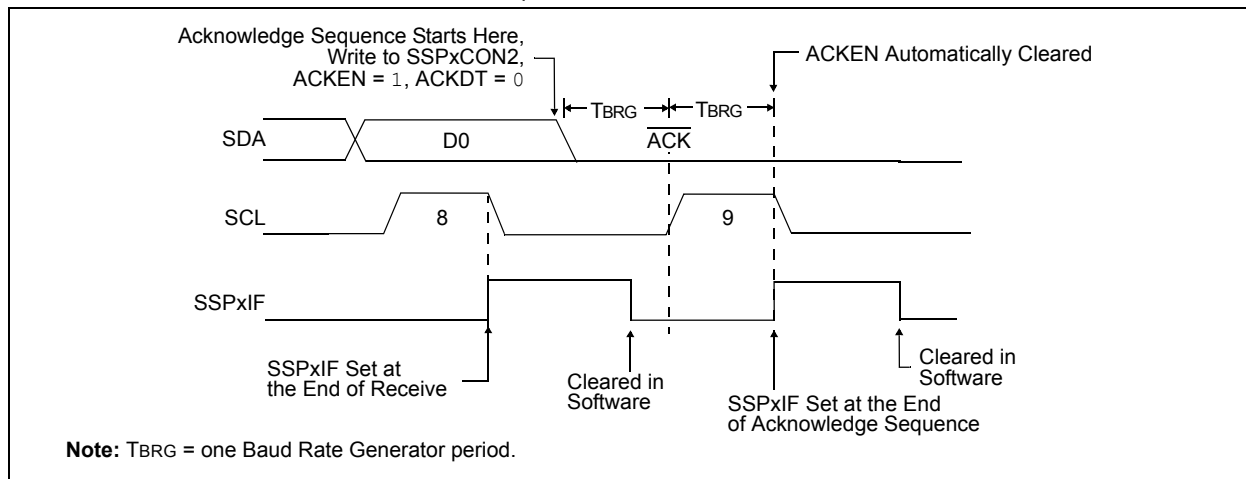
## 32.6.9 STOP CONDITION TIMING

A Stop bit is asserted on the SDA pin at the end of a receive/transmit by setting the Stop Sequence Enable bit, PEN, of the SSPxCON2 register. At the end of a receive/transmit, the SCL line is held low after the falling edge of the ninth clock. When the PEN bit is set, the master will assert the SDA line low. When the SDA line is sampled low, the Baud Rate Generator is reloaded and counts down to '0'. When the Baud Rate Generator times out, the SCL pin will be brought high and one TBRG (Baud Rate Generator rollover count) later, the SDA pin will be deasserted. When the SDA pin is sampled high while SCL is high, the P bit of the SSPxSTAT register is set. A TBRG later, the PEN bit is cleared and the SSPxIF bit is set (Figure 32-31).

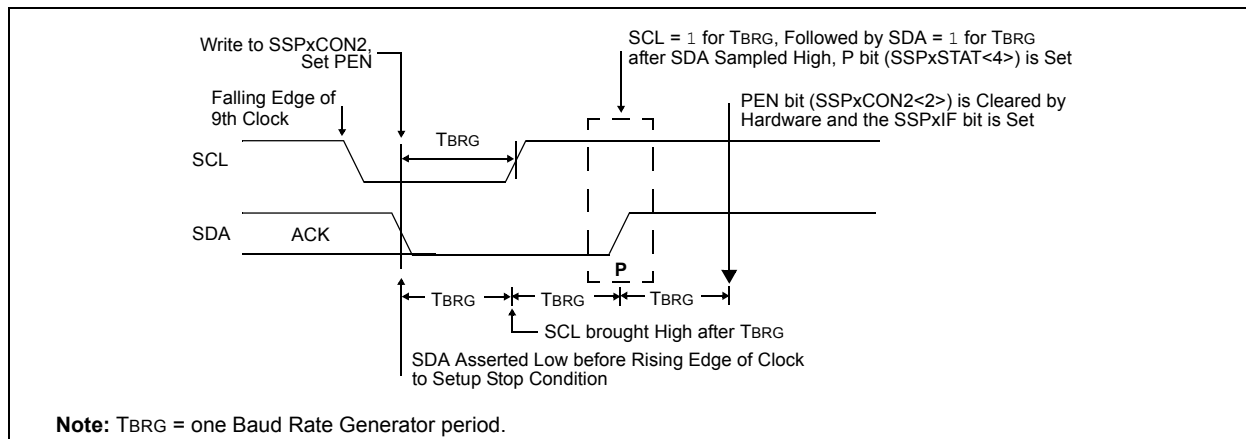
### 32.6.9.1 WCOL Status Flag

If the user writes the SSPxBUF when a Stop sequence is in progress, then the WCOL bit is set and the contents of the buffer are unchanged (the write does not occur).

**FIGURE 32-30: ACKNOWLEDGE SEQUENCE WAVEFORM**



**FIGURE 32-31: STOP CONDITION RECEIVE OR TRANSMIT MODE**



## 32.6.10 SLEEP OPERATION

While in Sleep mode, the I<sup>2</sup>C slave module can receive addresses or data and when an address match or complete byte transfer occurs, wake the processor from Sleep (if the MSSP interrupt is enabled).

## 32.6.11 EFFECTS OF A RESET

A Reset disables the MSSP module and terminates the current transfer.

## 32.6.12 MULTI-MASTER MODE

In Multi-Master mode, the interrupt generation on the detection of the Start and Stop conditions allows the determination of when the bus is free. The Stop (P) and Start (S) bits are cleared from a Reset or when the MSSP module is disabled. Control of the I<sup>2</sup>C bus may be taken when the P bit of the SSPxSTAT register is set, or the bus is Idle, with both the S and P bits clear. When the bus is busy, enabling the SSP interrupt will generate the interrupt when the Stop condition occurs.

In multi-master operation, the SDA line must be monitored for arbitration to see if the signal level is the expected output level. This check is performed by hardware with the result placed in the BCLIF bit.

The states where arbitration can be lost are:

- Address Transfer
- Data Transfer
- A Start Condition
- A Repeated Start Condition
- An Acknowledge Condition

## 32.6.13 MULTI-MASTER COMMUNICATION, BUS COLLISION AND BUS ARBITRATION

Multi-Master mode support is achieved by bus arbitration. When the master outputs address/data bits onto the SDA pin, arbitration takes place when the master outputs a '1' on SDA, by letting SDA float high and another master asserts a '0'. When the SCL pin floats high, data should be stable. If the expected data on SDA is a '1' and the data sampled on the SDA pin is '0', then a bus collision has taken place. The master will set the Bus Collision Interrupt Flag, BCLIF, and reset the I<sup>2</sup>C port to its Idle state (Figure 32-32).

If a transmit was in progress when the bus collision occurred, the transmission is halted, the BF flag is cleared, the SDA and SCL lines are deasserted and the SSPxBUF can be written to. When the user services the bus collision Interrupt Service Routine and if the I<sup>2</sup>C bus is free, the user can resume communication by asserting a Start condition.

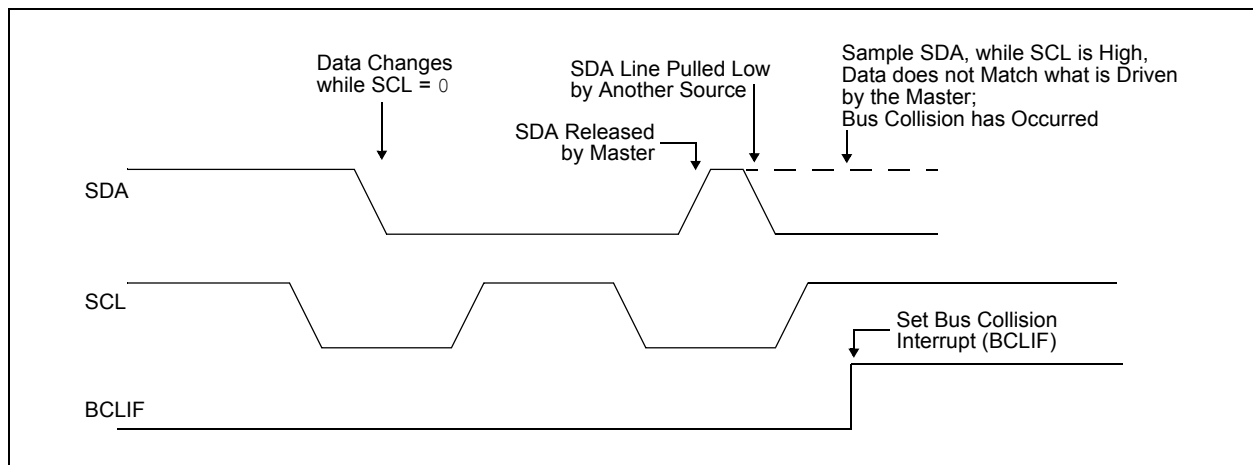
If a Start, Repeated Start, Stop or Acknowledge condition was in progress when the bus collision occurred, the condition is aborted, the SDA and SCL lines are deasserted and the respective control bits in the SSPxCON2 register are cleared. When the user services the bus collision Interrupt Service Routine and if the I<sup>2</sup>C bus is free, the user can resume communication by asserting a Start condition.

The master will continue to monitor the SDA and SCL pins. If a Stop condition occurs, the SSPxIF bit will be set.

A write to the SSPxBUF will start the transmission of data at the first data bit, regardless of where the transmitter left off when the bus collision occurred.

In Multi-Master mode, the interrupt generation on the detection of Start and Stop conditions allows the determination of when the bus is free. Control of the I<sup>2</sup>C bus can be taken when the P bit is set in the SSPxSTAT register, or the bus is Idle and the S and P bits are cleared.

**FIGURE 32-32: BUS COLLISION TIMING FOR TRANSMIT AND ACKNOWLEDGE**



## 32.6.13.1 Bus Collision During a Start Condition

During a Start condition, a bus collision occurs if:

- SDA or SCL is sampled low at the beginning of the Start condition (Figure 32-33).
- SCL is sampled low before SDA is asserted low (Figure 32-34).

During a Start condition, both the SDA and the SCL pins are monitored.

If the SDA pin is already low, or the SCL pin is already low, then all of the following occur:

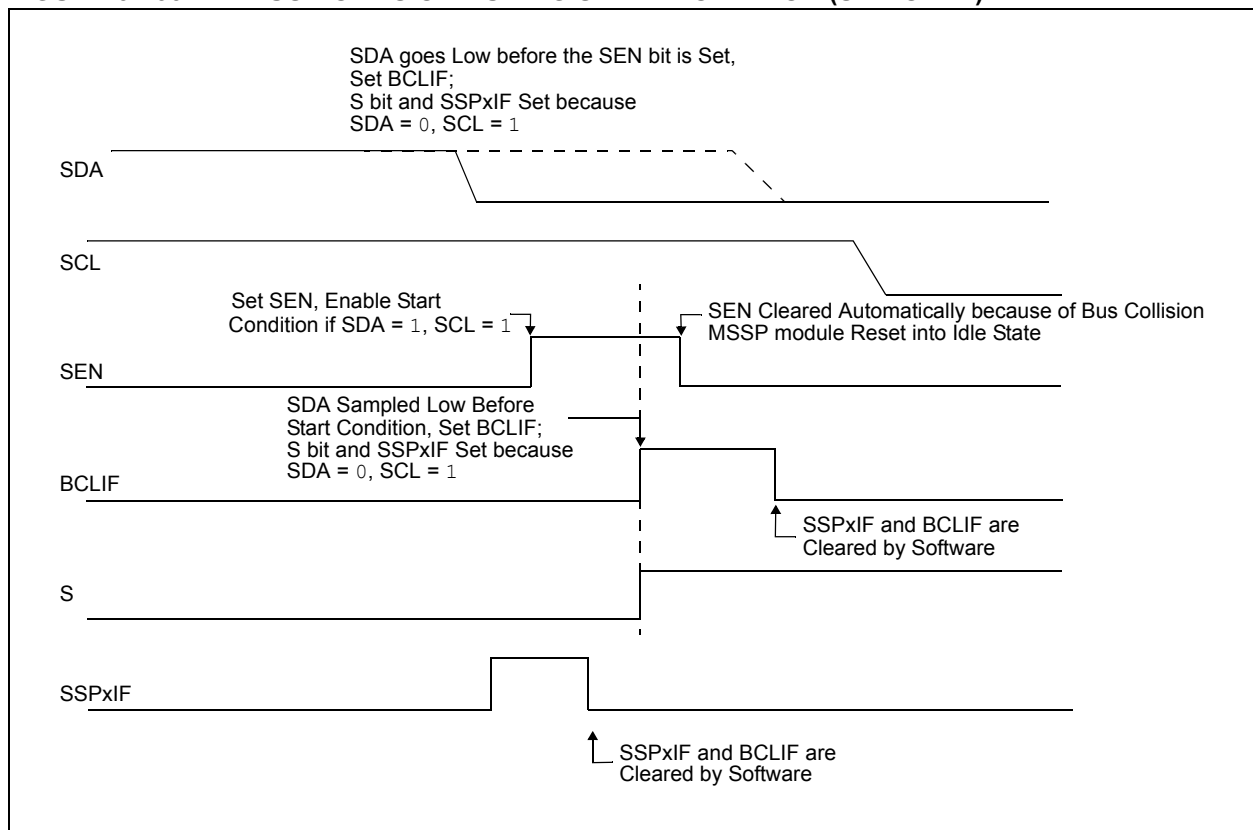
- The Start condition is aborted,
- The BCLIF flag is set and
- The MSSP module is reset to its Idle state (Figure 32-33).

The Start condition begins with the SDA and SCL pins deasserted. When the SDA pin is sampled high, the Baud Rate Generator is loaded and counts down. If the SCL pin is sampled low while SDA is high, a bus collision occurs because it is assumed that another master is attempting to drive a data '1' during the Start condition.

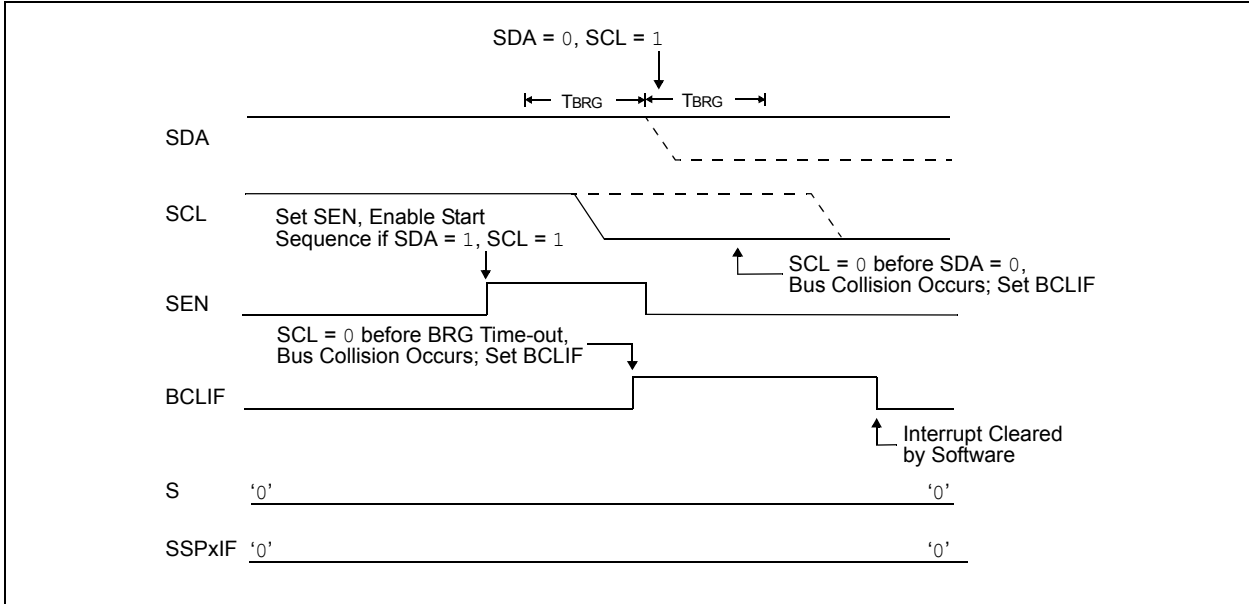
If the SDA pin is sampled low during this count, the BRG is reset and the SDA line is asserted early (Figure 32-35). If, however, a '1' is sampled on the SDA pin, the SDA pin is asserted low at the end of the BRG count. The Baud Rate Generator is then reloaded and counts down to zero; if the SCL pin is sampled as '0' during this time, a bus collision does not occur. At the end of the BRG count, the SCL pin is asserted low.

**Note:** The reason that bus collision is not a factor during a Start condition is that no two bus masters can assert a Start condition at the exact same time. Therefore, one master will always assert SDA before the other. This condition does not cause a bus collision because the two masters must be allowed to arbitrate the first address following the Start condition. If the address is the same, arbitration must be allowed to continue into the data portion, Repeated Start or Stop conditions.

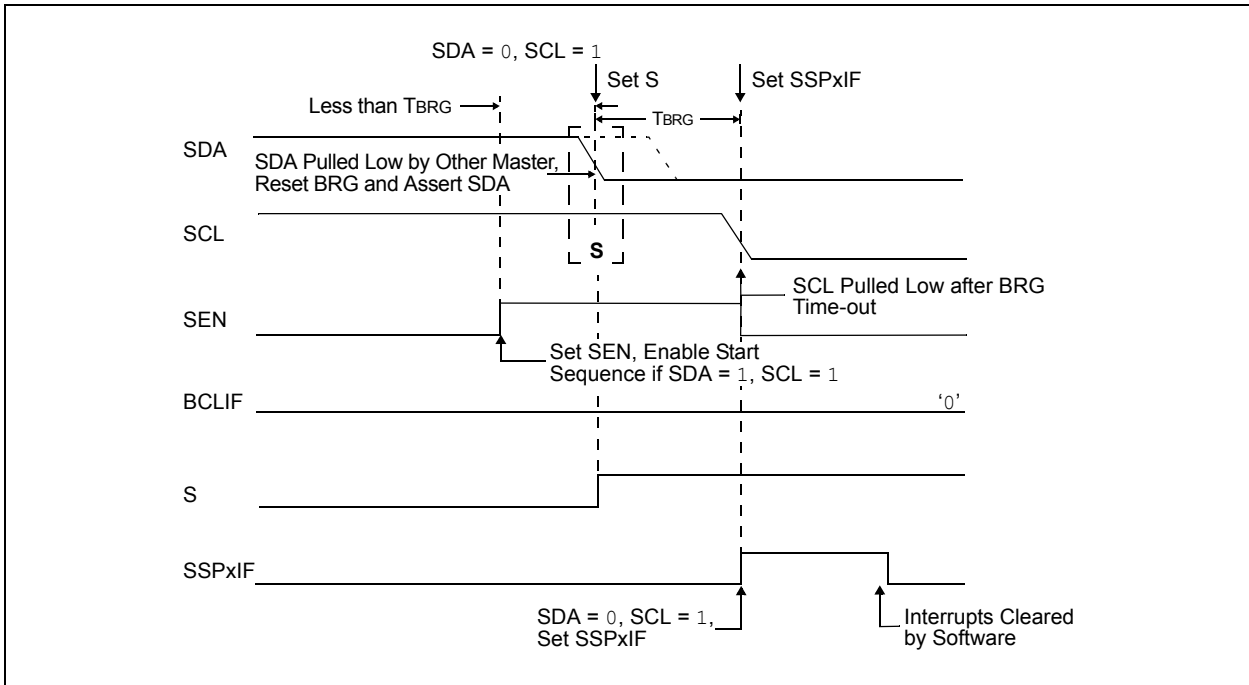
**FIGURE 32-33: BUS COLLISION DURING START CONDITION (SDA ONLY)**



**FIGURE 32-34: BUS COLLISION DURING START CONDITION (SCL = 0)**



**FIGURE 32-35: BRG RESET DUE TO SDA ARBITRATION DURING START CONDITION**



## 32.6.13.2 Bus Collision During a Repeated Start Condition

During a Repeated Start condition, a bus collision occurs if:

- A low level is sampled on SDA when SCL goes from low level to high level (Case 1).
- SCL goes low before SDA is asserted low, indicating that another master is attempting to transmit a data '1' (Case 2).

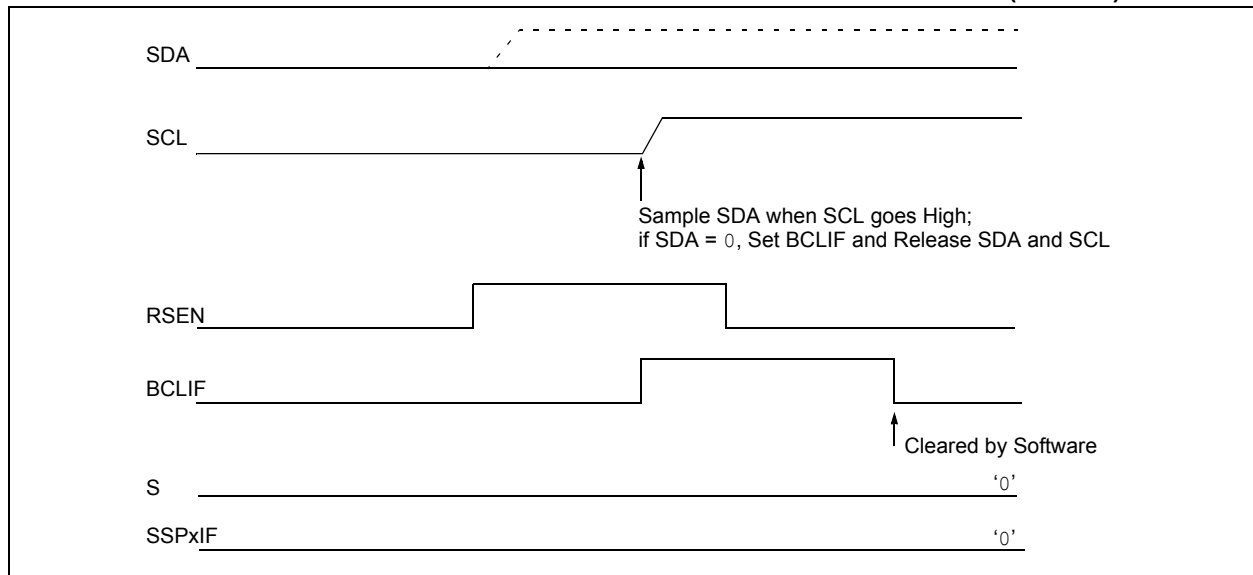
When the user releases SDA and the pin is allowed to float high, the BRG is loaded with SSPxADD and counts down to zero. The SCL pin is then deasserted and when sampled high, the SDA pin is sampled.

If SDA is low, a bus collision has occurred (i.e., another master is attempting to transmit a data '0', [Figure 32-36](#)). If SDA is sampled high, the BRG is reloaded and begins counting. If SDA goes from high-to-low before the BRG times out, no bus collision occurs because no two masters can assert SDA at exactly the same time.

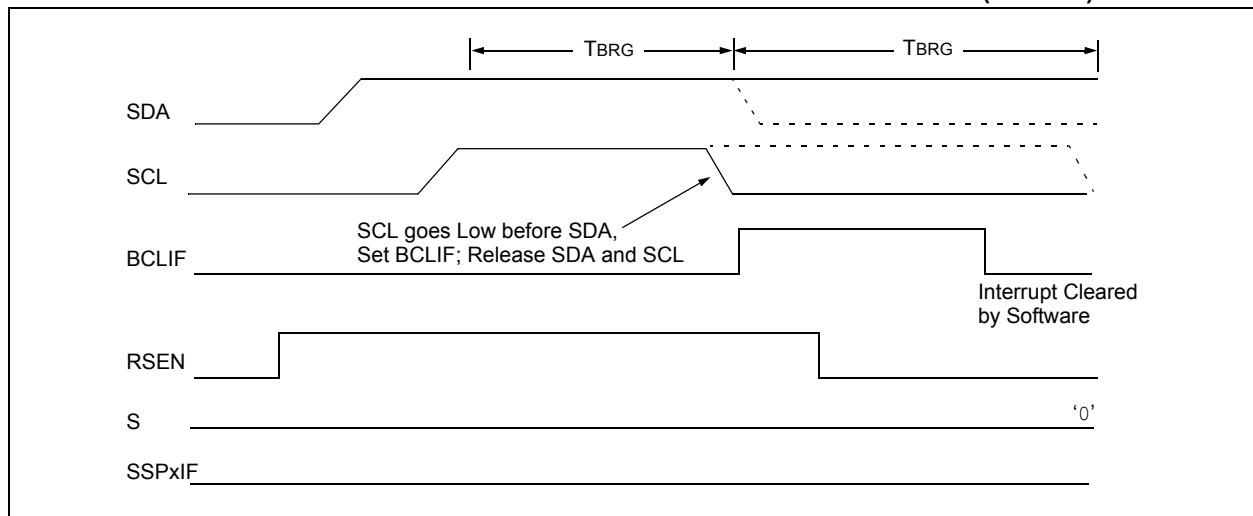
If SCL goes from high-to-low before the BRG times out and SDA has not already been asserted, a bus collision occurs. In this case, another master is attempting to transmit a data '1' during the Repeated Start condition, see [Figure 32-37](#).

If, at the end of the BRG time-out, both SCL and SDA are still high, the SDA pin is driven low and the BRG is reloaded and begins counting. At the end of the count, regardless of the status of the SCL pin, the SCL pin is driven low and the Repeated Start condition is complete.

**FIGURE 32-36: BUS COLLISION DURING A REPEATED START CONDITION (CASE 1)**



**FIGURE 32-37: BUS COLLISION DURING REPEATED START CONDITION (CASE 2)**





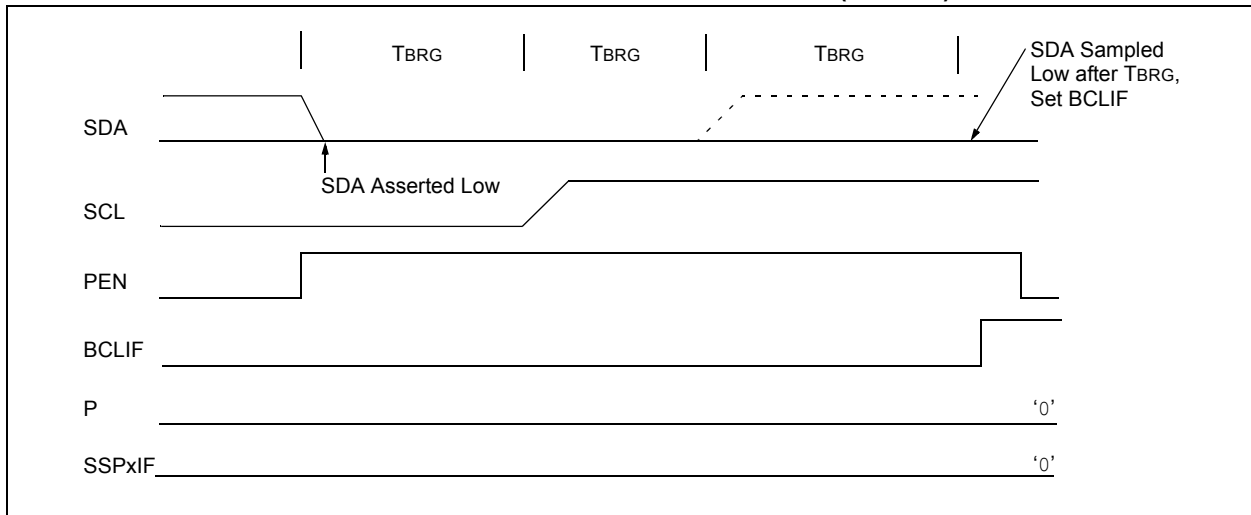
### 32.6.13.3 Bus Collision During a Stop Condition

Bus collision occurs during a Stop condition if:

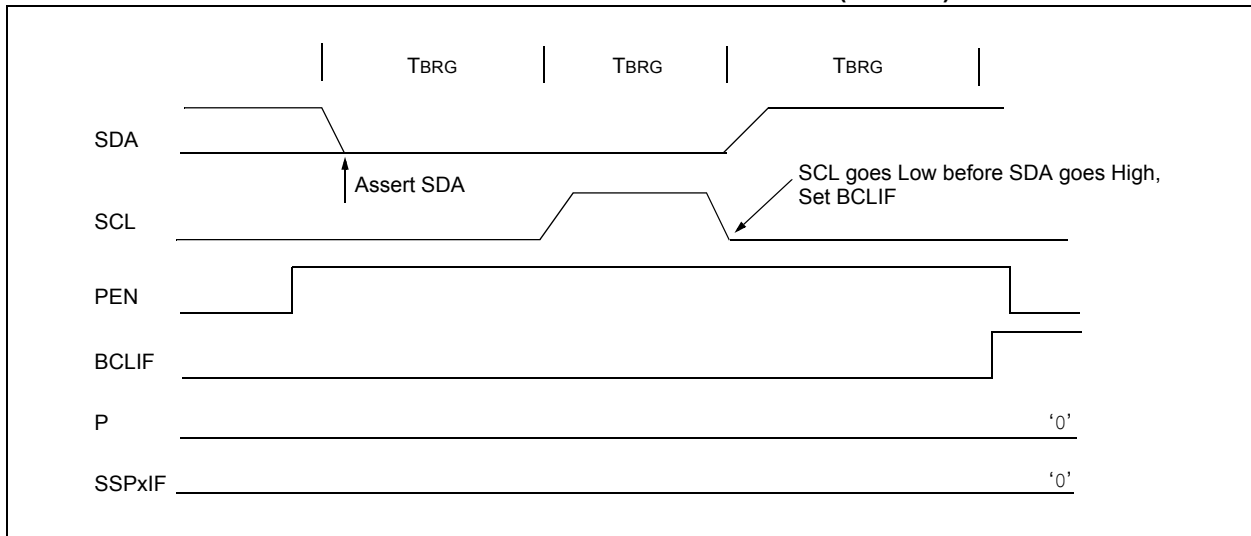
- After the SDA pin has been deasserted and allowed to float high, SDA is sampled low after the BRG has timed out (Case 1).
- After the SCL pin is deasserted, SCL is sampled low before SDA goes high (Case 2).

The Stop condition begins with SDA asserted low. When SDA is sampled low, the SCL pin is allowed to float. When the pin is sampled high (clock arbitration), the Baud Rate Generator is loaded with SSPxADD and counts down to zero. After the BRG times out, SDA is sampled. If SDA is sampled low, a bus collision has occurred. This is due to another master attempting to drive a data '0' (Figure 32-38). If the SCL pin is sampled low before SDA is allowed to float high, a bus collision occurs. This is another case of another master attempting to drive a data '0' (Figure 32-39).

**FIGURE 32-38: BUS COLLISION DURING A STOP CONDITION (CASE 1)**



**FIGURE 32-39: BUS COLLISION DURING A STOP CONDITION (CASE 2)**



# PIC16(L)F1764/5/8/9

**TABLE 32-3: SUMMARY OF REGISTERS ASSOCIATED WITH I<sup>2</sup>C OPERATION**

Name	Bit 7	Bit 6	Bit 5	Bit 4	Bit 3	Bit 2	Bit 1	Bit 0	Reset Values on Page:
ANSELA	—	—	—	ANSA4	—	ANSA<2:0>			139
ANSELB <sup>(1)</sup>	ANSB<7:4>				—	—	—	—	145
ANSELC	ANSC<7:6> <sup>(1)</sup>		—	—	ANSC<3:0>				150
INTCON	GIE	PEIE	TMR0IE	INTE	IOCIE	TMR0IF	INTF	IOCIF	101
PIE1	TMR1GIE	ADIE	RCIE	TXIE	SSP1IE	CCP1IE	TMR2IE	TMR1IE	102
PIE2	OSFIE	C2IE	C1IE	—	BCL1IE	C4IE <sup>(1)</sup>	C3IE <sup>(1)</sup>	CCP2IE <sup>(1)</sup>	103
PIR1	TMR1GIF	ADIF	RCIF	TXIF	SSP1IF	CCP1IF	TMR2IF	TMR1IF	106
PIR2	OSFIF	C2IF	C1IF	—	BCL1IF	C4IF <sup>(1)</sup>	C3IF <sup>(1)</sup>	CCP2IF <sup>(1)</sup>	107
RxyPPS	—	—	—	RxyPPS<4:0>				156	
SSPCLKPPS	—	—	—	SSPCLKPPS<4:0>				156, 158	
SSPDATPPS	—	—	—	SSPDATPPS<4:0>				156, 158	
SSPSSPPS	—	—	—	SSPSSPPS<4:0>				156, 158	
SSP1ADD	ADD<7:0>								434
SSP1BUF	Synchronous Serial Port Receive Buffer/Transmit Register								384*
SSP1CON1	WCOL	SSPOV	SSPEN	CKP	SSPM<3:0>				430
SSP1CON2	GCEN	ACKSTAT	ACKDT	ACKEN	RCEN	PEN	RSEN	SEN	432
SSP1CON3	ACKTIM	PCIE	SCIE	BOEN	SDAHT	SBCDE	AHEN	DHEN	433
SSP1MSK	MSK<7:0>								434
SSP1STAT	SMP	CKE	D $\bar{A}$	P	S	R $\bar{W}$	UA	BF	428
TRISA	—	—	TRISA<5:4>		— <sup>(2)</sup>	TRISA<2:0>			138
TRISB <sup>(1)</sup>	TRISB<7:4>								144
TRISC	TRISC<7:6> <sup>(1)</sup>		TRISC<5:0>						149

**Legend:** — = unimplemented location, read as '0'. Shaded cells are not used by the MSSP module in I<sup>2</sup>C mode.

\* Page provides register information.

**Note 1:** PIC16(L)F1768/9 only.

**2:** Unimplemented, read as '1'.

## 32.7 BAUD RATE GENERATOR

The MSSP module has a Baud Rate Generator available for clock generation in both I<sup>2</sup>C and SPI Master modes. The Baud Rate Generator (BRG) reload value is placed in the SSPxADD register (Register 32-6). When a write occurs to SSPxBUF, the Baud Rate Generator will automatically begin counting down.

Once the given operation is complete, the internal clock will automatically stop counting and the clock pin will remain in its last state.

An internal signal “Reload” in Figure 32-40 triggers the value from SSPxADD to be loaded into the BRG counter. This occurs twice for each oscillation of the

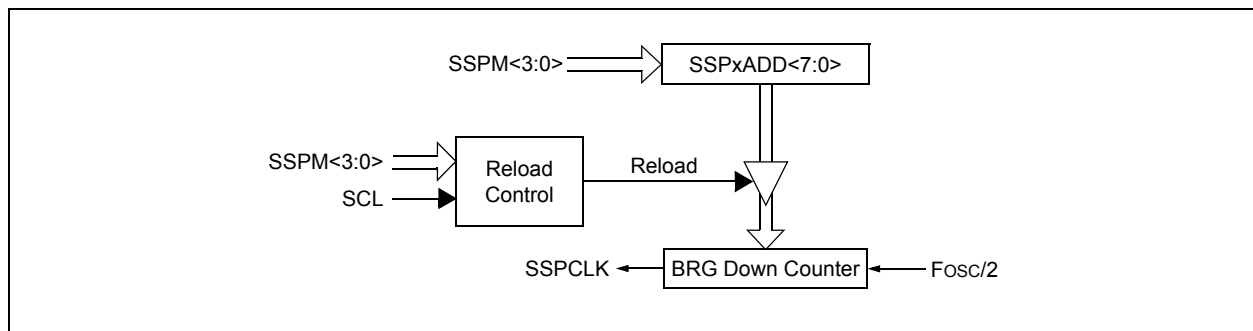
module clock line. The logic dictating when the reload signal is asserted depends on the mode the MSSP is being operated in.

Table 32-4 demonstrates clock rates based on instruction cycles and the BRG value loaded into SSPxADD.

**EQUATION 32-1:**

$$F_{CLOCK} = \frac{F_{OSC}}{(SSPxADD + 1)(4)}$$

**FIGURE 32-40: BAUD RATE GENERATOR BLOCK DIAGRAM**



**Note:** Values of 0x00, 0x01 and 0x02 are not valid for SSPxADD when used as a Baud Rate Generator for I<sup>2</sup>C; this is an implementation limitation.

**TABLE 32-4: MSSP CLOCK RATE w/BRG**

Fosc	Fcy	BRG Value	F <sub>CLOCK</sub> (2 Rollovers of BRG)
32 MHz	8 MHz	13h	400 kHz
32 MHz	8 MHz	19h	308 kHz
32 MHz	8 MHz	4Fh	100 kHz
16 MHz	4 MHz	09h	400 kHz
16 MHz	4 MHz	0Ch	308 kHz
16 MHz	4 MHz	27h	100 kHz
4 MHz	1 MHz	09h	100 kHz

**Note:** Refer to the I/O port electrical specifications in Table 36-10 and Figure 36-7 to ensure the system is designed to support I/O timing requirements.

## 32.8 Register Definitions: MSSP Control

### REGISTER 32-1: SSP1STAT: MSSP STATUS REGISTER

R/W-0/0	R/W-0/0	R-0/0	R-0/0	R-0/0	R-0/0	R-0/0	R-0/0
SMP	CKE	D/A	P	S	R/W	UA	BF
bit 7							bit 0

#### Legend:

R = Readable bit	W = Writable bit	
u = Bit is unchanged	x = Bit is unknown	U = Unimplemented bit, read as '0'
'1' = Bit is set	'0' = Bit is cleared	-n/n = Value at POR and BOR/Value at all other Resets

- bit 7      **SMP:** SPI Data Input Sample bit  
SPI Master mode:  
 1 = Input data sampled at end of data output time  
 0 = Input data sampled at middle of data output time  
SPI Slave mode:  
 SMP must be cleared when SPI is used in Slave mode.  
In I<sup>2</sup>C Master or Slave mode:  
 1 = Slew rate control is disabled for Standard Speed mode (100 kHz and 1 MHz)  
 0 = Slew rate control is enabled for High-Speed mode (400 kHz)
- bit 6      **CKE:** SPI Clock Edge Select bit (SPI mode only)  
In SPI Master or Slave mode:  
 1 = Transmit occurs on transition from active to Idle clock state  
 0 = Transmit occurs on transition from Idle to active clock state  
In I<sup>2</sup>C mode only:  
 1 = Enables input logic so that thresholds are compliant with SMBus specification  
 0 = Disables SMBus specific inputs
- bit 5      **D/A:** Data/Address bit (I<sup>2</sup>C mode only)  
 1 = Indicates that the last byte received or transmitted was data  
 0 = Indicates that the last byte received or transmitted was address
- bit 4      **P:** Stop bit (I<sup>2</sup>C mode only; this bit is cleared when the MSSP module is disabled, SSPEN is cleared)  
 1 = Indicates that a Stop bit has been detected last (this bit is '0' on Reset)  
 0 = Stop bit was not detected last
- bit 3      **S:** Start bit (I<sup>2</sup>C mode only; this bit is cleared when the MSSP module is disabled, SSPEN is cleared)  
 1 = Indicates that a Start bit has been detected last (this bit is '0' on Reset)  
 0 = Start bit was not detected last
- bit 2      **R/W:** Read/Write bit information (I<sup>2</sup>C mode only)  
 This bit holds the R/W bit information following the last address match. This bit is only valid from the address match to the next Start bit, Stop bit or not ACK bit.  
In I<sup>2</sup>C Slave mode:  
 1 = Read  
 0 = Write  
In I<sup>2</sup>C Master mode:  
 1 = Transmit is in progress  
 0 = Transmit is not in progress  
 ORing this bit with SEN, RSEN, PEN, RCEN or ACKEN will indicate if the MSSP is in Idle mode.
- bit 1      **UA:** Update Address bit (10-bit I<sup>2</sup>C mode only)  
 1 = Indicates that the user needs to update the address in the SSPxADD register  
 0 = Address does not need to be updated

## REGISTER 32-1: SSP1STAT: MSSP STATUS REGISTER (CONTINUED)

bit 0

**BF:** Buffer Full Status bit

Receive (SPI and I<sup>2</sup>C modes):

1 = Receive is complete, SSPxBUF is full

0 = Receive is not complete, SSPxBUF is empty

Transmit (I<sup>2</sup>C mode only):

1 = Data transmit is in progress (does not include the ACK and Stop bits), SSPxBUF is full

0 = Data transmit is complete (does not include the ACK and Stop bits), SSPxBUF is empty

## REGISTER 32-2: SSP1CON1: MSSP CONTROL REGISTER 1

R/C/HS-0/0	R/C/HS-0/0	R/W-0/0	R/W-0/0	R/W-0/0	R/W-0/0	R/W-0/0	R/W-0/0
WCOL	SSPOV <sup>(1)</sup>	SSPEN	CKP	SSPM<3:0>			
bit 7							bit 0

### Legend:

R = Readable bit	W = Writable bit	HS = Hardware Settable bit	C = Clearable bit
u = Bit is unchanged	x = Bit is unknown	U = Unimplemented bit, read as '0'	
'1' = Bit is set	'0' = Bit is cleared	-n/n = Value at POR and BOR/Value at all other Resets	

bit 7 **WCOL:** Write Collision Detect bit

#### Master mode:

1 = A write to the SSPxBUF register was attempted while the I<sup>2</sup>C conditions were not valid for a transmission to be started

0 = No collision

#### Slave mode:

1 = The SSPxBUF register is written while it is still transmitting the previous word (must be cleared in software)

0 = No collision

bit 6 **SSPOV:** Receive Overflow Indicator bit<sup>(1)</sup>

#### In SPI mode:

1 = A new byte is received while the SSPxBUF register is still holding the previous data. In case of overflow, the data in SSPSR is lost. Overflow can only occur in Slave mode. In Slave mode, the user must read the SSPxBUF, even if only transmitting data, to avoid setting overflow. In Master mode, the overflow bit is not set since each new reception (and transmission) is initiated by writing to the SSPxBUF register (must be cleared in software).

0 = No overflow

#### In I<sup>2</sup>C mode:

1 = A byte is received while the SSPxBUF register is still holding the previous byte. SSPOV is a "don't care" in Transmit mode (must be cleared in software).

0 = No overflow

bit 5 **SSPEN:** Synchronous Serial Port Enable bit

In both modes, when enabled, these pins must be properly configured as input or output.

#### In SPI mode:

1 = Enables serial port and configures SCK, SDO, SDI and  $\overline{SS}$  as the source of the serial port pins<sup>(2)</sup>

0 = Disables serial port and configures these pins as I/O port pins

#### In I<sup>2</sup>C mode:

1 = Enables the serial port and configures the SDA and SCL pins as the source of the serial port pins<sup>(3)</sup>

0 = Disables serial port and configures these pins as I/O port pins

- Note 1:** In Master mode, the overflow bit is not set since each new reception (and transmission) is initiated by writing to the SSPxBUF register.
- 2:** When enabled, these pins must be properly configured as input or output. Use SSPSSPPS, SSPCLKPPS, SSPDATPPS and RxyPPS to select the pins.
- 3:** When enabled, the SDA and SCL pins must be configured as inputs. Use SSPCLKPPS, SSPDATPPS and RxyPPS to select the pins.
- 4:** SSPxADD values of 0, 1 or 2 are not supported for I<sup>2</sup>C mode.
- 5:** SSPxADD value of 0 is not supported; use SSPM<3:0> = 0000 instead.

## REGISTER 32-2: SSP1CON1: MSSP CONTROL REGISTER 1 (CONTINUED)

bit 4 **CKP:** Clock Polarity Select bit

In SPI mode:

1 = Idle state for clock is a high level

0 = Idle state for clock is a low level

In I<sup>2</sup>C Slave mode:

SCL release control.

1 = Enables clock

0 = Holds clock low (clock stretch), used to ensure data setup time

In I<sup>2</sup>C Master mode:

Unused in this mode.

bit 3-0 **SSPM<3:0>:** Synchronous Serial Port Mode Select bits

1111 = I<sup>2</sup>C Slave mode, 10-bit address with Start and Stop bit interrupts enabled

1110 = I<sup>2</sup>C Slave mode, 7-bit address with Start and Stop bit interrupts enabled

1101 = Reserved

1100 = Reserved

1011 = I<sup>2</sup>C Firmware Controlled Master mode (slave Idle)

1010 = SPI Master mode, clock =  $F_{osc}/(4 * (SSP1ADD + 1))^{(5)}$

1001 = Reserved

1000 = I<sup>2</sup>C Master mode, clock =  $F_{osc}/(4 * (SSP1ADD + 1))^{(4)}$

0111 = I<sup>2</sup>C Slave mode, 10-bit address

0110 = I<sup>2</sup>C Slave mode, 7-bit address

0101 = SPI Slave mode, clock = SCK pin,  $\overline{SS}$  pin control is disabled,  $\overline{SS}$  can be used as I/O pin

0100 = SPI Slave mode, clock = SCK pin,  $\overline{SS}$  pin control is enabled

0011 = SPI Master mode, clock =  $T2\_match/2$

0010 = SPI Master mode, clock =  $F_{osc}/64$

0001 = SPI Master mode, clock =  $F_{osc}/16$

0000 = SPI Master mode, clock =  $F_{osc}/4$

- Note 1:** In Master mode, the overflow bit is not set since each new reception (and transmission) is initiated by writing to the SSPxBUF register.
- 2:** When enabled, these pins must be properly configured as input or output. Use SSPSSPPS, SSPCLKPPS, SSPDATPPS and RxyPPS to select the pins.
- 3:** When enabled, the SDA and SCL pins must be configured as inputs. Use SSPCLKPPS, SSPDATPPS and RxyPPS to select the pins.
- 4:** SSPxADD values of 0, 1 or 2 are not supported for I<sup>2</sup>C mode.
- 5:** SSPxADD value of 0 is not supported; use SSPM<3:0> = 0000 instead.

# PIC16(L)F1764/5/8/9

## REGISTER 32-3: SSP1CON2: MSSP CONTROL REGISTER 2<sup>(1)</sup>

R/W-0/0	R-0/0	R/W-0/0	R/S/HS-0/0	R/S/HS-0/0	R/S/HS-0/0	R/S/HS-0/0	R/W/HS-0/0
GCEN	ACKSTAT	ACKDT	ACKEN	RCEN	PEN	RSEN	SEN
bit 7							bit 0

### Legend:

R = Readable bit	W = Writable bit	HS = Hardware Settable bit	S = Settable bit
u = Bit is unchanged	x = Bit is unknown	U = Unimplemented bit, read as '0'	
'1' = Bit is set	'0' = Bit is cleared	-n/n = Value at POR and BOR/Value at all other Resets	

- bit 7      **GCEN:** General Call Enable bit (in I<sup>2</sup>C Slave mode only)  
 1 = Enables interrupt when a general call address (0x00 or 00h) is received in the SSPSR  
 0 = General call address disabled
- bit 6      **ACKSTAT:** Acknowledge Status bit (in I<sup>2</sup>C mode only)  
 1 = Acknowledge was not received  
 0 = Acknowledge was received
- bit 5      **ACKDT:** Acknowledge Data bit (in I<sup>2</sup>C mode only)  
In Receive mode:  
 Value transmitted when the user initiates an Acknowledge sequence at the end of a receive.  
 1 = Not Acknowledge  
 0 = Acknowledge
- bit 4      **ACKEN:** Acknowledge Sequence Enable bit (in I<sup>2</sup>C Master mode only)  
In Master Receive mode:  
 1 = Initiate Acknowledge sequence on SDA and SCL pins, and transmit ACKDT data bit; automatically cleared by hardware  
 0 = Acknowledge sequence is Idle
- bit 3      **RCEN:** Receive Enable bit (in I<sup>2</sup>C Master mode only)  
 1 = Enables Receive mode for I<sup>2</sup>C  
 0 = Receive is Idle
- bit 2      **PEN:** Stop Condition Enable bit (in I<sup>2</sup>C Master mode only)  
SCKMSSP Release Control:  
 1 = Initiates Stop condition on SDA and SCL pins; automatically cleared by hardware  
 0 = Stop condition is Idle
- bit 1      **RSEN:** Repeated Start Condition Enable bit (in I<sup>2</sup>C Master mode only)  
 1 = Initiates Repeated Start condition on SDA and SCL pins; automatically cleared by hardware  
 0 = Repeated Start condition is Idle
- bit 0      **SEN:** Start Condition Enable/Stretch Enable bit  
In Master mode:  
 1 = Initiates Start condition on SDA and SCL pins; automatically cleared by hardware  
 0 = Start condition is Idle  
In Slave mode:  
 1 = Clock stretching is enabled for both slave transmit and slave receive (stretch enabled)  
 0 = Clock stretching is disabled

**Note 1:** For bits ACKEN, RCEN, PEN, RSEN, SEN: If the I<sup>2</sup>C module is not in Idle mode, this bit may not be set (no pooling) and the SSPxBUF may not be written (or writes to the SSPxBUF are disabled).



# PIC16(L)F1764/5/8/9

## REGISTER 32-4: SSP1CON3: MSSP CONTROL REGISTER 3

R-0/0	R/W-0/0	R/W-0/0	R/W-0/0	R/W-0/0	R/W-0/0	R/W-0/0	R/W-0/0
ACKTIM <sup>(3)</sup>	PCIE	SCIE	BOEN	SDAHT	SBCDE	AHEN	DHEN
bit 7							bit 0

### Legend:

R = Readable bit	W = Writable bit	
u = Bit is unchanged	x = Bit is unknown	U = Unimplemented bit, read as '0'
'1' = Bit is set	'0' = Bit is cleared	-n/n = Value at POR and BOR/Value at all other Resets

- bit 7      **ACKTIM:** Acknowledge Time Status bit (I<sup>2</sup>C slave modes only)<sup>(3)</sup>  
 1 = Indicates the I<sup>2</sup>C bus is in an Acknowledge sequence, set on eighth falling edge of SCL clock  
 0 = Not an Acknowledge sequence, cleared on 9<sup>th</sup> rising edge of SCL clock
- bit 6      **PCIE:** Stop Condition Interrupt Enable bit (I<sup>2</sup>C slave modes only)  
 1 = Enables interrupt on detection of Stop condition  
 0 = Stop detection interrupts are disabled<sup>(2)</sup>
- bit 5      **SCIE:** Start Condition Interrupt Enable bit (I<sup>2</sup>C slave modes only)  
 1 = Enables interrupt on detection of Start or Restart conditions  
 0 = Start detection interrupts are disabled<sup>(2)</sup>
- bit 4      **BOEN:** Buffer Overwrite Enable bit  
In SPI Slave mode:<sup>(1)</sup>  
 1 = SSPxBUF updates every time that a new data byte is shifted in, ignoring the BF bit  
 0 = If new byte is received with BF bit of the SSPxSTAT register already set, the SSPOV bit of the SSPxCON1 register is set and the buffer is not updated  
In I<sup>2</sup>C Master mode and SPI Master mode:  
 This bit is ignored.  
In I<sup>2</sup>C Slave mode:  
 1 = SSPxBUF is updated and ACK is generated for a received address/data byte, ignoring the state of the SSPOV bit only if the BF bit = 0  
 0 = SSPxBUF is only updated when SSPOV is clear
- bit 3      **SDAHT:** SDA Hold Time Selection bit (I<sup>2</sup>C mode only)  
 1 = Minimum of 300 ns hold time on SDA after the falling edge of SCL  
 0 = Minimum of 100 ns hold time on SDA after the falling edge of SCL
- bit 2      **SBCDE:** Slave Mode Bus Collision Detect Enable bit (I<sup>2</sup>C Slave mode only)  
 If, on the rising edge of SCL, SDA is sampled low when the module is outputting a high state, the BCL1IF bit of the PIR2 register is set and the bus goes Idle  
 1 = Enables slave bus collision interrupts  
 0 = Slave bus collision interrupts are disabled
- bit 1      **AHEN:** Address Hold Enable bit (I<sup>2</sup>C Slave mode only)  
 1 = Following the eighth falling edge of SCL for a matching received address byte; CKP bit of the SSPxCON1 register will be cleared and the SCL will be held low  
 0 = Address holding is disabled
- bit 0      **DHEN:** Data Hold Enable bit (I<sup>2</sup>C Slave mode only)  
 1 = Following the eighth falling edge of SCL for a received data byte; slave hardware clears the CKP bit of the SSPxCON1 register and SCL is held low  
 0 = Data holding is disabled

- Note 1:** For daisy-chained SPI operation; allows the user to ignore all but the last received byte. SSPOV is still set when a new byte is received and BF = 1, but hardware continues to write the most recent byte to SSP1BUF.
- 2:** This bit has no effect in Slave modes in which Start and Stop condition detection is explicitly listed as enabled.
- 3:** The ACKTIM status bit is only active when the AHEN bit or DHEN bit is set.

## REGISTER 32-5: SSP1MSK: MSSP MASK REGISTER

R/W-1/1	R/W-1/1	R/W-1/1	R/W-1/1	R/W-1/1	R/W-1/1	R/W-1/1	R/W-1/1
MSK<7:0>							
bit 7							bit 0

### Legend:

R = Readable bit	W = Writable bit	
u = Bit is unchanged	x = Bit is unknown	U = Unimplemented bit, read as '0'
'1' = Bit is set	'0' = Bit is cleared	-n/n = Value at POR and BOR/Value at all other Resets

bit 7-1      **MSK<7:1>**: Mask bits  
 1 = The received address bit n is compared to SSPxADD<n> to detect I<sup>2</sup>C address match  
 0 = The received address bit n is not used to detect I<sup>2</sup>C address match

bit 0      **MSK0**: Mask for I<sup>2</sup>C Slave mode bit (10-Bit Address)  
10-Bit Address, SSPM<3:0> = 0111 or 1111:  
 1 = The received address bit 0 is compared to SSPxADD<0> to detect I<sup>2</sup>C address match  
 0 = The received address bit 0 is not used to detect I<sup>2</sup>C address match  
 I<sup>2</sup>C Slave mode, 7-Bit Address, the bit is ignored.

## REGISTER 32-6: SSP1ADD: MSSP ADDRESS AND BAUD RATE REGISTER (I<sup>2</sup>C MODE)

R/W-0/0	R/W-0/0	R/W-0/0	R/W-0/0	R/W-0/0	R/W-0/0	R/W-0/0	R/W-0/0
ADD<7:0>							
bit 7							bit 0

### Legend:

R = Readable bit	W = Writable bit	
u = Bit is unchanged	x = Bit is unknown	U = Unimplemented bit, read as '0'
'1' = Bit is set	'0' = Bit is cleared	-n/n = Value at POR and BOR/Value at all other Resets

**Master mode:**

bit 7-0      **ADD<7:0>**: Baud Rate Clock Divider bits  
 SCL pin clock period = ((ADD<7:0> + 1) \* 4)/Fosc.

**10-Bit Slave mode – Most Significant Address Byte:**

bit 7-3      **ADD<7:3>**: MSSP Address bits  
**Not Used:** Unused for Most Significant Address Byte. Bit state of this register is a “don't care”. Bit pattern sent by master is fixed by I<sup>2</sup>C specification and must be equal to '11110'. However, those bits are compared by hardware and are not affected by the value in this register.

bit 2-1      **ADD<2:1>**: Two Most Significant 10-Bit Address bits

bit 0      **ADD0**: MSSP Address bit  
**Not Used:** Unused in this mode. Bit state is a “don't care”.

**10-Bit Slave mode – Least Significant Address Byte:**

bit 7-0      **ADD<7:0>**: Eight Least Significant 10-Bit Address bits

**7-Bit Slave mode:**

bit 7-1      **ADD<7:1>**: MSSP 7-Bit Address bits

bit 0      **ADD0**: MSSP Address bit  
**Not Used:** Unused in this mode. Bit state is a “don't care”.

## 33.0 ENHANCED UNIVERSAL SYNCHRONOUS ASYNCHRONOUS RECEIVER TRANSMITTER (EUSART)

The Enhanced Universal Synchronous Asynchronous Receiver Transmitter (EUSART) module is a serial I/O communications peripheral. It contains all the clock generators, shift registers and data buffers necessary to perform an input or output serial data transfer independent of device program execution. The EUSART, also known as a Serial Communications Interface (SCI), can be configured as a full-duplex asynchronous system or half-duplex synchronous system. Full-Duplex mode is useful for communications with peripheral systems, such as CRT terminals and personal computers. Half-Duplex Synchronous mode is intended for communications with peripheral devices, such as A/D or D/A integrated circuits, serial EEPROMs or other microcontrollers. These devices typically do not have internal clocks for baud rate generation and require the external clock signal provided by a master synchronous device.

The EUSART module includes the following capabilities:

- Full-duplex asynchronous transmit and receive
- Two-character input buffer
- One-character output buffer
- Programmable 8-bit or 9-bit character length
- Address detection in 9-bit mode
- Input buffer overrun error detection
- Received character framing error detection
- Half-duplex synchronous master
- Half-duplex synchronous slave
- Programmable clock polarity in Synchronous modes
- Sleep operation

The EUSART module implements the following additional features, making it ideally suited for use in Local Interconnect Network (LIN) bus systems:

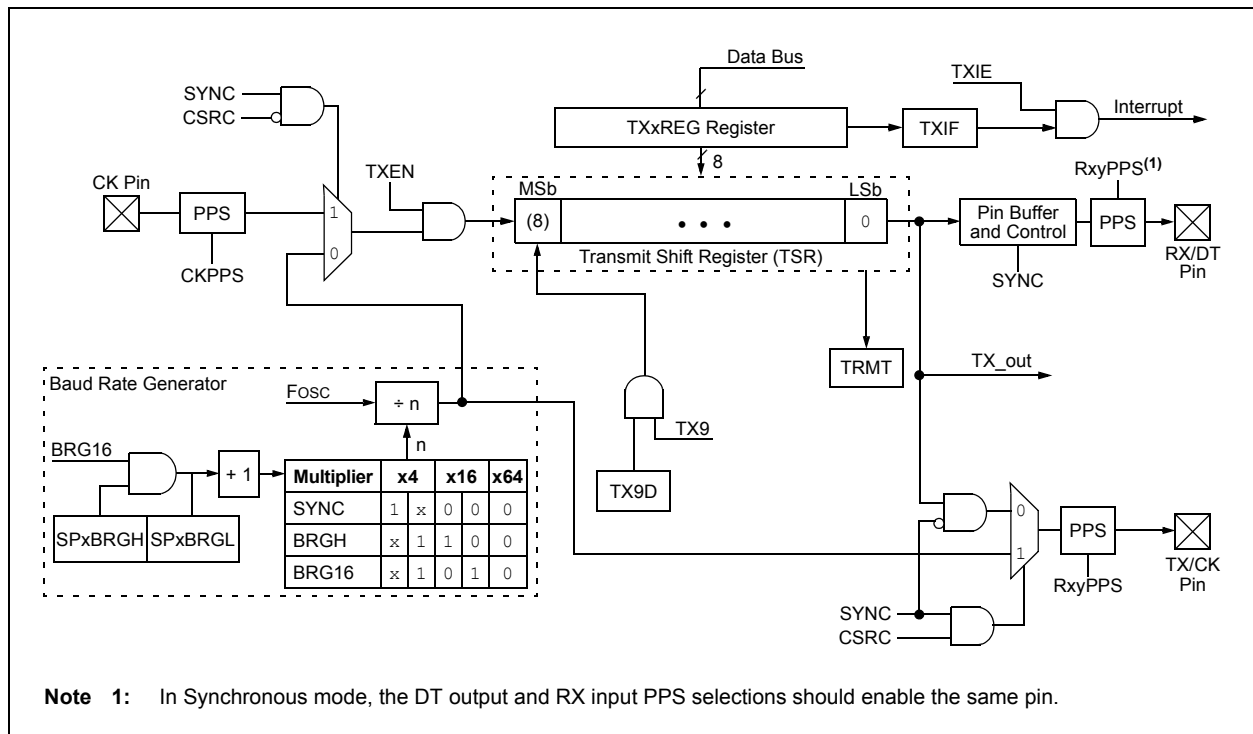
- Automatic detection and calibration of the baud rate
- Wake-up on Break reception
- 13-bit Break character transmit

Block diagrams of the EUSART transmitter and receiver are shown in [Figure 33-1](#) and [Figure 33-2](#).

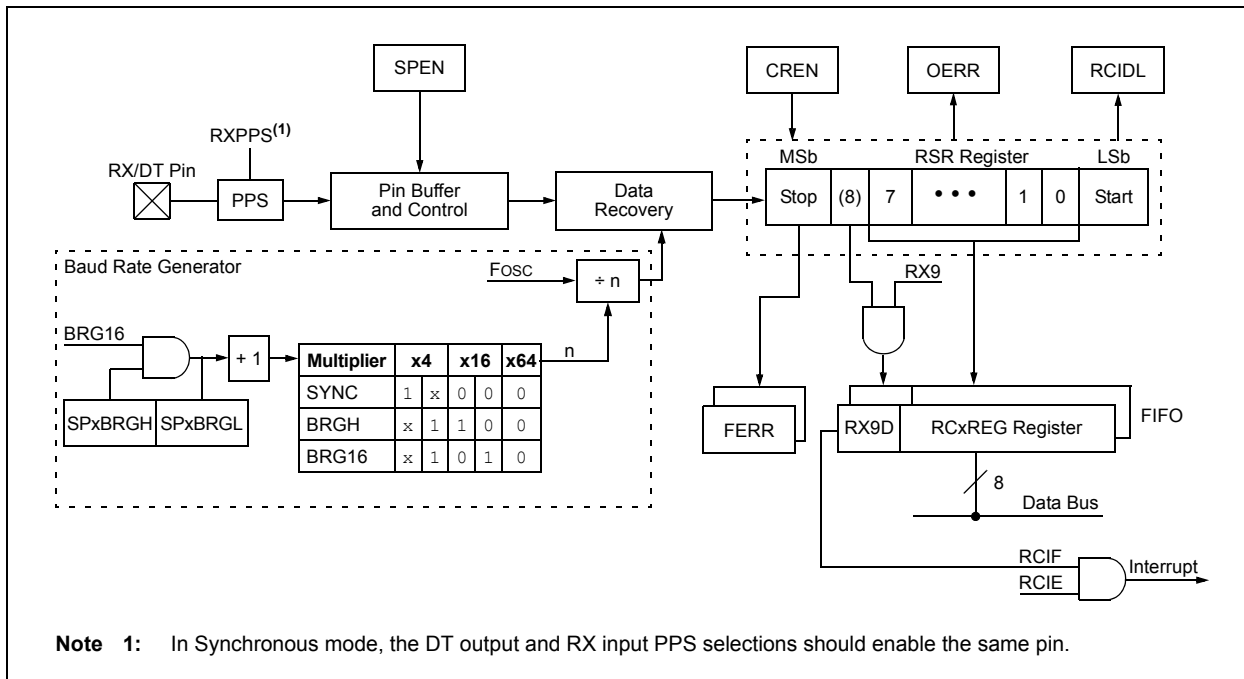
The EUSART transmit output (TX\_out) is available to the TX/CK pin and internally to the following peripherals:

- Configurable Logic Cell (CLC)
- Data Signal Modulator (DSM)

**FIGURE 33-1: EUSART TRANSMIT BLOCK DIAGRAM**



**FIGURE 33-2: EUSART RECEIVE BLOCK DIAGRAM**



The operation of the EUSART module is controlled through three registers:

- Transmit Status and Control (TXxSTA)
- Receive Status and Control (RCxSTA)
- Baud Rate Control (BAUDxCON)

These registers are detailed in [Register 33-1](#), [Register 33-2](#) and [Register 33-3](#), respectively.

The RX and CK input pins are selected with the RXPPS and CKPPS registers, respectively. TX, CK and DT output pins are selected with each pin's RxyPPS register. Since the RX input is coupled with the DT output in Synchronous mode, it is the user's responsibility to select the same pin for both of these functions when operating in Synchronous mode. The EUSART control logic will control the data direction drivers automatically.

## 33.1 EUSART Asynchronous Mode

The EUSART transmits and receives data using the standard Non-Return-to-Zero (NRZ) format. NRZ is implemented with two levels: a  $V_{OH}$  Mark state which represents a '1' data bit, and a  $V_{OL}$  Space state which represents a '0' data bit. NRZ refers to the fact that consecutively transmitted data bits of the same value stay at the output level of that bit without returning to a neutral level between each bit transmission. An NRZ transmission port Idles in the Mark state. Each character transmission consists of one Start bit, followed by eight or nine data bits and is always terminated by one or more Stop bits. The Start bit is always a space and the Stop bits are always marks. The most common data format is eight bits. Each transmitted bit persists for a period of  $1/(\text{Baud Rate})$ . An on-chip dedicated 8-bit/16-bit Baud Rate Generator is used to derive standard baud rate frequencies from the system oscillator. See [Table 33-5](#) for examples of baud rate configurations.

The EUSART transmits and receives the LSb first. The EUSART's transmitter and receiver are functionally independent, but share the same data format and baud rate. Parity is not supported by the hardware, but can be implemented in software and stored as the ninth data bit.

### 33.1.1 EUSART ASYNCHRONOUS TRANSMITTER

The EUSART transmitter block diagram is shown in [Figure 33-1](#). The heart of the transmitter is the serial Transmit Shift Register (TSR), which is not directly accessible by software. The TSR obtains its data from the transmit buffer, which is the TXxREG register.

#### 33.1.1.1 Enabling the Transmitter

The EUSART transmitter is enabled for asynchronous operations by configuring the following three control bits:

- TXEN = 1
- SYNC = 0
- SPEN = 1

All other EUSART control bits are assumed to be in their default state.

Setting the TXEN bit of the TXxSTA register enables the transmitter circuitry of the EUSART. Clearing the SYNC bit of the TXxSTA register configures the EUSART for asynchronous operation. Setting the SPEN bit of the RCxSTA register enables the EUSART and automatically configures the TX/CK I/O pin as an output. If the TX/CK pin is shared with an analog peripheral, the analog I/O function must be disabled by clearing the corresponding ANSELx bit.

**Note:** The TXIF transmitter interrupt flag is set when the TXEN enable bit is set.

#### 33.1.1.2 Transmitting Data

A transmission is initiated by writing a character to the TXxREG register. If this is the first character, or the previous character has been completely flushed from the TSR, the data in the TXxREG is immediately transferred to the TSR register. If the TSR still contains all or part of a previous character, the new character data is held in the TXxREG until the Stop bit of the previous character has been transmitted. The pending character in the TXxREG is then transferred to the TSR in one  $T_{CY}$  immediately following the Stop bit transmission. The transmission of the Start bit, data bits and Stop bit sequence commences immediately following the transfer of the data to the TSR from the TXxREG.

#### 33.1.1.3 Transmit Data Polarity

The polarity of the transmit data can be controlled with the SCKP bit of the BAUDxCON register. The default state of this bit is '0' which selects high true transmit Idle and data bits. Setting the SCKP bit to '1' will invert the transmit data resulting in low true Idle and data bits. The SCKP bit controls transmit data polarity in Asynchronous mode only. In Synchronous mode, the SCKP bit has a different function. See [Section 33.5.1.2 "Clock Polarity"](#).

#### 33.1.1.4 Transmit Interrupt Flag

The TXIF interrupt flag bit of the PIR1 register is set whenever the EUSART transmitter is enabled and no character is being held for transmission in the TXxREG. In other words, the TXIF bit is only clear when the TSR is busy with a character and a new character has been queued for transmission in the TXxREG. The TXIF flag bit is not cleared immediately upon writing TXxREG. TXIF becomes valid in the second instruction cycle following the write execution. Polling TXIF immediately following the TXxREG write will return invalid results. The TXIF bit is read-only, it cannot be set or cleared by software.

The TXIF interrupt can be enabled by setting the TXIE interrupt enable bit of the PIE1 register. However, the TXIF flag bit will be set whenever the TXxREG is empty, regardless of the state of TXIE enable bit.

To use interrupts when transmitting data, set the TXIE bit only when there is more data to send. Clear the TXIE interrupt enable bit upon writing the last character of the transmission to the TXxREG.

## 33.1.1.5 TSR Status

The TRMT bit of the TXxSTA register indicates the status of the TSR register. This is a read-only bit. The TRMT bit is set when the TSR register is empty and is cleared when a character is transferred to the TSR register from the TXxREG. The TRMT bit remains clear until all bits have been shifted out of the TSR register. No interrupt logic is tied to this bit, so the user has to poll this bit to determine the TSR status.

**Note:** The TSR register is not mapped in data memory, so it is not available to the user.

## 33.1.1.6 Transmitting 9-Bit Characters

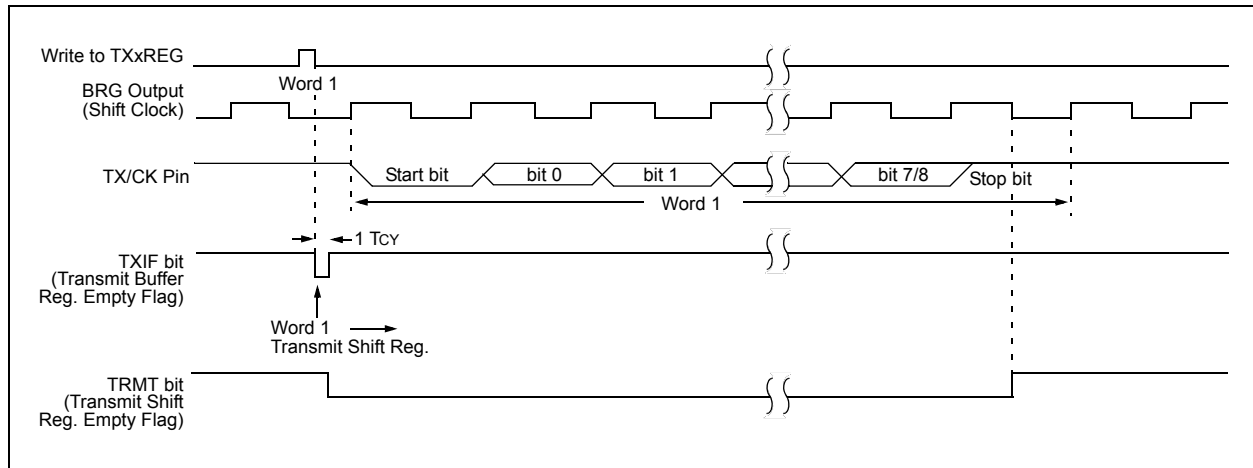
The EUSART supports 9-bit character transmissions. When the TX9 bit of the TXxSTA register is set, the EUSART will shift nine bits out for each character transmitted. The TX9D bit of the TXxSTA register is the ninth, and Most Significant data bit. When transmitting 9-bit data, the TX9D data bit must be written before writing the eight Least Significant bits into the TXxREG. All nine bits of data will be transferred to the TSR shift register immediately after the TXxREG is written.

A special 9-Bit Address mode is available for use with multiple receivers. See [Section 33.1.2.7 “Address Detection”](#) for more information on the Address mode.

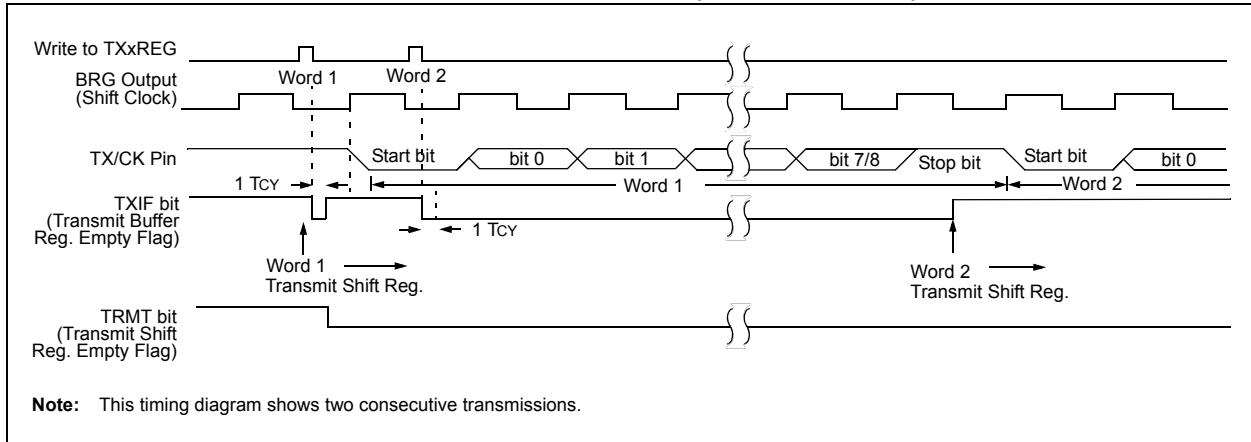
## 33.1.1.7 Asynchronous Transmission Setup

1. Initialize the SPxBRGH, SPxBRGL register pair and the BRGH and BRG16 bits to achieve the desired baud rate (see [Section 33.4 “EUSART Baud Rate Generator \(BRG\)”](#)).
2. Enable the asynchronous serial port by clearing the SYNC bit and setting the SPEN bit.
3. If 9-bit transmission is desired, set the TX9 control bit. A set ninth data bit will indicate that the eight Least Significant data bits are an address when the receiver is set for address detection.
4. Set SCKP bit if inverted transmit is desired.
5. Enable the transmission by setting the TXEN control bit. This will cause the TXIF interrupt bit to be set.
6. If interrupts are desired, set the TXIE interrupt enable bit of the PIE1 register. An interrupt will occur immediately provided that the GIE and PEIE bits of the INTCON register are also set.
7. If 9-bit transmission is selected, the ninth bit should be loaded into the TX9D data bit.
8. Load 8-bit data into the TXxREG register. This will start the transmission.

**FIGURE 33-3: ASYNCHRONOUS TRANSMISSION**



**FIGURE 33-4: ASYNCHRONOUS TRANSMISSION (BACK-TO-BACK)**



**TABLE 33-1: SUMMARY OF REGISTERS ASSOCIATED WITH ASYNCHRONOUS TRANSMISSION**

Name	Bit 7	Bit 6	Bit 5	Bit 4	Bit 3	Bit 2	Bit 1	Bit 0	Register on Page
ANSELA	—	—	—	ANSA4	—	ANSA<2:0>			139
ANSELB <sup>(1)</sup>	ANSB<7:4>				—	—	—	—	145
ANSELC	ANSC<7:6> <sup>(1)</sup>			—	—	ANSC<3:0>			150
BAUD1CON	ABDOVF	RCIDL	—	SCKP	BRG16	—	WUE	ABDEN	446
INTCON	GIE	PEIE	TMR0IE	INTE	IOCIE	TMR0IF	INTF	IOCIF	101
PIE1	TMR1GIE	ADIE	RCIE	TXIE	SSP1IE	CCP1IE	TMR2IE	TMR1IE	102
PIR1	TMR1GIF	ADIF	RCIF	TXIF	SSP1IF	CCP1IF	TMR2IF	TMR1IF	106
RC1STA	SPEN	RX9	SREN	CREN	ADDEN	FERR	OERR	RX9D	445
RxyPPS	—	—	—	RxyPPS<4:0>					156, 158
SP1BRGL	BRG<7:0>								447*
SP1BRGH	BRG<15:8>								447*
TRISA	—	—	TRISA<5:4>		— <sup>(2)</sup>	TRISA<2:0>			138
TRISB <sup>(1)</sup>	TRISB<7:4>								144
TRISC	TRISC<7:6> <sup>(1)</sup>			TRISC<5:0>					149
TX1REG	EUSART Transmit Data Register								437*
TX1STA	CSRC	TX9	TXEN	SYNC	SENDB	BRGH	TRMT	TX9D	444

**Legend:** — = unimplemented location, read as '0'. Shaded cells are not used for asynchronous transmission.

\* Page provides register information.

**Note 1:** PIC16(L)F1768/9 only.

**Note 2:** Unimplemented, read as '1'.

## 33.1.2 EUSART ASYNCHRONOUS RECEIVER

The Asynchronous mode is typically used in RS-232 systems. The receiver block diagram is shown in [Figure 33-2](#). The data is received on the RX/DT pin and drives the data recovery block. The data recovery block is actually a high-speed shifter operating at 16 times the baud rate, whereas the serial Receive Shift Register (RSR) operates at the bit rate. When all eight or nine bits of the character have been shifted in, they are immediately transferred to a two-character First-In-First-Out (FIFO) memory. The FIFO buffering allows reception of two complete characters and the start of a third character before software must start servicing the EUSART receiver. The FIFO and RSR registers are not directly accessible by software. Access to the received data is via the RCxREG register.

### 33.1.2.1 Enabling the Receiver

The EUSART receiver is enabled for asynchronous operation by configuring the following three control bits:

- CREN = 1
- SYNC = 0
- SPEN = 1

All other EUSART control bits are assumed to be in their default state.

Setting the CREN bit of the RCxSTA register enables the receiver circuitry of the EUSART. Clearing the SYNC bit of the TXxSTA register configures the EUSART for asynchronous operation. Setting the SPEN bit of the RCxSTA register enables the EUSART. The programmer must set the corresponding TRIS bit to configure the RX/DT I/O pin as an input.

**Note:** If the RX/DT function is on an analog pin, the corresponding ANSELx bit must be cleared for the receiver to function.

### 33.1.2.2 Receiving Data

The receiver data recovery circuit initiates character reception on the falling edge of the first bit. The first bit, also known as the Start bit, is always a zero. The data recovery circuit counts one-half bit time to the center of the Start bit and verifies that the bit is still a zero. If it is not a zero then the data recovery circuit aborts character reception, without generating an error, and resumes looking for the falling edge of the Start bit. If the Start bit zero verification succeeds, then the data recovery circuit counts a full bit time to the center of the next bit. The bit is then sampled by a majority detect circuit and the resulting '0' or '1' is shifted into the RSR. This repeats until all data bits have been sampled and shifted into the RSR. One final bit time is measured and the level sampled. This is the Stop bit, which is always a '1'. If the data recovery circuit samples a '0' in the Stop bit position then a framing error is set for this character, otherwise the framing error is cleared for this character. See [Section 33.1.2.4 "Receive Framing Error"](#) for more information on framing errors.

Immediately after all data bits and the Stop bit have been received, the character in the RSR is transferred to the EUSART receive FIFO and the RCIF interrupt flag bit of the PIR1 register is set. The top character in the FIFO is transferred out of the FIFO by reading the RCxREG register.

**Note:** If the receive FIFO is overrun, no additional characters will be received until the overrun condition is cleared. See [Section 33.1.2.5 "Receive Overrun Error"](#) for more information on overrun errors.

### 33.1.2.3 Receive Interrupts

The RCIF interrupt flag bit of the PIR1 register is set whenever the EUSART receiver is enabled and there is an unread character in the receive FIFO. The RCIF interrupt flag bit is read-only; it cannot be set or cleared by software.

RCIF interrupts are enabled by setting all of the following bits:

- RCIE, Interrupt Enable bit of the PIE1 register
- PEIE, Peripheral Interrupt Enable bit of the INTCON register
- GIE, Global Interrupt Enable bit of the INTCON register

The RCIF interrupt flag bit will be set when there is an unread character in the FIFO, regardless of the state of interrupt enable bits.



## 33.1.2.4 Receive Framing Error

Each character in the receive FIFO buffer has a corresponding framing error status bit. A framing error indicates that a Stop bit was not seen at the expected time. The framing error status is accessed via the FERR bit of the RCxSTA register. The FERR bit represents the status of the top unread character in the receive FIFO. Therefore, the FERR bit must be read before reading the RCxREG.

The FERR bit is read-only and only applies to the top unread character in the receive FIFO. A framing error (FERR = 1) does not preclude reception of additional characters. It is not necessary to clear the FERR bit. Reading the next character from the FIFO buffer will advance the FIFO to the next character and the next corresponding framing error.

The FERR bit can be forced clear by clearing the SPEN bit of the RCxSTA register which resets the EUSART. Clearing the CREN bit of the RCxSTA register does not affect the FERR bit. A framing error by itself does not generate an interrupt.

<b>Note:</b> If all receive characters in the receive FIFO have framing errors, repeated reads of the RCxREG will not clear the FERR bit.
---

## 33.1.2.5 Receive Overrun Error

The receive FIFO buffer can hold two characters. An overrun error will be generated if a third character, in its entirety, is received before the FIFO is accessed. When this happens, the OERR bit of the RCxSTA register is set. The characters already in the FIFO buffer can be read, but no additional characters will be received until the error is cleared. The error must be cleared by either clearing the CREN bit of the RCxSTA register or by resetting the EUSART by clearing the SPEN bit of the RCxSTA register.

## 33.1.2.6 Receiving 9-Bit Characters

The EUSART supports 9-bit character reception. When the RX9 bit of the RCxSTA register is set, the EUSART will shift nine bits into the RSR for each character received. The RX9D bit of the RCxSTA register is the ninth and Most Significant data bit of the top unread character in the receive FIFO. When reading 9-bit data from the receive FIFO buffer, the RX9D data bit must be read before reading the eight Least Significant bits from the RCxREG.

## 33.1.2.7 Address Detection

A special Address Detection mode is available for use when multiple receivers share the same transmission line, such as in RS-485 systems. Address detection is enabled by setting the ADDEN bit of the RCxSTA register.

Address detection requires 9-bit character reception. When address detection is enabled, only characters with the ninth data bit set will be transferred to the receive FIFO buffer, thereby setting the RCIF interrupt bit. All other characters will be ignored.

Upon receiving an address character, user software determines if the address matches its own. Upon address match, user software must disable address detection by clearing the ADDEN bit before the next Stop bit occurs. When user software detects the end of the message, determined by the message protocol used, software places the receiver back into the Address Detection mode by setting the ADDEN bit.

## 33.1.2.8 Asynchronous Reception Setup

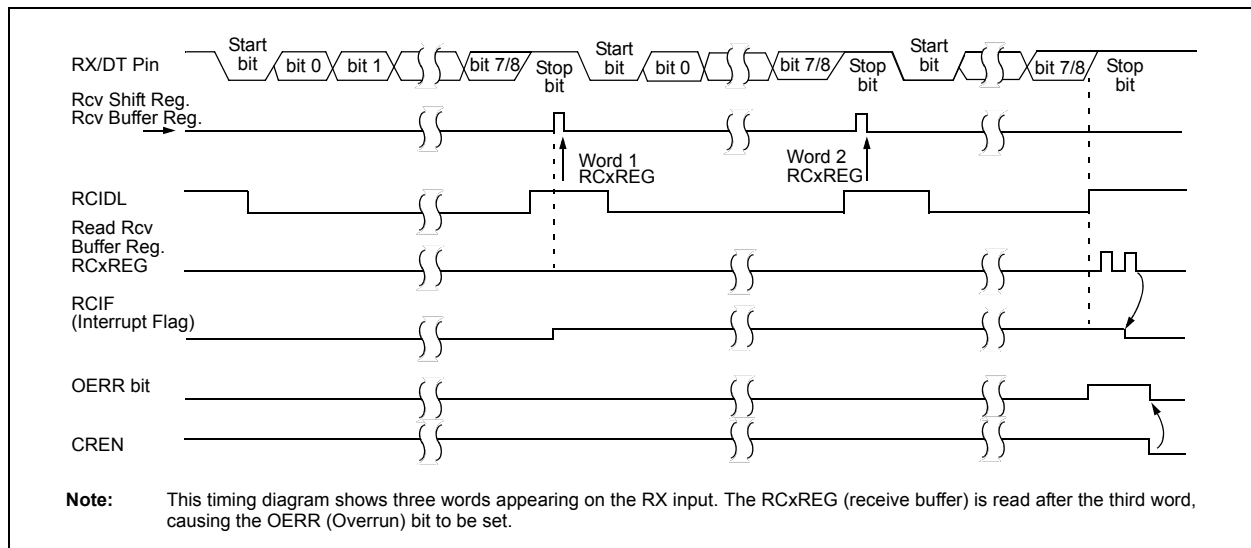
1. Initialize the SPxBRGH, SPxBRGL register pair, and the BRGH and BRG16 bits to achieve the desired baud rate (see [Section 33.4 “EUSART Baud Rate Generator \(BRG\)”](#)).
2. Clear the ANSELx bit for the RX pin (if applicable).
3. Enable the serial port by setting the SPEN bit. The SYNC bit must be clear for asynchronous operation.
4. If interrupts are desired, set the RCIE bit of the PIE1 register, and the GIE and PEIE bits of the INTCON register.
5. If 9-bit reception is desired, set the RX9 bit.
6. Enable reception by setting the CREN bit.
7. The RCIF interrupt flag bit will be set when a character is transferred from the RSR to the receive buffer. An interrupt will be generated if the RCIE interrupt enable bit was also set.
8. Read the RCxSTA register to get the error flags and, if 9-bit data reception is enabled, the ninth data bit.
9. Get the received eight Least Significant data bits from the receive buffer by reading the RCxREG register.
10. If an overrun occurred, clear the OERR flag by clearing the CREN receiver enable bit.

## 33.1.2.9 9-bit Address Detection Mode Setup

This mode would typically be used in RS-485 systems. To set up an Asynchronous Reception with Address Detect Enable:

1. Initialize the SPxBRGH, SPxBRGL register pair, and the BRGH and BRG16 bits to achieve the desired baud rate (see [Section 33.4 “EUSART Baud Rate Generator \(BRG\)”](#)).
2. Clear the ANSELx bit for the RX pin (if applicable).
3. Enable the serial port by setting the SPEN bit. The SYNC bit must be clear for asynchronous operation.
4. If interrupts are desired, set the RCIE bit of the PIE1 register, and the GIE and PEIE bits of the INTCON register.
5. Enable 9-bit reception by setting the RX9 bit.
6. Enable address detection by setting the ADDEN bit.
7. Enable reception by setting the CREN bit.
8. The RCIF interrupt flag bit will be set when a character with the ninth bit set is transferred from the RSR to the receive buffer. An interrupt will be generated if the RCIE interrupt enable bit was also set.
9. Read the RCxSTA register to get the error flags. The ninth data bit will always be set.
10. Get the received eight Least Significant data bits from the receive buffer by reading the RCxREG register. Software determines if this is the device's address.
11. If an overrun occurred, clear the OERR flag by clearing the CREN receiver enable bit.
12. If the device has been addressed, clear the ADDEN bit to allow all received data into the receive buffer and generate interrupts.

**FIGURE 33-5: ASYNCHRONOUS RECEPTION**



**TABLE 33-2: SUMMARY OF REGISTERS ASSOCIATED WITH ASYNCHRONOUS RECEPTION**

Name	Bit 7	Bit 6	Bit 5	Bit 4	Bit 3	Bit 2	Bit 1	Bit 0	Register on Page
ANSELA	—	—	—	ANSA4	—	ANSA<2:0>			139
ANSELB <sup>(1)</sup>	ANSB<7:4>				—	—	—	—	145
ANSELC	ANSC<7:6> <sup>(1)</sup>		—	—	ANSC<3:0>				150
BAUD1CON	ABDOVF	RCIDL	—	SCKP	BRG16	—	WUE	ABDEN	446
INTCON	GIE	PEIE	TMR0IE	INTE	IOCFIE	TMR0IF	INTF	IOCFIF	101
PIE1	TMR1GIE	ADIE	RCIE	TXIE	SSP1IE	CCP1IE	TMR2IE	TMR1IE	102
PIR1	TMR1GIF	ADIF	RCIF	TXIF	SSP1IF	CCP1IF	TMR2IF	TMR1IF	106
RC1REG	EUSART Receive Data Register								440*
RC1STA	SPEN	RX9	SREN	CREN	ADDEN	FERR	OERR	RX9D	445
RxyPPS	—	—	—	RxyPPS<4:0>					156
SP1BRGL	BRG<7:0>								447
SP1BRGH	BRG<15:8>								447
TRISA	—	—	TRISA<5:4>		— <sup>(2)</sup>	TRISA<2:0>			138
TRISB <sup>(1)</sup>	TRISB<7:4>				—	—	—	—	144
TRISC	TRISC<7:6> <sup>(1)</sup>		TRISC<5:0>						149
TX1STA	CSRC	TX9	TXEN	SYNC	SEnDB	BRGH	TRMT	TX9D	444

**Legend:** — = unimplemented location, read as '0'. Shaded cells are not used for asynchronous reception.

\* Page provides register information.

**Note 1:** PIC16(L)F1768/9 only.

**Note 2:** Unimplemented, read as '1'.

### 33.2 Clock Accuracy with Asynchronous Operation

The factory calibrates the Internal Oscillator Block (INTOSC) output. However, the INTOSC frequency may drift as V<sub>DD</sub> or temperature changes and this directly affects the asynchronous baud rate. Two methods may be used to adjust the baud rate clock, but both require a reference clock source of some kind.

The first (preferred) method uses the OSCTUNE register to adjust the INTOSC output. Adjusting the value in the OSCTUNE register allows for fine resolution changes to the system clock source. See [Section 5.2.2.3 “Internal Oscillator Frequency Adjustment”](#) for more information.

The other method adjusts the value in the Baud Rate Generator. This can be done automatically with the Auto-Baud Detect feature (see [Section 33.4.1 “Auto-Baud Detect”](#)). There may not be fine enough resolution when adjusting the Baud Rate Generator to compensate for a gradual change in the peripheral clock frequency.

## 33.3 Register Definitions: EUSART Control

### REGISTER 33-1: TX1STA: TRANSMIT STATUS AND CONTROL REGISTER

R/W-0	R/W-0/0	R/W-0/0	R/W-0/0	R/W-0/0	R/W-0/0	R-1/1	R/W-0/0
CSRC	TX9	TXEN <sup>(1)</sup>	SYNC	SENDB	BRGH	TRMT	TX9D
bit 7						bit 0	

#### Legend:

R = Readable bit

W = Writable bit

u = Bit is unchanged

x = Bit is unknown

U = Unimplemented bit, read as '0'

'1' = Bit is set

'0' = Bit is cleared

-n/n = Value at POR and BOR/Value at all other Resets

- bit 7      **CSRC:** Clock Source Select bit  
Asynchronous mode:  
 Don't care.  
Synchronous mode:  
 1 = Master mode (clock generated internally from BRG)  
 0 = Slave mode (clock from external source)
- bit 6      **TX9:** 9-Bit Transmit Enable bit  
 1 = Selects 9-bit transmission  
 0 = Selects 8-bit transmission
- bit 5      **TXEN:** Transmit Enable bit<sup>(1)</sup>  
 1 = Transmit is enabled  
 0 = Transmit is disabled
- bit 4      **SYNC:** EUSART Mode Select bit  
 1 = Synchronous mode  
 0 = Asynchronous mode
- bit 3      **SENDB:** Send Break Character bit  
Asynchronous mode:  
 1 = Sends Sync Break on next transmission (cleared by hardware upon completion)  
 0 = Sync Break transmission has completed  
Synchronous mode:  
 Don't care.
- bit 2      **BRGH:** High Baud Rate Select bit  
Asynchronous mode:  
 1 = High speed  
 0 = Low speed  
Synchronous mode:  
 Unused in this mode.
- bit 1      **TRMT:** Transmit Shift Register Status bit  
 1 = TSR is empty  
 0 = TSR is full
- bit 0      **TX9D:** Ninth bit of Transmit Data  
 Can be address/data bit or a parity bit.

**Note 1:** SREN/CREN overrides TXEN in Sync mode.

# PIC16(L)F1764/5/8/9

## REGISTER 33-2: RC1STA: RECEIVE STATUS AND CONTROL REGISTER

R/W-0/0	R/W-0/0	R/W-0/0	R/W-0/0	R/W-0/0	R-0/0	R-0/0	R-0/0
SPEN	RX9	SREN	CREN	ADDEN	FERR	OERR	RX9D
bit 7							bit 0

### Legend:

R = Readable bit	W = Writable bit	
u = Bit is unchanged	x = Bit is unknown	U = Unimplemented bit, read as '0'
'1' = Bit is set	'0' = Bit is cleared	-n/n = Value at POR and BOR/Value at all other Resets

bit 7	<p><b>SPEN:</b> Serial Port Enable bit</p> <p>1 = Serial port is enabled</p> <p>0 = Serial port is disabled (held in Reset)</p>
bit 6	<p><b>RX9:</b> 9-Bit Receive Enable bit</p> <p>1 = Selects 9-bit reception</p> <p>0 = Selects 8-bit reception</p>
bit 5	<p><b>SREN:</b> Single Receive Enable bit</p> <p><u>Asynchronous mode:</u> Don't care.</p> <p><u>Synchronous mode – Master:</u> 1 = Enables single receive 0 = Disables single receive This bit is cleared after reception is complete.</p> <p><u>Synchronous mode – Slave:</u> Don't care.</p>
bit 4	<p><b>CREN:</b> Continuous Receive Enable bit</p> <p><u>Asynchronous mode:</u> 1 = Enables receiver 0 = Disables receiver</p> <p><u>Synchronous mode:</u> 1 = Enables continuous receive until enable bit, CREN, is cleared (CREN overrides SREN) 0 = Disables continuous receive</p>
bit 3	<p><b>ADDEN:</b> Address Detect Enable bit</p> <p><u>Asynchronous mode, 9-bit (RX9 = 1):</u> 1 = Enables address detection, enables interrupt and loads the receive buffer when RSR&lt;8&gt; is set 0 = Disables address detection, all bytes are received and ninth bit can be used as parity bit</p> <p><u>Asynchronous mode, 8-bit (RX9 = 0):</u> Don't care.</p>
bit 2	<p><b>FERR:</b> Framing Error bit</p> <p>1 = Framing error (can be updated by reading RCxREG register and receiving next valid byte)</p> <p>0 = No framing error</p>
bit 1	<p><b>OERR:</b> Overrun Error bit</p> <p>1 = Overrun error (can be cleared by clearing bit, CREN)</p> <p>0 = No overrun error</p>
bit 0	<p><b>RX9D:</b> Ninth bit of Received Data</p> <p>This can be address/data bit or a parity bit and must be calculated by user firmware.</p>

# PIC16(L)F1764/5/8/9

## REGISTER 33-3: BAUD1CON: BAUD RATE CONTROL REGISTER

R-0/0	R-1/1	U-0	R/W-0/0	R/W-0/0	U-0	R/W-0/0	R/W-0/0
ABDOVF	RCIDL	—	SCKP	BRG16	—	WUE	ABDEN
bit 7							bit 0

### Legend:

R = Readable bit	W = Writable bit	
u = Bit is unchanged	x = Bit is unknown	U = Unimplemented bit, read as '0'
'1' = Bit is set	'0' = Bit is cleared	-n/n = Value at POR and BOR/Value at all other Resets

bit 7	<p><b>ABDOVF:</b> Auto-Baud Detect Overflow bit</p> <p><u>Asynchronous mode:</u> 1 = Auto-baud timer overflowed 0 = Auto-baud timer did not overflow</p> <p><u>Synchronous mode:</u> Don't care.</p>
bit 6	<p><b>RCIDL:</b> Receive Idle Flag bit</p> <p><u>Asynchronous mode:</u> 1 = Receiver is Idle 0 = Start bit has been received and the receiver is receiving</p> <p><u>Synchronous mode:</u> Don't care.</p>
bit 5	<b>Unimplemented:</b> Read as '0'
bit 4	<p><b>SCKP:</b> Synchronous Clock Polarity Select bit</p> <p><u>Asynchronous mode:</u> 1 = Transmit inverted data to the TX/CK pin 0 = Transmit noninverted data to the TX/CK pin</p> <p><u>Synchronous mode:</u> 1 = Data is clocked on rising edge of the clock 0 = Data is clocked on falling edge of the clock</p>
bit 3	<p><b>BRG16:</b> 16-bit Baud Rate Generator bit</p> <p>1 = 16-bit Baud Rate Generator is used 0 = 8-bit Baud Rate Generator is used</p>
bit 2	<b>Unimplemented:</b> Read as '0'
bit 1	<p><b>WUE:</b> Wake-up Enable bit</p> <p><u>Asynchronous mode:</u> 1 = Receiver is waiting for a falling edge, no character will be received, byte RCIF will be set; WUE will automatically clear after RCIF is set 0 = Receiver is operating normally</p> <p><u>Synchronous mode:</u> Don't care.</p>
bit 0	<p><b>ABDEN:</b> Auto-Baud Detect Enable bit</p> <p><u>Asynchronous mode:</u> 1 = Auto-Baud Detect mode is enabled (clears when auto-baud is complete) 0 = Auto-Baud Detect mode is disabled</p> <p><u>Synchronous mode:</u> Don't care.</p>

## 33.4 EUSART Baud Rate Generator (BRG)

The Baud Rate Generator (BRG) is an 8-bit or 16-bit timer that is dedicated to the support of both the asynchronous and synchronous EUSART operation. By default, the BRG operates in 8-bit mode. Setting the BRG16 bit of the BAUDxCON register selects 16-bit mode.

The SPxBRGH, SPxBRGL register pair determines the period of the free-running baud rate timer. In Asynchronous mode, the multiplier of the baud rate period is determined by both the BRGH bit of the TXxSTA register and the BRG16 bit of the BAUDxCON register. In Synchronous mode, the BRGH bit is ignored.

Table 33-3 contains the formulas for determining the baud rate. Example 33-1 provides a sample calculation for determining the baud rate and baud rate error.

Typical baud rates and error values for various Asynchronous modes have been computed for your convenience and are shown in Table 33-5. It may be advantageous to use the high baud rate (BRGH = 1) or the 16-bit BRG (BRG16 = 1) to reduce the baud rate error. The 16-Bit BRG mode is used to achieve slow baud rates for fast oscillator frequencies.

Writing a new value to the SPxBRGH, SPxBRGL register pair causes the BRG timer to be reset (or cleared). This ensures that the BRG does not wait for a timer overflow before outputting the new baud rate.

If the system clock is changed during an active receive operation, a receive error or data loss may result. To avoid this problem, check the status of the RCIDL bit to make sure that the receive operation is Idle before changing the system clock.

### EXAMPLE 33-1: CALCULATING BAUD RATE ERROR

For a device with Fosc of 16 MHz, desired baud rate of 9600, Asynchronous mode, 8-bit BRG:

$$\text{Desired Baud Rate} = \frac{F_{OSC}}{64(SPBRGH:SPBRGL + 1)}$$

Solving for SPxBRGH:SPxBRGL:

$$X = \frac{F_{OSC}}{\text{Desired Baud Rate} \cdot 64} - 1$$

$$= \frac{16000000}{9600 \cdot 64} - 1$$

$$= [25.042] = 25$$

$$\text{Calculated Baud Rate} = \frac{16000000}{64(25 + 1)}$$

$$= 9615$$

$$\text{Error} = \frac{\text{Calc. Baud Rate} - \text{Desired Baud Rate}}{\text{Desired Baud Rate}}$$

$$= \frac{(9615 - 9600)}{9600} = 0.16\%$$

**TABLE 33-3: BAUD RATE FORMULAS**

Configuration Bits			BRG/EUSART Mode	Baud Rate Formula
SYNC	BRG16	BRGH		
0	0	0	8-bit/Asynchronous	$F_{osc}/[64 (n+1)]$
0	0	1	8-bit/Asynchronous	$F_{osc}/[16 (n+1)]$
0	1	0	16-bit/Asynchronous	
0	1	1	16-bit/Asynchronous	$F_{osc}/[4 (n+1)]$
1	0	x	8-bit/Synchronous	
1	1	x	16-bit/Synchronous	

**Legend:** x = Don't care, n = value of SPxBRGH, SPxBRGL register pair.

**TABLE 33-4: SUMMARY OF REGISTERS ASSOCIATED WITH THE BAUD RATE GENERATOR**

Name	Bit 7	Bit 6	Bit 5	Bit 4	Bit 3	Bit 2	Bit 1	Bit 0	Register on Page
BAUD1CON	ABDOVF	RCIDL	—	SCKP	BRG16	—	WUE	ABDEN	446
RC1STA	SPEN	RX9	SREN	CREN	ADDEN	FERR	OERR	RX9D	445
SP1BRGL	BRG<7:0>								447
SP1BRGH	BRG<15:8>								447
TX1STA	CSRC	TX9	TXEN	SYNC	SENDB	BRGH	TRMT	TX9D	444

**Legend:** — = unimplemented location, read as '0'. Shaded cells are not used for the Baud Rate Generator.

\* Page provides register information.



**TABLE 33-5: BAUD RATES FOR ASYNCHRONOUS MODES**

BAUD RATE	SYNC = 0, BRGH = 0, BRG16 = 0											
	Fosc = 32.000 MHz			Fosc = 20.000 MHz			Fosc = 18.432 MHz			Fosc = 11.0592 MHz		
	Actual Rate	% Error	SPxBRG value (decimal)	Actual Rate	% Error	SPxBRG value (decimal)	Actual Rate	% Error	SPxBRG value (decimal)	Actual Rate	% Error	SPxBRG value (decimal)
300	—	—	—	—	—	—	—	—	—	—	—	—
1200	—	—	—	1221	1.73	255	1200	0.00	239	1200	0.00	143
2400	2404	0.16	207	2404	0.16	129	2400	0.00	119	2400	0.00	71
9600	9615	0.16	51	9470	-1.36	32	9600	0.00	29	9600	0.00	17
10417	10417	0.00	47	10417	0.00	29	10286	-1.26	27	10165	-2.42	16
19.2k	19.23k	0.16	25	19.53k	1.73	15	19.20k	0.00	14	19.20k	0.00	8
57.6k	55.55k	-3.55	3	—	—	—	57.60k	0.00	7	57.60k	0.00	2
115.2k	—	—	—	—	—	—	—	—	—	—	—	—

BAUD RATE	SYNC = 0, BRGH = 0, BRG16 = 0											
	Fosc = 8.000 MHz			Fosc = 4.000 MHz			Fosc = 3.6864 MHz			Fosc = 1.000 MHz		
	Actual Rate	% Error	SPxBRG value (decimal)	Actual Rate	% Error	SPxBRG value (decimal)	Actual Rate	% Error	SPxBRG value (decimal)	Actual Rate	% Error	SPxBRG value (decimal)
300	—	—	—	300	0.16	207	300	0.00	191	300	0.16	51
1200	1202	0.16	103	1202	0.16	51	1200	0.00	47	1202	0.16	12
2400	2404	0.16	51	2404	0.16	25	2400	0.00	23	—	—	—
9600	9615	0.16	12	—	—	—	9600	0.00	5	—	—	—
10417	10417	0.00	11	10417	0.00	5	—	—	—	—	—	—
19.2k	—	—	—	—	—	—	19.20k	0.00	2	—	—	—
57.6k	—	—	—	—	—	—	57.60k	0.00	0	—	—	—
115.2k	—	—	—	—	—	—	—	—	—	—	—	—

BAUD RATE	SYNC = 0, BRGH = 1, BRG16 = 0											
	Fosc = 32.000 MHz			Fosc = 20.000 MHz			Fosc = 18.432 MHz			Fosc = 11.0592 MHz		
	Actual Rate	% Error	SPxBRG value (decimal)	Actual Rate	% Error	SPxBRG value (decimal)	Actual Rate	% Error	SPxBRG value (decimal)	Actual Rate	% Error	SPxBRG value (decimal)
300	—	—	—	—	—	—	—	—	—	—	—	—
1200	—	—	—	—	—	—	—	—	—	—	—	—
2400	—	—	—	—	—	—	—	—	—	—	—	—
9600	9615	0.16	207	9615	0.16	129	9600	0.00	119	9600	0.00	71
10417	10417	0.00	191	10417	0.00	119	10378	-0.37	110	10473	0.53	65
19.2k	19.23k	0.16	103	19.23k	0.16	64	19.20k	0.00	59	19.20k	0.00	35
57.6k	57.14k	-0.79	34	56.82k	-1.36	21	57.60k	0.00	19	57.60k	0.00	11
115.2k	117.64k	2.12	16	113.64k	-1.36	10	115.2k	0.00	9	115.2k	0.00	5

**TABLE 33-5: BAUD RATES FOR ASYNCHRONOUS MODES (CONTINUED)**

BAUD RATE	SYNC = 0, BRGH = 1, BRG16 = 0											
	Fosc = 8.000 MHz			Fosc = 4.000 MHz			Fosc = 3.6864 MHz			Fosc = 1.000 MHz		
	Actual Rate	% Error	SPxBRG value (decimal)	Actual Rate	% Error	SPxBRG value (decimal)	Actual Rate	% Error	SPxBRG value (decimal)	Actual Rate	% Error	SPxBRG value (decimal)
300	—	—	—	—	—	—	—	—	—	300	0.16	207
1200	—	—	—	1202	0.16	207	1200	0.00	191	1202	0.16	51
2400	2404	0.16	207	2404	0.16	103	2400	0.00	95	2404	0.16	25
9600	9615	0.16	51	9615	0.16	25	9600	0.00	23	—	—	—
10417	10417	0.00	47	10417	0.00	23	10473	0.53	21	10417	0.00	5
19.2k	19231	0.16	25	19.23k	0.16	12	19.2k	0.00	11	—	—	—
57.6k	55556	-3.55	8	—	—	—	57.60k	0.00	3	—	—	—
115.2k	—	—	—	—	—	—	115.2k	0.00	1	—	—	—

BAUD RATE	SYNC = 0, BRGH = 0, BRG16 = 1											
	Fosc = 32.000 MHz			Fosc = 20.000 MHz			Fosc = 18.432 MHz			Fosc = 11.0592 MHz		
	Actual Rate	% Error	SPxBRG value (decimal)	Actual Rate	% Error	SPxBRG value (decimal)	Actual Rate	% Error	SPxBRG value (decimal)	Actual Rate	% Error	SPxBRG value (decimal)
300	300.0	0.00	6666	300.0	-0.01	4166	300.0	0.00	3839	300.0	0.00	2303
1200	1200	-0.02	3332	1200	-0.03	1041	1200	0.00	959	1200	0.00	575
2400	2401	-0.04	832	2399	-0.03	520	2400	0.00	479	2400	0.00	287
9600	9615	0.16	207	9615	0.16	129	9600	0.00	119	9600	0.00	71
10417	10417	0.00	191	10417	0.00	119	10378	-0.37	110	10473	0.53	65
19.2k	19.23k	0.16	103	19.23k	0.16	64	19.20k	0.00	59	19.20k	0.00	35
57.6k	57.14k	-0.79	34	56.818	-1.36	21	57.60k	0.00	19	57.60k	0.00	11
115.2k	117.6k	2.12	16	113.636	-1.36	10	115.2k	0.00	9	115.2k	0.00	5

BAUD RATE	SYNC = 0, BRGH = 0, BRG16 = 1											
	Fosc = 8.000 MHz			Fosc = 4.000 MHz			Fosc = 3.6864 MHz			Fosc = 1.000 MHz		
	Actual Rate	% Error	SPxBRG value (decimal)	Actual Rate	% Error	SPxBRG value (decimal)	Actual Rate	% Error	SPxBRG value (decimal)	Actual Rate	% Error	SPxBRG value (decimal)
300	299.9	-0.02	1666	300.1	0.04	832	300.0	0.00	767	300.5	0.16	207
1200	1199	-0.08	416	1202	0.16	207	1200	0.00	191	1202	0.16	51
2400	2404	0.16	207	2404	0.16	103	2400	0.00	95	2404	0.16	25
9600	9615	0.16	51	9615	0.16	25	9600	0.00	23	—	—	—
10417	10417	0.00	47	10417	0.00	23	10473	0.53	21	10417	0.00	5
19.2k	19.23k	0.16	25	19.23k	0.16	12	19.20k	0.00	11	—	—	—
57.6k	55556	-3.55	8	—	—	—	57.60k	0.00	3	—	—	—
115.2k	—	—	—	—	—	—	115.2k	0.00	1	—	—	—

**TABLE 33-5: BAUD RATES FOR ASYNCHRONOUS MODES (CONTINUED)**

BAUD RATE	SYNC = 0, BRGH = 1, BRG16 = 1 or SYNC = 1, BRG16 = 1											
	Fosc = 32.000 MHz			Fosc = 20.000 MHz			Fosc = 18.432 MHz			Fosc = 11.0592 MHz		
	Actual Rate	% Error	SPxBRG value (decimal)	Actual Rate	% Error	SPxBRG value (decimal)	Actual Rate	% Error	SPxBRG value (decimal)	Actual Rate	% Error	SPxBRG value (decimal)
300	300.0	0.00	26666	300.0	0.00	16665	300.0	0.00	15359	300.0	0.00	9215
1200	1200	0.00	6666	1200	-0.01	4166	1200	0.00	3839	1200	0.00	2303
2400	2400	0.01	3332	2400	0.02	2082	2400	0.00	1919	2400	0.00	1151
9600	9604	0.04	832	9597	-0.03	520	9600	0.00	479	9600	0.00	287
10417	10417	0.00	767	10417	0.00	479	10425	0.08	441	10433	0.16	264
19.2k	19.18k	-0.08	416	19.23k	0.16	259	19.20k	0.00	239	19.20k	0.00	143
57.6k	57.55k	-0.08	138	57.47k	-0.22	86	57.60k	0.00	79	57.60k	0.00	47
115.2k	115.9k	0.64	68	116.3k	0.94	42	115.2k	0.00	39	115.2k	0.00	23

BAUD RATE	SYNC = 0, BRGH = 1, BRG16 = 1 or SYNC = 1, BRG16 = 1											
	Fosc = 8.000 MHz			Fosc = 4.000 MHz			Fosc = 3.6864 MHz			Fosc = 1.000 MHz		
	Actual Rate	% Error	SPxBRG value (decimal)	Actual Rate	% Error	SPxBRG value (decimal)	Actual Rate	% Error	SPxBRG value (decimal)	Actual Rate	% Error	SPxBRG value (decimal)
300	300.0	0.00	6666	300.0	0.01	3332	300.0	0.00	3071	300.1	0.04	832
1200	1200	-0.02	1666	1200	0.04	832	1200	0.00	767	1202	0.16	207
2400	2401	0.04	832	2398	0.08	416	2400	0.00	383	2404	0.16	103
9600	9615	0.16	207	9615	0.16	103	9600	0.00	95	9615	0.16	25
10417	10417	0	191	10417	0.00	95	10473	0.53	87	10417	0.00	23
19.2k	19.23k	0.16	103	19.23k	0.16	51	19.20k	0.00	47	19.23k	0.16	12
57.6k	57.14k	-0.79	34	58.82k	2.12	16	57.60k	0.00	15	—	—	—
115.2k	117.6k	2.12	16	111.1k	-3.55	8	115.2k	0.00	7	—	—	—

## 33.4.1 AUTO-BAUD DETECT

The EUSART module supports automatic detection and calibration of the baud rate.

In the Auto-Baud Detect (ABD) mode, the clock to the BRG is reversed. Rather than the BRG clocking the incoming RX signal, the RX signal is timing the BRG. The Baud Rate Generator is used to time the period of a received 55h (ASCII “U”), which is the Sync character for the LIN bus. The unique feature of this character is that it has five rising edges including the Stop bit edge.

Setting the ABDEN bit of the BAUDxCON register starts the auto-baud calibration sequence. While the ABD sequence takes place, the EUSART state machine is held in Idle. On the first rising edge of the receive line, after the Start bit, the SPxBRG begins counting up using the BRG counter clock, as shown in Figure 33-6. The fifth rising edge will occur on the RX pin at the end of the eighth bit period. At that time, an accumulated value totaling the proper BRG period is left in the SPxBRGH, SPxBRGL register pair, the ABDEN bit is automatically cleared and the RCIF interrupt flag is set. The value in the RCxREG needs to be read to clear the RCIF interrupt. RCxREG content should be discarded. When calibrating for modes that do not use the SPxBRGH register, the user can verify that the SPxBRGL register did not overflow by checking for 00h in the SPxBRGH register.

The BRG auto-baud clock is determined by the BRG16 and BRGH bits as shown in Table 33-6. During ABD, both the SPxBRGH and SPxBRGL registers are used as a 16-bit counter, independent of the BRG16 bit setting. While calibrating the baud rate period, the SPxBRGH and SPxBRGL registers are clocked at

1/8th the BRG base clock rate. The resulting byte measurement is the average bit time when clocked at full speed.

**Note 1:** If the WUE bit is set with the ABDEN bit, Auto-Baud Detection will occur on the byte following the Break character (see Section 33.4.3 “Auto-Wake-up on Break”).

**2:** It is up to the user to determine that the incoming character baud rate is within the range of the selected BRG clock source. Some combinations of oscillator frequency and EUSART baud rates are not possible.

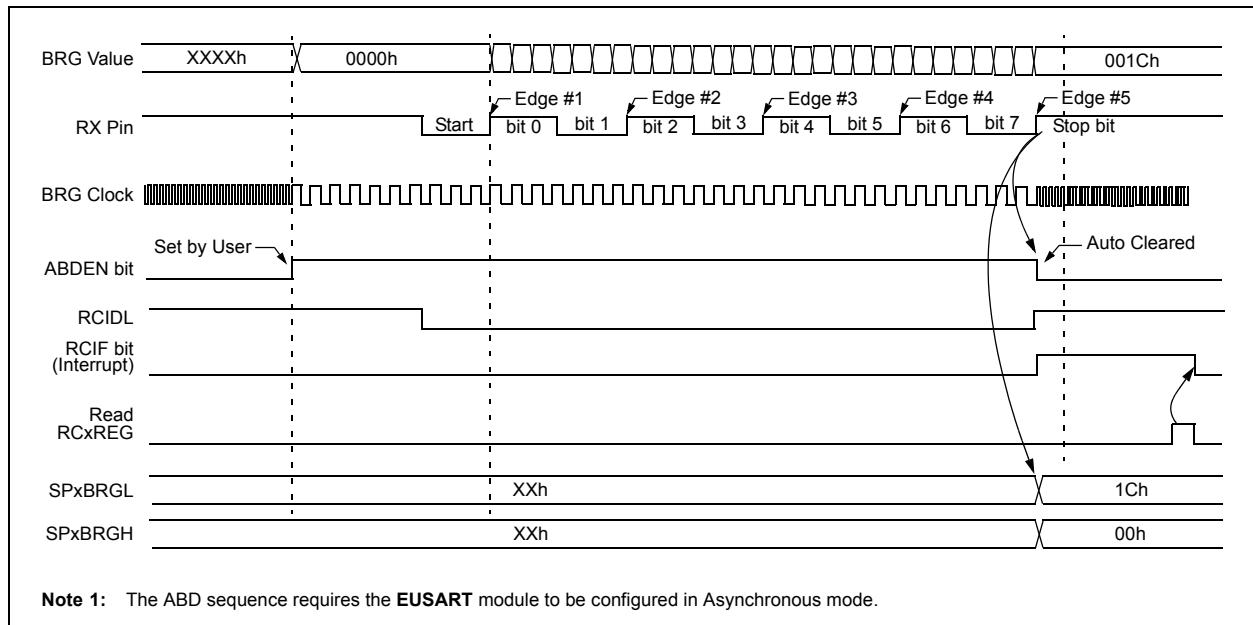
**3:** During the auto-baud process, the auto-baud counter starts counting at one. Upon completion of the auto-baud sequence, to achieve maximum accuracy, subtract 1 from the SPxBRGH:SPxBRGL register pair.

**TABLE 33-6: BRG COUNTER CLOCK RATES**

BRG16	BRGH	BRG Base Clock	BRG ABD Clock
0	0	Fosc/64	Fosc/512
0	1	Fosc/16	Fosc/128
1	0	Fosc/16	Fosc/128
1	1	Fosc/4	Fosc/32

**Note:** During the ABD sequence, the SPxBRGL and SPxBRGH registers are both used as a 16-bit counter, independent of the BRG16 setting.

**FIGURE 33-6: AUTOMATIC BAUD RATE CALIBRATION**



## 33.4.2 AUTO-BAUD OVERFLOW

During the course of Automatic Baud Detection, the ABDOVF bit of the BAUDxCON register will be set if the baud rate counter overflows before the fifth rising edge is detected on the RX pin. The ABDOVF bit indicates that the counter has exceeded the maximum count that can fit in the 16 bits of the SPxBRGH:SPxBRGL register pair. The overflow condition will set the RCIF flag. The counter continues to count until the fifth rising edge is detected on the RX pin. The RCIDL bit will remain false ('0') until the fifth rising edge, at which time, the RCIDL bit will be set. If the RCREG is read after the overflow occurs, but before the fifth rising edge, then the fifth rising edge will set the RCIF again.

Terminating the auto-baud process early to clear an overflow condition will prevent proper detection of the Sync character's fifth rising edge. If any falling edges of the Sync character have not yet occurred when the ABDEN bit is cleared, then those will be falsely detected as Start bits. The following steps are recommended to clear the overflow condition:

1. Read RCREG to clear RCIF.
2. If RCIDL is zero, then wait for RCIF and repeat Step 1.
3. Clear the ABDOVF bit.

## 33.4.3 AUTO-WAKE-UP ON BREAK

During Sleep mode, all clocks to the EUSART are suspended. Because of this, the Baud Rate Generator is inactive and a proper character reception cannot be performed. The auto-wake-up feature allows the controller to wake-up due to activity on the RX/DT line. This feature is available only in Asynchronous mode.

The auto-wake-up feature is enabled by setting the WUE bit of the BAUDxCON register. Once set, the normal receive sequence on RX/DT is disabled, and the EUSART remains in an Idle state, monitoring for a wake-up event independent of the CPU mode. A wake-up event consists of a high-to-low transition on the RX/DT line. (This coincides with the start of a Sync Break or a wake-up signal character for the LIN protocol.)

The EUSART module generates an RCIF interrupt coincident with the wake-up event. The interrupt is generated synchronously to the Q clocks in normal CPU operating modes (Figure 33-7), and asynchronously if the device is in Sleep mode (Figure 33-8). The interrupt condition is cleared by reading the RCxREG register.

The WUE bit is automatically cleared by the low-to-high transition on the RX line at the end of the Break. This signals to the user that the Break event is over. At this point, the EUSART module is in Idle mode waiting to receive the next character.

## 33.4.3.1 Special Considerations

### Break Character

To avoid character errors or character fragments during a wake-up event, the wake-up character must be all zeros.

When the wake-up is enabled, the function works independent of the low time on the data stream. If the WUE bit is set and a valid non-zero character is received, the low time from the Start bit to the first rising edge will be interpreted as the wake-up event. The remaining bits in the character will be received as a fragmented character and subsequent characters can result in framing or overrun errors.

Therefore, the initial character in the transmission must be all '0's. This must be ten or more bit times, 13 bit times recommended for LIN bus, or any number of bit times for standard RS-232 devices.

### Oscillator Start-up Time

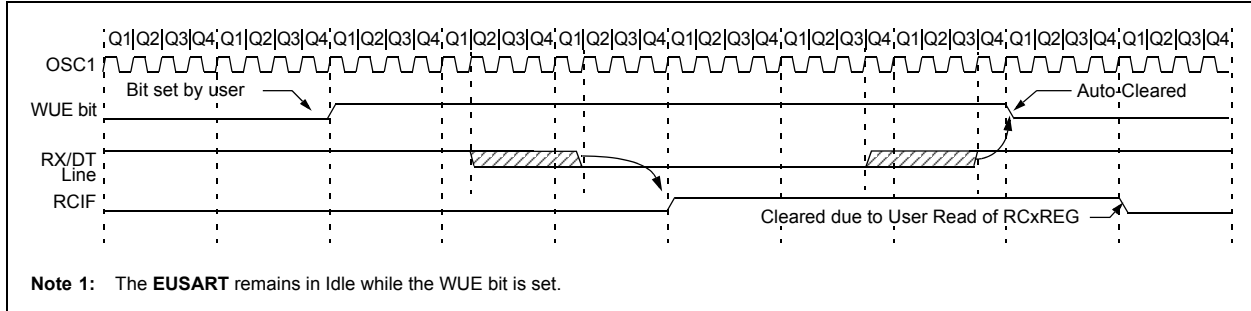
Oscillator start-up time must be considered, especially in applications using oscillators with longer start-up intervals (i.e., LP, XT or HS/PLL mode). The Sync Break (or wake-up signal) character must be of sufficient length, and be followed by a sufficient interval, to allow enough time for the selected oscillator to start and provide proper initialization of the EUSART.

### WUE Bit

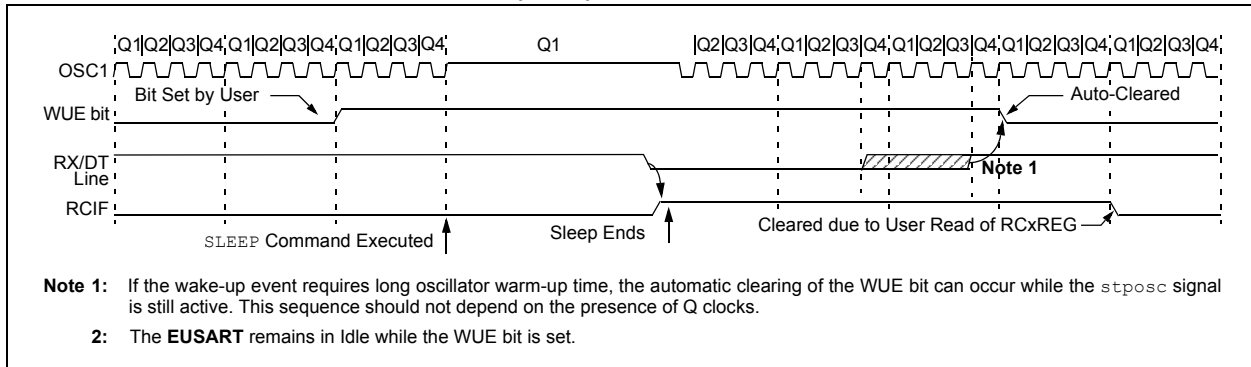
The wake-up event causes a receive interrupt by setting the RCIF bit. The WUE bit is cleared in hardware by a rising edge on RX/DT. The interrupt condition is then cleared in software by reading the RCxREG register and discarding its contents.

To ensure that no actual data is lost, check the RCIDL bit to verify that a receive operation is not in process before setting the WUE bit. If a receive operation is not occurring, the WUE bit may then be set just prior to entering the Sleep mode.

**FIGURE 33-7: AUTO-WAKE-UP BIT (WUE) TIMING DURING NORMAL OPERATION**



**FIGURE 33-8: AUTO-WAKE-UP BIT (WUE) TIMINGS DURING SLEEP**



## 33.4.4 BREAK CHARACTER SEQUENCE

The EUSART module has the capability of sending the special Break character sequences that are required by the LIN bus standard. A Break character consists of a Start bit, followed by 12 '0' bits and a Stop bit.

To send a Break character, set the SENDB and TXEN bits of the TXxSTA register. The Break character transmission is then initiated by a write to the TXxREG. The value of data written to TXxREG will be ignored and all '0's will be transmitted.

The SENDB bit is automatically reset by hardware after the corresponding Stop bit is sent. This allows the user to preload the transmit FIFO with the next transmit byte following the Break character (typically, the Sync character in the LIN specification).

The TRMT bit of the TXxSTA register indicates when the transmit operation is active or Idle, just as it does during normal transmission. See [Figure 33-9](#) for the timing of the Break character sequence.

### 33.4.4.1 Break and Sync Transmit Sequence

The following sequence will start a message frame header made up of a Break, followed by an auto-baud Sync byte. This sequence is typical of a LIN bus master.

1. Configure the EUSART for the desired mode.
2. Set the TXEN and SENDB bits to enable the Break sequence.
3. Load the TXxREG with a dummy character to initiate transmission (the value is ignored).
4. Write '55h' to TXxREG to load the Sync character into the transmit FIFO buffer.
5. After the Break has been sent, the SENDB bit is reset by hardware and the Sync character is then transmitted.

When the TXxREG becomes empty, as indicated by the TXIF, the next data byte can be written to TXxREG.

## 33.4.5 RECEIVING A BREAK CHARACTER

The Enhanced USART module can receive a Break character in two ways.

The first method to detect a Break character uses the FERR bit of the RCxSTA register and the received data as indicated by RCxREG. The Baud Rate Generator is assumed to have been initialized to the expected baud rate.

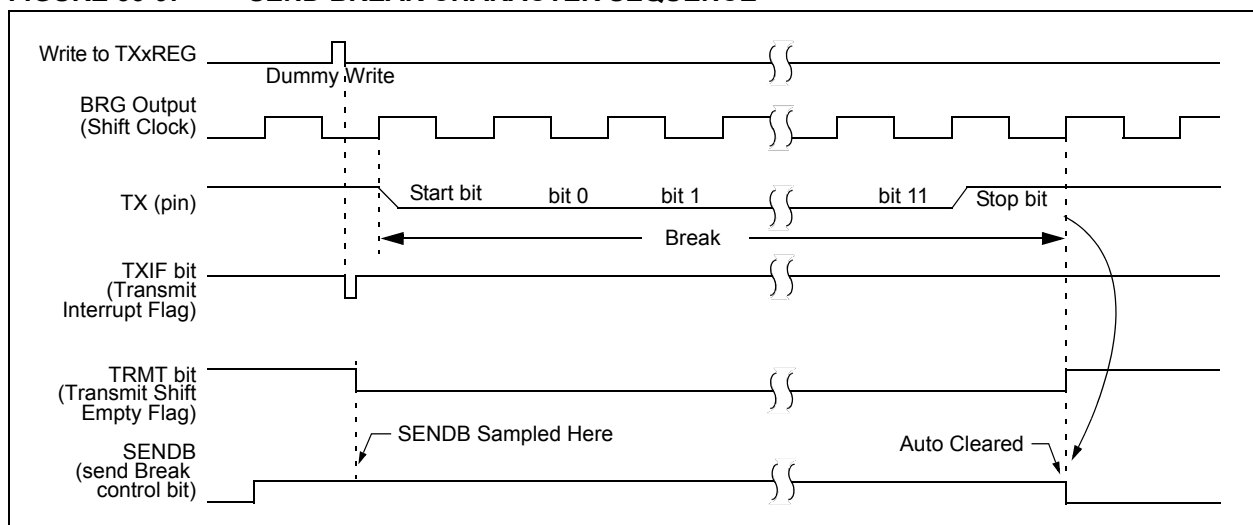
A Break character has been received when;

- RCIF bit is set
- FERR bit is set
- RCxREG = 00h

The second method uses the auto-wake-up feature described in [Section 33.4.3 "Auto-Wake-up on Break"](#). By enabling this feature, the EUSART will sample the next two transitions on RX/DT, cause an RCIF interrupt and receive the next data byte followed by another interrupt.

Note that following a Break character, the user will typically want to enable the Auto-Baud Detect feature. For both methods, the user can set the ABDEN bit of the BAUDxCON register before placing the EUSART in Sleep mode.

**FIGURE 33-9: SEND BREAK CHARACTER SEQUENCE**



## 33.5 EUSART Synchronous Mode

Synchronous serial communications are typically used in systems with a single master and one or more slaves. The master device contains the necessary circuitry for baud rate generation and supplies the clock for all devices in the system. Slave devices can take advantage of the master clock by eliminating the internal clock generation circuitry.

There are two signal lines in Synchronous mode: a bidirectional data line and a clock line. Slaves use the external clock supplied by the master to shift the serial data into and out of their respective receive and transmit shift registers. Since the data line is bidirectional, synchronous operation is half-duplex only. Half-duplex refers to the fact that master and slave devices can receive and transmit data, but not both simultaneously. The EUSART can operate as either a master or slave device.

Start and Stop bits are not used in synchronous transmissions.

### 33.5.1 SYNCHRONOUS MASTER MODE

The following bits are used to configure the EUSART for synchronous master operation:

- SYNC = 1
- CSRC = 1
- SREN = 0 (for transmit); SREN = 1 (for receive)
- CREN = 0 (for transmit); CREN = 1 (for receive)
- SPEN = 1

Setting the SYNC bit of the TXxSTA register configures the device for synchronous operation. Setting the CSRC bit of the TXxSTA register configures the device as a master. Clearing the SREN and CREN bits of the RCxSTA register ensures that the device is in the Transmit mode, otherwise the device will be configured to receive. Setting the SPEN bit of the RCxSTA register enables the EUSART.

#### 33.5.1.1 Master Clock

Synchronous data transfers use a separate clock line, which is synchronous with the data. A device configured as a master transmits the clock on the TX/CK line. The TX/CK pin output driver is automatically enabled when the EUSART is configured for synchronous transmit or receive operation. Serial data bits change on the leading edge to ensure they are valid at the trailing edge of each clock. One clock cycle is generated for each data bit. Only as many clock cycles are generated as there are data bits.

#### 33.5.1.2 Clock Polarity

A clock polarity option is provided for Microwire compatibility. Clock polarity is selected with the SCKP bit of the BAUDxCON register. Setting the SCKP bit sets the clock Idle state as high. When the SCKP bit is set, the data changes on the falling edge of each clock. Clearing the SCKP bit sets the Idle state as low. When the SCKP bit is cleared, the data changes on the rising edge of each clock.

#### 33.5.1.3 Synchronous Master Transmission

Data is transferred out of the device on the RX/DT pin. The RX/DT and TX/CK pin output drivers are automatically enabled when the EUSART is configured for synchronous master transmit operation.

A transmission is initiated by writing a character to the TXxREG register. If the TSR still contains all or part of a previous character the new character data is held in the TXxREG until the last bit of the previous character has been transmitted. If this is the first character, or the previous character has been completely flushed from the TSR, the data in the TXxREG is immediately transferred to the TSR. The transmission of the character commences immediately following the transfer of the data to the TSR from the TXxREG.

Each data bit changes on the leading edge of the master clock and remains valid until the subsequent leading clock edge.

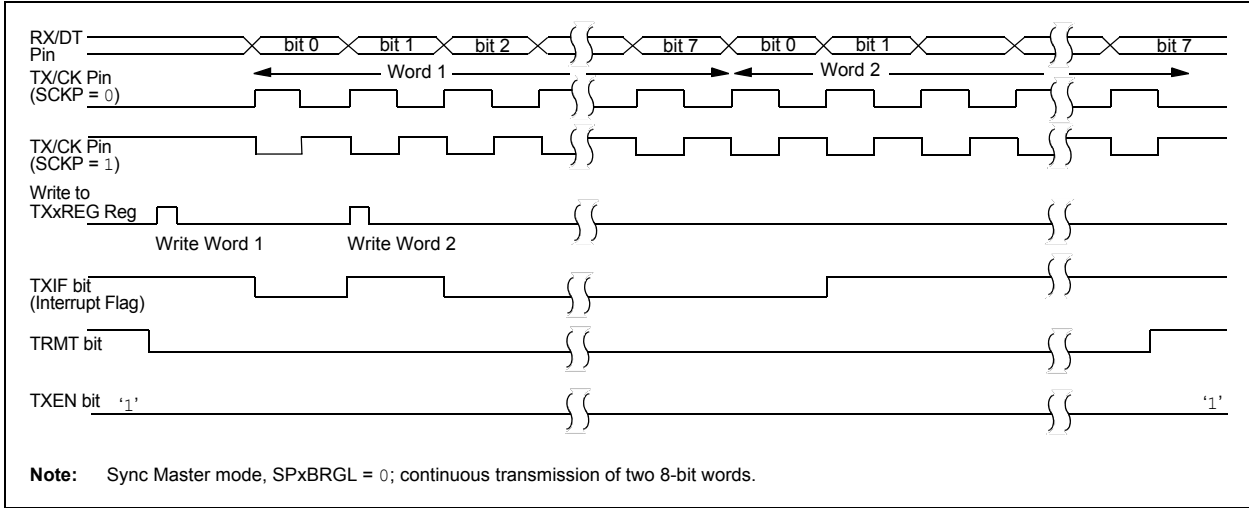
**Note:** The TSR register is not mapped in data memory, so it is not available to the user.

#### 33.5.1.4 Synchronous Master Transmission Setup

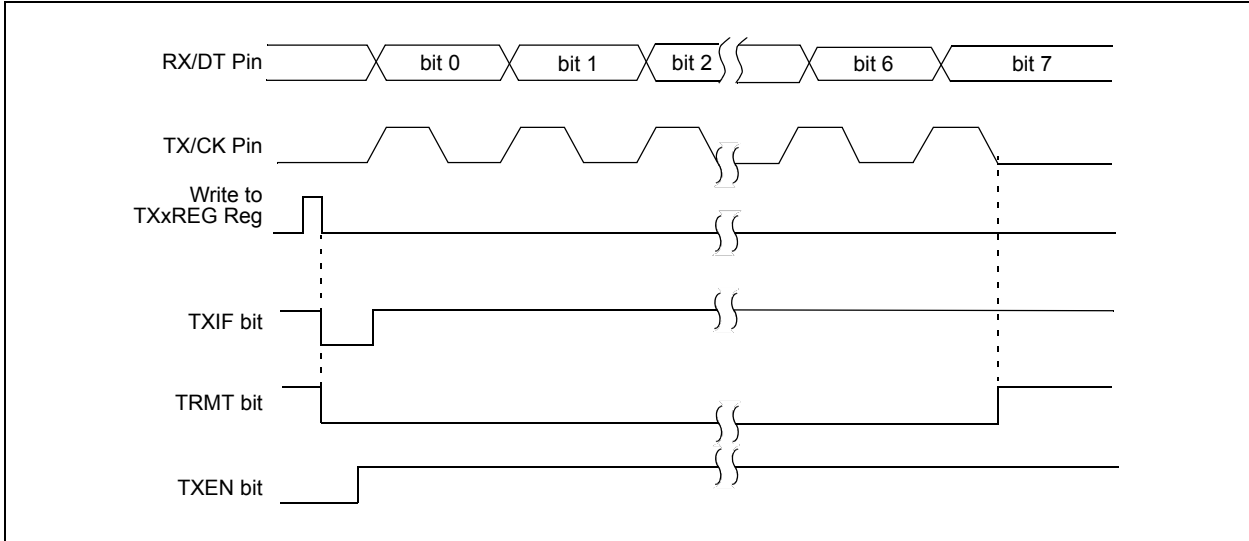
1. Initialize the SPxBRGH, SPxBRGL register pair and the BRGH and BRG16 bits to achieve the desired baud rate (see [Section 33.4 “EUSART Baud Rate Generator \(BRG\)”](#)).
2. Enable the synchronous master serial port by setting bits, SYNC, SPEN and CSRC.
3. Disable Receive mode by clearing bits, SREN and CREN.
4. Enable Transmit mode by setting the TXEN bit.
5. If 9-bit transmission is desired, set the TX9 bit.
6. If interrupts are desired, set the TXIE bit of the PIE1 register, and the GIE and PEIE bits of the INTCON register.
7. If 9-bit transmission is selected, the ninth bit should be loaded in the TX9D bit.
8. Start transmission by loading data to the TXxREG register.



**FIGURE 33-10: SYNCHRONOUS TRANSMISSION**



**FIGURE 33-11: SYNCHRONOUS TRANSMISSION (THROUGH TXEN)**



**TABLE 33-7: SUMMARY OF REGISTERS ASSOCIATED WITH SYNCHRONOUS MASTER TRANSMISSION**

Name	Bit 7	Bit 6	Bit 5	Bit 4	Bit 3	Bit 2	Bit 1	Bit 0	Register on Page
ANSELA	—	—	—	ANSA4	—	ANSA<2:0>			139
ANSELB <sup>(1)</sup>	ANSB<7:4>				—	—	—	—	145
ANSELC	ANSC<7:6> <sup>(1)</sup>		—	—	ANSC<3:0>				150
BAUD1CON	ABDOVF	RCIDL	—	SCKP	BRG16	—	WUE	ABDEN	446
INTCON	GIE	PEIE	TMR0IE	INTE	IOCIE	TMR0IF	INTF	IOCIF	101
PIE1	TMR1GIE	ADIE	RCIE	TXIE	SSP1IE	CCP1IE	TMR2IE	TMR1IE	102
PIR1	TMR1GIF	ADIF	RCIF	TXIF	SSP1IF	CCP1IF	TMR2IF	TMR1IF	106
RC1STA	SPEN	RX9	SREN	CREN	ADDEN	FERR	OERR	RX9D	445
RxyPPS	—	—	—	RxyPPS<4:0>				156	
SP1BRGL	BRG<7:0>								447
SP1BRGH	BRG<15:8>								447
TRISA	—	—	TRISA<5:4>		— <sup>(2)</sup>	TRISA<2:0>			138
TRISB <sup>(1)</sup>	TRISB<7:4>				—	—	—	—	144
TRISC	TRISC<7:6> <sup>(1)</sup>		TRISC<5:0>						149
TX1REG	EUSART Transmit Data Register								437*
TX1STA	CSRC	TX9	TXEN	SYNC	SEnDB	BRGH	TRMT	TX9D	444

**Legend:** — = unimplemented location, read as '0'. Shaded cells are not used for synchronous master transmission.

\* Page provides register information.

**Note 1:** PIC16(L)F1768/9 only.

**Note 2:** Unimplemented, read as '1'.

## 33.5.1.5 Synchronous Master Reception

Data is received at the RX/DT pin. The RX/DT pin output driver is automatically disabled when the EUSART is configured for synchronous master receive operation.

In Synchronous mode, reception is enabled by setting either the Single Receive Enable bit (SREN of the RCxSTA register) or the Continuous Receive Enable bit (CREN of the RCxSTA register).

When SREN is set and CREN is clear, only as many clock cycles are generated as there are data bits in a single character. The SREN bit is automatically cleared at the completion of one character. When CREN is set, clocks are continuously generated until CREN is cleared. If CREN is cleared in the middle of a character, the CK clock stops immediately and the partial character is discarded. If SREN and CREN are both set, then SREN is cleared at the completion of the first character and CREN takes precedence.

To initiate reception, set either SREN or CREN. Data is sampled at the RX/DT pin on the trailing edge of the TX/CK clock pin and is shifted into the Receive Shift Register (RSR). When a complete character is received into the RSR, the RCIF bit is set and the character is automatically transferred to the two-character receive FIFO. The Least Significant eight bits of the top character in the receive FIFO are available in RCxREG. The RCIF bit remains set as long as there are unread characters in the receive FIFO.

**Note:** If the RX/DT function is on an analog pin, the corresponding ANSELx bit must be cleared for the receiver to function.

## 33.5.1.6 Slave Clock

Synchronous data transfers use a separate clock line, which is synchronous with the data. A device configured as a slave receives the clock on the TX/CK line. The TX/CK pin output driver is automatically disabled when the device is configured for synchronous slave transmit or receive operation. Serial data bits change on the leading edge to ensure they are valid at the trailing edge of each clock. One data bit is transferred for each clock cycle. Only as many clock cycles should be received as there are data bits.

**Note:** If the device is configured as a slave and the TX/CK function is on an analog pin, the corresponding ANSELx bit must be cleared.

## 33.5.1.7 Receive Overrun Error

The receive FIFO buffer can hold two characters. An overrun error will be generated if a third character, in its entirety, is received before RCxREG is read to access the FIFO. When this happens, the OERR bit of the RCxSTA register is set. Previous data in the FIFO will not be overwritten. The two characters in the FIFO buffer can be read, however, no additional characters will be received until the error is cleared. The OERR bit can only be cleared by clearing the overrun condition. If the overrun error occurred when the SREN bit is set and CREN is clear, then the error is cleared by reading RCxREG. If the overrun occurred when the CREN bit is set, then the error condition is cleared by either clearing the CREN bit of the RCxSTA register or by clearing the SPEN bit which resets the EUSART.

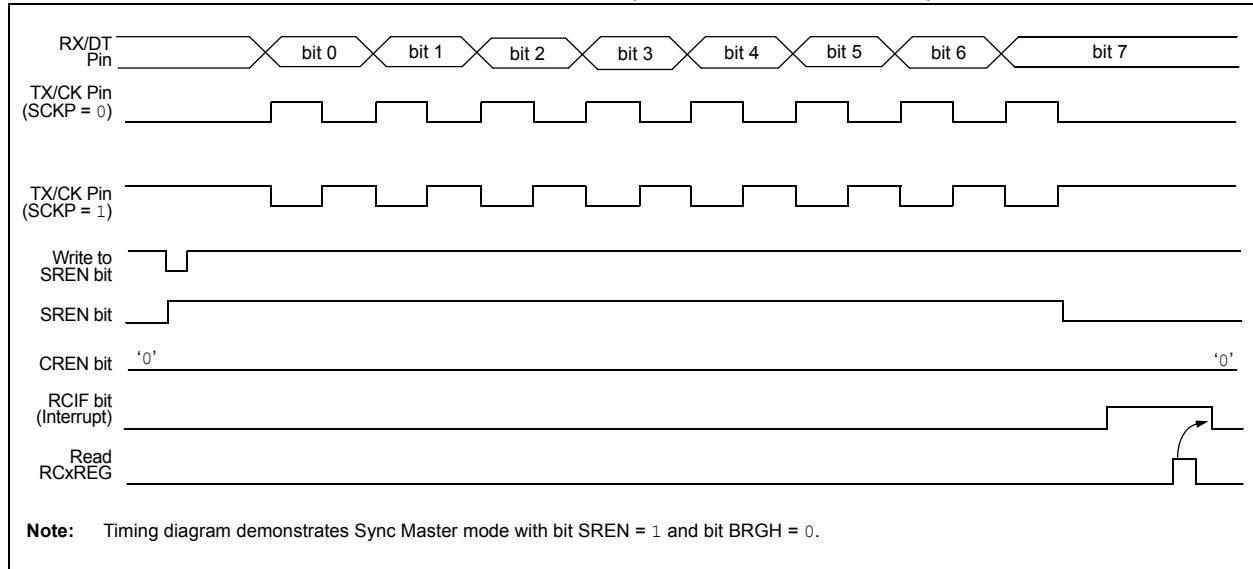
## 33.5.1.8 Receiving 9-Bit Characters

The EUSART supports 9-bit character reception. When the RX9 bit of the RCxSTA register is set the EUSART will shift nine bits into the RSR for each character received. The RX9D bit of the RCxSTA register is the ninth, and Most Significant, data bit of the top unread character in the receive FIFO. When reading 9-bit data from the receive FIFO buffer, the RX9D data bit must be read before reading the eight Least Significant bits from the RCxREG.

## 33.5.1.9 Synchronous Master Reception Setup

1. Initialize the SPxBRGH, SPxBRGL register pair for the appropriate baud rate. Set or clear the BRGH and BRG16 bits, as required, to achieve the desired baud rate.
2. Clear the ANSELx bit for the RX pin (if applicable).
3. Enable the synchronous master serial port by setting bits, SYNC, SPEN and CSRC.
4. Ensure bits, CREN and SREN, are clear.
5. If interrupts are desired, set the RCIE bit of the PIE1 register, and the GIE and PEIE bits of the INTCON register.
6. If 9-bit reception is desired, set bit, RX9.
7. Start reception by setting the SREN bit, or for continuous reception, set the CREN bit.
8. Interrupt flag bit, RCIF, will be set when reception of a character is complete. An interrupt will be generated if the enable bit, RCIE, was set.
9. Read the RCxSTA register to get the ninth bit (if enabled) and determine if any error occurred during reception.
10. Read the 8-bit received data by reading the RCxREG register.
11. If an overrun error occurs, clear the error by either clearing the CREN bit of the RCxSTA register or by clearing the SPEN bit which resets the EUSART.

**FIGURE 33-12: SYNCHRONOUS RECEPTION (MASTER MODE, SREN)**



**TABLE 33-8: SUMMARY OF REGISTERS ASSOCIATED WITH SYNCHRONOUS MASTER RECEPTION**

Name	Bit 7	Bit 6	Bit 5	Bit 4	Bit 3	Bit 2	Bit 1	Bit 0	Register on Page
ANSELA	—	—	—	ANSA4	—	ANSA<2:0>			139
ANSELB <sup>(1)</sup>	ANSB<7:4>				—	—	—	—	145
ANSELC	ANSC<7:6> <sup>(1)</sup>		—	—	ANSC<3:0>				150
BAUD1CON	ABDOVF	RCIDL	—	SCKP	BRG16	—	WUE	ABDEN	446
CKPPS	—	—	—	CKPPS<4:0>				156, 158	
INTCON	GIE	PEIE	TMR0IE	INTE	IOCF	TMR0IF	INTF	IOCF	101
PIE1	TMR1GIE	ADIE	RCIE	TXIE	SSP1IE	CCP1IE	TMR2IE	TMR1IE	102
PIR1	TMR1GIF	ADIF	RCIF	TXIF	SSP1IF	CCP1IF	TMR2IF	TMR1IF	106
RC1REG	EUSART Receive Data Register								440*
RC1STA	SPEN	RX9	SREN	CREN	ADDEN	FERR	OERR	RX9D	445
RXPPS	—	—	—	RXPPS<4:0>				156, 158	
RxyPPS	—	—	—	RxyPPS<4:0>				156	
SP1BRGL	BRG<7:0>								447*
SP1BRGH	BRG<15:8>								447*
TRISA	—	—	TRISA<5:4>		— <sup>(2)</sup>	TRISA<2:0>			138
TRISB <sup>(1)</sup>	TRISB<7:4>				—	—	—	—	144
TRISC	TRISC<7:6> <sup>(1)</sup>			TRISC<5:0>					149
TX1STA	CSRC	TX9	TXEN	SYNC	SENDB	BRGH	TRMT	TX9D	444

**Legend:** — = unimplemented location, read as '0'. Shaded cells are not used for synchronous master reception.

\* Page provides register information.

**Note 1:** PIC16(L)F1768/9 only.

**Note 2:** Unimplemented, read as '1'.

## 33.5.2 SYNCHRONOUS SLAVE MODE

The following bits are used to configure the EUSART for synchronous slave operation:

- SYNC = 1
- CSRC = 0
- SREN = 0 (for transmit); SREN = 1 (for receive)
- CREN = 0 (for transmit); CREN = 1 (for receive)
- SPEN = 1

Setting the SYNC bit of the TXxSTA register configures the device for synchronous operation. Clearing the CSRC bit of the TXxSTA register configures the device as a slave. Clearing the SREN and CREN bits of the RCxSTA register ensures that the device is in the Transmit mode, otherwise the device will be configured to receive. Setting the SPEN bit of the RCxSTA register enables the EUSART.

### 33.5.2.1 EUSART Synchronous Slave Transmit

The operation of the Synchronous Master and Slave modes are identical (see [Section 33.5.1.3 “Synchronous Master Transmission”](#)), except in the case of Sleep mode.

If two words are written to the TXxREG and then the SLEEP instruction is executed, the following will occur:

1. The first character will immediately transfer to the TSR register and transmit.
2. The second word will remain in the TXxREG register.
3. The TXIF bit will not be set.
4. After the first character has been shifted out of TSR, the TXxREG register will transfer the second character to the TSR and the TXIF bit will now be set.
5. If the PEIE and TXIE bits are set, the interrupt will wake the device from Sleep and execute the next instruction. If the GIE bit is also set, the program will call the Interrupt Service Routine.

### 33.5.2.2 Synchronous Slave Transmission Setup

1. Set the SYNC and SPEN bits, and clear the CSRC bit.
2. Clear the ANSEL bit for the CK pin (if applicable).
3. Clear the CREN and SREN bits.
4. If interrupts are desired, set the TXIE bit of the PIE1 register, and the GIE and PEIE bits of the INTCON register.
5. If 9-bit transmission is desired, set the TX9 bit.
6. Enable transmission by setting the TXEN bit.
7. If 9-bit transmission is selected, insert the Most Significant bit into the TX9D bit.
8. Start transmission by writing the Least Significant eight bits to the TXxREG register.

**TABLE 33-9: SUMMARY OF REGISTERS ASSOCIATED WITH SYNCHRONOUS SLAVE TRANSMISSION**

Name	Bit 7	Bit 6	Bit 5	Bit 4	Bit 3	Bit 2	Bit 1	Bit 0	Register on Page
ANSELA	—	—	—	ANSA4	—	ANSA<2:0>			139
ANSELB <sup>(1)</sup>	ANSB<7:4>				—	—	—	—	145
ANSELC	ANSC<7:6> <sup>(1)</sup>		—	—	ANSC<3:0>				150
BAUD1CON	ABDOVF	RCIDL	—	SCKP	BRG16	—	WUE	ABDEN	446
CKPPS	—	—	—	CKPPS<4:0>					156, 158
INTCON	GIE	PEIE	TMR0IE	INTE	IOCF	TMR0IF	INTF	IOCF	101
PIE1	TMR1GIE	ADIE	RCIE	TXIE	SSP1IE	CCP1IE	TMR2IE	TMR1IE	102
PIR1	TMR1GIF	ADIF	RCIF	TXIF	SSP1IF	CCP1IF	TMR2IF	TMR1IF	106
RC1STA	SPEN	RX9	SREN	CREN	ADDEN	FERR	OERR	RX9D	445
RXPPS	—	—	—	RXPPS<4:0>					156, 158
RxyPPS	—	—	—	RxyPPS<4:0>					156
TRISA	—	—	TRISA<5:4>		— <sup>(2)</sup>	TRISA<2:0>			138
TRISB <sup>(1)</sup>	TRISB<7:4>				—	—	—	—	144
TRISC	TRISC<7:6> <sup>(1)</sup>		TRISC<5:0>						149
TX1REG	EUSART Transmit Data Register								437*
TX1STA	CSRC	TX9	TXEN	SYNC	SEnDB	BRGH	TRMT	TX9D	444

**Legend:** — = unimplemented location, read as '0'. Shaded cells are not used for synchronous slave transmission.

\* Page provides register information.

**Note 1:** PIC16(L)F1768/9 only.

**Note 2:** Unimplemented, read as '1'.

## 33.5.2.3 EUSART Synchronous Slave Reception

The operation of the Synchronous Master and Slave modes is identical ([Section 33.5.1.5 “Synchronous Master Reception”](#)), with the following exceptions:

- Sleep
- CREN bit is always set, therefore the receiver is never Idle
- SREN bit, which is a “don’t care” in Slave mode

A character may be received while in Sleep mode by setting the CREN bit prior to entering Sleep. Once the word is received, the RSR register will transfer the data to the RCxREG register. If the RCIE enable bit is set, the interrupt generated will wake the device from Sleep and execute the next instruction. If the GIE bit is also set, the program will branch to the interrupt vector.

## 33.5.2.4 Synchronous Slave Reception Setup

1. Set the SYNC and SPEN bits, and clear the CSRC bit.
2. Clear the ANSELx bit for both the CK and DT pins (if applicable).
3. If interrupts are desired, set the RCIE bit of the PIE1 register, and the GIE and PEIE bits of the INTCON register.
4. If 9-bit reception is desired, set the RX9 bit.
5. Set the CREN bit to enable reception.
6. The RCIF bit will be set when reception is complete. An interrupt will be generated if the RCIE bit was set.
7. If 9-bit mode is enabled, retrieve the Most Significant bit from the RX9D bit of the RCxSTA register.
8. Retrieve the eight Least Significant bits from the receive FIFO by reading the RCxREG register.
9. If an overrun error occurs, clear the error by either clearing the CREN bit of the RCxSTA register or by clearing the SPEN bit which resets the EUSART.

**TABLE 33-10: SUMMARY OF REGISTERS ASSOCIATED WITH SYNCHRONOUS SLAVE RECEPTION**

Name	Bit 7	Bit 6	Bit 5	Bit 4	Bit 3	Bit 2	Bit 1	Bit 0	Register on Page
ANSELA	—	—	—	ANSA4	—	ANSA<2:0>			139
ANSELB <sup>(1)</sup>	ANSB<7:4>				—	—	—	—	145
ANSELC	ANSC<7:6> <sup>(1)</sup>		—	—	ANSC<3:0>				150
BAUD1CON	ABDOVF	RCIDL	—	SCKP	BRG16	—	WUE	ABDEN	446
CKPPS	—	—	—	CKPPS<4:0>				156, 158	
INTCON	GIE	PEIE	TMR0IE	INTE	IOCIE	TMR0IF	INTF	IOCIF	101
PIE1	TMR1GIE	ADIE	RCIE	TXIE	SSP1IE	CCP1IE	TMR2IE	TMR1IE	102
PIR1	TMR1GIF	ADIF	RCIF	TXIF	SSP1IF	CCP1IF	TMR2IF	TMR1IF	106
RC1REG	EUSART Receive Data Register								440*
RC1STA	SPEN	RX9	SREN	CREN	ADDEN	FERR	OERR	RX9D	445
RXPPS	—	—	—	RXPPS<4:0>				156, 158	
TRISA	—	—	TRISA<5:4>		— <sup>(2)</sup>	TRISA<2:0>			138
TRISB <sup>(1)</sup>	TRISB<7:4>				—	—	—	—	144
TRISC	TRISC<7:6> <sup>(1)</sup>		TRISC<5:0>						149
TX1STA	CSRC	TX9	TXEN	SYNC	SENDB	BRGH	TRMT	TX9D	444

**Legend:** — = unimplemented location, read as ‘0’. Shaded cells are not used for synchronous slave reception.

\* Page provides register information.

**Note 1:** PIC16(L)F1768/9 only.

**Note 2:** Unimplemented, read as ‘1’.

## 33.6 EUSART Operation During Sleep

The EUSART will remain active during Sleep only in the Synchronous Slave mode. All other modes require the system clock and therefore, cannot generate the necessary signals to run the Transmit or Receive Shift registers during Sleep.

Synchronous Slave mode uses an externally generated clock to run the Transmit and Receive Shift registers.

### 33.6.1 SYNCHRONOUS RECEIVE DURING SLEEP

To receive during Sleep, all the following conditions must be met before entering Sleep mode:

- RCxSTA and TXxSTA Control registers must be configured for synchronous slave reception (see [Section 33.5.2.4 “Synchronous Slave Reception Setup”](#)).
- If interrupts are desired, set the RCIE bit of the PIE1 register, and the GIE and PEIE bits of the INTCON register.
- The RCIF interrupt flag must be cleared by reading RCxREG to unload any pending characters in the receive buffer.

Upon entering Sleep mode, the device will be ready to accept data and clocks on the RX/DT and TX/CK pins, respectively. When the data word has been completely clocked in by the external device, the RCIF interrupt flag bit of the PIR1 register will be set; thereby, waking the processor from Sleep.

Upon waking from Sleep, the instruction following the SLEEP instruction will be executed. If the Global Interrupt Enable (GIE) bit of the INTCON register is also set, then the Interrupt Service Routine at address, 004h, will be called.

### 33.6.2 SYNCHRONOUS TRANSMIT DURING SLEEP

To transmit during Sleep, all the following conditions must be met before entering Sleep mode:

- The RCxSTA and TXxSTA Control registers must be configured for synchronous slave transmission (see [Section 33.5.2.2 “Synchronous Slave Transmission Setup”](#)).
- The TXIF interrupt flag must be cleared by writing the output data to the TXxREG; thereby, filling the TSR and transmit buffer.
- If interrupts are desired, set the TXIE bit of the PIE1 register and the PEIE bit of the INTCON register.
- Interrupt enable bits, TXIE of the PIE1 register and PEIE of the INTCON register, must set.

Upon entering Sleep mode, the device will be ready to accept clocks on the TX/CK pin and transmit data on the RX/DT pin. When the data word in the TSR has been completely clocked out by the external device, the pending byte in the TXxREG will transfer to the TSR and the TXIF flag will be set; thereby, waking the processor from Sleep. At this point, the TXxREG is available to accept another character for transmission, which will clear the TXIF flag.

Upon waking from Sleep, the instruction following the SLEEP instruction will be executed. If the Global Interrupt Enable (GIE) bit is also set, then the Interrupt Service Routine at address, 0004h, will be called.



## 34.0 IN-CIRCUIT SERIAL PROGRAMMING™ (ICSP™)

ICSP™ programming allows customers to manufacture circuit boards with unprogrammed devices. Programming can be done after the assembly process, allowing the device to be programmed with the most recent firmware or a custom firmware. Five pins are needed for ICSP™ programming:

- ICSPCLK
- ICSPDAT
- MCLR/VPP
- VDD
- VSS

In Program/Verify mode, the program memory, User IDs and the Configuration Words are programmed through serial communications. The ICSPDAT pin is a bidirectional I/O used for transferring the serial data and the ICSPCLK pin is the clock input. For more information on ICSP™ refer to the “PIC16(L)F170X Memory Programming Specification” (DS40001683).

### 34.1 High-Voltage Programming Entry Mode

The device is placed into High-Voltage Programming Entry mode by holding the ICSPCLK and ICSPDAT pins low, then raising the voltage on MCLR/VPP to VIH.

### 34.2 Low-Voltage Programming Entry Mode

The Low-Voltage Programming Entry mode allows the PIC® Flash MCUs to be programmed using VDD only, without high voltage. When the LVP bit of Configuration Words is set to ‘1’, the low-voltage ICSP programming entry is enabled. To disable the Low-Voltage ICSP mode, the LVP bit must be programmed to ‘0’.

Entry into the Low-Voltage Programming Entry mode requires the following steps:

1.  $\overline{\text{MCLR}}$  is brought to  $V_{IL}$ .
2. A 32-bit key sequence is presented on ICSPDAT, while clocking ICSPCLK.

Once the key sequence is complete,  $\overline{\text{MCLR}}$  must be held at  $V_{IL}$  for as long as Program/Verify mode is to be maintained.

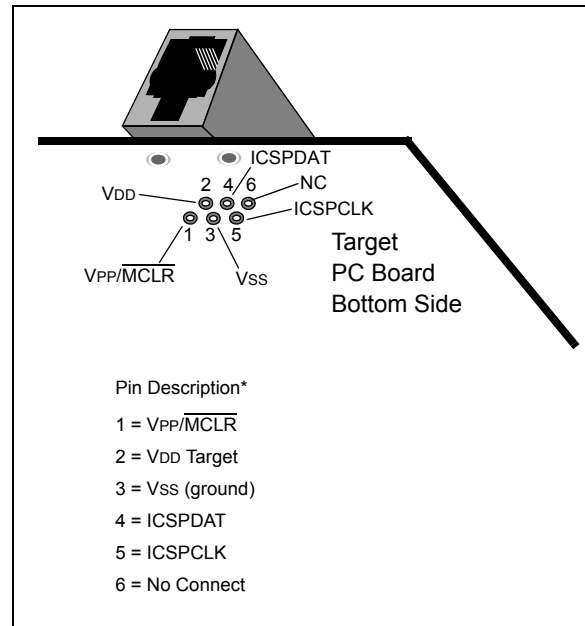
If Low-Voltage Programming mode is enabled ( $\text{LVP} = 1$ ), the  $\overline{\text{MCLR}}$  Reset function is automatically enabled and cannot be disabled. See [Section 6.5 “MCLR”](#) for more information.

The LVP bit can only be reprogrammed to ‘0’ by using the High-Voltage Programming mode.

## 34.3 Common Programming Interfaces

Connection to a target device is typically done through an ICSP header. A commonly found connector on development tools is the RJ-11 in the 6P6C (6-pin, 6-connector) configuration. See [Figure 34-1](#).

**FIGURE 34-1: ICD RJ-11 STYLE CONNECTOR INTERFACE**

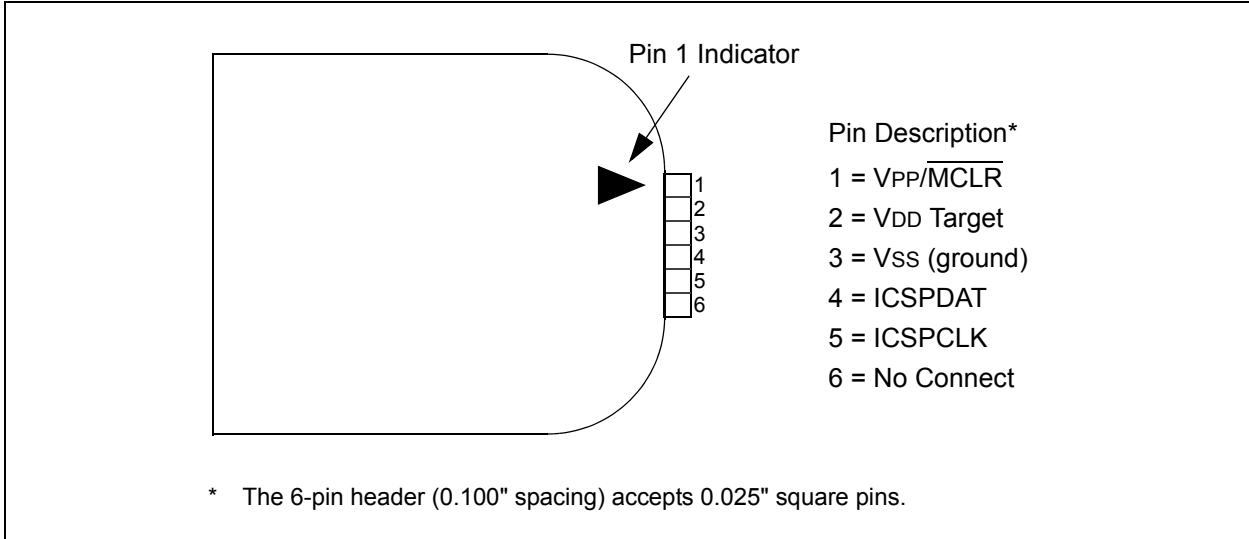


Another connector often found in use with the PICkit™ programmers is a standard 6-pin header with 0.1 inch spacing. Refer to [Figure 34-2](#).

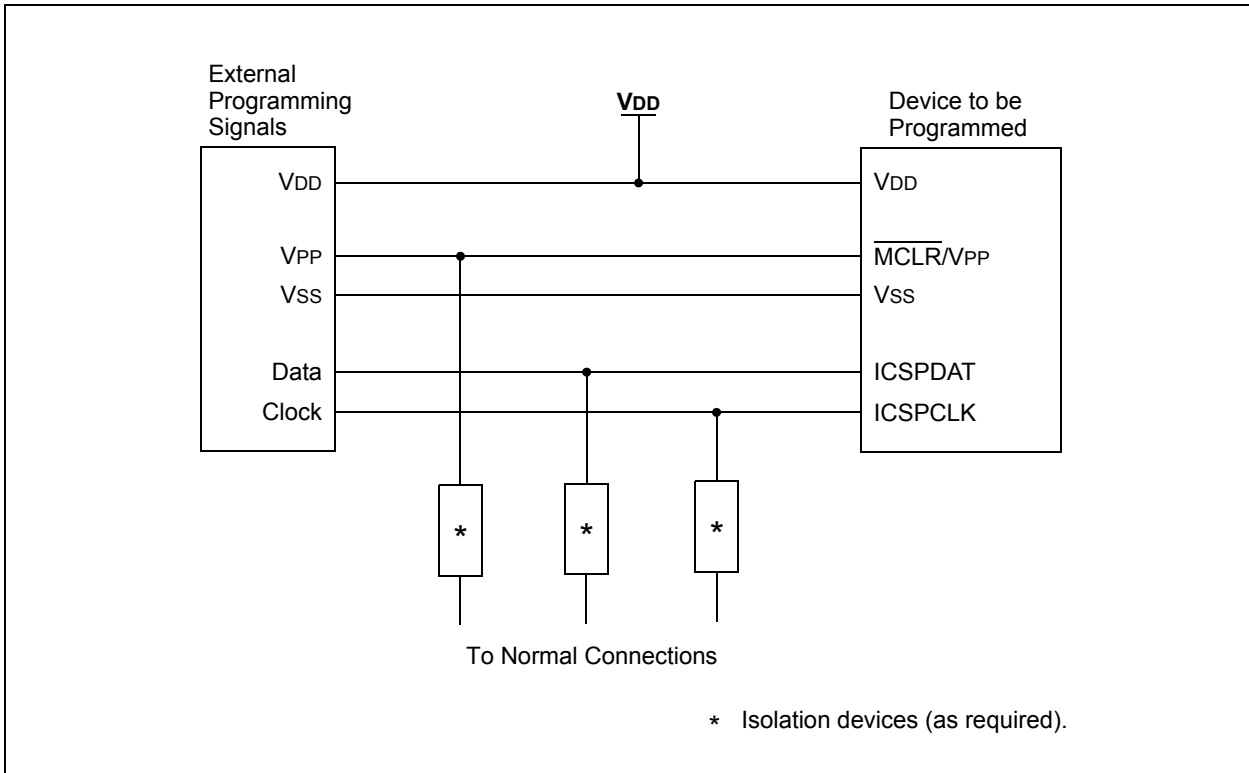
For additional interface recommendations, refer to your specific device programmer manual prior to PCB design.

It is recommended that isolation devices be used to separate the programming pins from other circuitry. The type of isolation is highly dependent on the specific application and may include devices, such as resistors, diodes or even jumpers. See [Figure 34-3](#) for more information.

**FIGURE 34-2: PICKIT™ PROGRAMMER STYLE CONNECTOR INTERFACE**



**FIGURE 34-3: TYPICAL CONNECTION FOR ICSP™ PROGRAMMING**



## 35.0 INSTRUCTION SET SUMMARY

Each instruction is a 14-bit word containing the operation code (opcode) and all required operands. The opcodes are broken into three broad categories.

- Byte Oriented
- Bit Oriented
- Literal and Control

The literal and control category contains the most varied instruction word format.

Table 35-3 lists the instructions recognized by the MPASM™ assembler.

All instructions are executed within a single instruction cycle, with the following exceptions, which may take two or three cycles:

- Subroutine takes two cycles (CALL, CALLW)
- Returns from interrupts or subroutines take two cycles (RETURN, RETLW, RETFIE)
- Program branching takes two cycles (GOTO, BRA, BRW, BTFSS, BTFSC, DECFSZ, INCSFZ)
- One additional instruction cycle will be used when any instruction references an indirect file register and the file select register is pointing to program memory.

One instruction cycle consists of four oscillator cycles; for an oscillator frequency of 4 MHz, this gives a nominal instruction execution rate of 1 MHz.

All instruction examples use the format '0xhh' to represent a hexadecimal number, where 'h' signifies a hexadecimal digit.

## 35.1 Read-Modify-Write Operations

Any instruction that specifies a file register as part of the instruction performs a Read-Modify-Write (R-M-W) operation. The register is read, the data is modified and the result is stored according to either the instruction or the destination designator, 'd'. A read operation is performed on a register even if the instruction writes to that register.

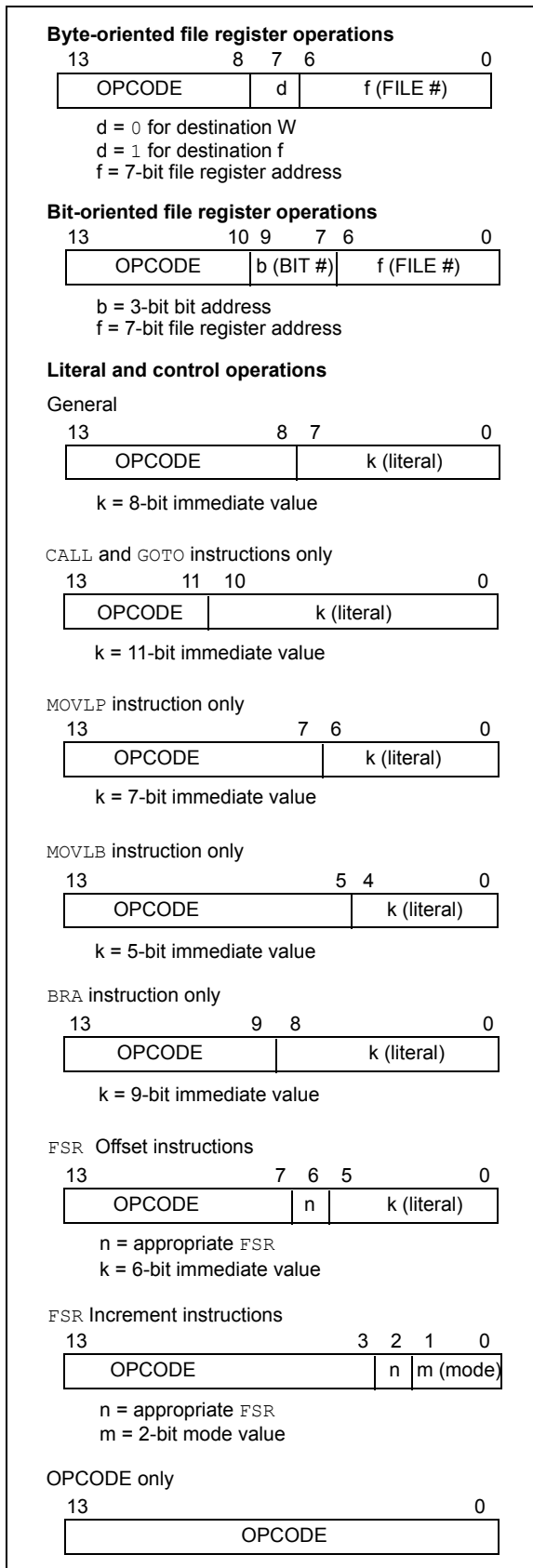
**TABLE 35-1: OPCODE FIELD DESCRIPTIONS**

Field	Description
f	Register file address (0x00 to 0x7F).
W	Working register (accumulator).
b	Bit address within an 8-bit file register.
k	Literal field, constant data or label
x	Don't care location (= 0 or 1). The assembler will generate code with x = 0. It is the recommended form of use for compatibility with all Microchip software tools.
d	Destination select; d = 0: store result in W, d = 1: store result in file register f. Default is d = 1.
n	FSR or INDF number (0-1).
mm	Pre/Post-Increment/Decrement mode selection.

**TABLE 35-2: ABBREVIATION DESCRIPTIONS**

Field	Description
PC	Program Counter
$\overline{TO}$	Time-out bit
C	Carry bit
DC	Digit Carry bit
Z	Zero bit
$\overline{PD}$	Power-Down bit

**FIGURE 35-1: GENERAL FORMAT FOR INSTRUCTIONS**



# PIC16(L)F1764/5/8/9

**TABLE 35-3: PIC16(L)F1764/5/8/9 INSTRUCTION SET**

Mnemonic, Operands	Description	Cycles	14-Bit Opcode				Status Affected	Notes	
			MSb	LSb					
<b>BYTE-ORIENTED FILE REGISTER OPERATIONS</b>									
ADDWF	f, d	Add W and f	1	00	0111	dfff	ffff	C, DC, Z	2
ADDWFC	f, d	Add with Carry W and f	1	11	1101	dfff	ffff	C, DC, Z	2
ANDWF	f, d	AND W with f	1	00	0101	dfff	ffff	Z	2
ASRF	f, d	Arithmetic Right Shift	1	11	0111	dfff	ffff	C, Z	2
LSLF	f, d	Logical Left Shift	1	11	0101	dfff	ffff	C, Z	2
LSRF	f, d	Logical Right Shift	1	11	0110	dfff	ffff	C, Z	2
CLRF	f	Clear f	1	00	0001	1fff	ffff	Z	2
CLRW	–	Clear W	1	00	0001	0000	00xx	Z	
COMF	f, d	Complement f	1	00	1001	dfff	ffff	Z	2
DECf	f, d	Decrement f	1	00	0011	dfff	ffff	Z	2
INCF	f, d	Increment f	1	00	1010	dfff	ffff	Z	2
IORWF	f, d	Inclusive OR W with f	1	00	0100	dfff	ffff	Z	2
MOVF	f, d	Move f	1	00	1000	dfff	ffff	Z	2
MOVWF	f	Move W to f	1	00	0000	1fff	ffff		2
RLF	f, d	Rotate Left f through Carry	1	00	1101	dfff	ffff	C	2
RRF	f, d	Rotate Right f through Carry	1	00	1100	dfff	ffff	C	2
SUBWF	f, d	Subtract W from f	1	00	0010	dfff	ffff	C, DC, Z	2
SUBWFB	f, d	Subtract with Borrow W from f	1	11	1011	dfff	ffff	C, DC, Z	2
SWAPF	f, d	Swap nibbles in f	1	00	1110	dfff	ffff		2
XORWF	f, d	Exclusive OR W with f	1	00	0110	dfff	ffff	Z	2
<b>BYTE ORIENTED SKIP OPERATIONS</b>									
DECFSZ	f, d	Decrement f, Skip if 0	1(2)	00	1011	dfff	ffff		1, 2
INCFSZ	f, d	Increment f, Skip if 0	1(2)	00	1111	dfff	ffff		1, 2
<b>BIT-ORIENTED FILE REGISTER OPERATIONS</b>									
BCF	f, b	Bit Clear f	1	01	00bb	bfff	ffff		2
BSF	f, b	Bit Set f	1	01	01bb	bfff	ffff		2
<b>BIT-ORIENTED SKIP OPERATIONS</b>									
BTFSC	f, b	Bit Test f, Skip if Clear	1 (2)	01	10bb	bfff	ffff		1, 2
BTFSS	f, b	Bit Test f, Skip if Set	1 (2)	01	11bb	bfff	ffff		1, 2
<b>LITERAL OPERATIONS</b>									
ADDLW	k	Add literal and W	1	11	1110	kkkk	kkkk	C, DC, Z	
ANDLW	k	AND literal with W	1	11	1001	kkkk	kkkk	Z	
IORLW	k	Inclusive OR literal with W	1	11	1000	kkkk	kkkk	Z	
MOVLB	k	Move literal to BSR	1	00	0000	001k	kkkk		
MOVLP	k	Move literal to PCLATH	1	11	0001	1kkk	kkkk		
MOVLW	k	Move literal to W	1	11	0000	kkkk	kkkk		
SUBLW	k	Subtract W from literal	1	11	1100	kkkk	kkkk	C, DC, Z	
XORLW	k	Exclusive OR literal with W	1	11	1010	kkkk	kkkk	Z	

- Note 1:** If the Program Counter (PC) is modified, or a conditional test is true, the instruction requires two cycles. The second cycle is executed as a NOP.
- 2:** If this instruction addresses an INDFn register and the MSb of the corresponding FSRn is set, this instruction will require one additional instruction cycle.
- 3:** See [Table 35-3](#) for the MOVW and MOVWI instruction descriptions.

# PIC16(L)F1764/5/8/9

**TABLE 35-3: PIC16(L)F1764/5/8/9 INSTRUCTION SET (CONTINUED)**

Mnemonic, Operands	Description	Cycles	14-Bit Opcode				Status Affected	Notes
			MSb			LSb		
<b>CONTROL OPERATIONS</b>								
BRA	k	Relative Branch	2	11	001k	kkkk	kkkk	
BRW	–	Relative Branch with W	2	00	0000	0000	1011	
CALL	k	Call Subroutine	2	10	0kkk	kkkk	kkkk	
CALLW	–	Call Subroutine with W	2	00	0000	0000	1010	
GOTO	k	Go to address	2	10	1kkk	kkkk	kkkk	
RETFIE	k	Return from interrupt	2	00	0000	0000	1001	
RETLW	k	Return with literal in W	2	11	0100	kkkk	kkkk	
RETURN	–	Return from Subroutine	2	00	0000	0000	1000	
<b>INHERENT OPERATIONS</b>								
CLRWDT	–	Clear Watchdog Timer	1	00	0000	0110	0100	$\overline{TO}, \overline{PD}$
NOP	–	No Operation	1	00	0000	0000	0000	
OPTION	–	Load OPTION_REG register with W	1	00	0000	0110	0010	
RESET	–	Software device Reset	1	00	0000	0000	0001	
SLEEP	–	Go into Standby mode	1	00	0000	0110	0011	$\overline{TO}, \overline{PD}$
TRIS	f	Load TRIS register with W	1	00	0000	0110	0fff	
<b>C-COMPILER OPTIMIZED</b>								
ADDFSR	n, k	Add Literal k to FSRn	1	11	0001	0nkk	kkkk	
MOVIW	n mm	Move Indirect FSRn to W with pre/post inc/dec modifier, mm	1	00	0000	0001	0nmm	Z
	k[n]	Move INDFn to W, Indexed Indirect.	1	11	1111	0nkk	kkkk	Z
MOVWI	n mm	Move W to Indirect FSRn with pre/post inc/dec modifier, mm	1	00	0000	0001	1nmm	
	k[n]	Move W to INDFn, Indexed Indirect.	1	11	1111	1nkk	kkkk	

- Note 1:** If the Program Counter (PC) is modified, or a conditional test is true, the instruction requires two cycles. The second cycle is executed as a NOP.
- 2:** If this instruction addresses an INDFn register and the MSb of the corresponding FSRn is set, this instruction will require one additional instruction cycle.
- 3:** See Table 35-3 for the MOVIW and MOVWI instruction descriptions.

## 35.2 Instruction Descriptions

<b>ADDFSR</b>	<b>Add Literal to FSRn</b>
Syntax:	[ <i>label</i> ] ADDFSR FSRn, k
Operands:	-32 ≤ k ≤ 31 n ∈ [ 0, 1 ]
Operation:	FSR(n) + k → FSR(n)
Status Affected:	None
Description:	The signed 6-bit literal 'k' is added to the contents of the FSRnH:FSRnL register pair.  FSRn is limited to the range 0000h-FFFFh. Moving beyond these bounds will cause the FSRn to wrap around.

<b>ANDLW</b>	<b>AND literal with W</b>
Syntax:	[ <i>label</i> ] ANDLW k
Operands:	0 ≤ k ≤ 255
Operation:	(W) .AND. (k) → (W)
Status Affected:	Z
Description:	The contents of W register are AND'ed with the 8-bit literal 'k'. The result is placed in the W register.

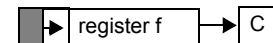
<b>ADDLW</b>	<b>Add literal and W</b>
Syntax:	[ <i>label</i> ] ADDLW k
Operands:	0 ≤ k ≤ 255
Operation:	(W) + k → (W)
Status Affected:	C, DC, Z
Description:	The contents of the W register are added to the 8-bit literal 'k' and the result is placed in the W register.

<b>ANDWF</b>	<b>AND W with f</b>
Syntax:	[ <i>label</i> ] ANDWF f,d
Operands:	0 ≤ f ≤ 127 d ∈ [0,1]
Operation:	(W) .AND. (f) → (destination)
Status Affected:	Z
Description:	AND the W register with register 'f'. If 'd' is '0', the result is stored in the W register. If 'd' is '1', the result is stored back in register 'f'.

<b>ADDWF</b>	<b>Add W and f</b>
Syntax:	[ <i>label</i> ] ADDWF f,d
Operands:	0 ≤ f ≤ 127 d ∈ [0,1]
Operation:	(W) + (f) → (destination)
Status Affected:	C, DC, Z
Description:	Add the contents of the W register with register 'f'. If 'd' is '0', the result is stored in the W register. If 'd' is '1', the result is stored back in register 'f'.

<b>ASRF</b>	<b>Arithmetic Right Shift</b>
Syntax:	[ <i>label</i> ] ASRF f {,d}
Operands:	0 ≤ f ≤ 127 d ∈ [0,1]
Operation:	(f<7>) → dest<7> (f<7:1>) → dest<6:0>, (f<0>) → C,
Status Affected:	C, Z
Description:	The contents of register 'f' are shifted one bit to the right through the Carry flag. The MSb remains unchanged. If 'd' is '0', the result is placed in W. If 'd' is '1', the result is stored back in register 'f'.

<b>ADDWFC</b>	<b>ADD W and CARRY bit to f</b>
Syntax:	[ <i>label</i> ] ADDWFC f {,d}
Operands:	0 ≤ f ≤ 127 d ∈ [0,1]
Operation:	(W) + (f) + (C) → dest
Status Affected:	C, DC, Z
Description:	Add W, the Carry flag and data memory location 'f'. If 'd' is '0', the result is placed in W. If 'd' is '1', the result is placed in data memory location 'f'.



<b>BCF</b>	<b>Bit Clear f</b>
Syntax:	[ <i>label</i> ] BCF f,b
Operands:	$0 \leq f \leq 127$ $0 \leq b \leq 7$
Operation:	$0 \rightarrow (f<b>)$
Status Affected:	None
Description:	Bit 'b' in register 'f' is cleared.

<b>BTFSK</b>	<b>Bit Test f, Skip if Clear</b>
Syntax:	[ <i>label</i> ] BTFSK f,b
Operands:	$0 \leq f \leq 127$ $0 \leq b \leq 7$
Operation:	skip if (f<b>) = 0
Status Affected:	None
Description:	If bit 'b' in register 'f' is '1', the next instruction is executed. If bit 'b', in register 'f', is '0', the next instruction is discarded, and a NOP is executed instead, making this a 2-cycle instruction.

<b>BRA</b>	<b>Relative Branch</b>
Syntax:	[ <i>label</i> ] BRA label [ <i>label</i> ] BRA \$+k
Operands:	$-256 \leq \text{label} - \text{PC} + 1 \leq 255$ $-256 \leq k \leq 255$
Operation:	$(\text{PC}) + 1 + k \rightarrow \text{PC}$
Status Affected:	None
Description:	Add the signed 9-bit literal 'k' to the PC. Since the PC will have incremented to fetch the next instruction, the new address will be $\text{PC} + 1 + k$ . This instruction is a 2-cycle instruction. This branch has a limited range.

<b>BTFSF</b>	<b>Bit Test f, Skip if Set</b>
Syntax:	[ <i>label</i> ] BTFSF f,b
Operands:	$0 \leq f \leq 127$ $0 \leq b < 7$
Operation:	skip if (f<b>) = 1
Status Affected:	None
Description:	If bit 'b' in register 'f' is '0', the next instruction is executed. If bit 'b' is '1', then the next instruction is discarded and a NOP is executed instead, making this a 2-cycle instruction.

<b>BRW</b>	<b>Relative Branch with W</b>
Syntax:	[ <i>label</i> ] BRW
Operands:	None
Operation:	$(\text{PC}) + (W) \rightarrow \text{PC}$
Status Affected:	None
Description:	Add the contents of W (unsigned) to the PC. Since the PC will have incremented to fetch the next instruction, the new address will be $\text{PC} + 1 + (W)$ . This instruction is a 2-cycle instruction.

<b>BSF</b>	<b>Bit Set f</b>
Syntax:	[ <i>label</i> ] BSF f,b
Operands:	$0 \leq f \leq 127$ $0 \leq b \leq 7$
Operation:	$1 \rightarrow (f<b>)$
Status Affected:	None
Description:	Bit 'b' in register 'f' is set.



# PIC16(L)F1764/5/8/9

---

**CALL**                      **Call Subroutine**

---

Syntax:                      [ *label* ] CALL *k*  
Operands:                     $0 \leq k \leq 2047$   
Operation:                    (PC)+ 1 → TOS,  
                                  *k* → PC<10:0>,  
                                  (PCLATH<6:3>) → PC<14:11>  
Status Affected:            None  
Description:                Call Subroutine. First, return address (PC + 1) is pushed onto the stack. The 11-bit immediate address is loaded into PC bits<10:0>. The upper bits of the PC are loaded from PCLATH. CALL is a 2-cycle instruction.

---

**CLRWDT**                    **Clear Watchdog Timer**

---

Syntax:                      [ *label* ] CLRWDT  
Operands:                    None  
Operation:                    00h → WDT  
                                  0 → WDT prescaler,  
                                  1 →  $\overline{TO}$   
                                  1 →  $\overline{PD}$   
Status Affected:             $\overline{TO}$ ,  $\overline{PD}$   
Description:                CLRWDT instruction resets the Watchdog Timer. It also resets the prescaler of the WDT. Status bits  $\overline{TO}$  and  $\overline{PD}$  are set.

---

**CALLW**                    **Subroutine Call With W**

---

Syntax:                      [ *label* ] CALLW  
Operands:                    None  
Operation:                    (PC) + 1 → TOS,  
                                  (*W*) → PC<7:0>,  
                                  (PCLATH<6:0>) → PC<14:8>  
Status Affected:            None  
Description:                Subroutine call with W. First, the return address (PC + 1) is pushed onto the return stack. Then, the contents of W are loaded into PC<7:0>, and the contents of PCLATH into PC<14:8>. CALLW is a 2-cycle instruction.

---

**COMF**                      **Complement f**

---

Syntax:                      [ *label* ] COMF *f*,*d*  
Operands:                     $0 \leq f \leq 127$   
                                  *d* ∈ [0,1]  
Operation:                    ( $\bar{f}$ ) → (destination)  
Status Affected:            Z  
Description:                The contents of register 'f' are complemented. If 'd' is '0', the result is stored in W. If 'd' is '1', the result is stored back in register 'f'.

---

**CLRF**                      **Clear f**

---

Syntax:                      [ *label* ] CLRF *f*  
Operands:                     $0 \leq f \leq 127$   
Operation:                    00h → (*f*)  
                                  1 → Z  
Status Affected:            Z  
Description:                The contents of register 'f' are cleared and the Z bit is set.

---

**DECF**                      **Decrement f**

---

Syntax:                      [ *label* ] DECF *f*,*d*  
Operands:                     $0 \leq f \leq 127$   
                                  *d* ∈ [0,1]  
Operation:                    (*f*) - 1 → (destination)  
Status Affected:            Z  
Description:                Decrement register 'f'. If 'd' is '0', the result is stored in the W register. If 'd' is '1', the result is stored back in register 'f'.

---

**CLRW**                      **Clear W**

---

Syntax:                      [ *label* ] CLRW  
Operands:                    None  
Operation:                    00h → (*W*)  
                                  1 → Z  
Status Affected:            Z  
Description:                W register is cleared. Zero bit (Z) is set.

## **DECFSZ      Decrement f, Skip if 0**

**Syntax:**            *[label]* DECFSZ f,d

**Operands:**         $0 \leq f \leq 127$   
 $d \in [0,1]$

**Operation:**         $(f) - 1 \rightarrow (\text{destination});$   
skip if result = 0

**Status Affected:**    None

**Description:**      The contents of register 'f' are decremented. If 'd' is '0', the result is placed in the W register. If 'd' is '1', the result is placed back in register 'f'. If the result is '1', the next instruction is executed. If the result is '0', then a NOP is executed instead, making it a 2-cycle instruction.

## **INCFSZ      Increment f, Skip if 0**

**Syntax:**            *[label]* INCFSZ f,d

**Operands:**         $0 \leq f \leq 127$   
 $d \in [0,1]$

**Operation:**         $(f) + 1 \rightarrow (\text{destination});$   
skip if result = 0

**Status Affected:**    None

**Description:**      The contents of register 'f' are incremented. If 'd' is '0', the result is placed in the W register. If 'd' is '1', the result is placed back in register 'f'. If the result is '1', the next instruction is executed. If the result is '0', a NOP is executed instead, making it a 2-cycle instruction.

## **GOTO        Unconditional Branch**

**Syntax:**            *[label]* GOTO k

**Operands:**         $0 \leq k \leq 2047$

**Operation:**         $k \rightarrow \text{PC}<10:0>$   
 $\text{PCLATH}<6:3> \rightarrow \text{PC}<14:11>$

**Status Affected:**    None

**Description:**      GOTO is an unconditional branch. The 11-bit immediate value is loaded into PC bits <10:0>. The upper bits of PC are loaded from PCLATH<4:3>. GOTO is a 2-cycle instruction.

## **IORLW      Inclusive OR literal with W**

**Syntax:**            *[label]* IORLW k

**Operands:**         $0 \leq k \leq 255$

**Operation:**         $(W) .\text{OR. } k \rightarrow (W)$

**Status Affected:**    Z

**Description:**      The contents of the W register are OR'ed with the 8-bit literal 'k'. The result is placed in the W register.

## **INCF        Increment f**

**Syntax:**            *[label]* INCF f,d

**Operands:**         $0 \leq f \leq 127$   
 $d \in [0,1]$

**Operation:**         $(f) + 1 \rightarrow (\text{destination})$

**Status Affected:**    Z

**Description:**      The contents of register 'f' are incremented. If 'd' is '0', the result is placed in the W register. If 'd' is '1', the result is placed back in register 'f'.

## **IORWF      Inclusive OR W with f**

**Syntax:**            *[label]* IORWF f,d

**Operands:**         $0 \leq f \leq 127$   
 $d \in [0,1]$

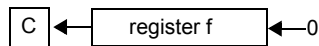
**Operation:**         $(W) .\text{OR. } (f) \rightarrow (\text{destination})$

**Status Affected:**    Z

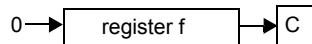
**Description:**      Inclusive OR the W register with register 'f'. If 'd' is '0', the result is placed in the W register. If 'd' is '1', the result is placed back in register 'f'.

# PIC16(L)F1764/5/8/9

<b>LSLF</b>	<b>Logical Left Shift</b>
Syntax:	[ <i>label</i> ] LSLF f {,d}
Operands:	$0 \leq f \leq 127$ $d \in [0,1]$
Operation:	$(f<7>) \rightarrow C$ $(f<6:0>) \rightarrow \text{dest}<7:1>$ $0 \rightarrow \text{dest}<0>$
Status Affected:	C, Z
Description:	The contents of register 'f' are shifted one bit to the left through the Carry flag. A '0' is shifted into the LSB. If 'd' is '0', the result is placed in W. If 'd' is '1', the result is stored back in register 'f'.



<b>LSRF</b>	<b>Logical Right Shift</b>
Syntax:	[ <i>label</i> ] LSRF f {,d}
Operands:	$0 \leq f \leq 127$ $d \in [0,1]$
Operation:	$0 \rightarrow \text{dest}<7>$ $(f<7:1>) \rightarrow \text{dest}<6:0>$ , $(f<0>) \rightarrow C$ ,
Status Affected:	C, Z
Description:	The contents of register 'f' are shifted one bit to the right through the Carry flag. A '0' is shifted into the MSb. If 'd' is '0', the result is placed in W. If 'd' is '1', the result is stored back in register 'f'.



<b>MOVF</b>	<b>Move f</b>
Syntax:	[ <i>label</i> ] MOVF f,d
Operands:	$0 \leq f \leq 127$ $d \in [0,1]$
Operation:	$(f) \rightarrow (\text{dest})$
Status Affected:	Z
Description:	The contents of register f are moved to a destination dependent upon the status of d. If d = 0, destination is W register. If d = 1, the destination is file register f itself. d = 1 is useful to test a file register since status flag Z is affected.

Words: 1  
Cycles: 1

Example: MOVF FSR, 0

After Instruction  
W = value in FSRn register  
Z = 1

## MOVIW Move INDFn to W

Syntax: `[label] MOVIW ++FSRn`  
`[label] MOVIW --FSRn`  
`[label] MOVIW FSRn++`  
`[label] MOVIW FSRn--`  
`[label] MOVIW k[FSRn]`

Operands:  $n \in [0,1]$   
 $mm \in [00,01,10,11]$   
 $-32 \leq k \leq 31$

Operation:  $INDFn \rightarrow W$   
 Effective address is determined by

- $FSRn + 1$  (preincrement)
- $FSRn - 1$  (predecrement)
- $FSRn + k$  (relative offset)

After the Move, the FSRn value will be either:

- $FSRn + 1$  (all increments)
- $FSRn - 1$  (all decrements)
- Unchanged

Status Affected: Z

Mode	Syntax	mm
Preincrement	<code>++FSRn</code>	00
Predecrement	<code>--FSRn</code>	01
Postincrement	<code>FSRn++</code>	10
Postdecrement	<code>FSRn--</code>	11

Description: This instruction is used to move data between W and one of the indirect registers (INDFn). Before/after this move, the pointer (FSRn) is updated by pre/post incrementing/decrementing it.

**Note:** The INDFn registers are not physical registers. Any instruction that accesses an INDFn register actually accesses the register at the address specified by the FSRn.

FSRn is limited to the range 0000h-FFFFh. Incrementing/decrementing it beyond these bounds will cause it to wrap around.

## MOVLB Move literal to BSR

Syntax: `[label] MOVLB k`

Operands:  $0 \leq k \leq 31$

Operation:  $k \rightarrow BSR$

Status Affected: None

Description: The 5-bit literal 'k' is loaded into the Bank Select Register (BSR).

## MOVLP Move literal to PCLATH

Syntax: `[label] MOVLP k`

Operands:  $0 \leq k \leq 127$

Operation:  $k \rightarrow PCLATH$

Status Affected: None

Description: The 7-bit literal 'k' is loaded into the PCLATH register.

## MOVLW Move literal to W

Syntax: `[label] MOVLW k`

Operands:  $0 \leq k \leq 255$

Operation:  $k \rightarrow (W)$

Status Affected: None

Description: The 8-bit literal 'k' is loaded into W register. The "don't cares" will assemble as '0's.

Words: 1

Cycles: 1

**Example:** `MOVLW 0x5A`  
 After Instruction  
 $W = 0x5A$

## MOVWF Move W to f

Syntax: `[label] MOVWF f`

Operands:  $0 \leq f \leq 127$

Operation:  $(W) \rightarrow (f)$

Status Affected: None

Description: Move data from W register to register 'f'.

Words: 1

Cycles: 1

**Example:** `MOVWF OPTION_REG`  
 Before Instruction  
 $OPTION\_REG = 0xFF$   
 $W = 0x4F$   
 After Instruction  
 $OPTION\_REG = 0x4F$   
 $W = 0x4F$

<b>MOVWI</b>	<b>Move W to INDFn</b>
Syntax:	[ <i>label</i> ] MOVWI ++FSRn [ <i>label</i> ] MOVWI --FSRn [ <i>label</i> ] MOVWI FSRn++ [ <i>label</i> ] MOVWI FSRn-- [ <i>label</i> ] MOVWI k[FSRn]
Operands:	n ∈ [0,1] mm ∈ [00,01, 10, 11] -32 ≤ k ≤ 31
Operation:	W → INDFn Effective address is determined by <ul style="list-style-type: none"> <li>• FSRn + 1 (preincrement)</li> <li>• FSRn – 1 (predecrement)</li> <li>• FSRn + k (relative offset)</li> </ul> After the Move, the FSRn value will be either: <ul style="list-style-type: none"> <li>• FSRn + 1 (all increments)</li> <li>• FSRn – 1 (all decrements)</li> </ul> Unchanged
Status Affected:	None

Mode	Syntax	mm
Preincrement	++FSRn	00
Predecrement	--FSRn	01
Postincrement	FSRn++	10
Postdecrement	FSRn--	11

**Description:** This instruction is used to move data between W and one of the indirect registers (INDFn). Before/after this move, the pointer (FSRn) is updated by pre/post incrementing/decrementing it.

**Note:** The INDFn registers are not physical registers. Any instruction that accesses an INDFn register actually accesses the register at the address specified by the FSRn.

FSRn is limited to the range 0000h-FFFFh. Incrementing/decrementing it beyond these bounds will cause it to wrap-around.

The increment/decrement operation on FSRn WILL NOT affect any Status bits.

<b>NOP</b>	<b>No Operation</b>
Syntax:	[ <i>label</i> ] NOP
Operands:	None
Operation:	No operation
Status Affected:	None
Description:	No operation.
Words:	1
Cycles:	1
<u>Example:</u>	NOP

## **OPTION** Load OPTION\_REG Register with W

Syntax:	[ <i>label</i> ] OPTION
Operands:	None
Operation:	(W) → OPTION_REG
Status Affected:	None
Description:	Move data from W register to OPTION_REG register.

Words: 1  
Cycles: 1

Example: OPTION  
Before Instruction  
OPTION\_REG = 0xFF  
W = 0x4F  
After Instruction  
OPTION\_REG = 0x4F  
W = 0x4F

<b>RESET</b>	<b>Software Reset</b>
Syntax:	[ <i>label</i> ] RESET
Operands:	None
Operation:	Execute a device Reset. Resets the RI flag of the PCON register.
Status Affected:	None
Description:	This instruction provides a way to execute a hardware Reset by software.

# PIC16(L)F1764/5/8/9

<b>RETFIE</b>	<b>Return from Interrupt</b>
Syntax:	[ <i>label</i> ] RETFIE k
Operands:	None
Operation:	TOS → PC, 1 → GIE
Status Affected:	None
Description:	Return from Interrupt. Stack is POPed and Top-of-Stack (TOS) is loaded in the PC. Interrupts are enabled by setting Global Interrupt Enable bit, GIE (INTCON<7>). This is a 2-cycle instruction.
Words:	1
Cycles:	2
<u>Example:</u>	<pre> RETFIE After Interrupt     PC = TOS     GIE = 1 </pre>

<b>RETURN</b>	<b>Return from Subroutine</b>
Syntax:	[ <i>label</i> ] RETURN
Operands:	None
Operation:	TOS → PC
Status Affected:	None
Description:	Return from subroutine. The stack is POPed and the top of the stack (TOS) is loaded into the Program Counter. This is a 2-cycle instruction.

<b>RETLW</b>	<b>Return with literal in W</b>
Syntax:	[ <i>label</i> ] RETLW k
Operands:	0 ≤ k ≤ 255
Operation:	k → (W); TOS → PC
Status Affected:	None
Description:	The W register is loaded with the 8-bit literal 'k'. The Program Counter is loaded from the top of the stack (the return address). This is a 2-cycle instruction.
Words:	1
Cycles:	2
<u>Example:</u>	<pre> CALL TABLE;W contains table     ;offset value     ;W now has table value     .     .     ADDWF PC ;W = offset     RETLW k1 ;Begin table     RETLW k2 ;     .     .     RETLW kn ; End of table </pre>
TABLE	
	<pre> Before Instruction     W = 0x07 After Instruction     W = value of k8 </pre>

<b>RLF</b>	<b>Rotate Left f through Carry</b>
Syntax:	[ <i>label</i> ] RLF f,d
Operands:	0 ≤ f ≤ 127 d ∈ [0,1]
Operation:	See description below
Status Affected:	C
Description:	The contents of register 'f' are rotated one bit to the left through the Carry flag. If 'd' is '0', the result is placed in the W register. If 'd' is '1', the result is stored back in register 'f'.
Words:	1
Cycles:	1
<u>Example:</u>	<pre> RLF    REG1,0 </pre>
	<p>Before Instruction</p> <pre> REG1 = 1110 0110 C    = 0 </pre> <p>After Instruction</p> <pre> REG1 = 1110 0110 W    = 1100 1100 C    = 1 </pre>

## RRF Rotate Right f through Carry

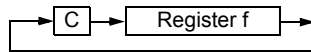
**Syntax:** `[label] RRF f,d`

**Operands:**  $0 \leq f \leq 127$   
 $d \in [0,1]$

**Operation:** See description below

**Status Affected:** C

**Description:** The contents of register 'f' are rotated one bit to the right through the Carry flag. If 'd' is '0', the result is placed in the W register. If 'd' is '1', the result is placed back in register 'f'.



## SUBLW Subtract W from literal

**Syntax:** `[label] SUBLW k`

**Operands:**  $0 \leq k \leq 255$

**Operation:**  $k - (W) \rightarrow (W)$

**Status Affected:** C, DC, Z

**Description:** The W register is subtracted (2's complement method) from the 8-bit literal 'k'. The result is placed in the W register.

C = 0	$W > k$
C = 1	$W \leq k$
DC = 0	$W\langle 3:0 \rangle > k\langle 3:0 \rangle$
DC = 1	$W\langle 3:0 \rangle \leq k\langle 3:0 \rangle$

## SLEEP Enter Sleep mode

**Syntax:** `[label] SLEEP`

**Operands:** None

**Operation:** 00h → WDT,  
 0 → WDT prescaler,  
 1 →  $\overline{TO}$ ,  
 0 →  $\overline{PD}$

**Status Affected:**  $\overline{TO}$ ,  $\overline{PD}$

**Description:** The Power-Down Status bit,  $\overline{PD}$ , is cleared. Time-out Status bit,  $\overline{TO}$ , is set. Watchdog Timer and its prescaler are cleared. The processor is put into Sleep mode with the oscillator stopped.

## SUBWF Subtract W from f

**Syntax:** `[label] SUBWF f,d`

**Operands:**  $0 \leq f \leq 127$   
 $d \in [0,1]$

**Operation:**  $(f) - (W) \rightarrow (\text{destination})$

**Status Affected:** C, DC, Z

**Description:** Subtract (2's complement method) W register from register 'f'. If 'd' is '0', the result is stored in the W register. If 'd' is '1', the result is stored back in register 'f'.

C = 0	$W > f$
C = 1	$W \leq f$
DC = 0	$W\langle 3:0 \rangle > f\langle 3:0 \rangle$
DC = 1	$W\langle 3:0 \rangle \leq f\langle 3:0 \rangle$

## SUBWFB Subtract W from f with Borrow

**Syntax:** `SUBWFB f {,d}`

**Operands:**  $0 \leq f \leq 127$   
 $d \in [0,1]$

**Operation:**  $(f) - (W) - (\overline{B}) \rightarrow \text{dest}$

**Status Affected:** C, DC, Z

**Description:** Subtract W and the Borrow flag (Carry) from register 'f' (2's complement method). If 'd' is '0', the result is stored in W. If 'd' is '1', the result is stored back in register 'f'.

# PIC16(L)F1764/5/8/9

---

## **SWAPF**      **Swap Nibbles in f**

---

Syntax:            [ *label* ] SWAPF f,d

Operands:         $0 \leq f \leq 127$   
                     $d \in [0,1]$

Operation:        ( $f<3:0>$ )  $\rightarrow$  (destination $<7:4>$ ),  
                    ( $f<7:4>$ )  $\rightarrow$  (destination $<3:0>$ )

Status Affected:    None

Description:      The upper and lower nibbles of register 'f' are exchanged. If 'd' is '0', the result is placed in the W register. If 'd' is '1', the result is placed in register 'f'.

## **XORLW**      **Exclusive OR literal with W**

---

Syntax:            [ *label* ] XORLW k

Operands:         $0 \leq k \leq 255$

Operation:        (W) .XOR. k  $\rightarrow$  (W)

Status Affected:    Z

Description:      The contents of the W register are XOR'ed with the 8-bit literal 'k'. The result is placed in the W register.

## **TRIS**        **Load TRIS Register with W**

---

Syntax:            [ *label* ] TRIS f

Operands:         $5 \leq f \leq 7$

Operation:        (W)  $\rightarrow$  TRIS register 'f'

Status Affected:    None

Description:      Move data from W register to TRIS register.  
                    When 'f' = 5, TRISA is loaded.  
                    When 'f' = 6, TRISB is loaded.  
                    When 'f' = 7, TRISC is loaded.

## **XORWF**      **Exclusive OR W with f**

---

Syntax:            [ *label* ] XORWF f,d

Operands:         $0 \leq f \leq 127$   
                     $d \in [0,1]$

Operation:        (W) .XOR. (f)  $\rightarrow$  (destination)

Status Affected:    Z

Description:      Exclusive OR the contents of the W register with register 'f'. If 'd' is '0', the result is stored in the W register. If 'd' is '1', the result is stored back in register 'f'.



## 36.0 ELECTRICAL SPECIFICATIONS

### 36.1 Absolute Maximum Ratings<sup>(†)</sup>

Ambient temperature under bias.....	-40°C to +125°C
Storage temperature .....	-65°C to +150°C
Voltage on pins with respect to V <sub>SS</sub>	
on V <sub>DD</sub> pin	
PIC16F1764/5/8/9 .....	-0.3V to +6.5V
PIC16LF1764/5/8/9 .....	-0.3V to +4.0V
on MCLR pin .....	-0.3V to +9.0V
on all other pins .....	-0.3V to (V <sub>DD</sub> + 0.3V)
Maximum current	
on V <sub>SS</sub> pin <sup>(1)</sup>	
-40°C ≤ T <sub>A</sub> ≤ +85°C .....	250 mA
+85°C ≤ T <sub>A</sub> ≤ +125°C .....	85 mA
on V <sub>DD</sub> pin <sup>(1)</sup>	
-40°C ≤ T <sub>A</sub> ≤ +85°C .....	250 mA
+85°C ≤ T <sub>A</sub> ≤ +125°C .....	85 mA
Sunk by any standard I/O pin .....	50 mA
Sourced by any standard I/O pin .....	50 mA
Sunk by any high-current I/O pin .....	100 mA
Sourced by any high-current I/O pin .....	100 mA
Sourced by any op amp output pin .....	100 mA
Clamp current, I <sub>K</sub> (V <sub>PIN</sub> < 0 or V <sub>PIN</sub> > V <sub>DD</sub> ) .....	±20 mA
Total power dissipation <sup>(2)</sup> .....	800 mW

**Note 1:** Maximum current rating requires even load distribution across I/O pins. Maximum current rating may be limited by the device package power dissipation characterizations, see [Table 36-6: Thermal Characteristics](#) to calculate device specifications.

**2:** Power dissipation is calculated as follows:  $P_{DIS} = V_{DD} \times \{I_{DD} - \sum I_{OH}\} + \sum \{(V_{DD} - V_{OH}) \times I_{OH}\} + \sum (V_{OL} \times I_{OL})$ .

† NOTICE: Stresses above those listed under “Absolute Maximum Ratings” may cause permanent damage to the device. This is a stress rating only and functional operation of the device at those or any other conditions above those indicated in the operation listings of this specification is not implied. Exposure above maximum rating conditions for extended periods may affect device reliability.

## 36.2 Standard Operating Conditions

The standard operating conditions for any device are defined as:

Operating Voltage:  $V_{DDMIN} \leq V_{DD} \leq V_{DDMAX}$

Operating Temperature:  $T_{A\_MIN} \leq T_A \leq T_{A\_MAX}$

### V<sub>DD</sub> – Operating Supply Voltage<sup>(1)</sup>

PIC16LF1764/5/8/9

V <sub>DDMIN</sub> (F <sub>OSC</sub> ≤ 16 MHz).....	+1.8V
V <sub>DDMIN</sub> (F <sub>OSC</sub> > 16 MHz).....	+2.5V
V <sub>DDMAX</sub> .....	+3.6V

PIC16F1764/5/8/9

V <sub>DDMIN</sub> (F <sub>OSC</sub> ≤ 16 MHz).....	+2.3V
V <sub>DDMIN</sub> (F <sub>OSC</sub> > 16 MHz).....	+2.5V
V <sub>DDMAX</sub> .....	+5.5V

### T<sub>A</sub> – Operating Ambient Temperature Range

Industrial Temperature

T <sub>A\_MIN</sub> .....	-40°C
T <sub>A\_MAX</sub> .....	+85°C

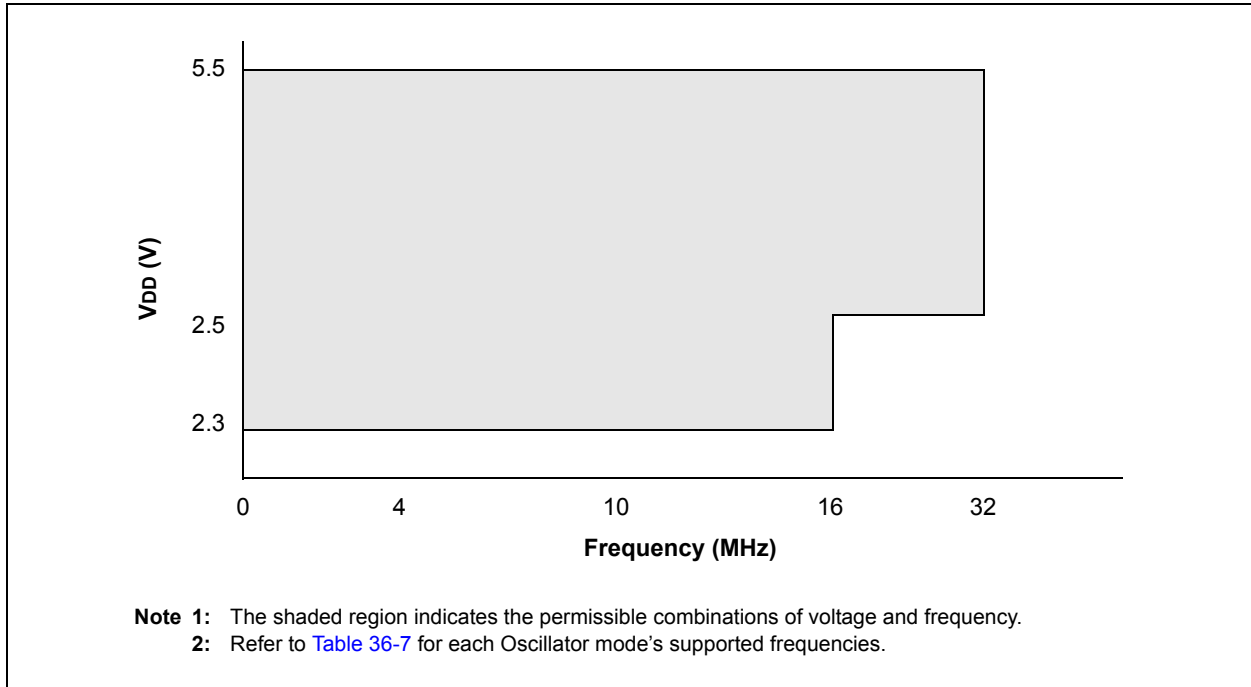
Extended Temperature

T <sub>A\_MIN</sub> .....	-40°C
T <sub>A\_MAX</sub> .....	+125°C

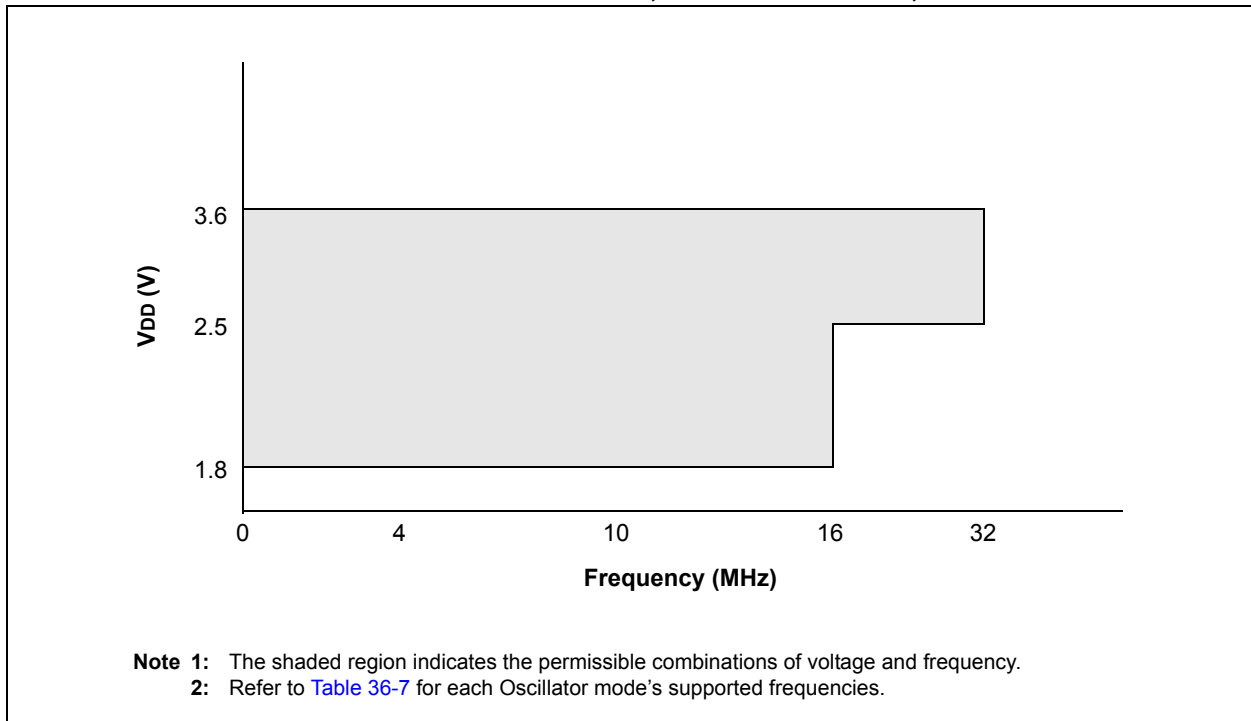
**Note 1:** See Parameter [D001](#), DS Characteristics: Supply Voltage.

# PIC16(L)F1764/5/8/9

**FIGURE 36-1: VOLTAGE FREQUENCY GRAPH,  $-40^{\circ}\text{C} \leq T_A \leq +125^{\circ}\text{C}$ , PIC16F1764/5/8/9 ONLY**



**FIGURE 36-2: VOLTAGE FREQUENCY GRAPH,  $-40^{\circ}\text{C} \leq T_A \leq +125^{\circ}\text{C}$ , PIC16LF1764/5/8/9 ONLY**



## 36.3 DC Characteristics

**TABLE 36-1: SUPPLY VOLTAGE**

PIC16LF1764/5/8/9		Standard Operating Conditions (unless otherwise stated)					
PIC16F1764/5/8/9							
Param. No.	Sym.	Characteristic	Min.	Typ†	Max.	Units	Conditions
D001	VDD	<b>Supply Voltage</b>					
			VDDMIN	—	VDDMAX	V	FOSC ≤ 16 MHz
			1.8	—	3.6	V	FOSC ≤ 32 MHz ( <b>Note 2</b> )
			2.5	—	3.6	V	
D001		PIC16F1764/5/8/9	2.3	—	5.5	V	FOSC ≤ 16 MHz:
			2.5	—	5.5	V	FOSC ≤ 32 MHz ( <b>Note 2</b> )
D002*	VDR	<b>RAM Data Retention Voltage<sup>(1)</sup></b>					
			1.5	—	—	V	Device in Sleep mode
D002*			1.7	—	—	V	Device in Sleep mode
D002A*	VPOR	<b>Power-on Reset Release Voltage<sup>(3)</sup></b>					
			—	1.6	—	V	
D002A*			—	1.6	—	V	
D002B*	VPORR*	<b>Power-on Reset Rearm Voltage<sup>(3)</sup></b>					
			—	0.8	—	V	
D002B*			—	1.5	—	V	
D003	VFVR	<b>Fixed Voltage Reference Voltage<sup>(4)</sup></b>					
			-4	—	+4	%	1x gain, 1.024, VDD ≥ 2.5V, -40°C to +85°C
			-4	—	+4	%	2x gain, 2.048, VDD ≥ 2.5V, -40°C to +85°C
			-5	—	+5	%	4x gain, 4.096, VDD ≥ 4.5V, -40°C to +85°C
D004*	SVDD	<b>VDD Rise Rate<sup>(2)</sup></b>	0.05	—	—	V/ms	Ensures that the Power-on Reset signal is released properly

\* These parameters are characterized but not tested.

† Data in "Typ" column is at 3.0V, +25°C unless otherwise stated. These parameters are for design guidance only and are not tested.

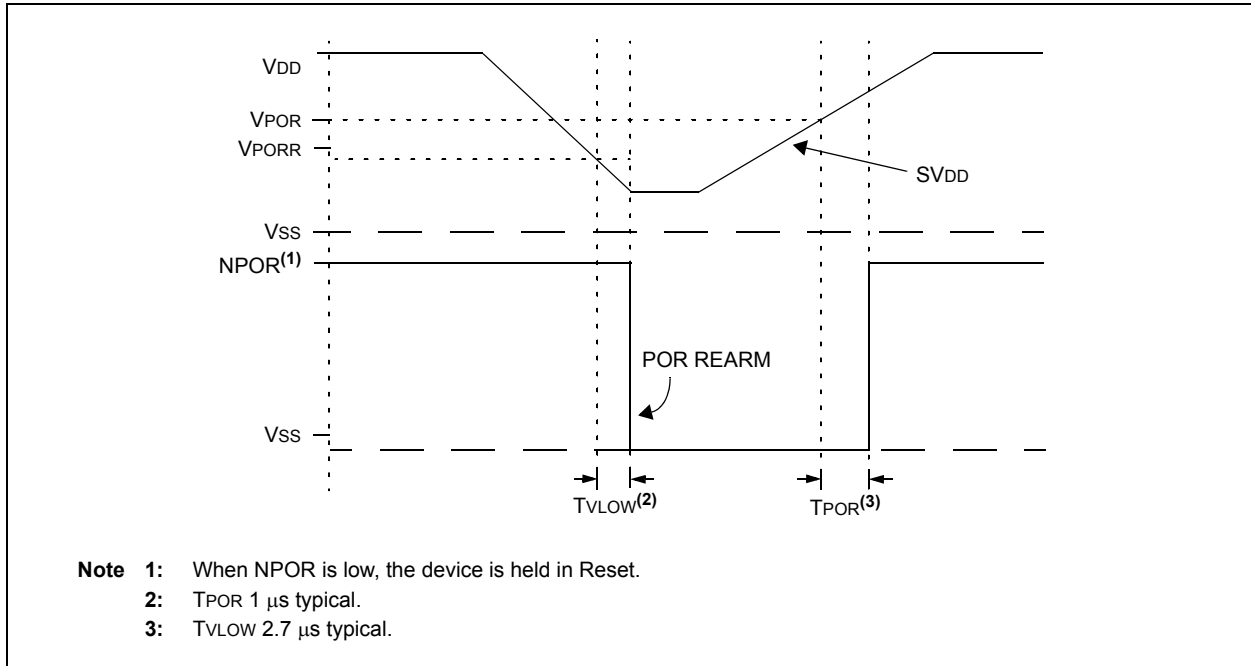
**Note 1:** This is the limit to which VDD can be lowered in Sleep mode without losing RAM data.

**Note 2:** PLL required for 32 MHz operation.

**Note 3:** See [Figure 36-3: POR and POR Rearm with Slow Rising VDD](#).

**Note 4:** Industrial temperature range only.

**FIGURE 36-3: POR AND POR REARM WITH SLOW RISING V<sub>DD</sub>**



**TABLE 36-2: SUPPLY CURRENT (IDD)<sup>(1,2)</sup>**

PIC16LF1764/5/8/9		Standard Operating Conditions (unless otherwise stated)					
PIC16F1764/5/8/9							
Param No.	Device Characteristics	Min.	Typ†	Max.	Units	Conditions	
						VDD	Note
D009	LDO Regulator	—	75	—	μA	—	High-Power mode, normal operation
		—	15	—	μA	—	Sleep, VREGCON<1> = 0
		—	0.3	—	μA	—	Sleep, VREGCON<1> = 1
D010		—	8	18	μA	1.8	Fosc = 32 kHz, LP Oscillator mode, -40°C ≤ TA ≤ +85°C
		—	11	20	μA	3.0	
D010		—	21	44	μA	2.3	Fosc = 32 kHz, LP Oscillator mode ( <b>Note 4</b> ), -40°C ≤ TA ≤ +85°C
		—	25	50	μA	3.0	
		—	26	54	μA	5.0	
D012		—	210	370	μA	1.8	Fosc = 4 MHz, XT Oscillator mode
		—	350	620	μA	3.0	
D012		—	290	400	μA	2.3	Fosc = 4 MHz, XT Oscillator mode
		—	400	650	μA	3.0	
		—	530	820	μA	5.0	
D014		—	180	270	μA	1.8	Fosc = 4 MHz, External Clock (ECM), Medium Power mode
		—	310	420	μA	3.0	
D014		—	230	360	μA	2.3	Fosc = 4 MHz, External Clock (ECM), Medium Power mode
		—	320	450	μA	3.0	
		—	460	650	μA	5.0	
D015		—	2.4	3	mA	3.0	Fosc = 32 MHz, External Clock (ECH), High-Power mode
		—	3.1	3.8	mA	3.6	
D015		—	2.5	3.1	mA	3.0	Fosc = 32 MHz, External Clock (ECH), High-Power mode
		—	2.7	3.5	mA	5.0	

† Data in “Typ” column is at 3.0V, +25°C unless otherwise stated. These parameters are for design guidance only and are not tested.

- Note 1:** The test conditions for all IDD measurements in active operation mode are: OSC1 = external square wave, from rail-to-rail; all I/O pins tri-stated, pulled to VDD; MCLR = VDD; WDT disabled.
- 2:** The supply current is mainly a function of the operating voltage and frequency. Other factors, such as I/O pin loading and switching rate, oscillator type, internal code execution pattern and temperature, also have an impact on the current consumption.
- 3:** For EXTRC oscillator configurations, current through REXT is not included. The current through the resistor can be extended by the formula:  $I_R = V_{DD}/2R_{EXT}$  (mA) with REXT in kΩ.
- 4:** FVR and BOR are disabled.
- 5:** 8 MHz crystal/oscillator with 4x PLL enabled.

# PIC16(L)F1764/5/8/9

**TABLE 36-2: SUPPLY CURRENT (IDD)<sup>(1,2)</sup> (CONTINUED)**

PIC16LF1764/5/8/9		Standard Operating Conditions					(unless otherwise stated)	
PIC16F1764/5/8/9								
Param No.	Device Characteristics	Min.	Typ†	Max.	Units	Conditions		
						VDD	Note	
D017		—	115	175	μA	1.8	Fosc = 500 kHz, MFINTOSC mode	
		—	145	210	μA	3.0		
D017		—	160	230	μA	2.3	Fosc = 500 kHz, MFINTOSC mode	
		—	180	260	μA	3.0		
		—	230	320	μA	5.0		
D019		—	0.9	1.3	mA	1.8	Fosc = 16 MHz, HFINTOSC mode	
		—	1.5	1.9	mA	3.0		
D019		—	1.2	1.8	mA	2.3	Fosc = 16 MHz, HFINTOSC mode	
		—	1.5	2	mA	3.0		
		—	1.7	2.1	mA	5.0		
D020		—	2.9	3.3	mA	3.0	Fosc = 32 MHz, HFINTOSC mode	
		—	3.5	4.1	mA	3.6		
D020		—	2.9	3.8	mA	3.0	Fosc = 32 MHz, HFINTOSC mode	
		—	3.0	3.9	mA	5.0		
D022		—	2.6	3.1	mA	3.0	Fosc = 32 MHz, HS Oscillator mode <b>(Note 5)</b>	
		—	3.4	3.9	mA	3.6		
D022		—	2.6	3.2	mA	3.0	Fosc = 32 MHz HS Oscillator mode <b>(Note 5)</b>	
		—	3.3	4.2	mA	5.0		

† Data in “Typ” column is at 3.0V, +25°C unless otherwise stated. These parameters are for design guidance only and are not tested.

- Note 1:** The test conditions for all IDD measurements in active operation mode are: OSC1 = external square wave, from rail-to-rail; all I/O pins tri-stated, pulled to VDD; MCLR = VDD; WDT disabled.
- 2:** The supply current is mainly a function of the operating voltage and frequency. Other factors, such as I/O pin loading and switching rate, oscillator type, internal code execution pattern and temperature, also have an impact on the current consumption.
- 3:** For EXTRC oscillator configurations, current through REXT is not included. The current through the resistor can be extended by the formula:  $I_R = V_{DD}/2R_{EXT}$  (mA) with REXT in kΩ.
- 4:** FVR and BOR are disabled.
- 5:** 8 MHz crystal/oscillator with 4x PLL enabled.

**TABLE 36-3: POWER-DOWN CURRENTS (IPD)<sup>(1,2)</sup>**

PIC16LF1764/5/8/9		Operating Conditions: (unless otherwise stated) Low-Power Sleep Mode						
PIC16F1764/5/8/9		Low-Power Sleep Mode, VREGPM = 1						
Param No.	Device Characteristics	Min.	Typ†	Max. +85°C	Max. +125°C	Units	Conditions	
							VDD	Note
D023	Base IPD	—	0.05	1.0	8.0	μA	1.8	WDT, BOR, FVR and SOSC disabled, all peripherals inactive
		—	0.08	2.0	9.0	μA	3.0	
D023	Base IPD	—	0.3	3	11	μA	2.3	WDT, BOR, FVR and SOSC disabled, all peripherals inactive, Low-Power Sleep mode
		—	0.4	4	12	μA	3.0	
		—	0.5	6	15	μA	5.0	
D023A	Base IPD	—	9.8	16	18	μA	2.3	WDT, BOR, FVR and SOSC disabled, all peripherals inactive, Normal Power Sleep mode, VREGPM = 0
		—	10.3	18	20	μA	3.0	
		—	11.5	21	26	μA	5.0	
D024		—	0.5	6	14	μA	1.8	WDT current
		—	0.8	7	17	μA	3.0	
D024		—	0.8	6	15	μA	2.3	WDT current
		—	0.9	7	20	μA	3.0	
		—	1.0	8	22	μA	5.0	
D025		—	15	28	30	μA	1.8	FVR current
		—	24	35	38	μA	3.0	
D025		—	18	33	35	μA	2.3	FVR current
		—	24	35	37	μA	3.0	
		—	26	37	39	μA	5.0	
D026		—	7.5	25	28	μA	3.0	BOR current
D026		—	10	25	28	μA	3.0	BOR current
		—	12	28	31	μA	5.0	
D027		—	0.5	4	10	μA	3.0	LPBOR current
D027		—	0.8	6	14	μA	3.0	LPBOR current
		—	1	8	17	μA	5.0	
D028		—	0.5	5	9	μA	1.8	SOSC current
		—	0.8	8.5	12	μA	3.0	
D028		—	1.1	6	10	μA	2.3	SOSC current
		—	1.3	8.5	20	μA	3.0	
		—	1.4	10	25	μA	5.0	
D029		—	0.05	2	9	μA	1.8	ADC current, no conversion in progress ( <b>Note 3</b> )
		—	0.08	3	10	μA	3.0	
D029		—	0.3	4	12	μA	2.3	ADC current, no conversion in progress ( <b>Note 3</b> )
		—	0.4	5	13	μA	3.0	
		—	0.5	7	16	μA	5.0	

\* These parameters are characterized but not tested.

† Data in "Typ" column is at 3.0V, +25°C unless otherwise stated. These parameters are for design guidance only and are not tested.

- Note 1:** The peripheral current is the sum of the base IPD and the additional current consumed when this peripheral is enabled. The peripheral Δ current can be determined by subtracting the base IDD or IPD current from this limit. Max values should be used when calculating total current consumption.
- 2:** The power-down current in Sleep mode does not depend on the oscillator type. Power-down current is measured with the part in Sleep mode, with all I/O pins in high-impedance state and tied to Vss.
- 3:** ADC clock source is FRC.



# PIC16(L)F1764/5/8/9

**TABLE 36-3: POWER-DOWN CURRENTS (IPD)<sup>(1,2)</sup> (CONTINUED)**

PIC16LF1764/5/8/9		Operating Conditions: (unless otherwise stated) Low-Power Sleep Mode						
PIC16F1764/5/8/9		Low-Power Sleep Mode, VREGPM = 1						
Param No.	Device Characteristics	Min.	Typ†	Max. +85°C	Max. +125°C	Units	Conditions	
							VDD	Note
D030		—	250	—	—	μA	1.8	ADC current, conversion in progress ( <b>Note 3</b> )
		—	250	—	—	μA	3.0	
D030		—	280	—	—	μA	2.3	ADC current, conversion in progress ( <b>Note 3</b> )
		—	280	—	—	μA	3.0	
		—	380	—	—	μA	5.0	
D031		—	250	650	—	μA	3.0	Op Amp (high power)
D031		—	250	650	—	μA	3.0	Op Amp (high power)
		—	350	850	—	μA	5.0	
D032		—	250	600	—	μA	1.8	Comparator
		—	300	650	—	μA	3.0	
D032		—	280	600	—	μA	2.3	Comparator, VREGPM = 0
		—	300	650	—	μA	3.0	
		—	310	650	—	μA	5.0	

\* These parameters are characterized but not tested.

† Data in “Typ” column is at 3.0V, +25°C unless otherwise stated. These parameters are for design guidance only and are not tested.

- Note 1:** The peripheral current is the sum of the base IPD and the additional current consumed when this peripheral is enabled. The peripheral Δ current can be determined by subtracting the base IDD or IPD current from this limit. Max values should be used when calculating total current consumption.
- 2:** The power-down current in Sleep mode does not depend on the oscillator type. Power-down current is measured with the part in Sleep mode, with all I/O pins in high-impedance state and tied to Vss.
- 3:** ADC clock source is FRC.

# PIC16(L)F1764/5/8/9

**TABLE 36-4: I/O PORTS**

Standard Operating Conditions (unless otherwise stated)								
Param No.	Sym.	Characteristic	Min.	Typ†	Max.	Units	Conditions	
D034 D034A D035 D036 D036A	V <sub>IL</sub>	<b>Input Low Voltage</b>						
		I/O Ports:						
		with TTL Buffer	—	—	0.8	V	4.5V ≤ V <sub>DD</sub> ≤ 5.5V	
		with Schmitt Trigger Buffer	—	—	0.15 V <sub>DD</sub>	V	1.8V ≤ V <sub>DD</sub> ≤ 4.5V	
		with I <sup>2</sup> C Levels	—	—	0.2 V <sub>DD</sub>	V	2.0V ≤ V <sub>DD</sub> ≤ 5.5V	
		with SMBus Levels	—	—	0.3 V <sub>DD</sub>	V		
D036		MCLR, OSC1 (EXTRC mode)	—	—	0.2 V <sub>DD</sub>	V	(Note 1)	
D036A		OSC1 (HS mode)	—	—	0.3 V <sub>DD</sub>	V		
D040 D040A D041 D042 D043A D043B	V <sub>IH</sub>	<b>Input High Voltage</b>						
		I/O Ports:						
		with TTL Buffer	2.0	—	—	V	4.5V ≤ V <sub>DD</sub> ≤ 5.5V	
		with Schmitt Trigger Buffer	0.25 V <sub>DD</sub> + 0.8	—	—	V	1.8V ≤ V <sub>DD</sub> ≤ 4.5V	
		with I <sup>2</sup> C Levels	0.8 V <sub>DD</sub>	—	—	V	2.0V ≤ V <sub>DD</sub> ≤ 5.5V	
		with SMBus Levels	0.7 V <sub>DD</sub>	—	—	V		
		with SMBus Levels	2.1	—	—	V	2.7V ≤ V <sub>DD</sub> ≤ 5.5V	
		D042		MCLR	0.8 V <sub>DD</sub>	—	—	V
D043A		OSC1 (HS mode)	0.7 V <sub>DD</sub>	—	—	V		
D043B		OSC1 (EXTRC oscillator)	0.9 V <sub>DD</sub>	—	—	V	V <sub>DD</sub> > 2.0V (Note 1)	
D060 D061	I <sub>IL</sub>	<b>Input Leakage Current<sup>(2)</sup></b>						
		I/O Ports	—	± 5	± 125	nA	V <sub>SS</sub> ≤ V <sub>PIN</sub> ≤ V <sub>DD</sub> , Pin at high-impedance, +85°C	
			—	± 5	± 1000	nA	V <sub>SS</sub> ≤ V <sub>PIN</sub> ≤ V <sub>DD</sub> , Pin at high-impedance, +125°C	
D061		MCLR <sup>(3)</sup>	—	± 50	± 200	nA	V <sub>SS</sub> ≤ V <sub>PIN</sub> ≤ V <sub>DD</sub> , Pin at high-impedance, +85°C	
D070*	I <sub>PUR</sub>	<b>Weak Pull-up Current</b>						
			25	100	200	μA	V <sub>DD</sub> = 3.3V, V <sub>PIN</sub> = V <sub>SS</sub>	
			25	140	300	μA	V <sub>DD</sub> = 5.0V, V <sub>PIN</sub> = V <sub>SS</sub>	
D080 D080A	V <sub>OL</sub>	<b>Output Low Voltage<sup>(4)</sup></b>						
		Standard I/O ports	—	—	0.6	V	I <sub>OL</sub> = 8mA, V <sub>DD</sub> = 5V I <sub>OL</sub> = 6mA, V <sub>DD</sub> = 3.3V I <sub>OL</sub> = 1.8mA, V <sub>DD</sub> = 1.8V	
		High Drive I/O ports	—	—	0.6	V	I <sub>OH</sub> = 10mA, V <sub>DD</sub> = 2.3V, H <sub>IDC</sub> x = 1	
			—	0.6	—	V	I <sub>OH</sub> = 32mA, V <sub>DD</sub> = 3.0V, H <sub>IDC</sub> x = 1	
—	0.6		—	V	I <sub>OH</sub> = 51mA, V <sub>DD</sub> = 5.0V, H <sub>IDC</sub> x = 1			

\* These parameters are characterized but not tested.

† Data in "Typ" column is at 3.0V, +25°C unless otherwise stated. These parameters are for design guidance only and are not tested.

**Note 1:** In EXTRC oscillator configuration, the OSC1/CLKIN pin is a Schmitt Trigger input. It is not recommended to use an external clock in EXTRC mode.

**2:** Negative current is defined as current sourced by the pin.

**3:** The leakage current on the MCLR pin is strongly dependent on the applied voltage level. The specified levels represent normal operating conditions. Higher leakage current may be measured at different input voltages.

**4:** Including OSC2 in CLKOUT mode.

# PIC16(L)F1764/5/8/9

**TABLE 36-4: I/O PORTS (CONTINUED)**

Standard Operating Conditions (unless otherwise stated)							
Param No.	Sym.	Characteristic	Min.	Typ†	Max.	Units	Conditions
D090	VOH	<b>Output High Voltage<sup>(4)</sup></b>					
		Standard I/O Ports	$V_{DD} - 0.7$	—	—	V	IOH = 3.5mA, VDD = 5V IOH = 3mA, VDD = 3.3V IOH = 1mA, VDD = 1.8V
D090A		High Drive I/O Ports	$V_{DD} - 0.7$	—	—	V	IOH = 10mA, VDD = 2.3V, HICx = 1
			—	$V_{DD} - 0.7$	—	V	IOH = 37mA, VDD = 3.0V, HICx = 1
			—	$V_{DD} - 0.7$	—	V	IOH = 54mA, VDD = 5.0V, HICx = 1
D101*	COS2	<b>Capacitive Loading Specs on Output Pins</b>					
		OSC2 Pin	—	—	15	pF	In XT, HS and LP modes when external clock is used to drive OSC1
D101A*	Cio	All I/O Pins	—	—	50	pF	

\* These parameters are characterized but not tested.

† Data in "Typ" column is at 3.0V, +25°C unless otherwise stated. These parameters are for design guidance only and are not tested.

**Note 1:** In EXTRC oscillator configuration, the OSC1/CLKIN pin is a Schmitt Trigger input. It is not recommended to use an external clock in EXTRC mode.

**2:** Negative current is defined as current sourced by the pin.

**3:** The leakage current on the MCLR pin is strongly dependent on the applied voltage level. The specified levels represent normal operating conditions. Higher leakage current may be measured at different input voltages.

**4:** Including OSC2 in CLKOUT mode.

# PIC16(L)F1764/5/8/9

**TABLE 36-5: MEMORY PROGRAMMING SPECIFICATIONS**

Standard Operating Conditions (unless otherwise stated)							
Param No.	Sym.	Characteristic	Min.	Typ†	Max.	Units	Conditions
<b>Program Memory Programming Specifications</b>							
D110	VIHH	Voltage on $\overline{\text{MCLR}}$ /VPP Pin	8.0	—	9.0	V	<b>(Note 2)</b>
D111	IDDP	Supply Current during Programming	—	—	10	mA	
D112	VBE	VDD for Bulk Erase	2.7	—	VDDMAX	V	
D113	VPEW	VDD for Write or Row Erase	VDDMIN	—	VDDMAX	V	
D114	IPPPGM	Current on $\overline{\text{MCLR}}$ /VPP during Erase/Write	—	1.0	—	mA	
D115	IDDPGM	Current on VDD during Erase/Write	—	5.0	—	mA	
<b>Program Flash Memory</b>							
D121	EP	Cell Endurance	10K	—	—	E/W	<b>-40°C ≤ Ta ≤ +85°C (Note 1)</b>
D122	VPRW	VDD for Read/Write	VDDMIN	—	VDDMAX	V	
D123	TIW	Self-Timed Write Cycle Time	—	2	2.5	ms	Provided no other specifications are violated
D124	TRETD	Characteristic Retention	—	40	—	Year	
D125	EHEFC	High-Endurance Flash Cell	100K	—	—	E/W	<b>-0°C ≤ Ta ≤ +60°C, Lower byte last 128 addresses</b>

† Data in “Typ” column is at 3.0V, +25°C unless otherwise stated. These parameters are for design guidance only and are not tested.

**Note 1:** Self-write and block erase.

**2:** Required only if single-supply programming is disabled.

**TABLE 36-6: THERMAL CHARACTERISTICS**
**Standard Operating Conditions** (unless otherwise stated)

Param No.	Sym.	Characteristic	Typ.	Units	Conditions
TH01	θJA	Thermal Resistance Junction to Ambient	70.0	°C/W	14-pin PDIP package
			95.3	°C/W	14-pin SOIC package
			100.0	°C/W	14-pin TSSOP package
			51.5	°C/W	16-pin QFN 4x4 mm package
			62.2	°C/W	20-pin PDIP package
			87.3	°C/W	20-pin SSOP
			77.7	°C/W	20-pin SOIC package
			43.0	°C/W	20-pin QFN 4x4 mm package
TH02	θJC	Thermal Resistance Junction to Case	32.75	°C/W	14-pin PDIP package
			31.0	°C/W	14-pin SOIC package
			24.4	°C/W	14-pin TSSOP package
			5.4	°C/W	16-pin QFN 4x4 mm package
			27.5	°C/W	20-pin PDIP package
			31.1	°C/W	20-pin SSOP
			23.1	°C/W	20-pin SOIC package
			5.3	°C/W	20-pin QFN 4x4 mm package
TH03	TJMAX	Maximum Junction Temperature	150	°C	
TH04	PD	Power Dissipation	—	W	PD = PINTERNAL + PI/O
TH05	PINTERNAL	Internal Power Dissipation	—	W	PINTERNAL = IDD x VDD <sup>(1)</sup>
TH06	PI/O	I/O Power Dissipation	—	W	PI/O = Σ (IOL * VOL) + Σ (IOH * (VDD – VOH))
TH07	PDER	Derated Power	—	W	PDER = PDMAX (TJ – TA)/θJA <sup>(2)</sup>

**Note 1:** IDD is current to run the chip alone without driving any load on the output pins.

**Note 2:** TA = Ambient Temperature, TJ = Junction Temperature.

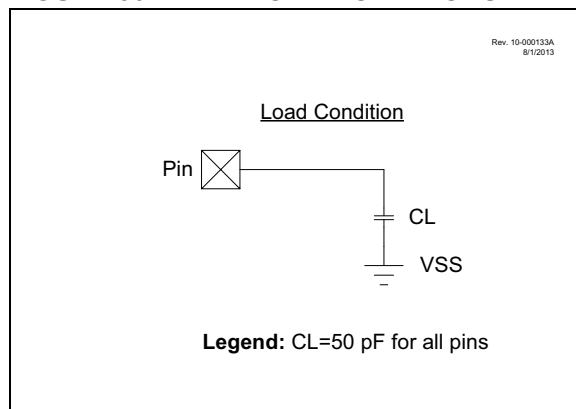
## 36.4 AC Characteristics

Timing Parameter Symbology has been created with one of the following formats:

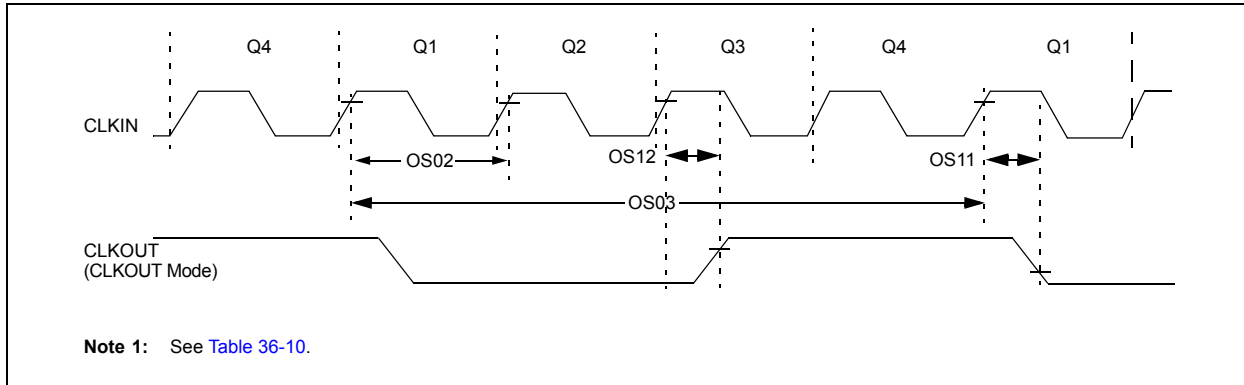
1. TppS2ppS
2. TppS

<b>T</b> F          Frequency	T          Time
Lowercase letters (pp) and their meanings:	
<b>pp</b> cc          CCP1 ck          CLKOUT cs          CS di          SDI do          SDO dt          Data in io          I/O PORT mc          MCLR	osc          OSC1 rd $\overline{RD}$ rw $\overline{RD}$ or $\overline{WR}$ sc          SCK ss $\overline{SS}$ t0          T0CKI t1          T1CKI wr $\overline{WR}$
Uppercase letters and their meanings:	
<b>S</b> F          Fall H          High I          Invalid (High-impedance) L          Low	P          Period R          Rise V          Valid Z          High-impedance

**FIGURE 36-4: LOAD CONDITIONS**



**FIGURE 36-5: CLOCK TIMING**



**TABLE 36-7: CLOCK OSCILLATOR TIMING REQUIREMENTS**

Standard Operating Conditions (unless otherwise stated)

Param No.	Sym.	Characteristic	Min.	Typ†	Max.	Units	Conditions			
OS01	FOSC	External CLKIN Frequency <sup>(1)</sup>	DC	—	0.5	MHz	External Clock (ECL)			
			DC	—	4	MHz	External Clock (ECM)			
			DC	—	20	MHz	External Clock (ECH)			
		Oscillator Frequency <sup>(1)</sup>	—	32.768	—	kHz	LP Oscillator			
			0.1	—	4	MHz	XT Oscillator			
			1	—	4	MHz	HS Oscillator			
1	—		20	MHz	HS Oscillator, V <sub>DD</sub> > 2.7V					
DC	—	4	MHz	EXTRC, V <sub>DD</sub> > 2.0V						
OS02	TOSC	External CLKIN Period <sup>(1)</sup>	27	—	∞	μs	LP Oscillator			
			250	—	∞	ns	XT Oscillator			
			50	—	∞	ns	HS Oscillator			
			50	—	∞	ns	External Clock (EC)			
		Oscillator Period <sup>(1)</sup>	—	30.5	—	μs	LP Oscillator			
			250	—	10,000	ns	XT Oscillator			
OS03	T <sub>cy</sub>	Instruction Cycle Time <sup>(1)</sup>	125	T <sub>cy</sub>	DC	ns	T <sub>cy</sub> = 4/FOSC			
			OS04*	TosH, TosL	External CLKIN High, External CLKIN Low	2	—	—	μs	LP Oscillator
						100	—	—	ns	XT Oscillator
						20	—	—	ns	HS Oscillator
OS05*	TosR, TosF	External CLKIN Rise, External CLKIN Fall	0	—	∞	ns	LP Oscillator			
			0	—	∞	ns	XT Oscillator			
			0	—	∞	ns	HS Oscillator			

\* These parameters are characterized but not tested.

† Data in "Typ" column is at 3.0V, +25°C unless otherwise stated. These parameters are for design guidance only and are not tested.

**Note 1:** Instruction cycle period (T<sub>cy</sub>) equals four times the input oscillator time base period. All specified values are based on characterization data for that particular oscillator type under standard operating conditions with the device executing code. Exceeding these specified limits may result in an unstable oscillator operation and/or higher than expected current consumption. All devices are tested to operate at "min" values with an external clock applied to the OSC1 pin. When an external clock input is used, the "max" cycle time limit is "DC" (no clock) for all devices.

# PIC16(L)F1764/5/8/9

**TABLE 36-8: OSCILLATOR PARAMETERS**

Standard Operating Conditions (unless otherwise stated)								
Param No.	Sym.	Characteristic	Freq. Tolerance	Min.	Typ†	Max.	Units	Conditions
OS08	HFosc	Internal Calibrated HFINTOSC Frequency <sup>(1)</sup>	±2%	—	16.0	—	MHz	V <sub>DD</sub> = 3.0V, T <sub>A</sub> = 25°C <b>(Note 2)</b>
OS08A	MFosc	Internal Calibrated MFINTOSC Frequency <sup>(1)</sup>	±2%	—	500	—	kHz	V <sub>DD</sub> = 3.0V, T <sub>A</sub> = 25°C <b>(Note 3)</b>
OS09	LFosc	Internal LFINTOSC Frequency	—	—	31	—	kHz	-40°C ≤ T <sub>A</sub> ≤ +125°C
OS10*	TWARM	HFINTOSC	—	—	3.2	8	μs	
		Wake-up from Sleep Start-up Time	—	—	24	35	μs	
		MFINTOSC	—	—	0.5	—	ms	
		Wake-up from Sleep Start-up Time	—	—	—	—	—	

\* These parameters are characterized but not tested.

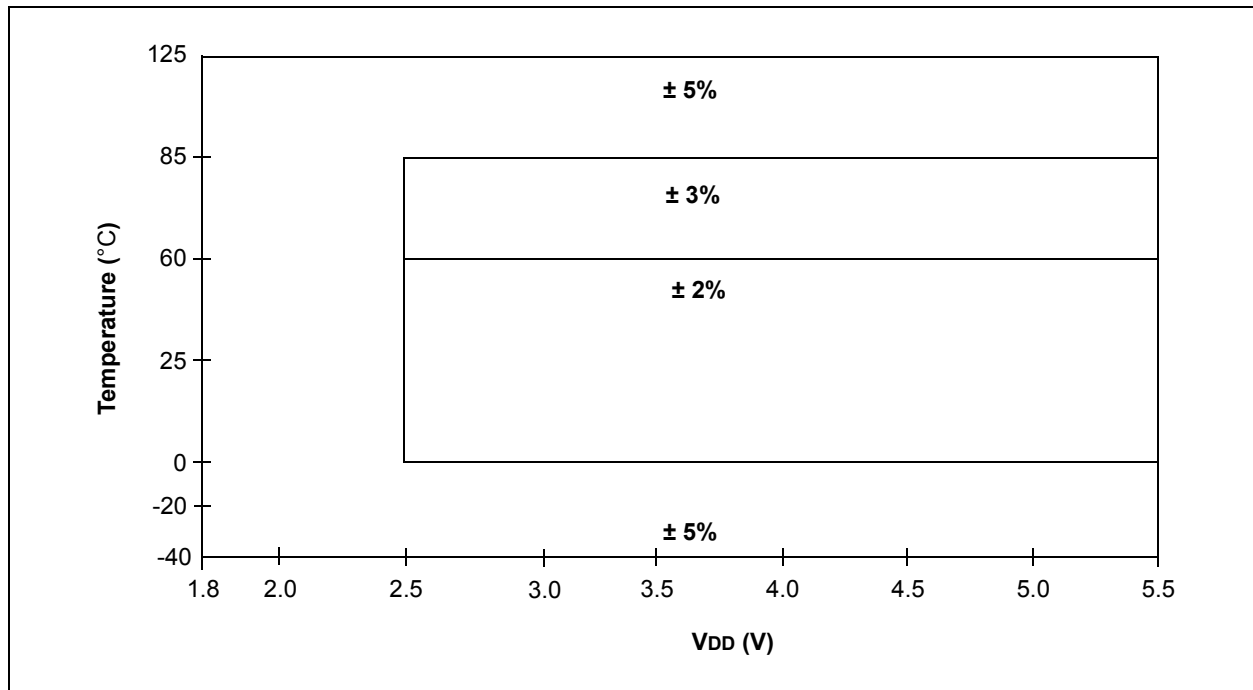
† Data in "Typ" column is at 3.0V, +25°C unless otherwise stated. These parameters are for design guidance only and are not tested.

**Note 1:** To ensure these oscillator frequency tolerances, V<sub>DD</sub> and V<sub>SS</sub> must be capacitively decoupled as close to the device as possible. 0.1 μF and 0.01 μF values in parallel are recommended.

**2:** See [Figure 37-74: Wake From Sleep, VREGPM = 0.](#) and [Figure 37-75: Wake From Sleep, VREGPM = 1.](#)

**3:** See [Figure 37-57: LFINTOSC Frequency, PIC16LF1764/5/8/9 Only.](#) and [Figure 37-58: LFINTOSC Frequency, PIC16F1764/5/8/9 Only.](#)

**FIGURE 36-6: HFINTOSC FREQUENCY ACCURACY OVER DEVICE V<sub>DD</sub> AND TEMPERATURE**





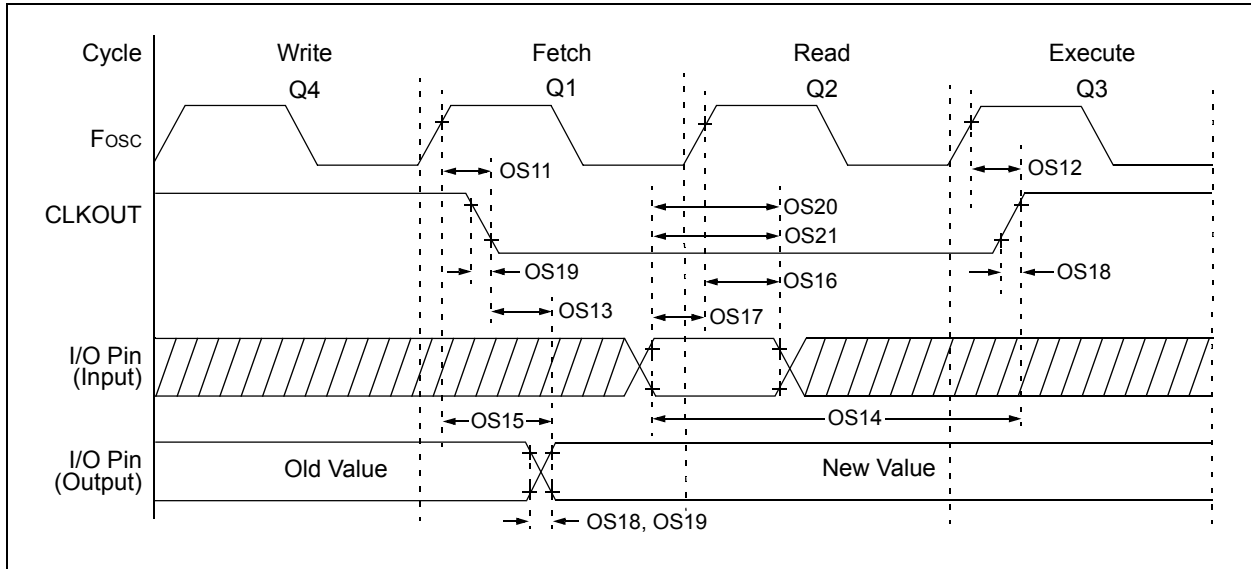
**TABLE 36-9: PLL CLOCK TIMING SPECIFICATIONS**

Standard Operating Conditions (unless otherwise stated)							
Param No.	Sym.	Characteristic	Min.	Typ†	Max.	Units	Conditions
F10	FOSC	Oscillator Frequency Range	4	—	8	MHz	
F11	FSYS	On-Chip VCO System Frequency	16	—	32	MHz	
F12	TRC	PLL Start-up Time (Lock Time)	—	—	2	ms	
F13*	$\Delta$ CLK	CLKOUT Stability (Jitter)	-0.25%	—	+0.25%	%	

\* These parameters are characterized but not tested.

† Data in “Typ” column is at 5V, +25°C unless otherwise stated. These parameters are for design guidance only and are not tested.

**FIGURE 36-7: CLKOUT AND I/O TIMING**



**TABLE 36-10: CLKOUT AND I/O TIMING PARAMETERS**

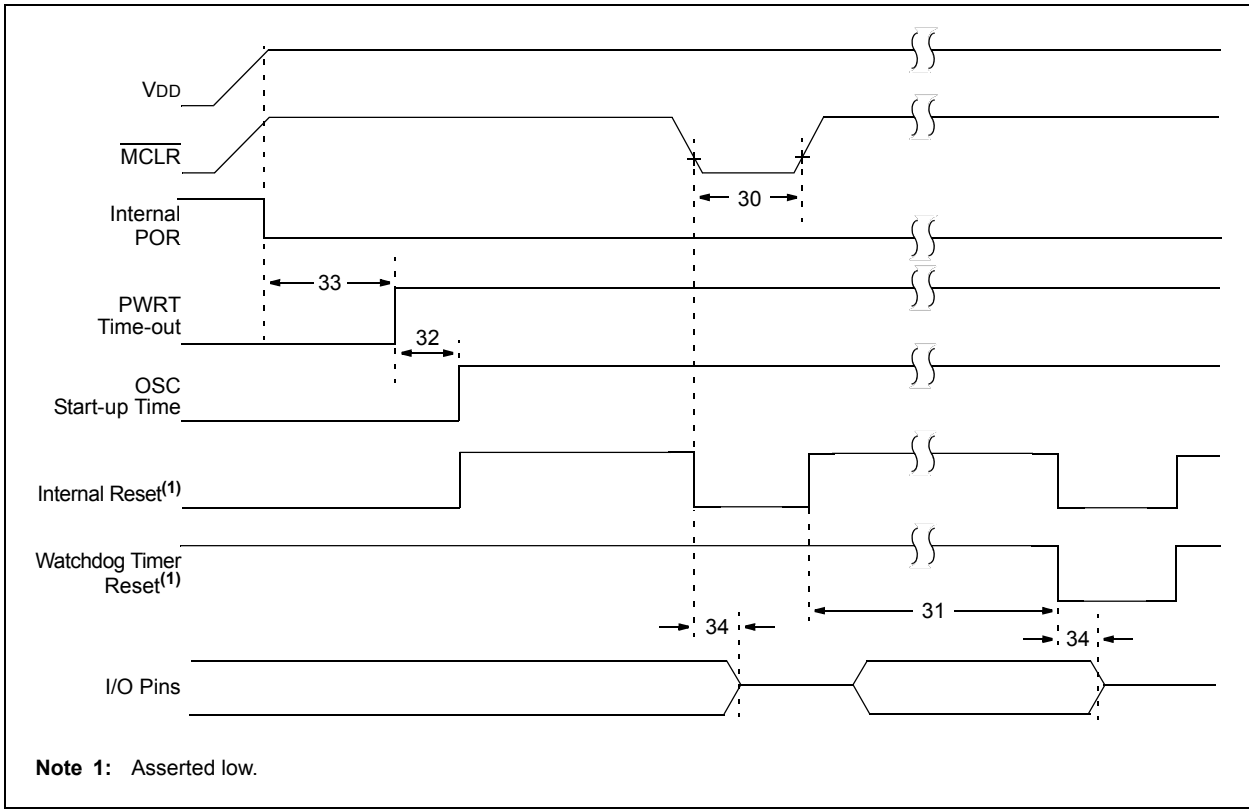
Standard Operating Conditions (unless otherwise stated)							
Param No.	Sym.	Characteristic	Min.	Typ†	Max.	Units	Conditions
OS11	TosH2ckL	Fosc↑ to CLKOUT↓ <sup>(1)</sup>	—	—	70	ns	3.3V ≤ VDD ≤ 5.0V
OS12	TosH2ckH	Fosc↑ to CLKOUT↑ <sup>(1)</sup>	—	—	72	ns	3.3V ≤ VDD ≤ 5.0V
OS13	TckL2ioV	CLKOUT↓ to Port Out Valid <sup>(1)</sup>	—	—	20	ns	
OS14	TioV2ckH	Port Input Valid before CLKOUT↑ <sup>(1)</sup>	Tosc + 200 ns	—	—	ns	
OS15	TosH2ioV	Fosc↑ (Q1 cycle) to Port Out Valid	—	50	70*	ns	3.3V ≤ VDD ≤ 5.0V
OS16	TosH2ioI	Fosc↑ (Q2 cycle) to Port Input Invalid (I/O in hold time)	50	—	—	ns	3.3V ≤ VDD ≤ 5.0V
OS17	TioV2osH	Port Input Valid to Fosc↑ (Q2 cycle) (I/O in setup time)	20	—	—	ns	
OS18*	TioR	Port Output Rise Time	—	40 15	72 32	ns	VDD = 1.8V, 3.3V ≤ VDD ≤ 5.0V
OS19*	TioF	Port Output Fall Time	—	28 15	55 30	ns	VDD = 1.8V, 3.3V ≤ VDD ≤ 5.0V
OS20*	Tinp	INT Pin Input High or Low Time	25	—	—	ns	
OS21*	Tioc	Interrupt-On-Change New Input Level Time	25	—	—	ns	

\* These parameters are characterized but not tested.

† Data in "Typ" column is at 3.0V, +25°C unless otherwise stated.

**Note 1:** Measurements are taken in EXTRC mode where CLKOUT output is 4 x Tosc.

**FIGURE 36-8: RESET, WATCHDOG TIMER, OSCILLATOR START-UP TIMER AND POWER-UP TIMER TIMING**



# PIC16(L)F1764/5/8/9

**TABLE 36-11: RESET, WATCHDOG TIMER, OSCILLATOR START-UP TIMER, POWER-UP TIMER AND BROWN-OUT RESET PARAMETERS**

Standard Operating Conditions (unless otherwise stated)							
Param No.	Sym.	Characteristic	Min.	Typ†	Max.	Units	Conditions
30	TMCL	MCLR Pulse Width (low)	2	—	—	μs	
31	TWDTLP	Low-Power Watchdog Timer Time-out Period	10	16	27	ms	VDD = 3.3V-5V, 1:512 prescaler used
32	TOST	Oscillator Start-up Timer Period <sup>(1)</sup>	—	1024	—	TOSC	
33*	TPWRT	Power-up Timer Period, $\overline{PWRT\overline{E}} = 0$	40	65	140	ms	
34*	TIOZ	I/O High-Impedance from MCLR Low or Watchdog Timer Reset	—	—	2.0	μs	
35	VBOR	Brown-out Reset Voltage <sup>(2)</sup>	2.55 2.30 1.80	2.70 2.45 1.90	2.85 2.60 2.10	V	BORV = 0 BORV = 1 (PIC16F1764/5/8/9) BORV = 1 (PIC16LF1764/5/8/9)
35A	VLPBOR	Low-Power Brown-out	1.8	2.1	2.5	V	LPBOR = 1
36*	VHYST	Brown-out Reset Hysteresis	0	25	75	mV	-40°C ≤ TA ≤ +85°C
37*	TBORDC	Brown-out Reset DC Response Time	1	3	35	μs	VDD ≤ VBOR

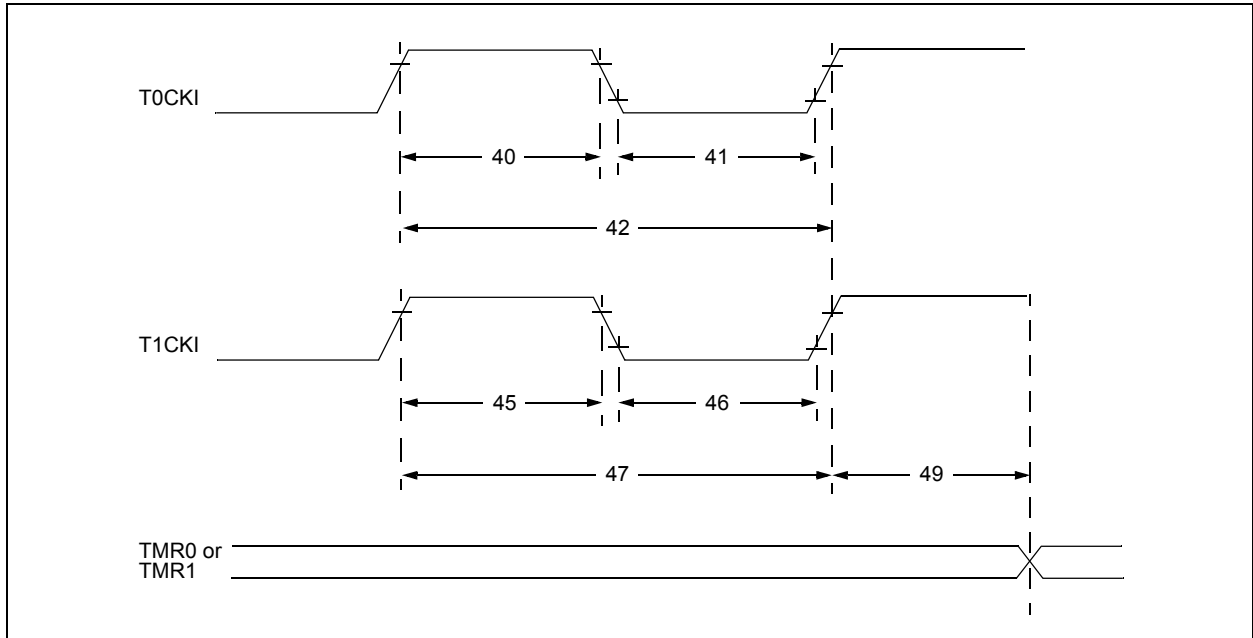
\* These parameters are characterized but not tested.

† Data in "Typ" column is at 3.0V, +25°C unless otherwise stated. These parameters are for design guidance only and are not tested.

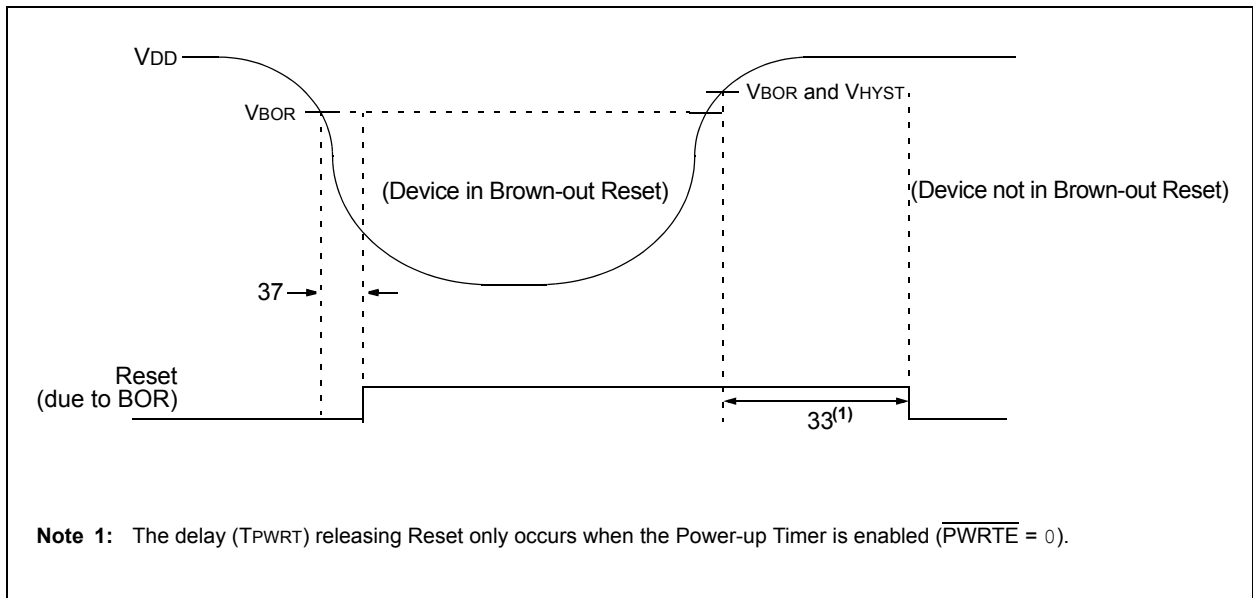
**Note 1:** By design, the Oscillator Start-up Timer (OST) counts the first 1024 cycles, independent of frequency.

**2:** To ensure these voltage tolerances, VDD and VSS must be capacitively decoupled as close to the device as possible. 0.1 μF and 0.01 μF values in parallel are recommended.

**FIGURE 36-9: TIMER0 AND TIMER1 EXTERNAL CLOCK TIMINGS**



**FIGURE 36-10: BROWN-OUT RESET TIMING AND CHARACTERISTICS**



# PIC16(L)F1764/5/8/9

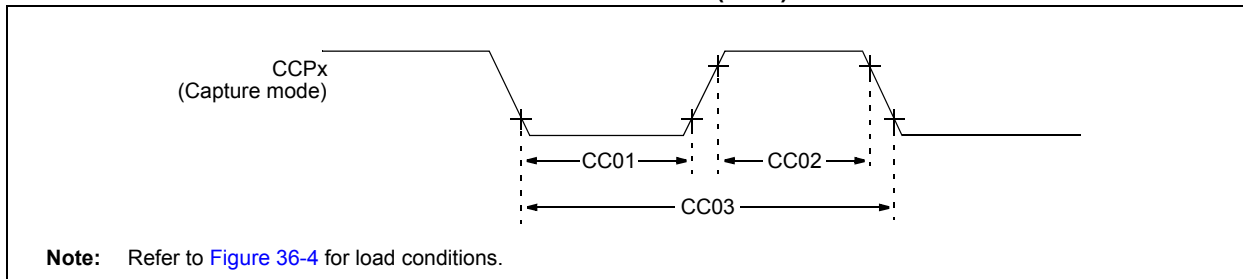
**TABLE 36-12: TIMER0 AND TIMER1 EXTERNAL CLOCK REQUIREMENTS**

Standard Operating Conditions (unless otherwise stated)									
Operating Temperature $-40^{\circ}\text{C} \leq T_A \leq +125^{\circ}\text{C}$									
Param No.	Sym.	Characteristic		Min.	Typ†	Max.	Units	Conditions	
40*	T <sub>T0H</sub>	T0CKI High Pulse Width	No Prescaler	$0.5 T_{CY} + 20$	—	—	ns		
			With Prescaler	10	—	—	ns		
41*	T <sub>T0L</sub>	T0CKI Low Pulse Width	No Prescaler	$0.5 T_{CY} + 20$	—	—	ns		
			With Prescaler	10	—	—	ns		
42*	T <sub>T0P</sub>	T0CKI Period		Greater of: $20$ or $\frac{T_{CY} + 40}{N}$	—	—	ns	N = prescale value	
45*	T <sub>T1H</sub>	T1CKI High Time	Synchronous, No Prescaler	$0.5 T_{CY} + 20$	—	—	ns		
			Synchronous, with Prescaler		15	—	—	ns	
			Asynchronous		30	—	—	ns	
46*	T <sub>T1L</sub>	T1CKI Low Time	Synchronous, No Prescaler	$0.5 T_{CY} + 20$	—	—	ns		
			Synchronous, with Prescaler		15	—	—	ns	
			Asynchronous		30	—	—	ns	
47*	T <sub>T1P</sub>	T1CKI Input Period	Synchronous	Greater of: $30$ or $\frac{T_{CY} + 40}{N}$	—	—	ns	N = prescale value	
			Asynchronous		60	—	—	ns	
48	F <sub>T1</sub>	Secondary Oscillator Input Frequency Range (oscillator enabled by setting bit, T1OSCEN)		32.4	32.768	33.1	kHz		
49*	TCKEZTMR1	Delay from External Clock Edge to Timer Increment		$2 T_{OSC}$	—	$7 T_{OSC}$	—	Timers in Sync mode	

\* These parameters are characterized but not tested.

† Data in "Typ" column is at 3.0V, +25°C unless otherwise stated. These parameters are for design guidance only and are not tested.

**FIGURE 36-11: CAPTURE/COMPARE/PWM TIMINGS (CCP)**



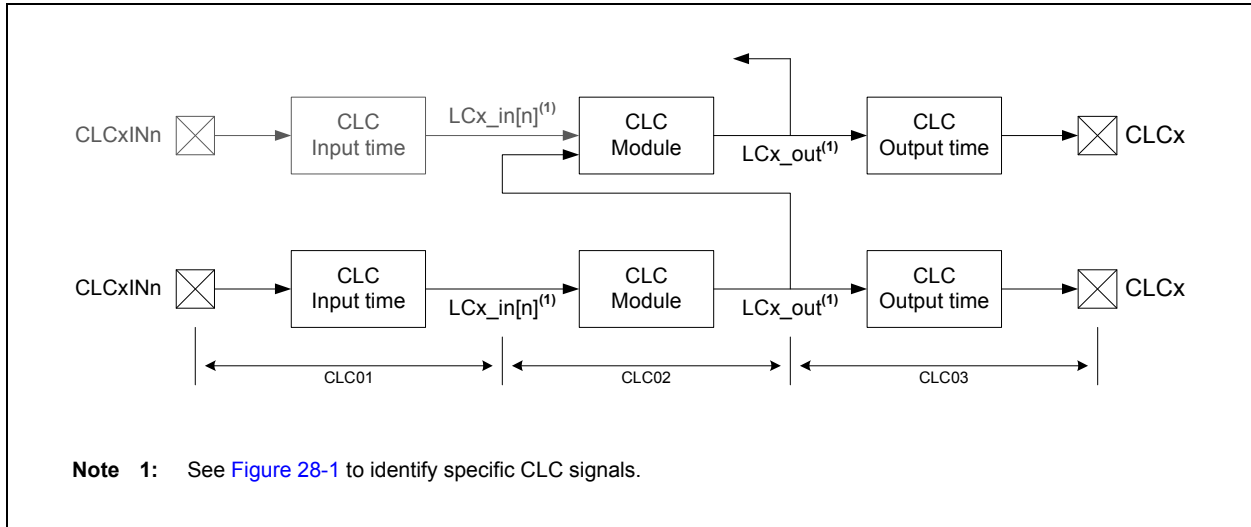
**TABLE 36-13: CAPTURE/COMPARE/PWM REQUIREMENTS (CCP)**

Standard Operating Conditions (unless otherwise stated)								
Param No.	Sym.	Characteristic		Min.	Typ†	Max.	Units	Conditions
CC01*	TccL	CCPx Input Low Time	No Prescaler	$0.5T_{CY} + 20$	—	—	ns	
			With Prescaler	20	—	—	ns	
CC02*	TccH	CCPx Input High Time	No Prescaler	$0.5T_{CY} + 20$	—	—	ns	
			With Prescaler	20	—	—	ns	
CC03*	TccP	CCPx Input Period		$\frac{3 T_{CY} + 40}{N}$	—	—	ns	N = prescale value

\* These parameters are characterized but not tested.

† Data in "Typ" column is at 3.0V, +25°C unless otherwise stated. These parameters are for design guidance only and are not tested.

**FIGURE 36-12: CLC PROPAGATION TIMING**



**TABLE 36-14: CONFIGURATION LOGIC CELL (CLC) CHARACTERISTICS**

Standard Operating Conditions (unless otherwise stated)								
Operating temperature $-40^{\circ}\text{C} \leq T_A \leq +125^{\circ}\text{C}$								
Param. No.	Sym.	Characteristic		Min.	Typ†	Max.	Units	Conditions
CLC01*	TCLCIN	CLC Input Time		—	7	OS17	ns	(Note 1)
CLC02*	TCLC	CLC Module Input to Output Propagation Time		—	24	—	ns	$V_{DD} = 1.8\text{V}$
				—	12	—	ns	$V_{DD} > 3.6\text{V}$
CLC03*	TCLCOUT	CLC Output Time	Rise Time	—	OS18	—	—	(Note 1)
			Fall Time	—	OS19	—	—	(Note 1)
CLC04*	FCLCMAX	CLC Maximum Switching Frequency		—	45	—	MHz	

\* These parameters are characterized but not tested.

† Data in "Typ" column is at 3.0V, +25°C unless otherwise stated. These parameters are for design guidance only and are not tested.

**Note 1:** See [Table 36-10](#) for OS17, OS18 and OS19 rise and fall times.



**TABLE 36-15: ANALOG-TO-DIGITAL CONVERTER (ADC) CHARACTERISTICS<sup>(1,2,3,4)</sup>**

Operating Conditions (unless otherwise stated) VDD = 3.0V, TA = +25°C, Single-Ended, 2 μs TAD, VREF+ = 3V, VREF- = VSS							
Param No.	Sym.	Characteristic	Min.	Typ†	Max.	Units	Conditions
AD01	NR	Resolution	—	—	10	bit	
AD02	EIL	Integral Error	—	—	±1.7	LSb	VREF = 3.0V
AD03	EDL	Differential Error	—	—	±1	LSb	No missing codes, VREF = 3.0V
AD04	E0FF	Offset Error	—	—	±2.5	LSb	VREF = 3.0V
AD05	EGN	Gain Error	—	—	±2.0	LSb	VREF = 3.0V
AD06	VREF	Reference Voltage	1.8	—	VDD	V	VREF = (VREF+ – VREF-)
AD07	VAIN	Full-Scale Range	VSS	—	VREF	V	
AD08	ZAIN	Recommended Impedance of Analog Voltage Source	—	—	10	kΩ	Can go higher if external 0.01 μF capacitor is present on input pin

\* These parameters are characterized but not tested.

† Data in “Typ” column is at 3.0V, +25°C unless otherwise stated. These parameters are for design guidance only and are not tested.

**Note 1:** Total Absolute Error includes integral, differential, offset and gain errors.

**2:** The ADC conversion result never decreases with an increase in the input voltage and has no missing codes.

**3:** ADC VREF is from external VREF+ pin, VDD pin or FVR, whichever is selected as reference input.

**4:** See **Section 37.0 “DC and AC Characteristics Graphs and Charts”** for operating characterization.

**TABLE 36-16: ADC CONVERSION REQUIREMENTS**

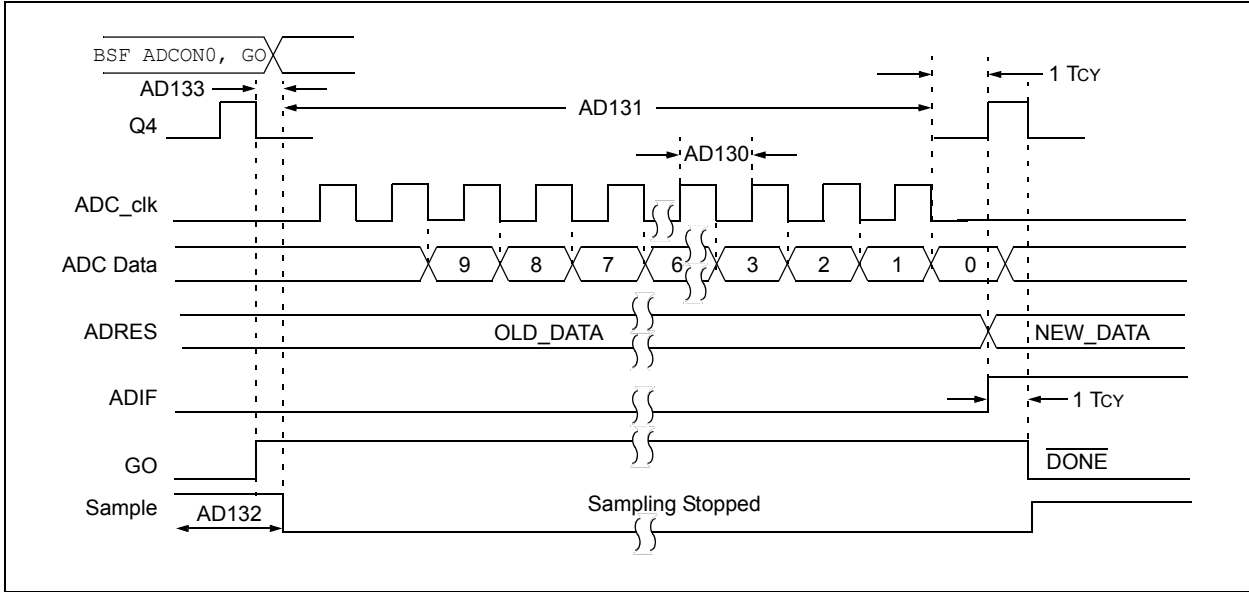
Standard Operating Conditions (unless otherwise stated)							
Param No.	Sym.	Characteristic	Min.	Typ†	Max.	Units	Conditions
AD130*	TAD	ADC Clock Period (TADC)	1.0	—	9.0	μs	FOSC-based
		ADC Internal FRC Oscillator Period (TFRC)	1.0	2	6.0	μs	ADCS<1:0> = 11 (ADC FRC mode)
AD131	TCNV	Conversion Time (not including Acquisition Time) <sup>(1)</sup>	—	11	—	TAD	Set GO/DONE bit to conversion complete
AD132*	TACQ	Acquisition Time	—	5.0	—	μs	
AD133*	THCD	Holding Capacitor Disconnect Time	—	1/2 TAD	—		ADCS<2:0> ≠ x11 (FOSC-based)
			—	1/2 TAD + 1 Tcy	—		ADCS<2:0> = x11 (FRC-based)

\* These parameters are characterized but not tested.

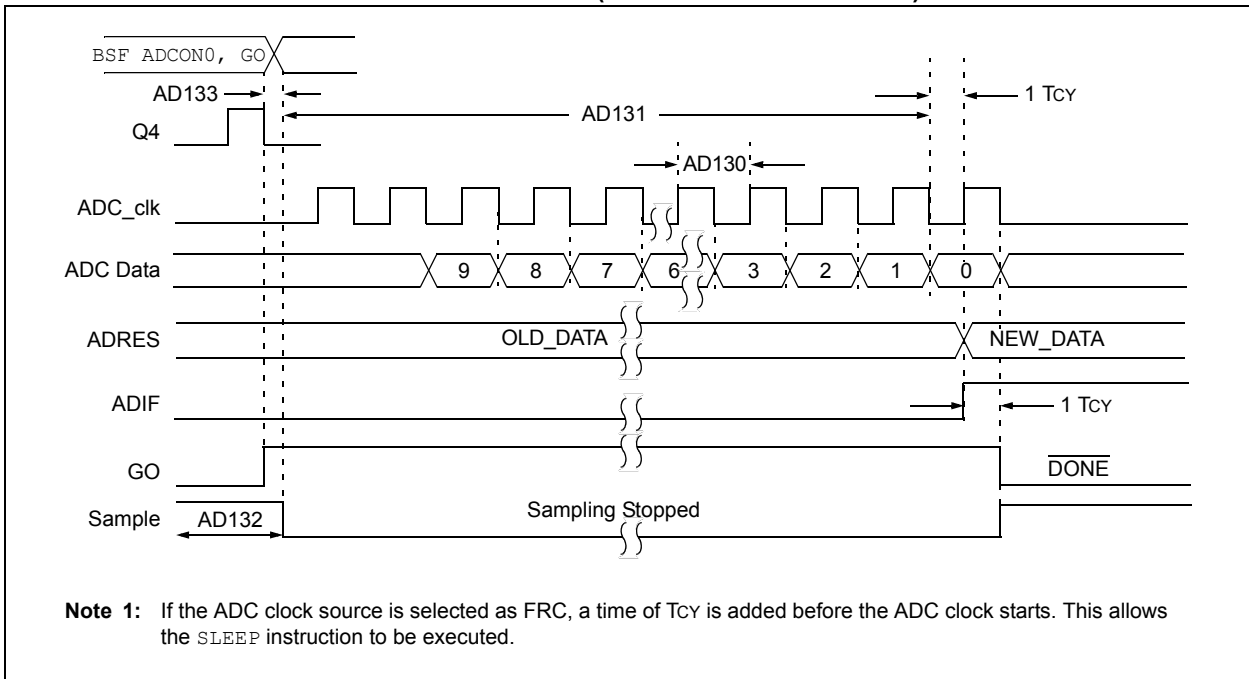
† Data in “Typ” column is at 3.0V, +25°C unless otherwise stated. These parameters are for design guidance only and are not tested.

**Note 1:** The ADRES register may be read on the following Tcy cycle.

**FIGURE 36-13: ADC CONVERSION TIMING (ADC CLOCK Fosc-BASED)**



**FIGURE 36-14: ADC CONVERSION TIMING (ADC CLOCK FROM FRC)**



**TABLE 36-17: OPERATIONAL AMPLIFIER (OPA)**

Operating Conditions (unless otherwise stated) V <sub>DD</sub> = 3.0V, T <sub>A</sub> = +25°C, OPAxSP = 1 (High GBWP mode)							
Param No.	Symbol	Parameters	Min.	Typ.	Max.	Units	Conditions
OPA01*	GBWP	Gain Bandwidth Product	—	3	—	MHz	
OPA02*	T <sub>ON</sub>	Turn-on Time	—	10	—	μs	
OPA03*	PM	Phase Margin	—	40	—	degrees	
OPA04*	SR	Slew Rate	—	3	—	V/μs	
OPA05	OFF	Offset	—	±3	±9	mV	
OPA06	CMRR	Common-Mode Rejection Ratio	52	70	—	dB	
OPA07*	AOL	Open-Loop Gain	—	90	—	dB	
OPA08	V <sub>ICM</sub>	Input Common-Mode Voltage	0	—	V <sub>DD</sub>	V	V <sub>DD</sub> > 2.5V
OPA09*	PSRR	Power Supply Rejection Ratio	—	80	—	dB	
OPA10*	HZ	High-Impedance On/Off Time	—	50	—	ns	
OPA11*	ISC	Short Circuit Current	—	50	—	mA	

\* These parameters are characterized but not tested.

**TABLE 36-18: PROGRAMMABLE RAMP GENERATOR (PRG) SPECIFICATIONS**

Operating Conditions (unless otherwise stated) V <sub>DD</sub> = 3.0V, T <sub>A</sub> = +25°C (unless otherwise stated)							
Param No.	Sym.	Characteristics	Min.	Typ.	Max.	Units	Comments
PRG01	RRR	Rising Ramp Rate	—	1	—	V/μs	PRGxCON2 = 10h
PRG02	FRR	Falling Ramp Rate	—	1	—	V/μs	PRGxCON2 = 10h

\* These parameters are characterized but not tested.

**TABLE 36-19: COMPARATOR SPECIFICATIONS**

Operating Conditions (unless otherwise stated) V <sub>DD</sub> = 3.0V, T <sub>A</sub> = +25°C See Section 37.0 “DC and AC Characteristics Graphs and Charts” for operating characterization.							
Param No.	Sym.	Characteristics	Min.	Typ.	Max.	Units	Comments
CM01	V <sub>IOFF</sub>	Input Offset Voltage	—	±2.5	±5	mV	V <sub>ICM</sub> = V <sub>DD</sub> /2
CM02	V <sub>ICM</sub>	Input Common-Mode Voltage	0	—	V <sub>DD</sub>	V	
CM03	CMRR	Common-Mode Rejection Ratio	35	50	—	dB	
CM04A	T <sub>RESP</sub> <sup>(1)</sup>	Response Time Rising Edge	—	60	125	ns	Normal Power mode
CM04B		Response Time Falling Edge	—	60	110	ns	Normal Power mode
CM04C		Response Time Rising Edge	—	85	—	ns	Low-Power mode
CM04D		Response Time Falling Edge	—	85	—	ns	Low-Power mode
CM05*	T <sub>MC2OV</sub>	Comparator Mode Change to Output Valid*	—	—	10	μs	
CM06	CHYSTER	Comparator Hysteresis	20	45	75	mV	CxHYS = 1

\* These parameters are characterized but not tested.

**Note 1:** Response time measured with one comparator input at V<sub>DD</sub>/2, while the other input transitions from V<sub>SS</sub> to V<sub>DD</sub>.

# PIC16(L)F1764/5/8/9

**TABLE 36-20: 10-BIT DIGITAL-TO-ANALOG CONVERTER (DAC) SPECIFICATIONS**

Operating Conditions (unless otherwise stated)							
V <sub>DD</sub> = 3.0V, T <sub>A</sub> = +25°C							
See Section 37.0 “DC and AC Characteristics Graphs and Charts” for operating characterization.							
Param No.	Sym.	Characteristics	Min.	Typ.	Max.	Units	Comments
DAC01*	CLSB	Step-Size	—	V <sub>DD</sub> /1024	—	V	
DAC02	CINL	Integral Error <sup>(2)</sup>	—	—	±1.5	LSb	For codes: 0x004 to 0x3FB
DAC03	CDNL	Differential Error <sup>(2)</sup>	—	—	±1	LSb	
DAC04	COFF	Offset Error <sup>(2)</sup>	—	—	±3	LSb	
DAC05	CGN	Gain Error <sup>(2)</sup>	—	—	±3	LSb	
DAC06*	CR	Unit Resistor Value (R)	—	300	—	Ω	
DAC07*	CST	Settling Time <sup>(1)</sup>	—	—	10	μs	

\* These parameters are characterized but not tested.

**Note 1:** Settling time measured while DACR<9:0> transitions from 0x000 to 0x3FF.

**2:** Buffered by op amp in unity gain.

**TABLE 36-21: 5-BIT DIGITAL-TO-ANALOG CONVERTER (DAC) SPECIFICATIONS**

Operating Conditions (unless otherwise stated)							
V <sub>DD</sub> = 3.0V, T <sub>A</sub> = +25°C							
See Section 37.0 “DC and AC Characteristics Graphs and Charts” for operating characterization.							
Param No.	Sym.	Characteristics	Min.	Typ.	Max.	Units	Comments
DAC10*	CLSB	Step-Size	—	V <sub>DD</sub> /32	—	V	
DAC11	CACC	Absolute Accuracy <sup>(2)</sup>	—	—	±0.5	LSb	
DAC12*	CR	Unit Resistor Value (R)	—	6000	—	Ω	
DAC13*	CST	Settling Time <sup>(1)</sup>	—	—	10	μs	

\* These parameters are characterized but not tested.

**Note 1:** Settling time measured while DACR<4:0> transitions from 0x00 to 0x1F.

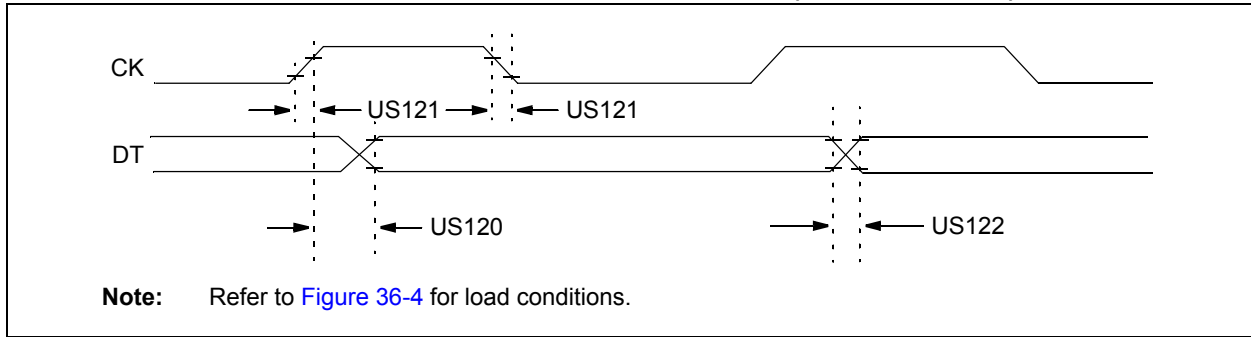
**2:** Buffered by op amp in unity gain.

**TABLE 36-22: ZERO-CROSS PIN SPECIFICATIONS**

Operating Conditions (unless otherwise stated)							
V <sub>DD</sub> = 3.0V, T <sub>A</sub> = +25°C							
Param. No.	Sym.	Characteristics	Min.	Typ.	Max.	Units	Comments
ZC01	ZCPINV	Voltage on Zero-Cross Pin	—	0.75	—	V	
ZC02	ZCDRV	Maximum Source or Sink Current	—	—	600	μA	
ZC04	ZCISW	Response Time Rising Edge	—	1	—	μs	
		Response Time Falling Edge	—	1	—	μs	
ZC05	ZCOUT	Response Time Rising Edge	—	1	—	μs	
		Response Time Falling Edge	—	1	—	μs	

\* These parameters are characterized but not tested.

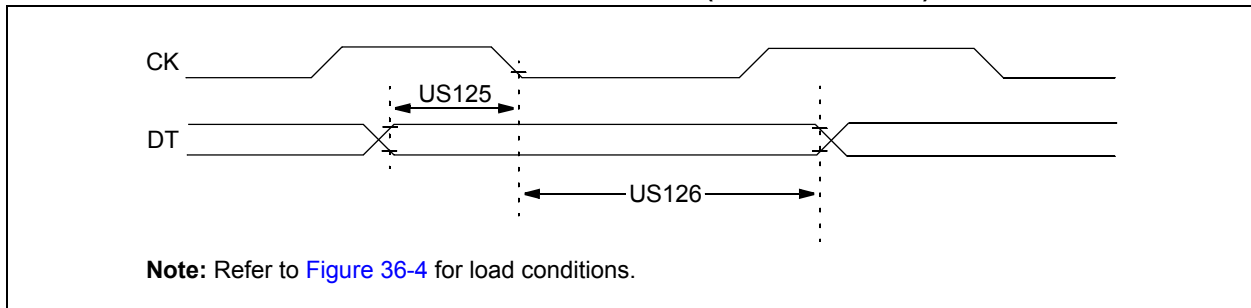
**FIGURE 36-15: EUSART SYNCHRONOUS TRANSMISSION (MASTER/SLAVE) TIMING**



**TABLE 36-23: EUSART SYNCHRONOUS TRANSMISSION REQUIREMENTS**

Standard Operating Conditions (unless otherwise stated)						
Param. No.	Symbol	Characteristic	Min.	Max.	Units	Conditions
US120	TCKH2DTV	SYNC XMIT (Master and Slave) Clock High to Data-out Valid	—	80	ns	$3.0V \leq V_{DD} \leq 5.5V$
			—	100	ns	$1.8V \leq V_{DD} \leq 5.5V$
US121	TCKRF	Clock Out Rise Time and Fall Time (Master mode)	—	45	ns	$3.0V \leq V_{DD} \leq 5.5V$
			—	50	ns	$1.8V \leq V_{DD} \leq 5.5V$
US122	TDTRF	Data-out Rise Time and Fall Time	—	45	ns	$3.0V \leq V_{DD} \leq 5.5V$
			—	50	ns	$1.8V \leq V_{DD} \leq 5.5V$

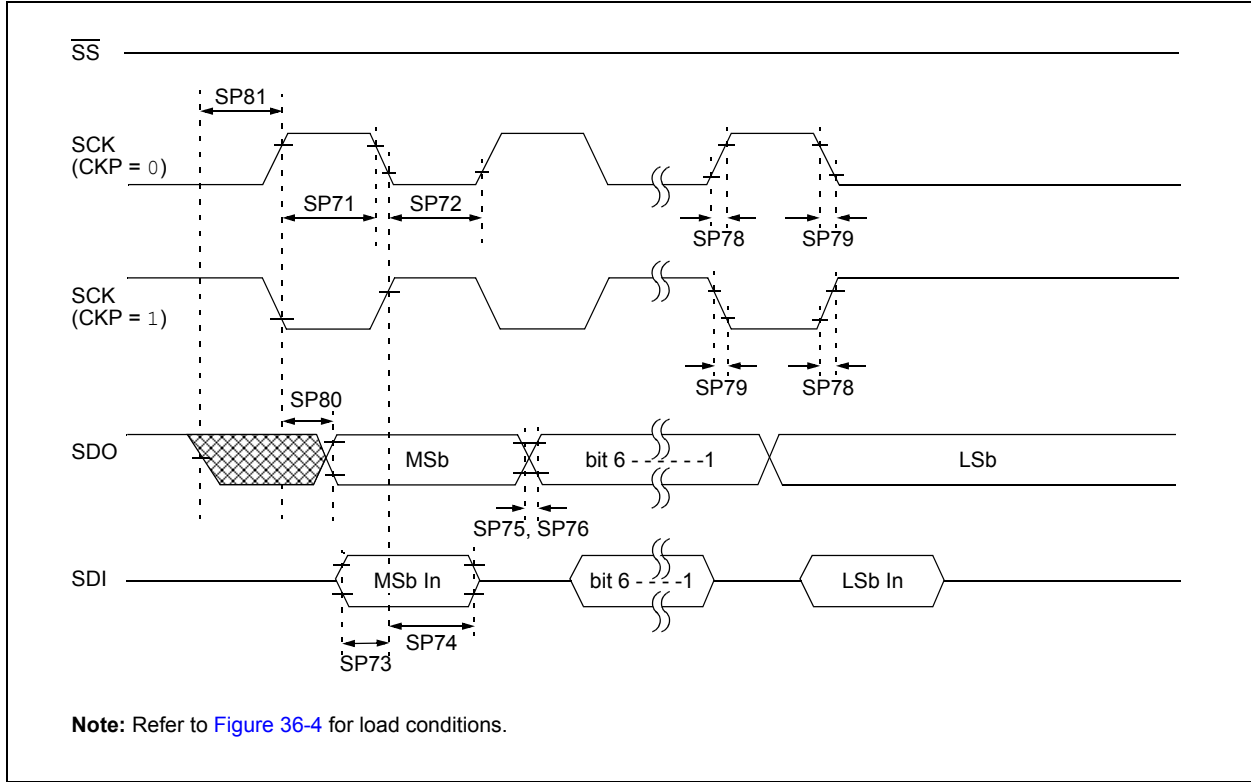
**FIGURE 36-16: EUSART SYNCHRONOUS RECEIVE (MASTER/SLAVE) TIMING**



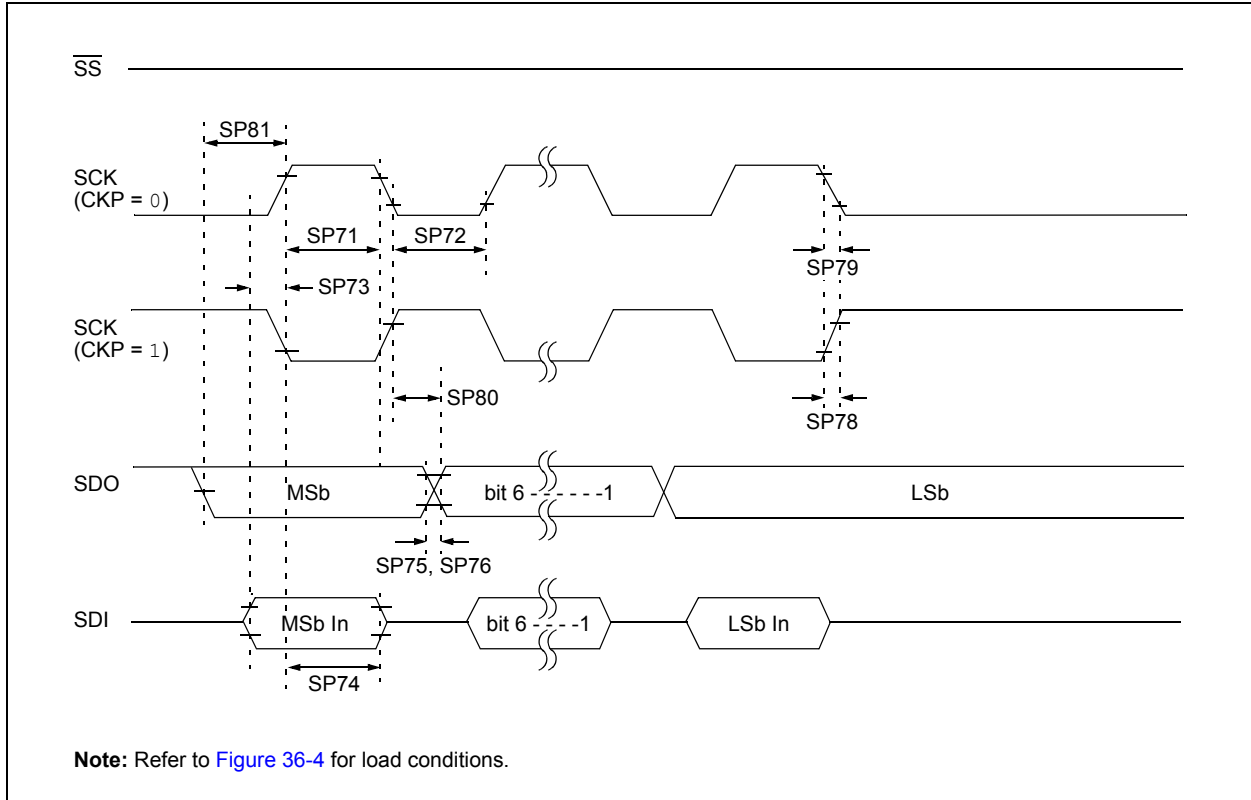
**TABLE 36-24: EUSART SYNCHRONOUS RECEIVE REQUIREMENTS**

Standard Operating Conditions (unless otherwise stated)						
Param. No.	Symbol	Characteristic	Min.	Max.	Units	Conditions
US125	TDTV2CKL	SYNC RCV (Master and Slave) Data-Setup before CK ↓ (DT hold time)	10	—	ns	
US126	TCKL2DTL	Data-hold after CK ↓ (DT hold time)	15	—	ns	

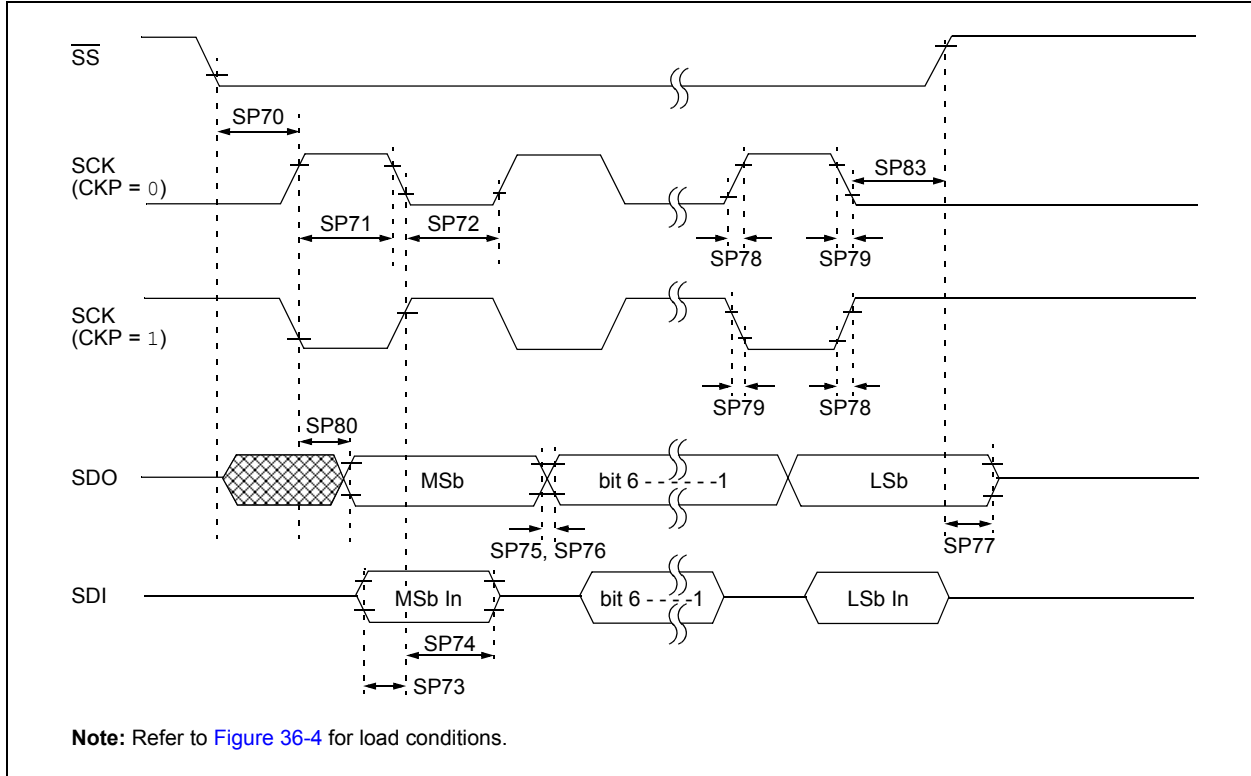
**FIGURE 36-17: SPI MASTER MODE TIMING (CKE = 0, SMP = 0)**



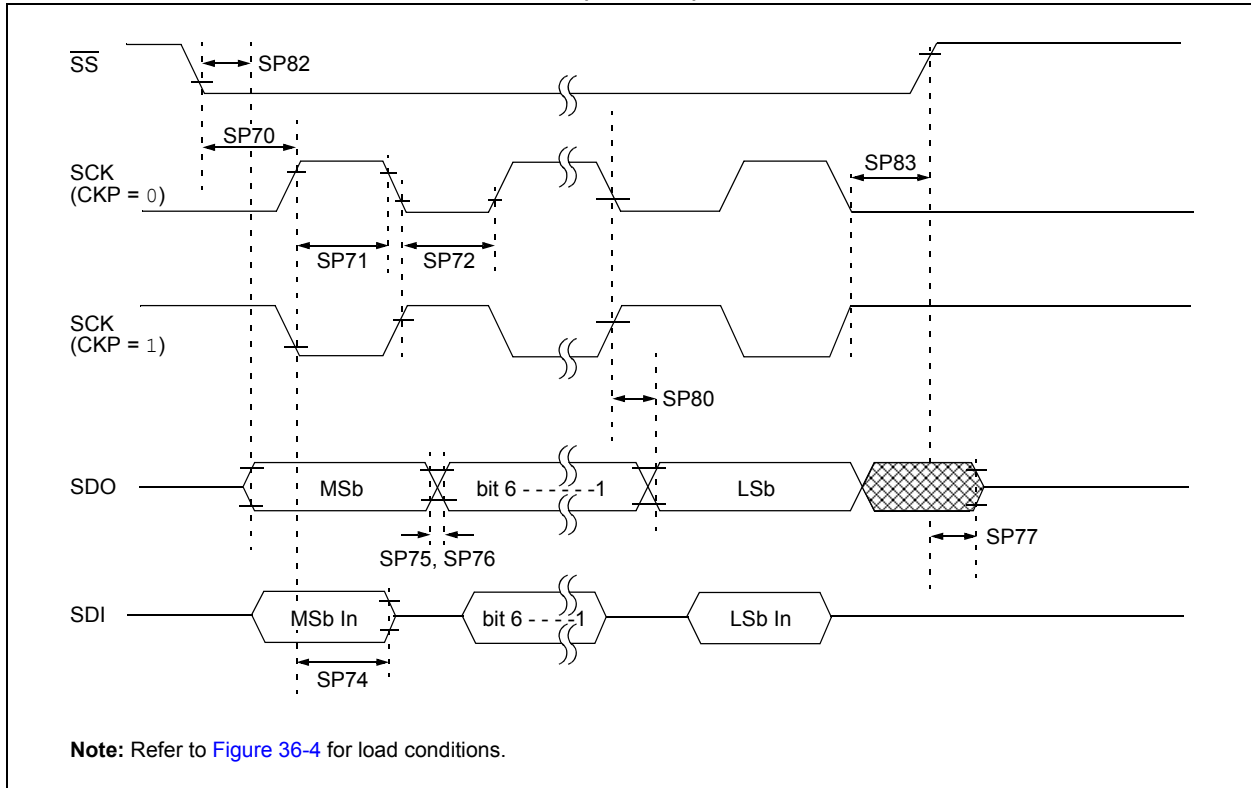
**FIGURE 36-18: SPI MASTER MODE TIMING (CKE = 1, SMP = 1)**



**FIGURE 36-19: SPI SLAVE MODE TIMING (CKE = 0)**



**FIGURE 36-20: SPI SLAVE MODE TIMING (CKE = 1)**



**TABLE 36-25: SPI MODE REQUIREMENTS**

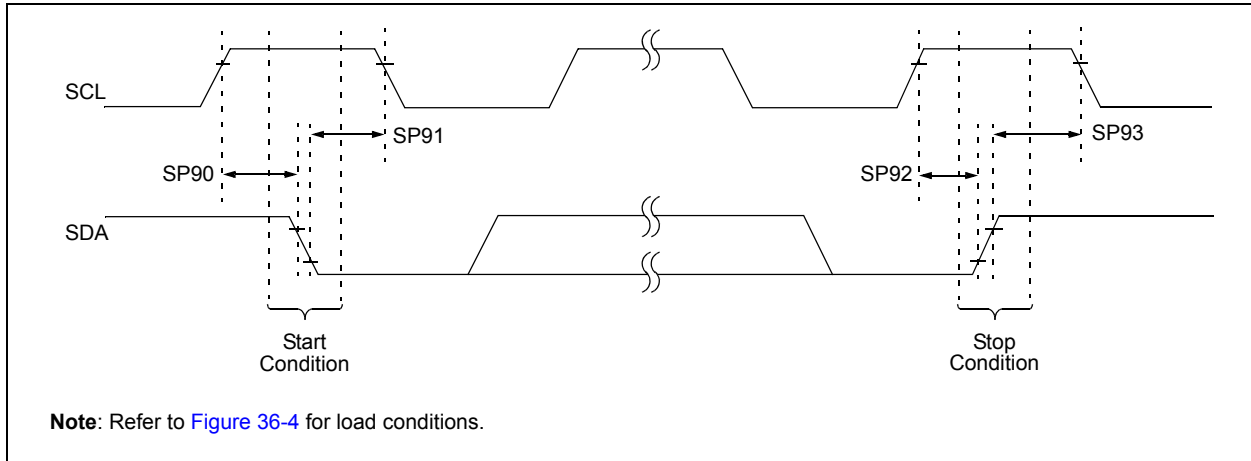
Standard Operating Conditions (unless otherwise stated)							
Param No.	Symbol	Characteristic	Min.	Typ†	Max.	Units	Conditions
SP70*	TssL2scH, TssL2scL	$\overline{SS}\downarrow$ to SCK $\downarrow$ or SCK $\uparrow$ Input	T <sub>cy</sub>	—	—	ns	
SP71*	Tsch	SCK Input High Time (Slave mode)	T <sub>cy</sub> + 20	—	—	ns	
SP72*	TscL	SCK Input Low Time (Slave mode)	T <sub>cy</sub> + 20	—	—	ns	
SP73*	TdIV2scH, TdIV2scL	Setup Time of SDI Data Input to SCK Edge	100	—	—	ns	
SP74*	Tsch2dIL, TscL2dIL	Hold Time of SDI Data Input to SCK Edge	100	—	—	ns	
SP75*	TdoR	SDO Data Output Rise Time	—	10	25	ns	3.0V ≤ V <sub>DD</sub> ≤ 5.5V
			—	25	50	ns	1.8V ≤ V <sub>DD</sub> ≤ 5.5V
SP76*	TdoF	SDO Data Output Fall Time	—	10	25	ns	
SP77*	TssH2doZ	$\overline{SS}\uparrow$ to SDO Output High-Impedance	10	—	50	ns	
SP78*	TscR	SCK Output Rise Time (Master mode)	—	10	25	ns	3.0V ≤ V <sub>DD</sub> ≤ 5.5V
			—	25	50	ns	1.8V ≤ V <sub>DD</sub> ≤ 5.5V
SP79*	TscF	SCK Output Fall Time (Master mode)	—	10	25	ns	
SP80*	Tsch2doV, TscL2doV	SDO Data Output Valid after SCK Edge	—	—	50	ns	3.0V ≤ V <sub>DD</sub> ≤ 5.5V
			—	—	145	ns	1.8V ≤ V <sub>DD</sub> ≤ 5.5V
SP81*	TdoV2scH, TdoV2scL	SDO Data Output Setup to SCK Edge	1 T <sub>cy</sub>	—	—	ns	
SP82*	TssL2doV	SDO Data Output Valid after $\overline{SS}\downarrow$ Edge	—	—	50	ns	
SP83*	Tsch2ssH, TscL2ssH	$\overline{SS}\uparrow$ after SCK Edge	1.5 T <sub>cy</sub> + 40	—	—	ns	

\* These parameters are characterized but not tested.

† Data in "Typ" column is at 3.0V, +25°C unless otherwise stated. These parameters are for design guidance only and are not tested.



**FIGURE 36-21: I<sup>2</sup>C BUS START/STOP BITS TIMING**

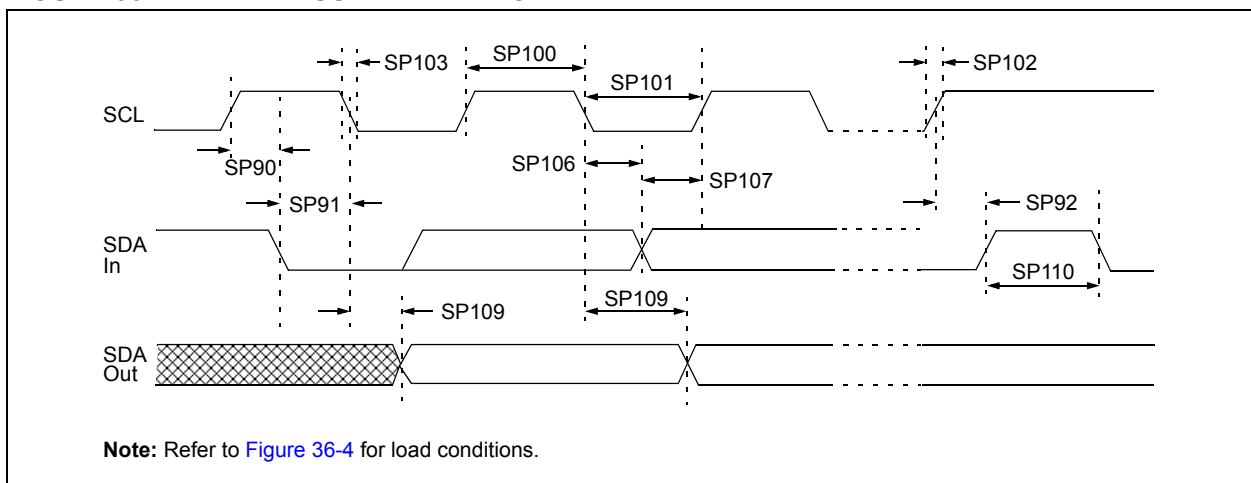


**TABLE 36-26: I<sup>2</sup>C BUS START/STOP BITS REQUIREMENTS**

Standard Operating Conditions (unless otherwise stated)								
Param No.	Symbol	Characteristic		Min.	Typ	Max.	Units	Conditions
SP90*	TSU:STA	Start Condition Setup Time	100 kHz mode	4700	—	—	ns	Only relevant for Repeated Start condition
			400 kHz mode	600	—	—		
SP91*	THD:STA	Start Condition Hold Time	100 kHz mode	4000	—	—	ns	After this period, the first clock pulse is generated
			400 kHz mode	600	—	—		
SP92*	TSU:STO	Stop Condition Setup Time	100 kHz mode	4700	—	—	ns	
			400 kHz mode	600	—	—		
SP93	THD:STO	Stop Condition Hold Time	100 kHz mode	4000	—	—	ns	
			400 kHz mode	600	—	—		

\* These parameters are characterized but not tested.

**FIGURE 36-22: I<sup>2</sup>C BUS DATA TIMING**



**TABLE 36-27: I<sup>2</sup>C BUS DATA REQUIREMENTS**

Standard Operating Conditions (unless otherwise stated)							
Param. No.	Symbol	Characteristic	Min.	Max.	Units	Conditions	
SP100*	THIGH	Clock High Time	100 kHz mode	4.0	—	μs	Device must operate at a minimum of 1.5 MHz
			400 kHz mode	0.6	—	μs	Device must operate at a minimum of 10 MHz
			SSP module	1.5 T <sub>CY</sub>	—	T <sub>CY</sub>	
SP101*	TLOW	Clock Low Time	100 kHz mode	4.7	—	μs	Device must operate at a minimum of 1.5 MHz
			400 kHz mode	1.3	—	μs	Device must operate at a minimum of 10 MHz
			SSP module	1.5 T <sub>CY</sub>	—	T <sub>CY</sub>	
SP102*	TR	SDA and SCL Rise Time	100 kHz mode	—	1000	ns	
			400 kHz mode	20 + 0.1 C <sub>B</sub>	300	ns	C <sub>B</sub> is specified to be from 10-400 pF
SP103*	TF	SDA and SCL Fall Time	100 kHz mode	—	250	ns	
			400 kHz mode	20 + 0.1 C <sub>B</sub>	250	ns	C <sub>B</sub> is specified to be from 10-400 pF
SP106*	THD:DAT	Data Input Hold Time	100 kHz mode	0	—	ns	
			400 kHz mode	0	0.9	μs	
SP107*	TSU:DAT	Data Input Setup Time	100 kHz mode	250	—	ns	<b>(Note 2)</b>
			400 kHz mode	100	—	ns	
SP109*	TAA	Output Valid from Clock	100 kHz mode	—	3500	ns	<b>(Note 1)</b>
			400 kHz mode	—	—	ns	
SP110*	TBUF	Bus Free Time	100 kHz mode	4.7	—	μs	Time the bus must be free before a new transmission can start
			400 kHz mode	1.3	—	μs	
SP111	C <sub>B</sub>	Bus Capacitive Loading	—	400	pF		

\* These parameters are characterized but not tested.

**Note 1:** As a transmitter, the device must provide this internal minimum delay time to bridge the undefined region (min. 300 ns) of the falling edge of SCL to avoid unintended generation of Start or Stop conditions.

**2:** A Fast mode (400 kHz) I<sup>2</sup>C bus device can be used in a Standard mode (100 kHz) I<sup>2</sup>C bus system, but the requirement, TSU:DAT ≥ 250 ns, must then be met. This will automatically be the case if the device does not stretch the low period of the SCL signal. If such a device does stretch the low period of the SCL signal, it must output the next data bit to the SDA line, TR max. + TSU:DAT = 1000 + 250 = 1250 ns (according to the Standard mode I<sup>2</sup>C bus specification), before the SCL line is released.

## 37.0 DC AND AC CHARACTERISTICS GRAPHS AND CHARTS

The graphs and tables provided in this section are for **design guidance** and are **not tested**.

In some graphs or tables, the data presented are **outside specified operating range** (i.e., outside specified V<sub>DD</sub> range). This is for **information only** and devices are ensured to operate properly only within the specified range.

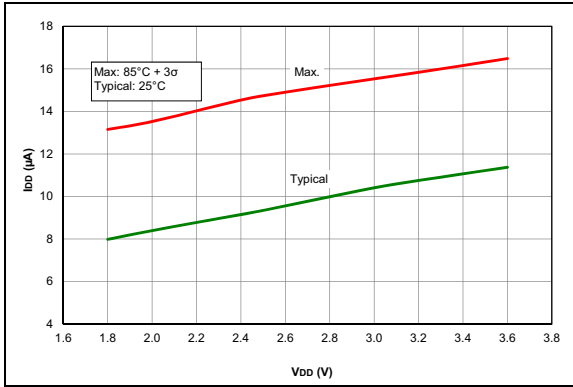
Unless otherwise noted, all graphs apply to both the L and LF devices.

<p><b>Note:</b> The graphs and tables provided following this note are a statistical summary based on a limited number of samples and are provided for informational purposes only. The performance characteristics listed herein are not tested or guaranteed. In some graphs or tables, the data presented may be outside the specified operating range (e.g., outside specified power supply range) and therefore, outside the warranted range.</p>
--

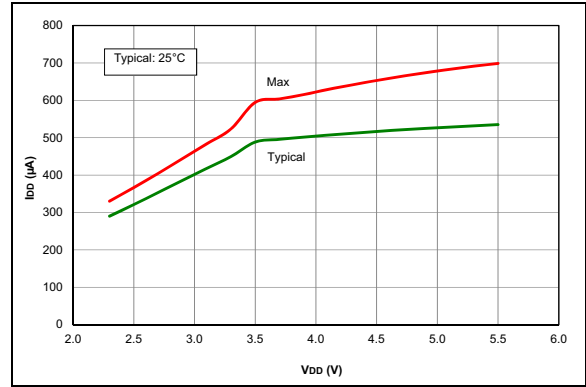
**“Typical”** represents the mean of the distribution at 25°C. **“Maximum”, “Max.”, “Minimum” or “Min.”** represents (mean + 3σ) or (mean - 3σ) respectively, where σ is a standard deviation, over each temperature range.

# PIC16(L)F1764/5/8/9

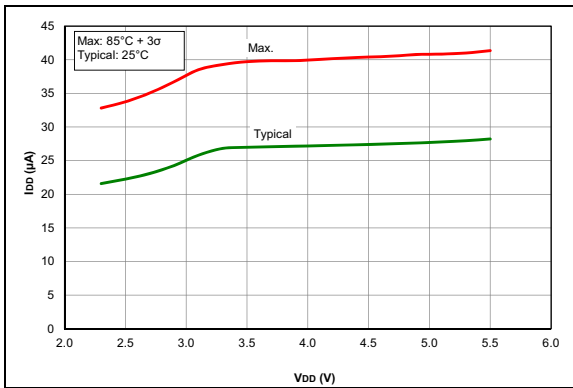
**Note:** Unless otherwise noted,  $V_{IN} = 5V$ ,  $F_{OSC} = 300\text{ kHz}$ ,  $C_{IN} = 0.1\ \mu F$ ,  $T_A = 25^\circ C$ .



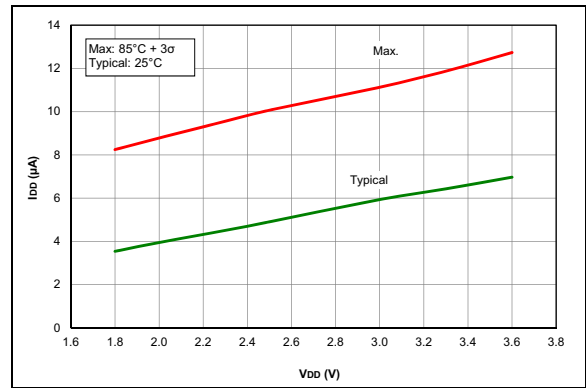
**FIGURE 37-1:**  $I_{DD}$ , LP Oscillator Mode,  $F_{osc} = 32\text{ kHz}$ , PIC16LF1764/5/8/9 Only.



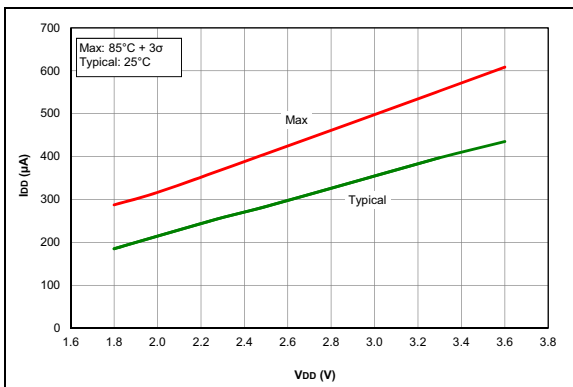
**FIGURE 37-4:**  $I_{DD}$ , XT Oscillator, 4 MHz, PIC16F1764/5/8/9 Only.



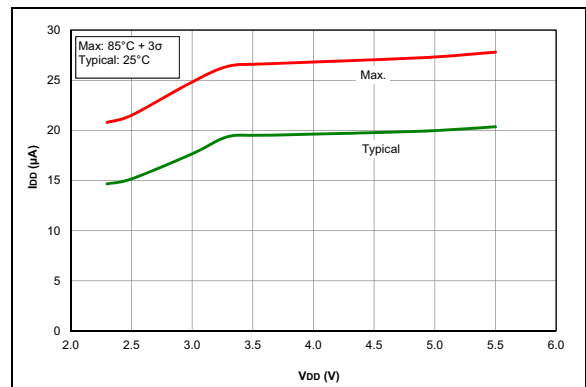
**FIGURE 37-2:**  $I_{DD}$ , LP Oscillator Mode,  $F_{osc} = 32\text{ kHz}$ , PIC16F1764/5/8/9 Only.



**FIGURE 37-5:**  $I_{DD}$ , EC Oscillator LP Mode,  $F_{osc} = 32\text{ kHz}$ , PIC16LF1764/5/8/9 Only.



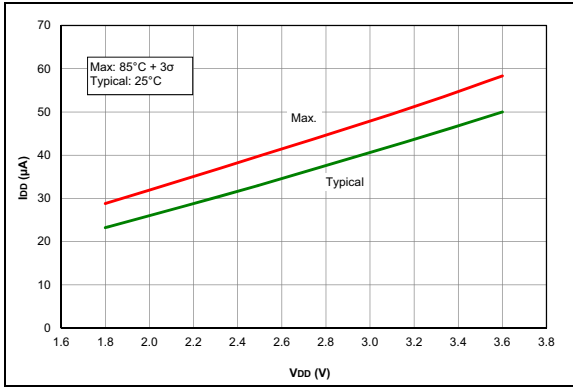
**FIGURE 37-3:**  $I_{DD}$ , XT Oscillator 4 MHz, PIC16LF1764/5/8/9 Only.



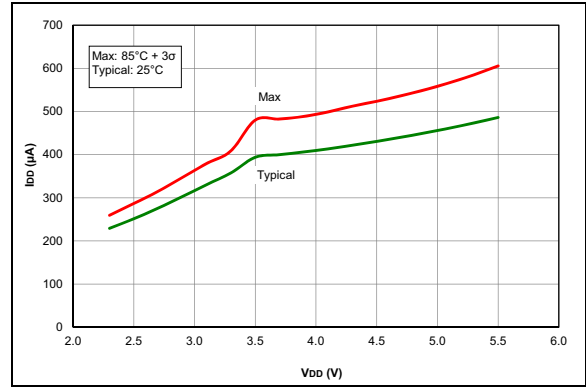
**FIGURE 37-6:**  $I_{DD}$ , EC Oscillator LP Mode,  $F_{osc} = 32\text{ kHz}$ , PIC16F1764/5/8/9 Only.

# PIC16(L)F1764/5/8/9

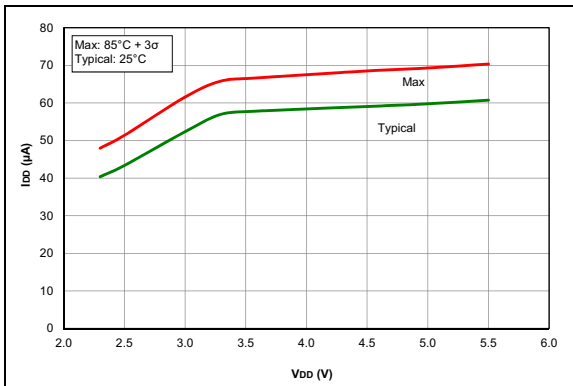
**Note:** Unless otherwise noted,  $V_{IN} = 5V$ ,  $F_{OSC} = 300\text{ kHz}$ ,  $C_{IN} = 0.1\ \mu\text{F}$ ,  $T_A = 25^\circ\text{C}$ .



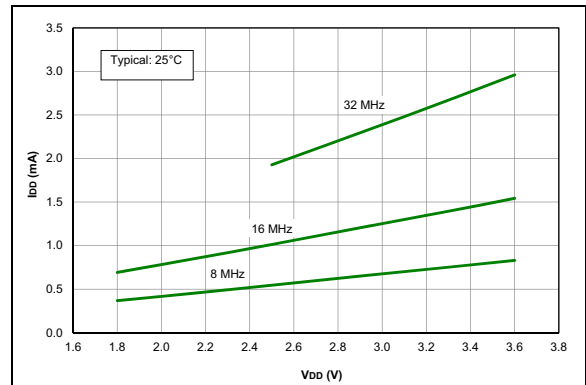
**FIGURE 37-7:**  $I_{DD}$ , EC Oscillator LP Mode,  $F_{osc} = 500\text{ kHz}$ , PIC16LF1764/5/8/9 Only.



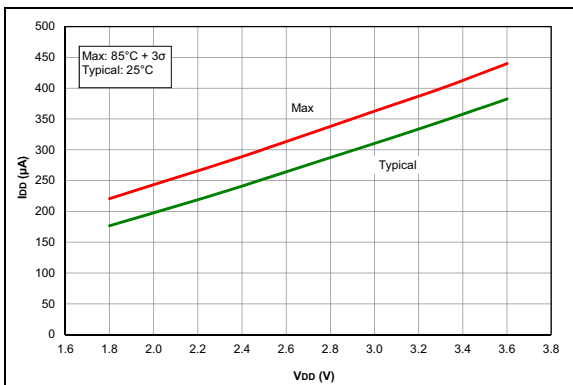
**FIGURE 37-10:**  $I_{DD}$  Typical, EC Oscillator MP Mode,  $F_{osc} = 4\text{ MHz}$ , PIC16F1764/5/8/9 Only.



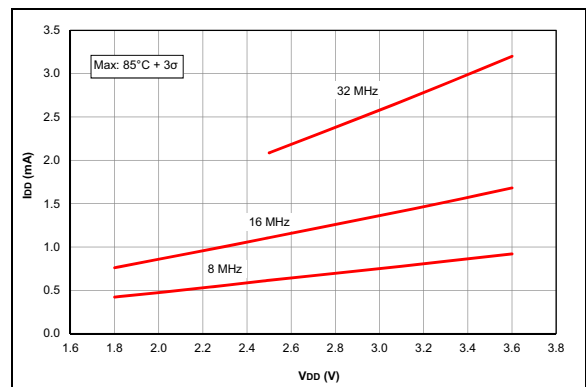
**FIGURE 37-8:**  $I_{DD}$ , EC Oscillator LP Mode,  $F_{osc} = 500\text{ kHz}$ , PIC16F1764/5/8/9 Only.



**FIGURE 37-11:**  $I_{DD}$  Typical, EC Oscillator HP Mode, PIC16LF1764/5/8/9 Only.



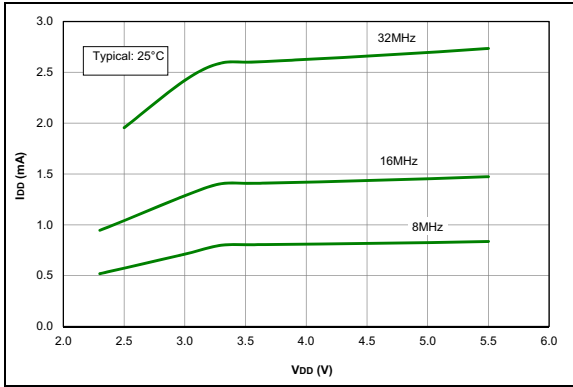
**FIGURE 37-9:**  $I_{DD}$  Typical, EC Oscillator MP Mode,  $F_{osc} = 4\text{ MHz}$ , PIC16LF1764/5/8/9 Only.



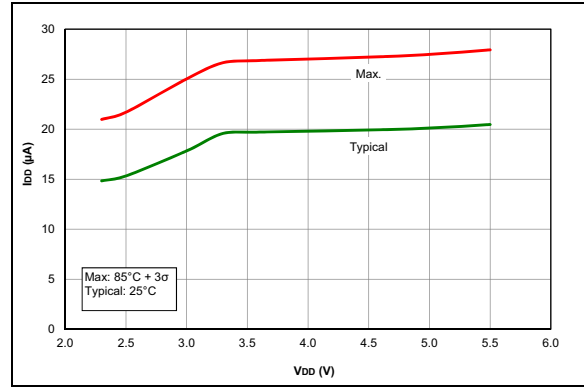
**FIGURE 37-12:**  $I_{DD}$  Maximum, EC Oscillator HP Mode, PIC16LF1764/5/8/9 Only.

# PIC16(L)F1764/5/8/9

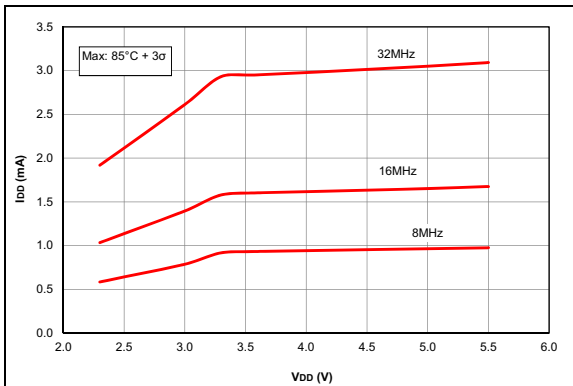
**Note:** Unless otherwise noted,  $V_{IN} = 5V$ ,  $F_{OSC} = 300\text{ kHz}$ ,  $C_{IN} = 0.1\ \mu F$ ,  $T_A = 25^\circ C$ .



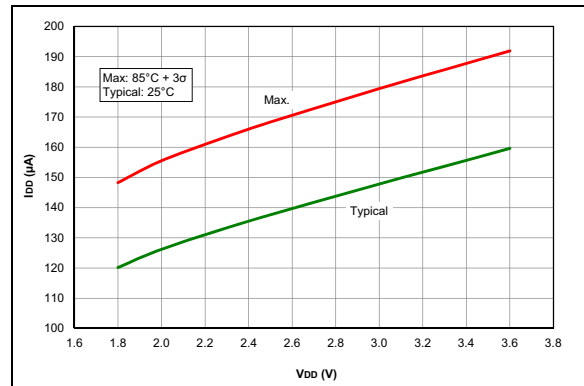
**FIGURE 37-13:**  $I_{DD}$  Typical, EC Oscillator HP Mode, PIC16F1764/5/8/9 Only.



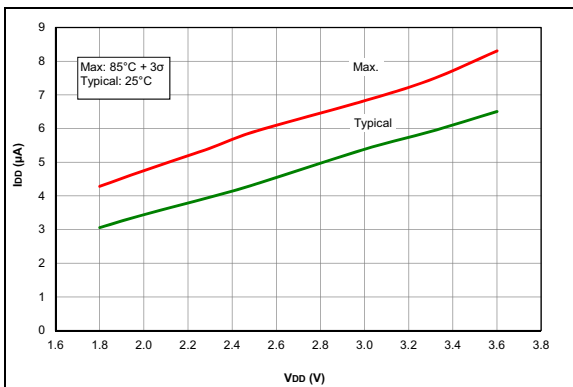
**FIGURE 37-16:**  $I_{DD}$  LFINTOSC Mode,  $F_{osc} = 31\text{ kHz}$ , PIC16F1764/5/8/9 Only.



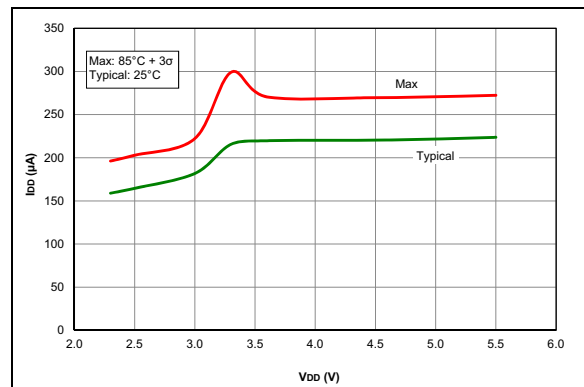
**FIGURE 37-14:**  $I_{DD}$  Maximum, EC Oscillator HP Mode, PIC16F1764/5/8/9 Only.



**FIGURE 37-17:**  $I_{DD}$ , MFINTOSC Mode,  $F_{osc} = 500\text{ kHz}$ , PIC16LF1764/5/8/9 Only.



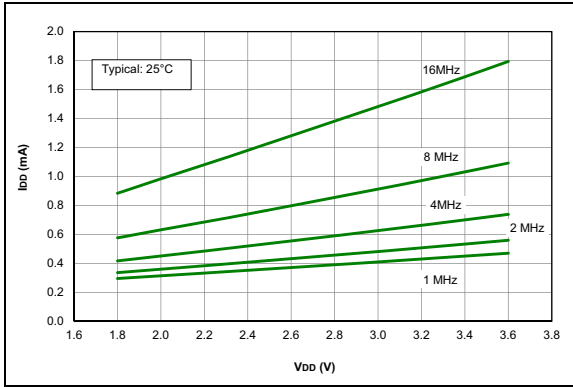
**FIGURE 37-15:**  $I_{DD}$  LFINTOSC Mode,  $F_{osc} = 31\text{ kHz}$ , PIC16LF1764/5/8/9 Only.



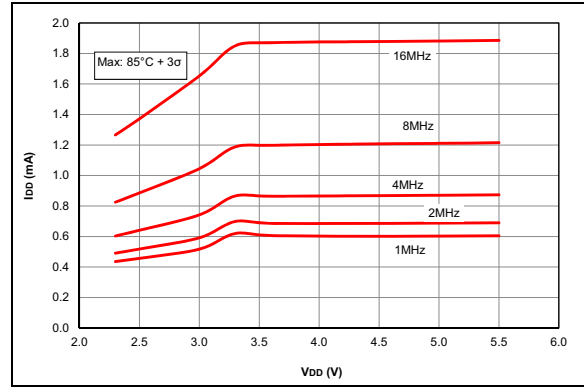
**FIGURE 37-18:**  $I_{DD}$ , MFINTOSC Mode,  $F_{osc} = 500\text{ kHz}$ , PIC16F1764/5/8/9 Only.

# PIC16(L)F1764/5/8/9

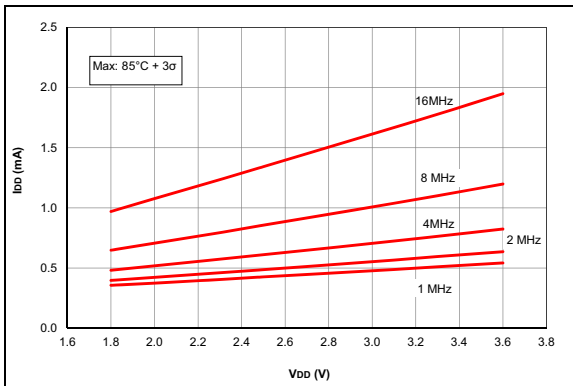
**Note:** Unless otherwise noted,  $V_{IN} = 5V$ ,  $F_{OSC} = 300\text{ kHz}$ ,  $C_{IN} = 0.1\ \mu\text{F}$ ,  $T_A = 25^\circ\text{C}$ .



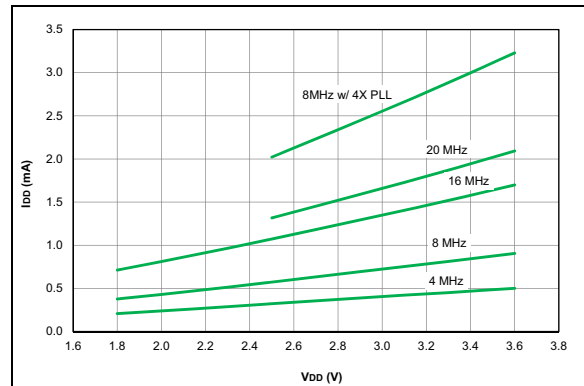
**FIGURE 37-19:**  $I_{DD}$  Typical, HFINTOSC Mode, PIC16LF1764/5/8/9 Only.



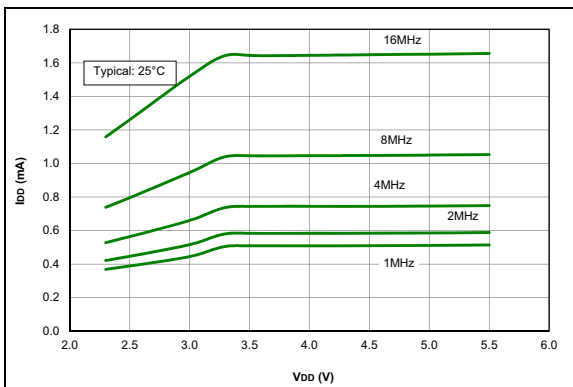
**FIGURE 37-22:**  $I_{DD}$  Maximum, HFINTOSC Mode, PIC16F1764/5/8/9 Only.



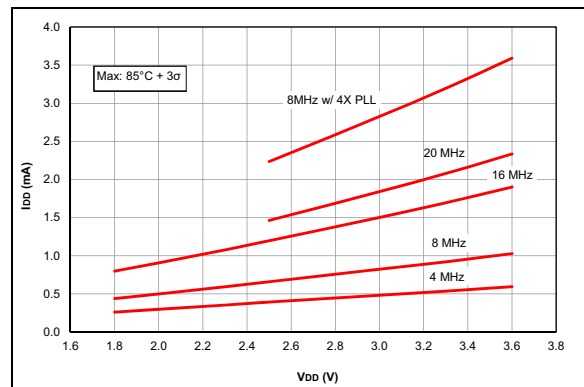
**FIGURE 37-20:**  $I_{DD}$  Maximum, HFINTOSC Mode, PIC16LF1764/5/8/9 Only.



**FIGURE 37-23:**  $I_{DD}$  Typical, HS Oscillator,  $25^\circ\text{C}$ , PIC16LF1764/5/8/9 Only.



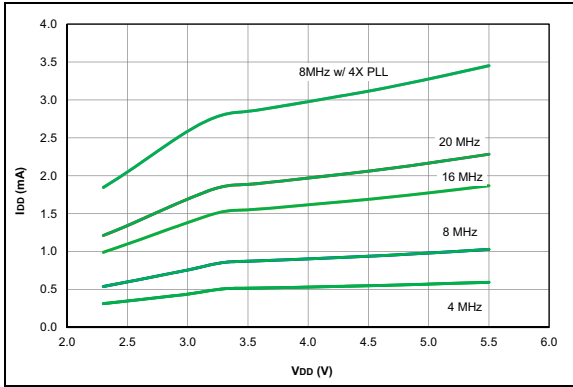
**FIGURE 37-21:**  $I_{DD}$  Typical, HFINTOSC Mode, PIC16F1764/5/8/9 Only.



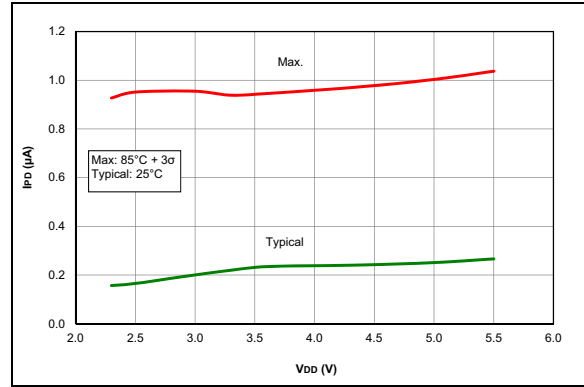
**FIGURE 37-24:**  $I_{DD}$  Maximum, HS Oscillator, PIC16LF1764/5/8/9 Only.

# PIC16(L)F1764/5/8/9

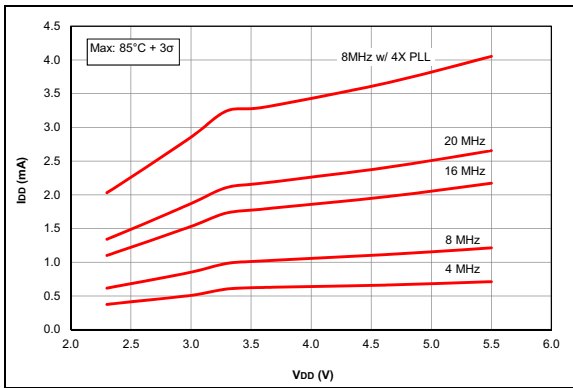
**Note:** Unless otherwise noted,  $V_{IN} = 5V$ ,  $F_{OSC} = 300\text{ kHz}$ ,  $C_{IN} = 0.1\ \mu\text{F}$ ,  $T_A = 25^\circ\text{C}$ .



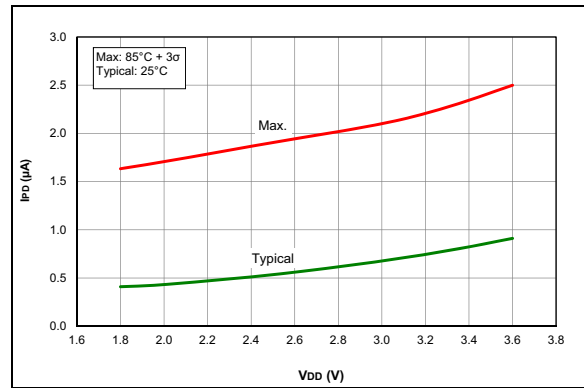
**FIGURE 37-25:**  $I_{DD}$  Typical, HS Oscillator,  $25^\circ\text{C}$ , PIC16F1764/5/8/9 Only.



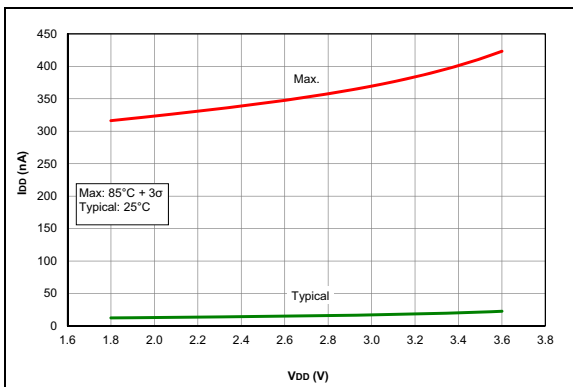
**FIGURE 37-28:**  $I_{PD}$  Base, LP Sleep Mode ( $V_{REGPM} = 1$ ), PIC16F1764/5/8/9 Only.



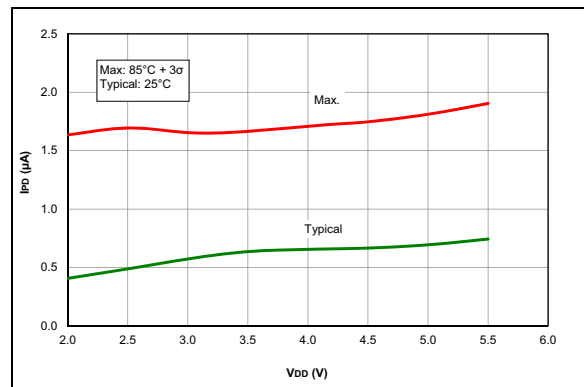
**FIGURE 37-26:**  $I_{DD}$  Maximum, HS Oscillator, PIC16F1764/5/8/9 Only.



**FIGURE 37-29:**  $I_{PD}$ , Watchdog Timer (WDT), PIC16LF1764/5/8/9 Only.



**FIGURE 37-27:**  $I_{PD}$  Base, LP Sleep Mode, PIC16LF1764/5/8/9 Only.

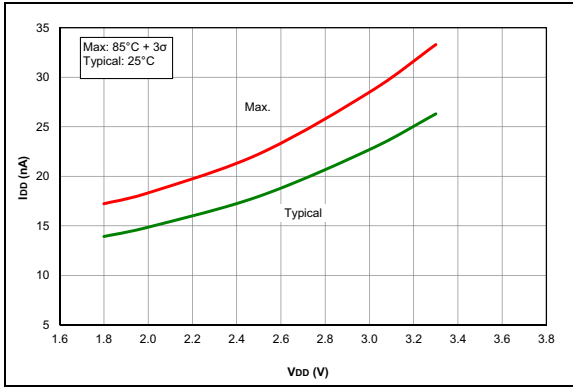


**FIGURE 37-30:**  $I_{PD}$ , Watchdog Timer (WDT), PIC16F1764/5/8/9 Only.

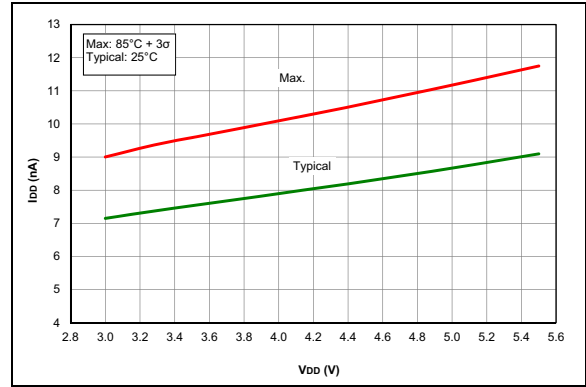


# PIC16(L)F1764/5/8/9

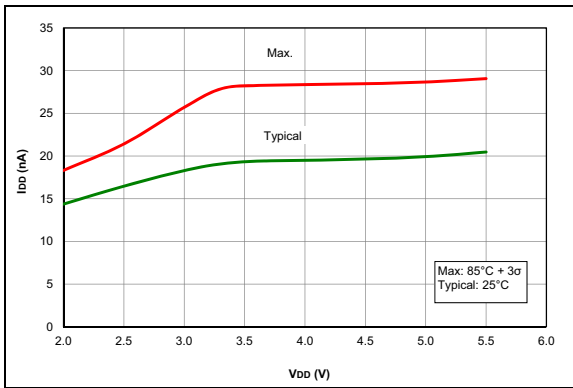
**Note:** Unless otherwise noted,  $V_{IN} = 5V$ ,  $F_{OSC} = 300\text{ kHz}$ ,  $C_{IN} = 0.1\ \mu\text{F}$ ,  $T_A = 25^\circ\text{C}$ .



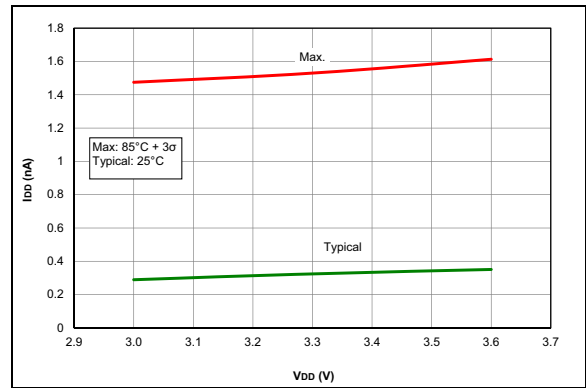
**FIGURE 37-31:**  $I_{DD}$ , Fixed Voltage Reference (FVR), PIC16LF1764/5/8/9 Only.



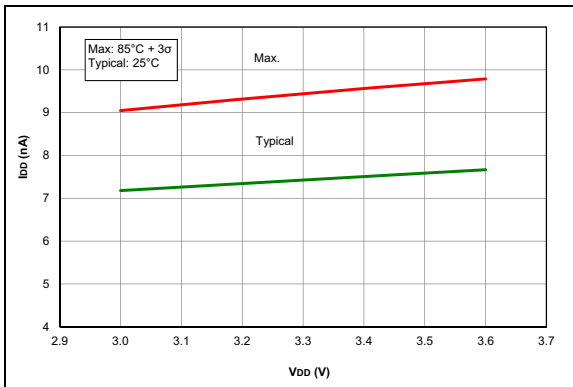
**FIGURE 37-34:**  $I_{DD}$ , Brown-Out Reset (BOR),  $BORV = 1$ , PIC16F1764/5/8/9 Only.



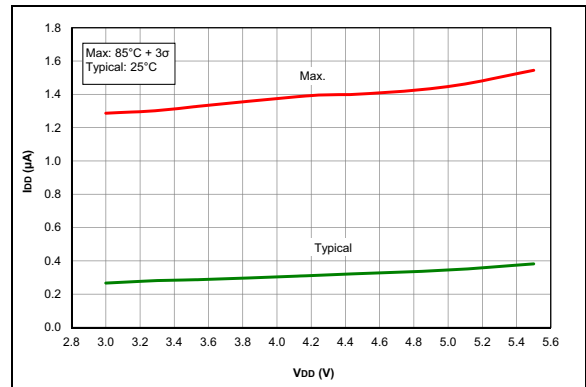
**FIGURE 37-32:**  $I_{DD}$ , Fixed Voltage Reference (FVR), PIC16F1764/5/8/9 Only.



**FIGURE 37-35:**  $I_{DD}$ , LP Brown-Out Reset ( $LPBOR = 0$ ), PIC16LF1764/5/8/9 Only.



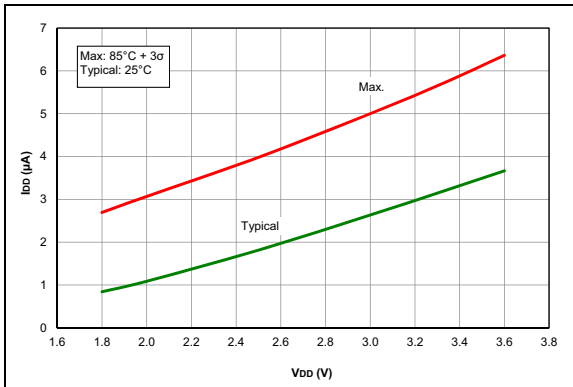
**FIGURE 37-33:**  $I_{DD}$ , Brown-Out Reset (BOR),  $BORV = 1$ , PIC16LF1764/5/8/9 Only.



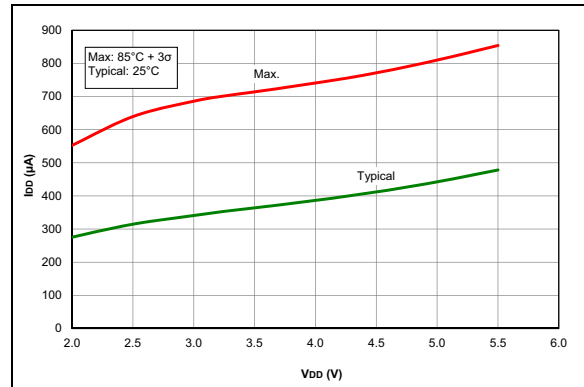
**FIGURE 37-36:**  $I_{DD}$ , LP Brown-Out Reset ( $LPBOR = 0$ ), PIC16F1764/5/8/9 Only.

# PIC16(L)F1764/5/8/9

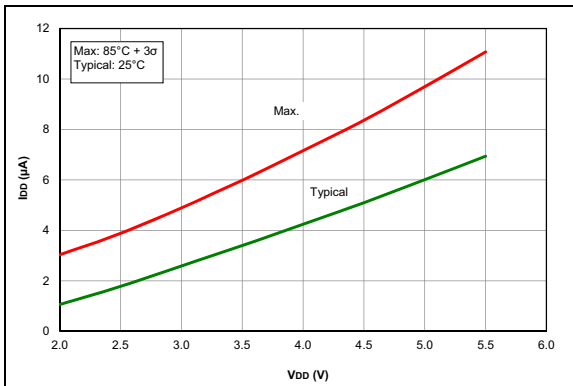
**Note:** Unless otherwise noted,  $V_{IN} = 5V$ ,  $F_{OSC} = 300\text{ kHz}$ ,  $C_{IN} = 0.1\ \mu\text{F}$ ,  $T_A = 25^\circ\text{C}$ .



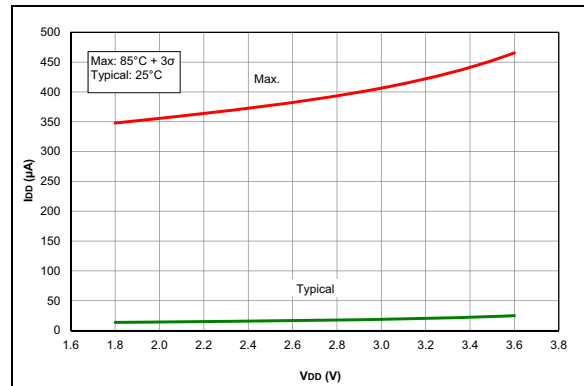
**FIGURE 37-37:**  $I_{DD}$ , Timer1 Oscillator,  $F_{OSC} = 32\text{ kHz}$ , PIC16LF1764/5/8/9 Only.



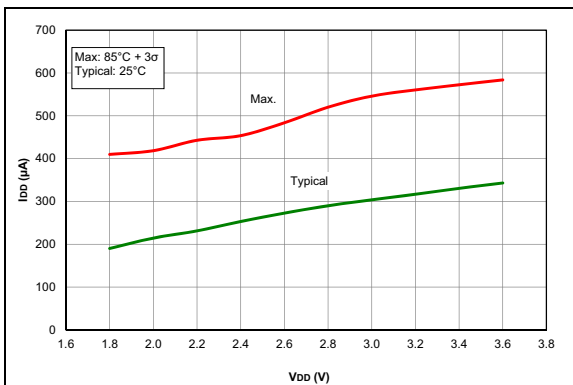
**FIGURE 37-40:**  $I_{DD}$ , Op Amp, High GBWP Mode ( $OPAxSP = 1$ ), PIC16F1764/5/8/9 Only.



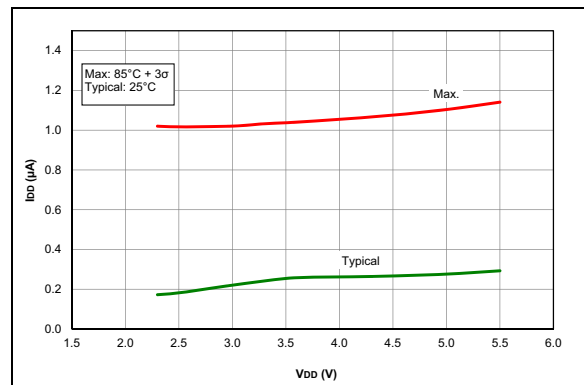
**FIGURE 37-38:**  $I_{DD}$ , Timer1 Oscillator,  $F_{OSC} = 32\text{ kHz}$ , PIC16F1764/5/8/9 Only.



**FIGURE 37-41:**  $I_{DD}$ , ADC Non-Converting, PIC16LF1764/5/8/9 Only.



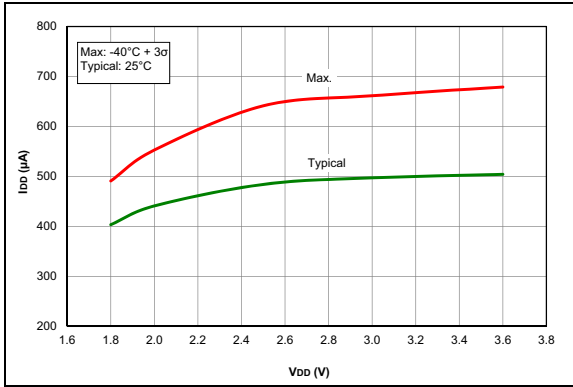
**FIGURE 37-39:**  $I_{DD}$ , Op Amp, High GBWP Mode ( $OPAxSP = 1$ ), PIC16LF1764/5/8/9 Only.



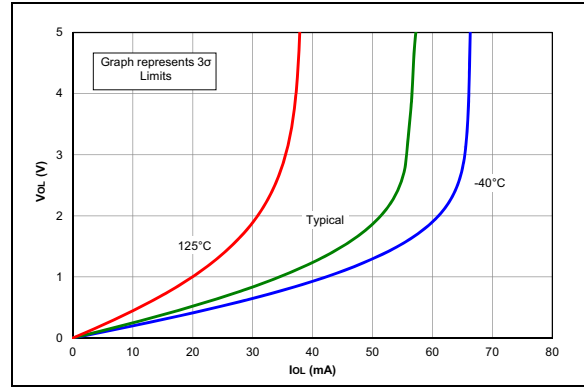
**FIGURE 37-42:**  $I_{DD}$ , ADC Non-Converting, PIC16F1764/5/8/9 Only.

# PIC16(L)F1764/5/8/9

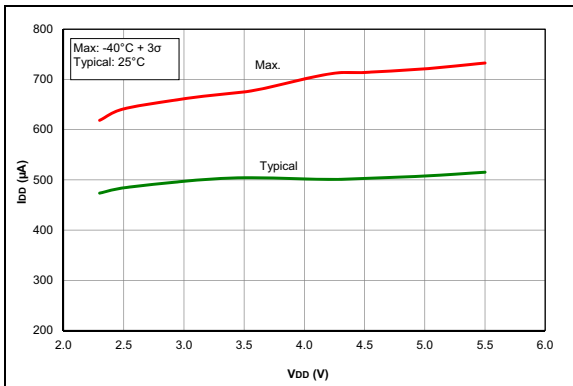
**Note:** Unless otherwise noted,  $V_{IN} = 5V$ ,  $F_{OSC} = 300\text{ kHz}$ ,  $C_{IN} = 0.1\ \mu\text{F}$ ,  $T_A = 25^\circ\text{C}$ .



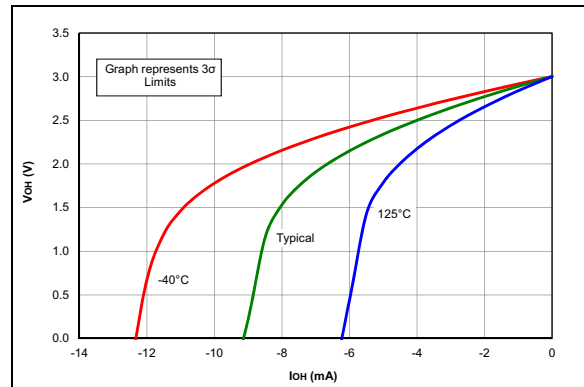
**FIGURE 37-43:**  $I_{PD}$ , Comparator, NP Mode ( $CxSP = 1$ ), PIC16LF1764/5/8/9 Only.



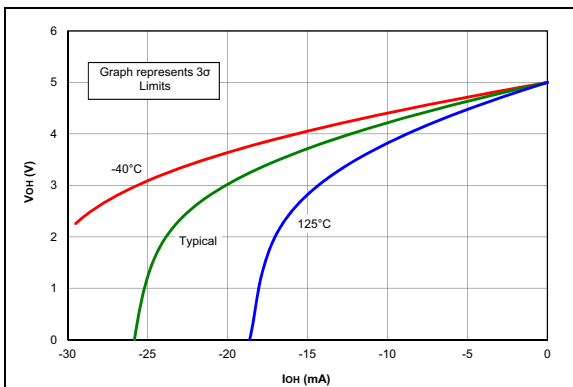
**FIGURE 37-46:** Standard IO  $V_{OL}$  vs.  $I_{OL}$  Over Temperature,  $V_{DD} = 5.0V$ , PIC16F1764/5/8/9 Only.



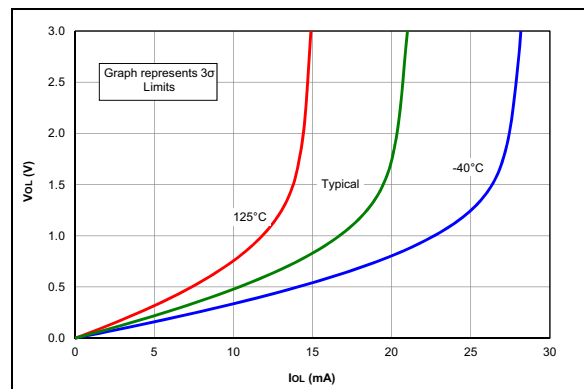
**FIGURE 37-44:**  $I_{PD}$ , Comparator, NP Mode ( $CxSP = 1$ ), PIC16F1764/5/8/9 Only.



**FIGURE 37-47:** Standard IO  $V_{OH}$  vs.  $I_{OH}$  Over Temperature,  $V_{DD} = 3.0V$ .



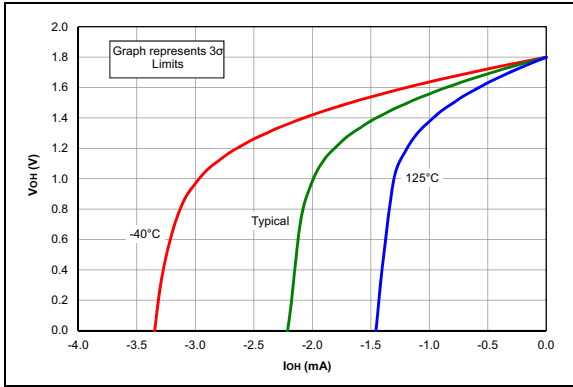
**FIGURE 37-45:** Standard IO  $V_{OH}$  vs.  $I_{OH}$  Over Temperature,  $V_{DD} = 5.0V$ , PIC16F1764/5/8/9 Only.



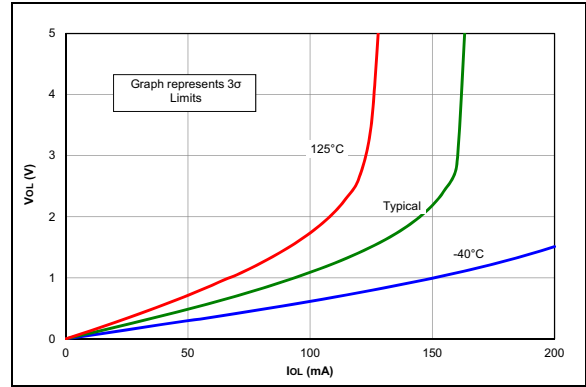
**FIGURE 37-48:** Standard IO  $V_{OL}$  vs.  $I_{OL}$  Over Temperature,  $V_{DD} = 3.0V$ .

# PIC16(L)F1764/5/8/9

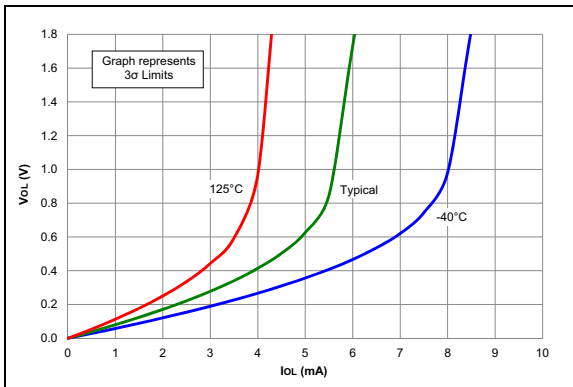
**Note:** Unless otherwise noted,  $V_{IN} = 5V$ ,  $F_{OSC} = 300\text{ kHz}$ ,  $C_{IN} = 0.1\ \mu\text{F}$ ,  $T_A = 25^\circ\text{C}$ .



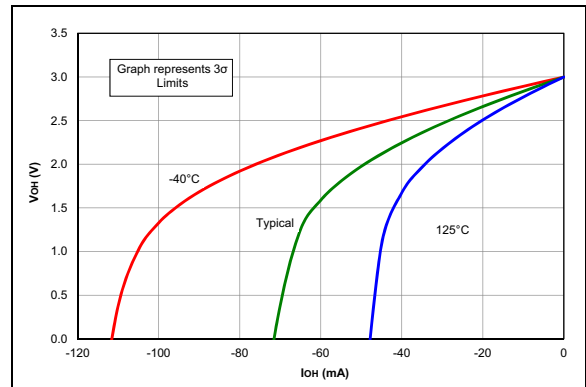
**FIGURE 37-49:** Standard IO  $V_{OH}$  vs.  $I_{OH}$  Over Temperature,  $V_{DD} = 1.8V$ , PIC16LF1764/5/8/9 Only.



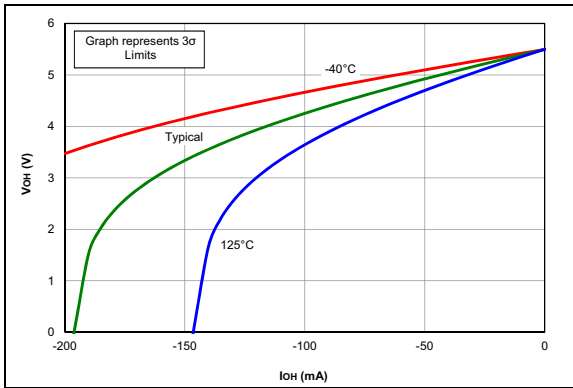
**FIGURE 37-52:** 100mA IO  $V_{OL}$  vs.  $I_{OL}$  Over Temperature,  $V_{DD} = 5.5V$ , PIC16F1764/5/8/9 Only.



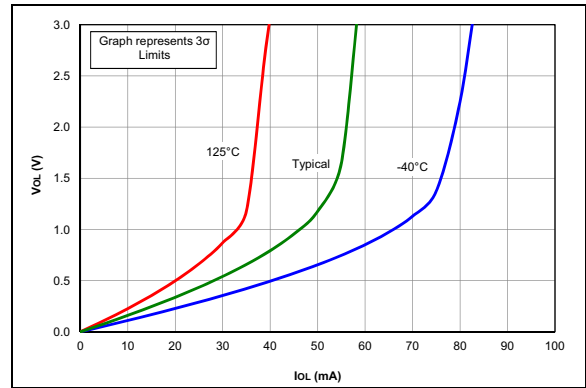
**FIGURE 37-50:** Standard IO  $V_{OL}$  vs.  $I_{OL}$  Over Temperature,  $V_{DD} = 1.8V$ , PIC16LF1764/5/8/9 Only.



**FIGURE 37-53:** 100mA IO  $V_{OH}$  vs.  $I_{OH}$  Over Temperature,  $V_{DD} = 3.0V$ .



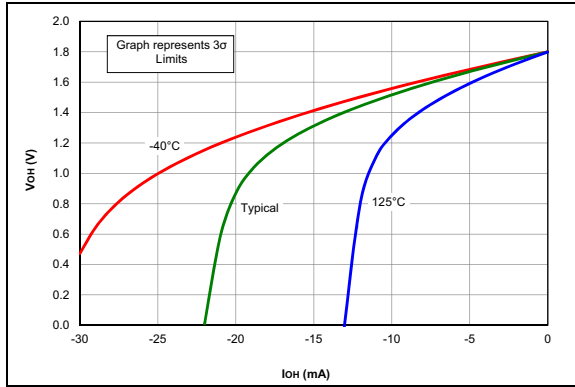
**FIGURE 37-51:** 100mA IO  $V_{OH}$  vs.  $I_{OH}$  Over Temperature,  $V_{DD} = 5.5V$ , PIC16F1764/5/8/9 Only.



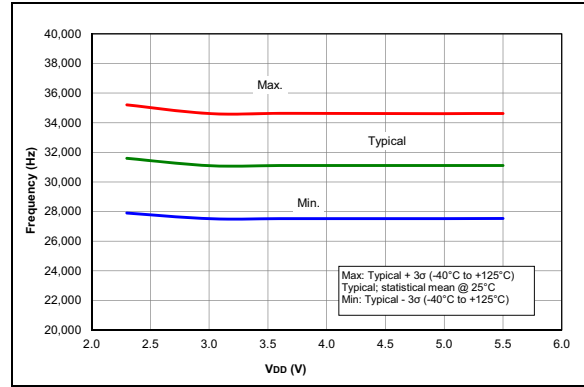
**FIGURE 37-54:**  $V_{OL}$  vs.  $I_{OL}$  Over Temperature,  $V_{DD} = 3.0V$ .

# PIC16(L)F1764/5/8/9

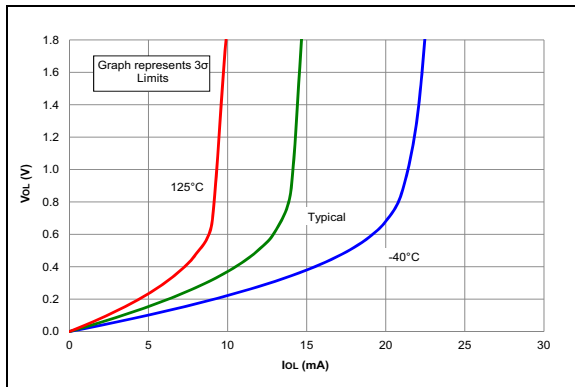
**Note:** Unless otherwise noted,  $V_{IN} = 5V$ ,  $F_{OSC} = 300\text{ kHz}$ ,  $C_{IN} = 0.1\ \mu\text{F}$ ,  $T_A = 25^\circ\text{C}$ .



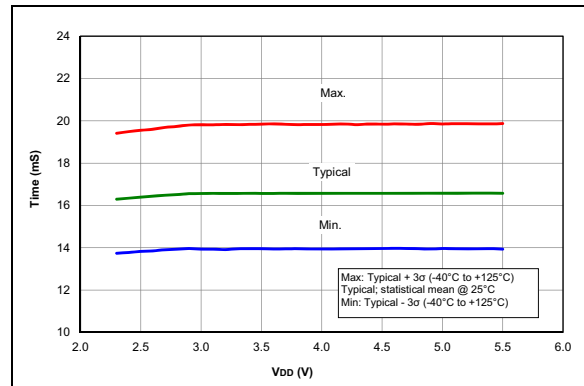
**FIGURE 37-55:** 100mA IO  $V_{OH}$  vs.  $I_{OH}$  Over Temperature,  $V_{DD} = 1.8V$ , PIC16LF1764/5/8/9 Only.



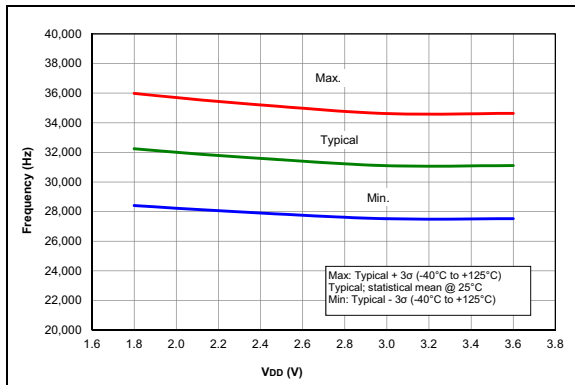
**FIGURE 37-58:** LFINTOSC Frequency, PIC16F1764/5/8/9 Only.



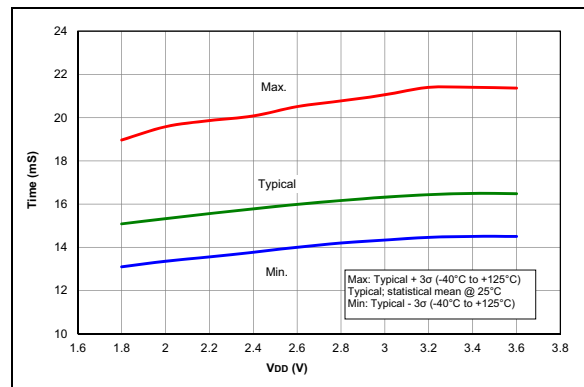
**FIGURE 37-56:** 100mA IO  $V_{OL}$  vs.  $I_{OL}$  Over Temperature,  $V_{DD} = 1.8V$ , PIC16LF1764/5/8/9 Only.



**FIGURE 37-59:** WDT Time-Out Period, PIC16F1764/5/8/9 Only.



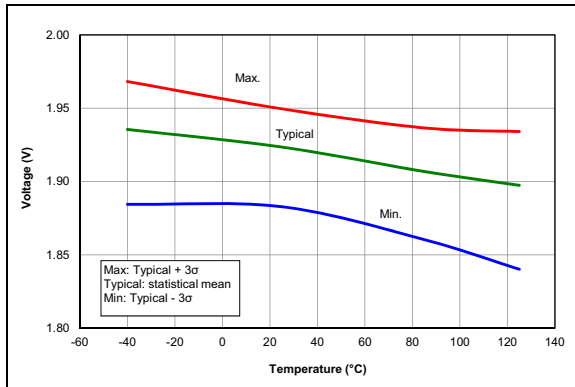
**FIGURE 37-57:** LFINTOSC Frequency, PIC16LF1764/5/8/9 Only.



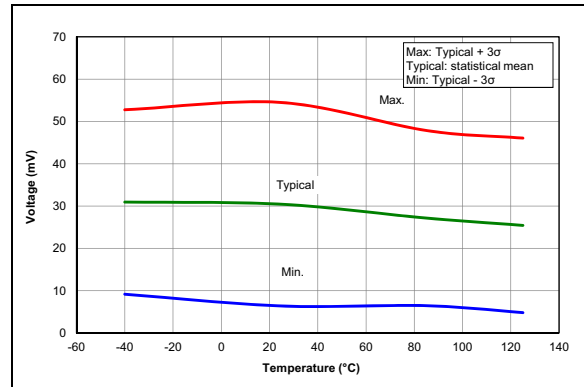
**FIGURE 37-60:** WDT Time-Out Period, PIC16LF1764/5/8/9 Only.

# PIC16(L)F1764/5/8/9

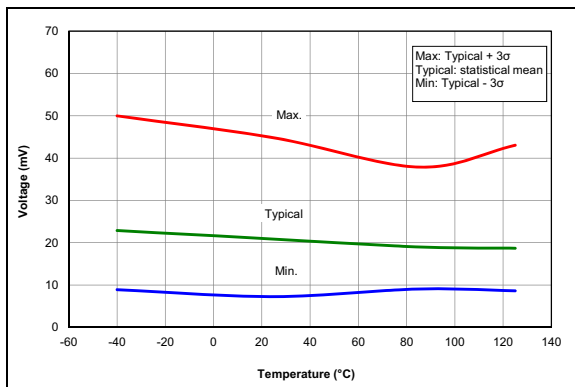
**Note:** Unless otherwise noted,  $V_{IN} = 5V$ ,  $F_{OSC} = 300\text{ kHz}$ ,  $C_{IN} = 0.1\ \mu\text{F}$ ,  $T_A = 25^\circ\text{C}$ .



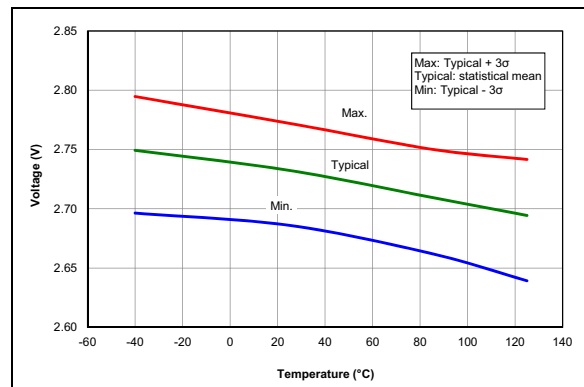
**FIGURE 37-61:** Brown-Out Reset Voltage, Low Trip Point ( $BORV = 1$ ), PIC16LF1764/5/8/9 Only.



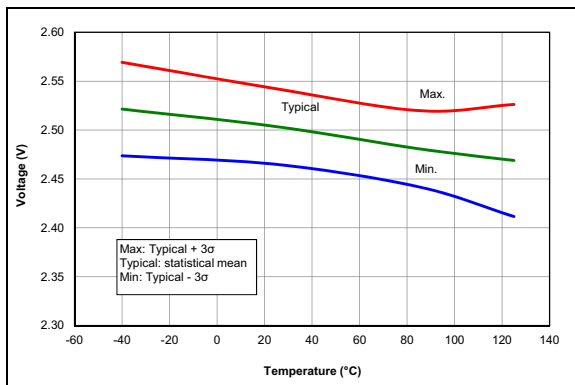
**FIGURE 37-64:** Brown-Out Reset Hysteresis, Low Trip Point ( $BORV = 1$ ), PIC16F1764/5/8/9 Only.



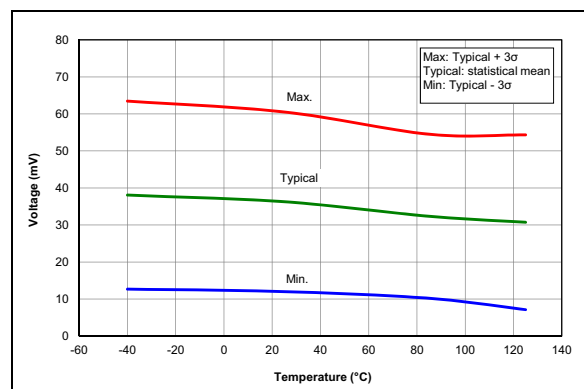
**FIGURE 37-62:** Brown-Out Reset Hysteresis, Low Trip Point ( $BORV = 1$ ), PIC16LF1764/5/8/9 Only.



**FIGURE 37-65:** Brown-Out Reset Voltage, High Trip Point ( $BORV = 0$ ).



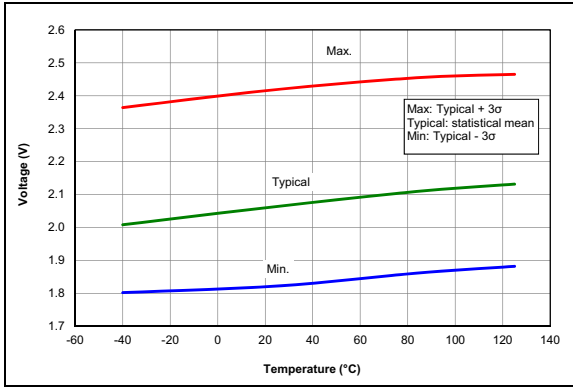
**FIGURE 37-63:** Brown-Out Reset Voltage, Low Trip Point ( $BORV = 1$ ), PIC16F1764/5/8/9 Only.



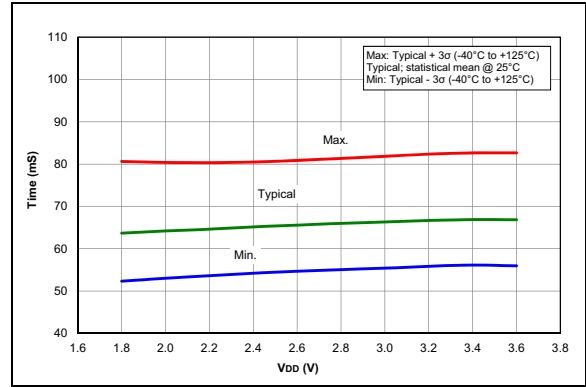
**FIGURE 37-66:** Brown-Out Reset Hysteresis, High Trip Point ( $BORV = 0$ ).

# PIC16(L)F1764/5/8/9

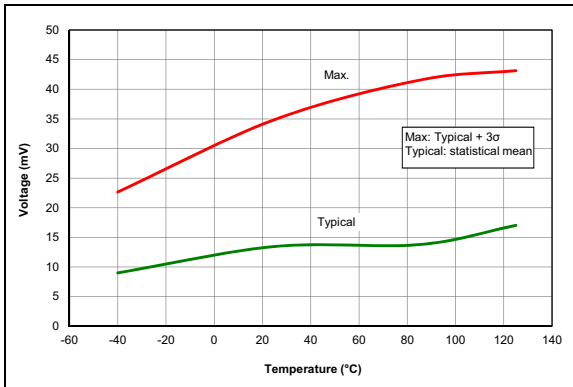
**Note:** Unless otherwise noted,  $V_{IN} = 5V$ ,  $F_{OSC} = 300\text{ kHz}$ ,  $C_{IN} = 0.1\ \mu\text{F}$ ,  $T_A = 25^\circ\text{C}$ .



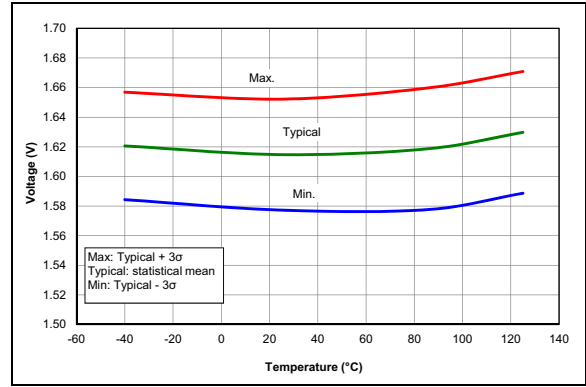
**FIGURE 37-67:** LPBOR Reset Voltage.



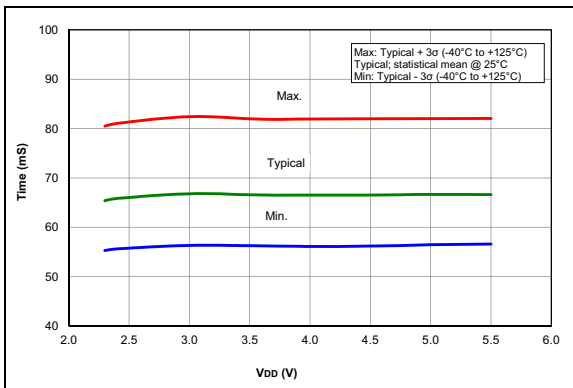
**FIGURE 37-70:** PWRT Period, PIC16LF1764/5/8/9 Only.



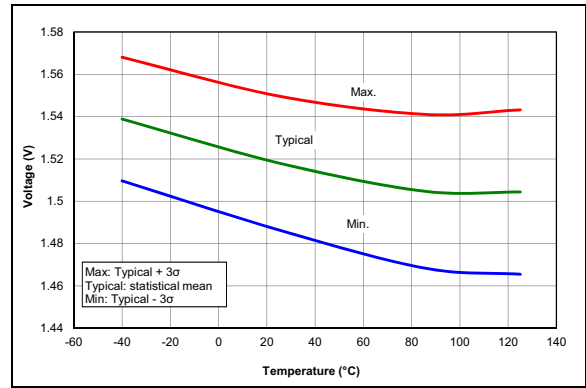
**FIGURE 37-68:** LPBOR Reset Hysteresis.



**FIGURE 37-71:** POR Release Voltage.



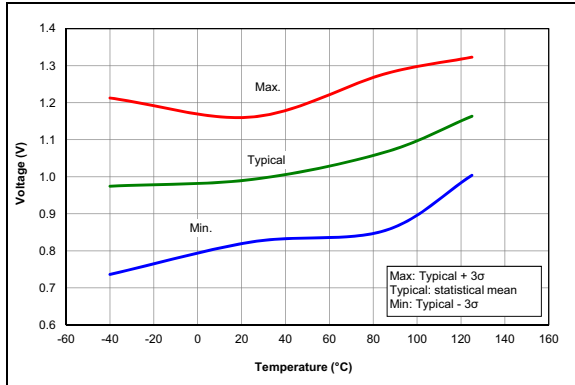
**FIGURE 37-69:** PWRT Period, PIC16F1764/5/8/9 Only.



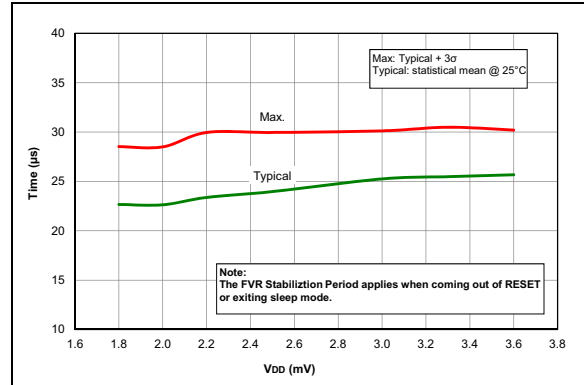
**FIGURE 37-72:** POR Rearm Voltage, NP Mode ( $V_{REGPM} = 0$ ), PIC16F1764/5/8/9 Only.

# PIC16(L)F1764/5/8/9

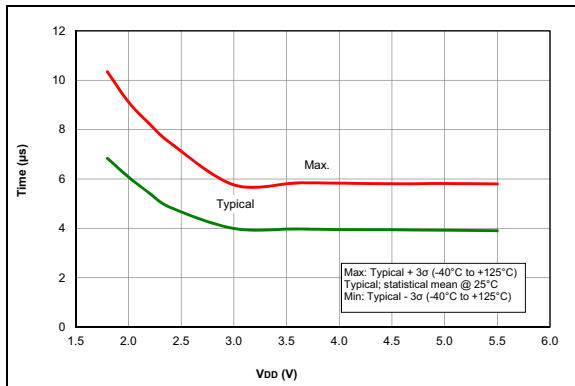
**Note:** Unless otherwise noted,  $V_{IN} = 5V$ ,  $F_{OSC} = 300\text{ kHz}$ ,  $C_{IN} = 0.1\ \mu\text{F}$ ,  $T_A = 25^\circ\text{C}$ .



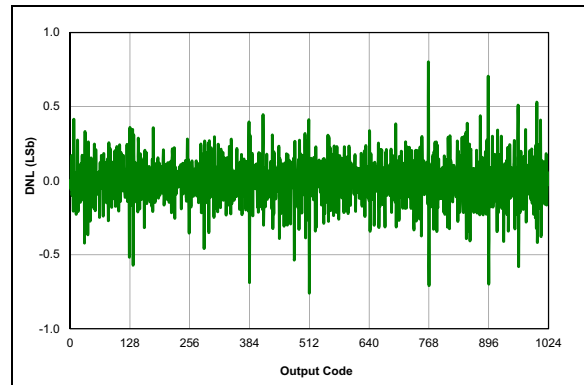
**FIGURE 37-73:** POR Rearm Voltage, NP Mode, PIC16LF1764/5/8/9 Only.



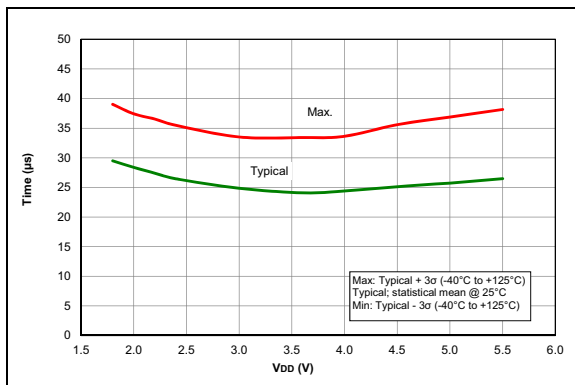
**FIGURE 37-76:** FVR Stabilization Period, PIC16LF1764/5/8/9 Only.



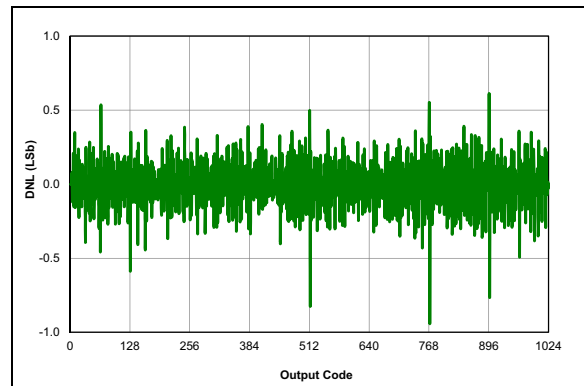
**FIGURE 37-74:** Wake From Sleep,  $V_{REGPM} = 0$ .



**FIGURE 37-77:** ADC 10-Bit Mode, Single-Ended DNL,  $V_{DD} = 3.0V$ ,  $T_{AD} = 1\ \mu\text{S}$ ,  $25^\circ\text{C}$ .



**FIGURE 37-75:** Wake From Sleep,  $V_{REGPM} = 1$ .

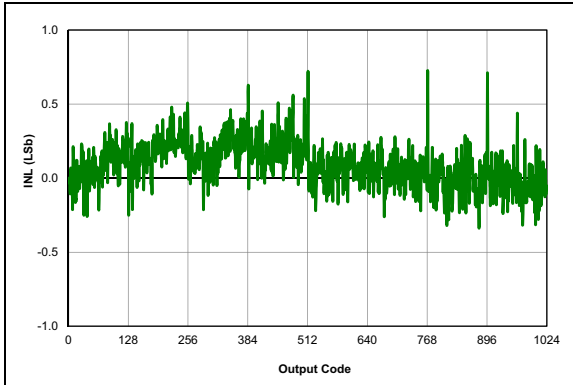


**FIGURE 37-78:** ADC 10-Bit Mode, Single-Ended DNL,  $V_{DD} = 3.0V$ ,  $T_{AD} = 4\ \mu\text{S}$ ,  $25^\circ\text{C}$ .

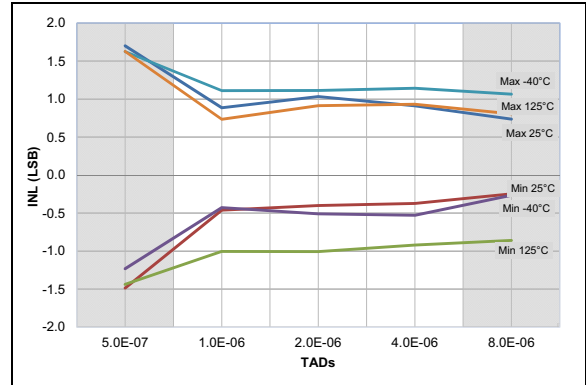


# PIC16(L)F1764/5/8/9

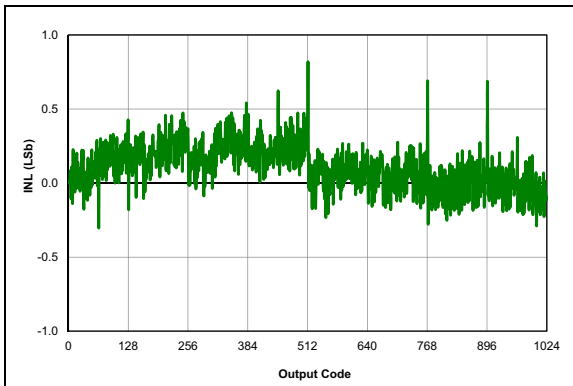
**Note:** Unless otherwise noted,  $V_{IN} = 5V$ ,  $F_{OSC} = 300\text{ kHz}$ ,  $C_{IN} = 0.1\ \mu\text{F}$ ,  $T_A = 25^\circ\text{C}$ .



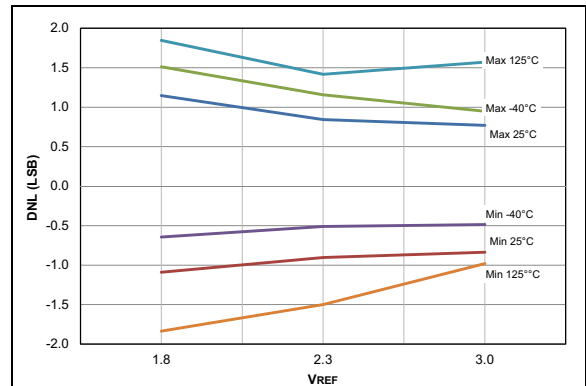
**FIGURE 37-79:** ADC 10-Bit Mode, Single-Ended INL,  $V_{DD} = 3.0V$ ,  $T_{AD} = 1\ \mu\text{s}$ ,  $25^\circ\text{C}$ .



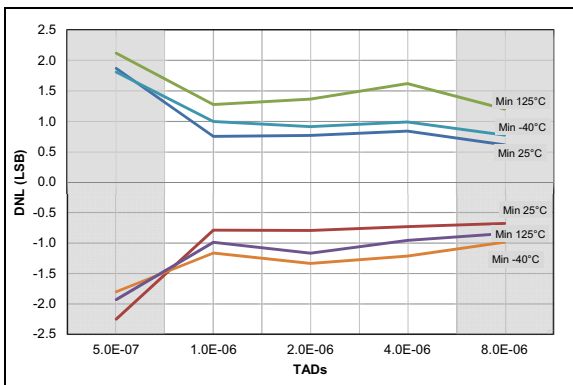
**FIGURE 37-82:** ADC 10-Bit Mode, Single-Ended INL,  $V_{DD} = 3.0V$ ,  $V_{REF} = 3.0V$ .



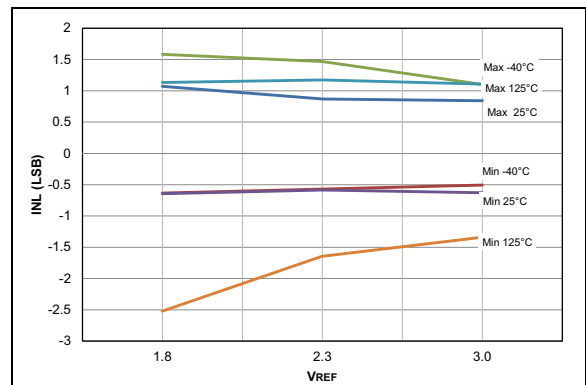
**FIGURE 37-80:** ADC 10-Bit Mode, Single-Ended INL,  $V_{DD} = 3.0V$ ,  $T_{AD} = 4\ \mu\text{s}$ ,  $25^\circ\text{C}$ .



**FIGURE 37-83:** ADC 10-Bit Mode, Single-Ended DNL,  $V_{DD} = 3.0V$ ,  $T_{AD} = 1\ \mu\text{s}$ .

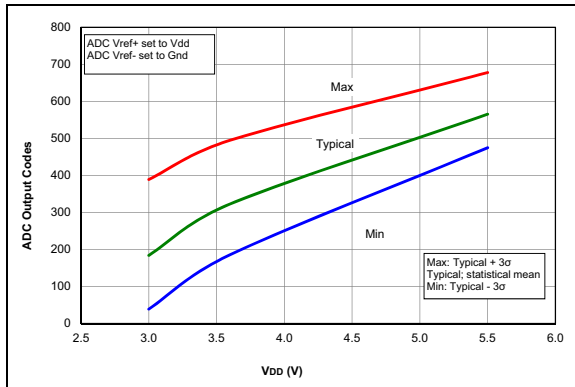


**FIGURE 37-81:** ADC 10-Bit Mode, Single-Ended DNL,  $V_{DD} = 3.0V$ ,  $V_{REF} = 3.0V$ .

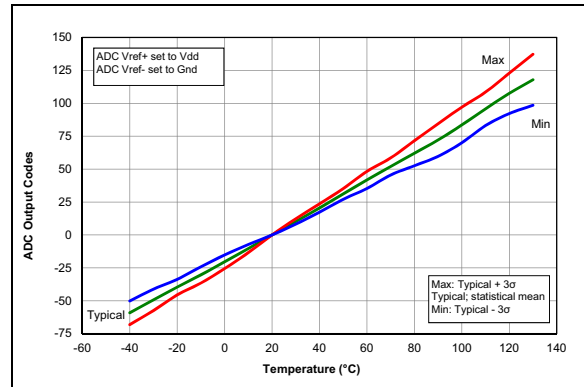


**FIGURE 37-84:** ADC 10-Bit Mode, Single-Ended INL,  $V_{DD} = 3.0V$ ,  $T_{AD} = 1\ \mu\text{s}$ .

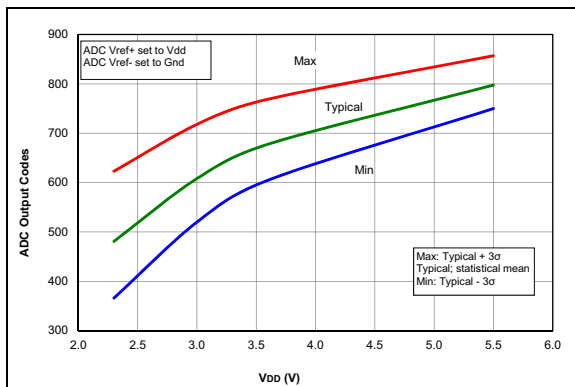
**Note:** Unless otherwise noted,  $V_{IN} = 5V$ ,  $F_{OSC} = 300\text{ kHz}$ ,  $C_{IN} = 0.1\ \mu\text{F}$ ,  $T_A = 25^\circ\text{C}$ .



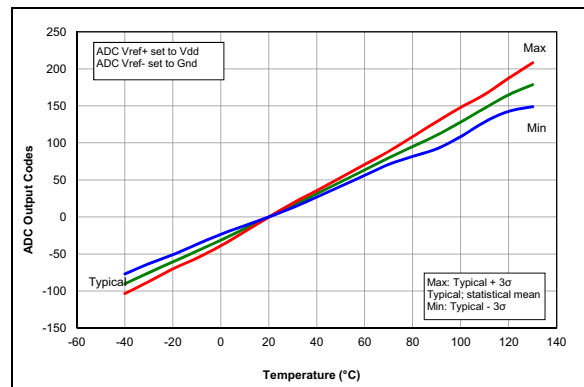
**FIGURE 37-85:** Temp. Indicator Initial Offset, High Range, Temp. = 20°C, PIC16F1764/5/8/9 Only.



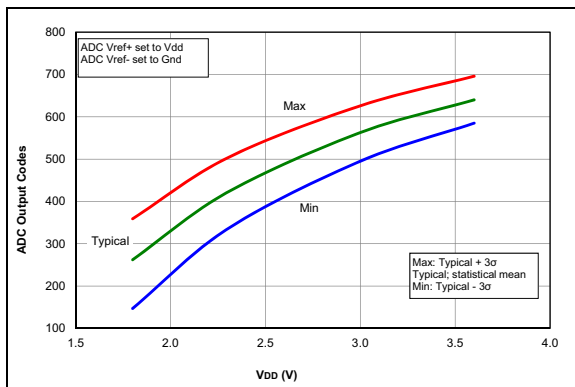
**FIGURE 37-88:** Temp. Indicator Slope Normalized to 20°C, High Range,  $V_{DD} = 5.5V$ , PIC16F1764/5/8/9 Only.



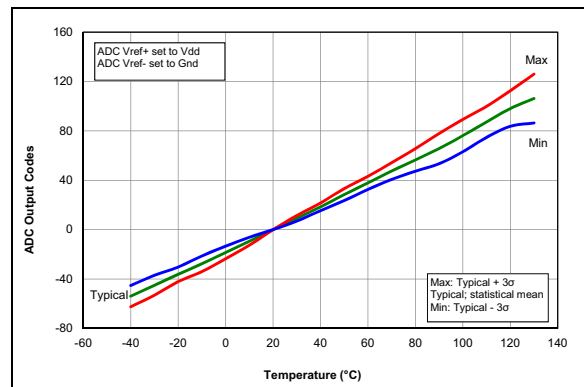
**FIGURE 37-86:** Temp. Indicator Initial Offset, Low Range, Temp. = 20°C, PIC16F1764/5/8/9 Only.



**FIGURE 37-89:** Temp. Indicator Slope Normalized to 20°C, High Range,  $V_{DD} = 3.6V$ , PIC16F1764/5/8/9 Only.



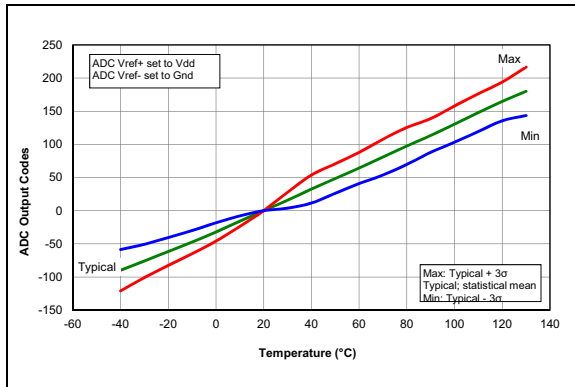
**FIGURE 37-87:** Temp. Indicator Initial Offset, Low Range, Temp. = 20°C, PIC16LF1764/5/8/9 Only.



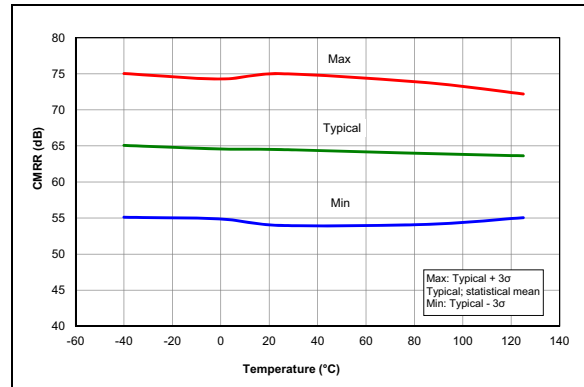
**FIGURE 37-90:** Temp. Indicator Slope Normalized to 20°C, Low Range,  $V_{DD} = 3.0V$ , PIC16F1764/5/8/9 Only.

# PIC16(L)F1764/5/8/9

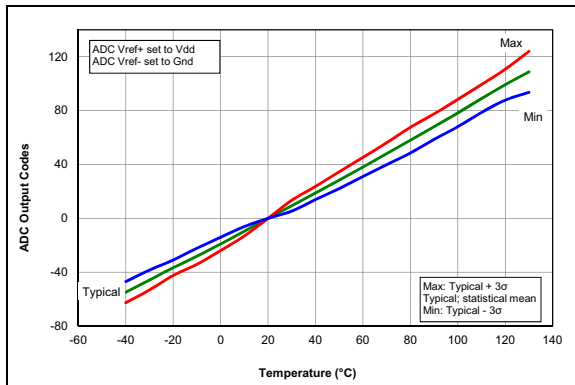
**Note:** Unless otherwise noted,  $V_{IN} = 5V$ ,  $F_{OSC} = 300\text{ kHz}$ ,  $C_{IN} = 0.1\ \mu\text{F}$ ,  $T_A = 25^\circ\text{C}$ .



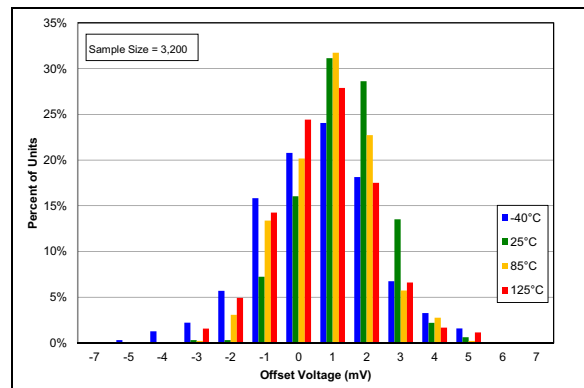
**FIGURE 37-91:** Temp. Indicator Slope Normalized to  $20^\circ\text{C}$ , Low Range,  $V_{DD} = 1.8V$ , PIC16LF1764/5/8/9 Only.



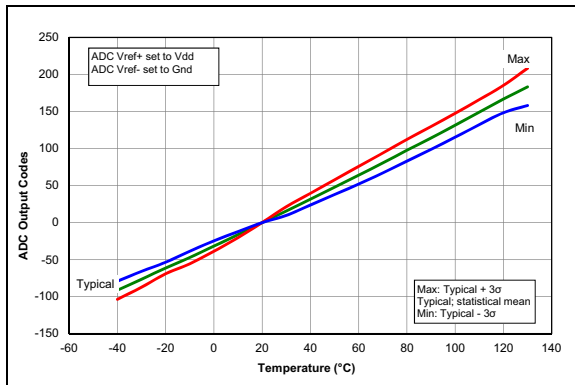
**FIGURE 37-94:** Op Amp, Common Mode Rejection Ratio (CMRR),  $V_{DD} = 3.0V$ .



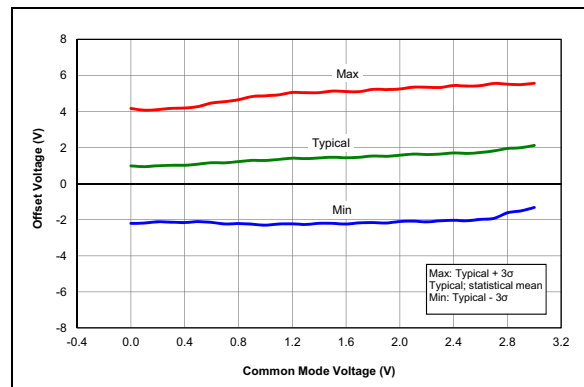
**FIGURE 37-92:** Temp. Indicator Slope Normalized to  $20^\circ\text{C}$ , Low Range,  $V_{DD} = 3.0V$ , PIC16LF1764/5/8/9 Only.



**FIGURE 37-95:** Op Amp, Output Voltage Histogram,  $V_{DD} = 3.0V$ ,  $V_{CM} = V_{DD}/2$ .



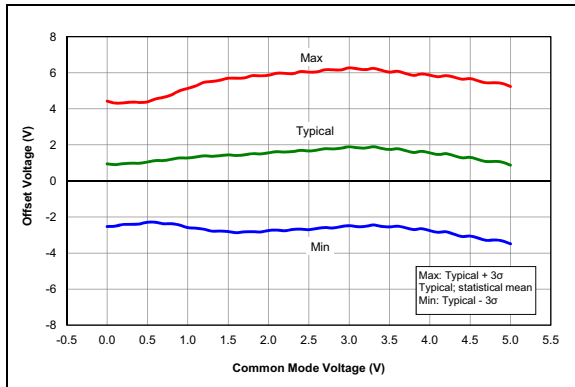
**FIGURE 37-93:** Temp. Indicator Slope Normalized to  $20^\circ\text{C}$ , High Range,  $V_{DD} = 3.6V$ , PIC16LF1764/5/8/9 Only.



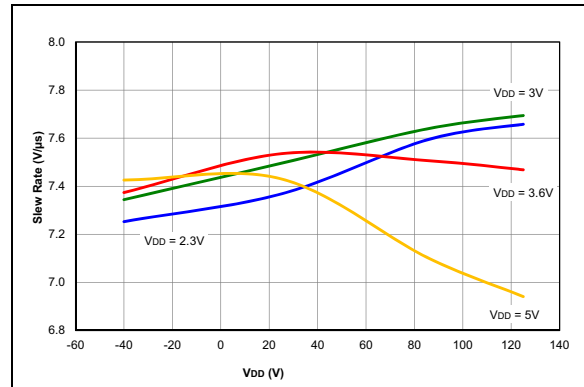
**FIGURE 37-96:** Op Amp, Offset Over Common Mode Voltage,  $V_{DD} = 3.0V$ , Temp. =  $25^\circ\text{C}$ .

# PIC16(L)F1764/5/8/9

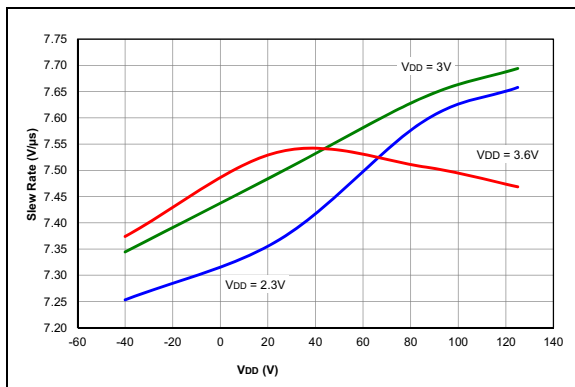
**Note:** Unless otherwise noted,  $V_{IN} = 5V$ ,  $F_{OSC} = 300\text{ kHz}$ ,  $C_{IN} = 0.1\ \mu\text{F}$ ,  $T_A = 25^\circ\text{C}$ .



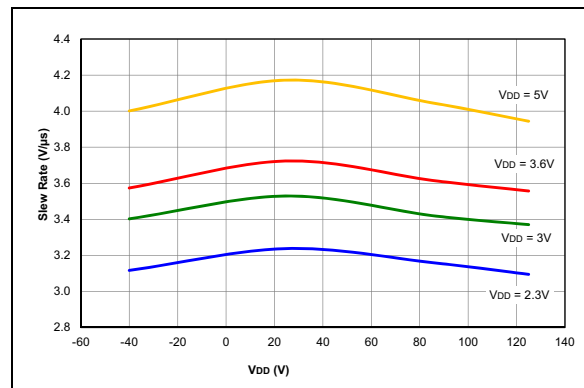
**FIGURE 37-97:** Op Amp, Offset Over Common Mode Voltage,  $V_{DD} = 5.0V$ , Temp. =  $25^\circ\text{C}$ , PIC16F1764/5/8/9 Only.



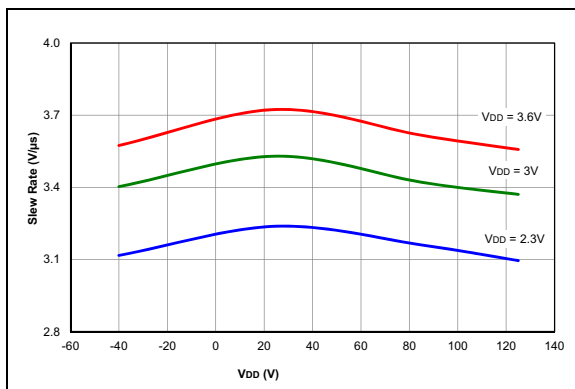
**FIGURE 37-100:** Op Amp, Output Slew Rate, Rising Edge, PIC16F1764/5/8/9 Only.



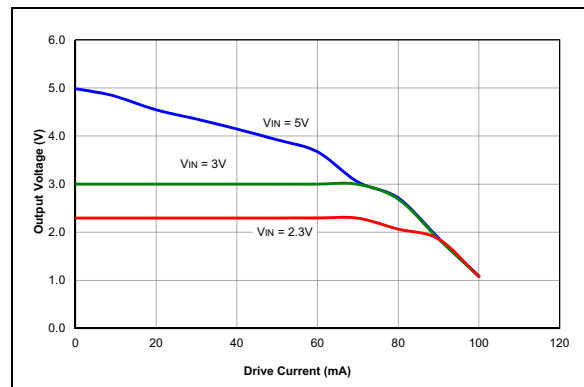
**FIGURE 37-98:** Op Amp, Output Slew Rate, Rising Edge, PIC16LF1764/5/8/9 Only.



**FIGURE 37-101:** Op Amp, Output Slew Rate, Falling Edge.

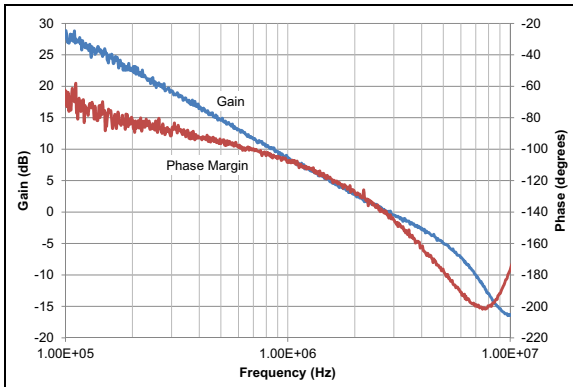


**FIGURE 37-99:** Op Amp, Output Slew Rate, Falling Edge, PIC16LF1764/5/8/9 Only.

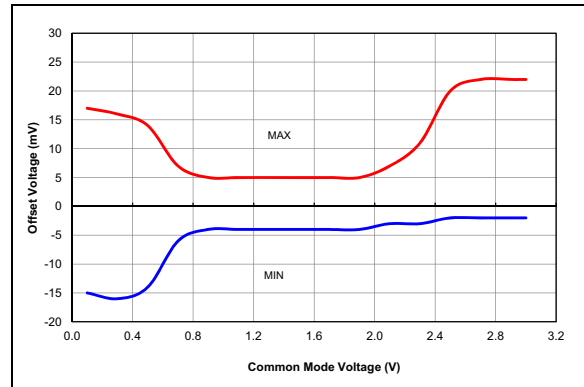


**FIGURE 37-102:** Op Amp, Output Drive Strength,  $V_{DD} = 5.0V$ , Temp. =  $25^\circ\text{C}$ , PIC16F1764/5/8/9 Only.

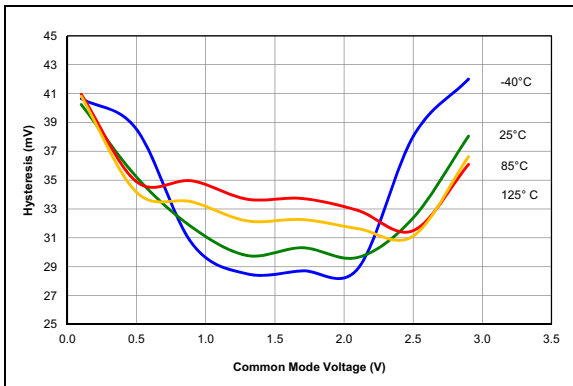
**Note:** Unless otherwise noted,  $V_{IN} = 5V$ ,  $F_{OSC} = 300\text{ kHz}$ ,  $C_{IN} = 0.1\ \mu\text{F}$ ,  $T_A = 25^\circ\text{C}$ .



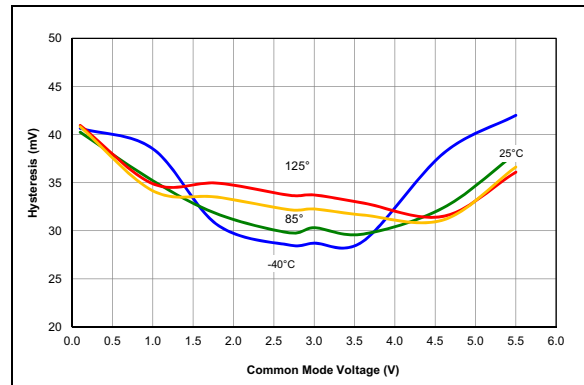
**FIGURE 37-103:** Typical Open Loop Gain, Phase Vs. Frequency, PIC16F1764/5/8/9 Only.



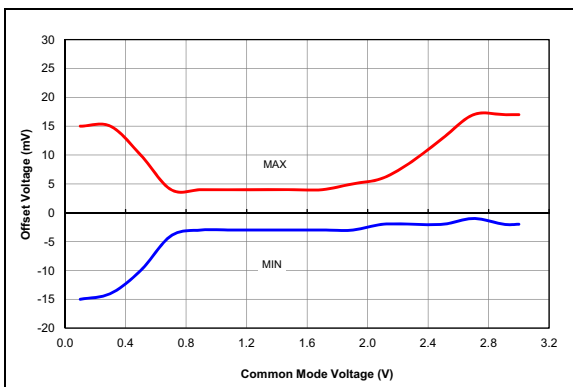
**FIGURE 37-106:** Comparator Offset, NP Mode ( $CxSP = 1$ ),  $V_{DD} = 3.0V$ , Typical Measured Values From  $-40^\circ\text{C}$  to  $125^\circ\text{C}$ .



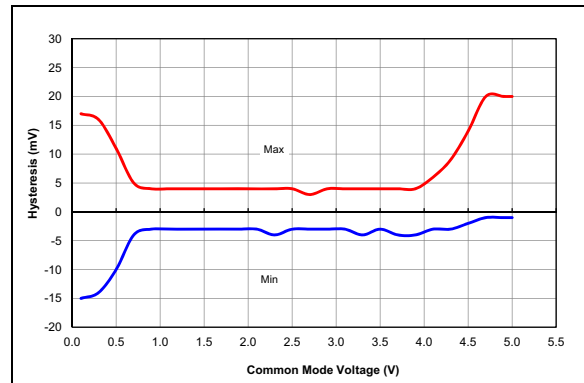
**FIGURE 37-104:** Comparator Hysteresis, NP Mode ( $CxSP = 1$ ),  $V_{DD} = 3.0V$ , Typical Measured Values.



**FIGURE 37-107:** Comparator Hysteresis, NP Mode ( $CxSP = 1$ ),  $V_{DD} = 5.5V$ , Typical Measured Values, PIC16F1764/5/8/9 Only.

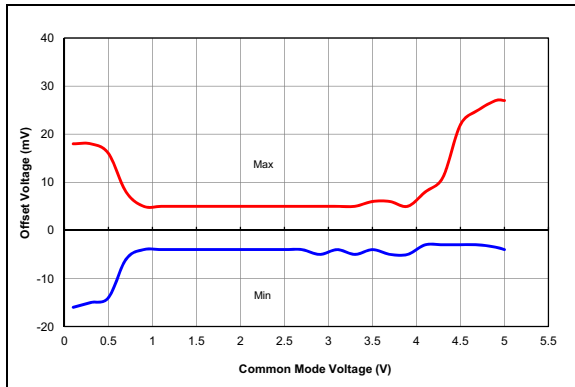


**FIGURE 37-105:** Comparator Offset, NP Mode ( $CxSP = 1$ ),  $V_{DD} = 3.0V$ , Typical Measured Values at  $25^\circ\text{C}$ .

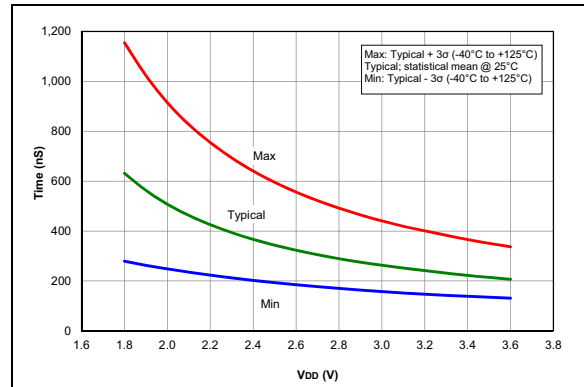


**FIGURE 37-108:** Comparator Offset, NP Mode ( $CxSP = 1$ ),  $V_{DD} = 5.0V$ , Typical Measured Values at  $25^\circ\text{C}$ , PIC16F1764/5/8/9 Only.

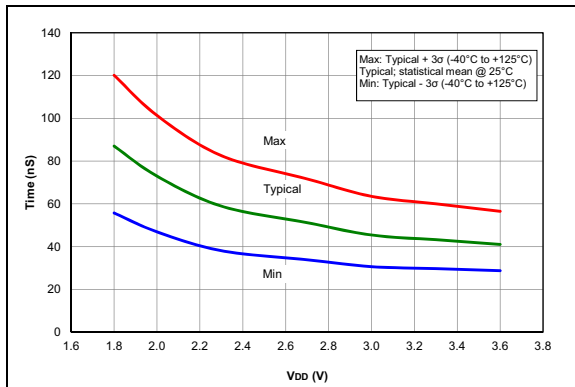
**Note:** Unless otherwise noted,  $V_{IN} = 5V$ ,  $F_{OSC} = 300\text{ kHz}$ ,  $C_{IN} = 0.1\ \mu\text{F}$ ,  $T_A = 25^\circ\text{C}$ .



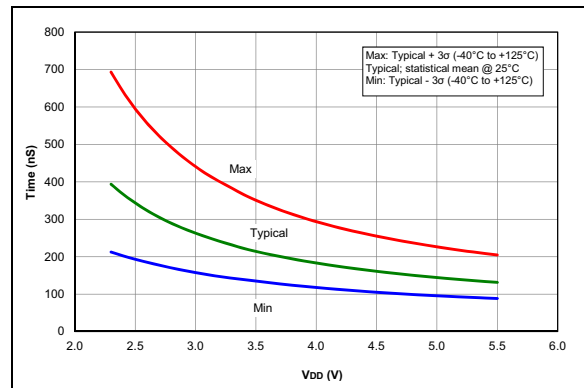
**FIGURE 37-109:** Comparator Offset, NP Mode ( $CxSP = 1$ ),  $V_{DD} = 5.5V$ , Typical Measured Values from  $-40^\circ\text{C}$  to  $125^\circ\text{C}$ , PIC16F1764/5/8/9 Only.



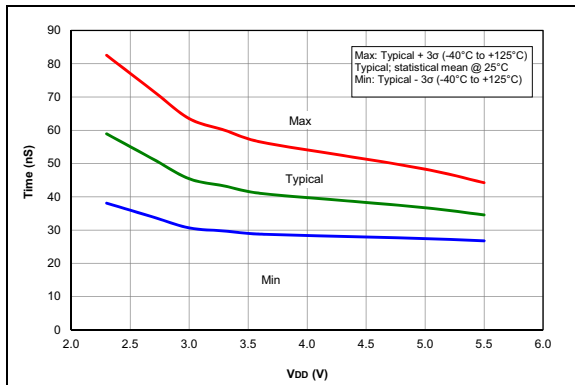
**FIGURE 37-112:** Comparator Output Filter Delay Time Over Temp., NP Mode ( $CxSP = 1$ ), Typical Measured Values, PIC16LF1764/5/8/9 Only.



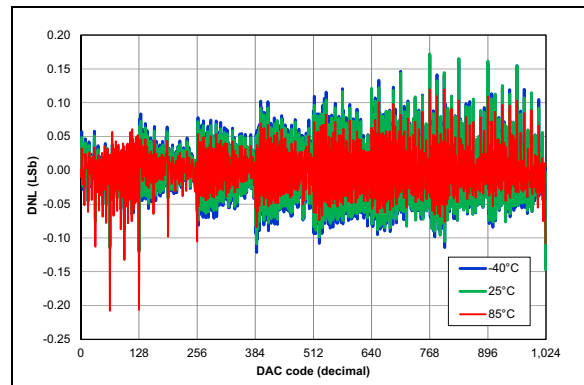
**FIGURE 37-110:** Comparator Response Time Over Voltage, NP Mode ( $CxSP = 1$ ), Typical Measured Values, PIC16LF1764/5/8/9 Only.



**FIGURE 37-113:** Comparator Output Filter Delay Time Over Temp., NP Mode ( $CxSP = 1$ ), Typical Measured Values, PIC16F1764/5/8/9 Only.



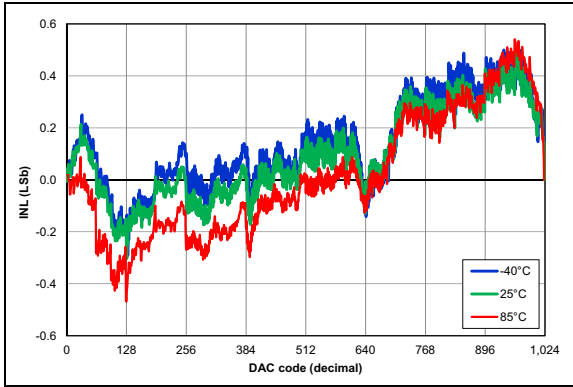
**FIGURE 37-111:** Comparator Response Time Over Voltage, NP Mode ( $CxSP = 1$ ), Typical Measured Values, PIC16F1764/5/8/9 Only.



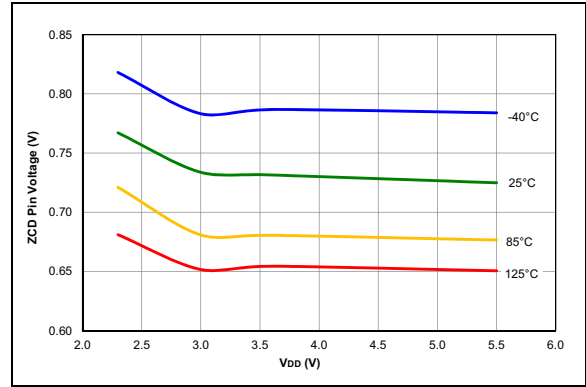
**FIGURE 37-114:** Typical DAC DNL Error,  $V_{DD} = 3.6V$ ,  $V_{REF} = V_{DD}$ .

# PIC16(L)F1764/5/8/9

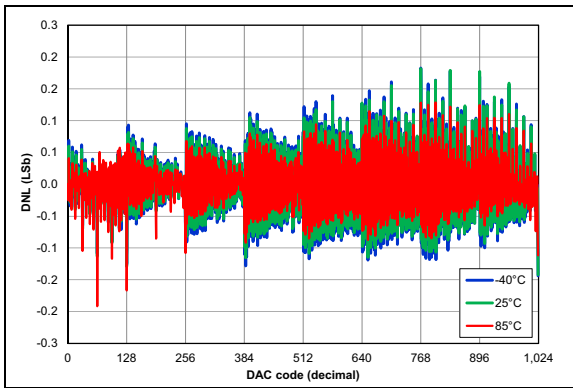
**Note:** Unless otherwise noted,  $V_{IN} = 5V$ ,  $F_{OSC} = 300\text{ kHz}$ ,  $C_{IN} = 0.1\ \mu\text{F}$ ,  $T_A = 25^\circ\text{C}$ .



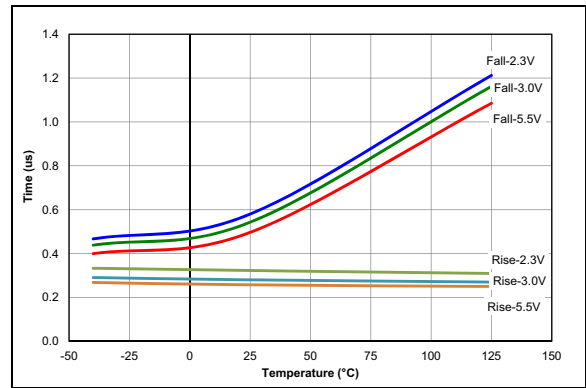
**FIGURE 37-115:** Typical INL Error,  $V_{DD} = 3.6V$ ,  $V_{REF} = V_{DD}$ .



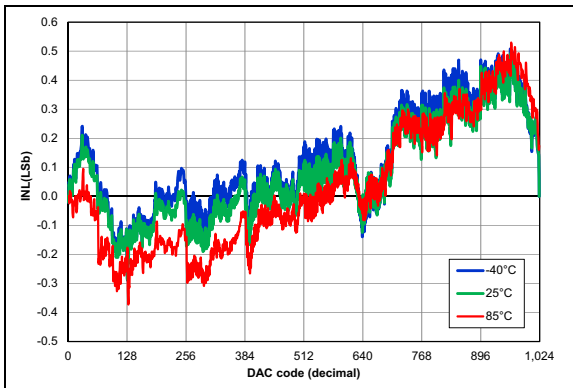
**FIGURE 37-118:** ZCD Pin voltage, Typical Measured Values.



**FIGURE 37-116:** Typical DAC DNL Error,  $V_{DD} = 5.0V$ ,  $V_{REF} = V_{DD}$ , PIC16F1764/5/8/9 Only.

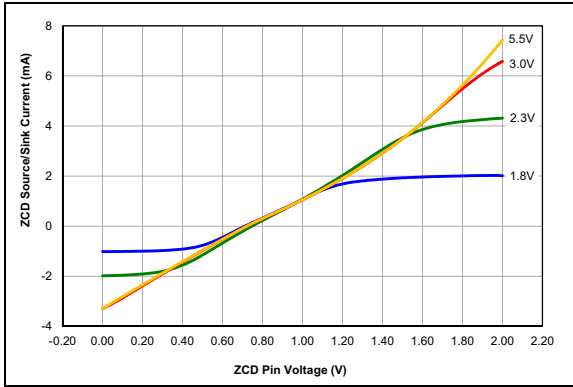


**FIGURE 37-119:** ZCD Response Time Over Voltage, Typical Measured Values.

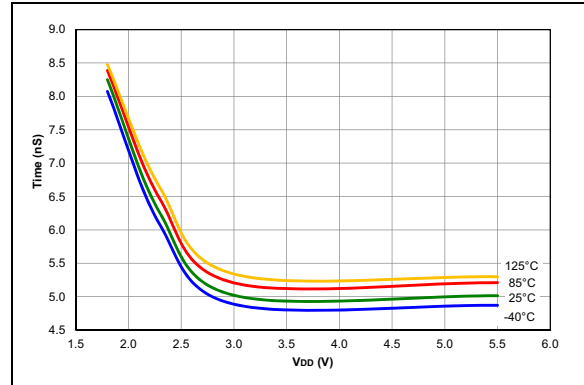


**FIGURE 37-117:** Typical DAC INL Error,  $V_{DD} = 5.0V$ ,  $V_{REF} = V_{DD}$ , PIC16F1764/5/8/9 Only.

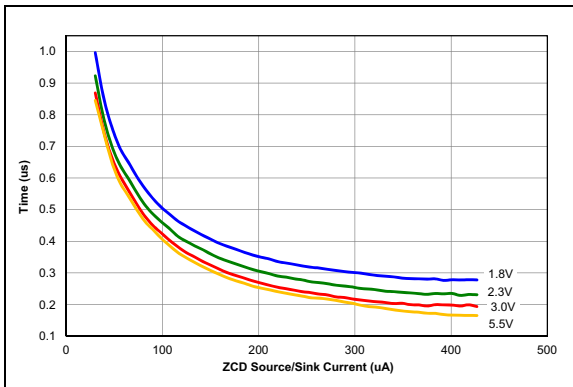
**Note:** Unless otherwise noted,  $V_{IN} = 5V$ ,  $F_{OSC} = 300\text{ kHz}$ ,  $C_{IN} = 0.1\ \mu\text{F}$ ,  $T_A = 25^\circ\text{C}$ .



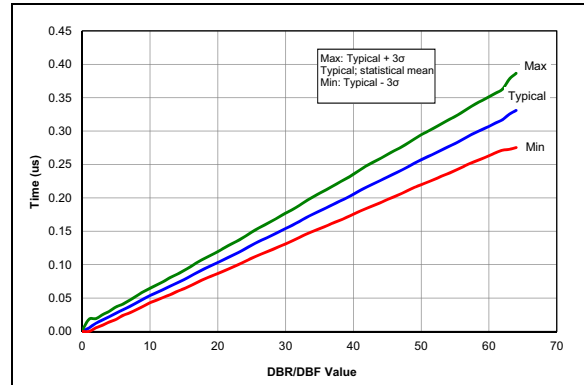
**FIGURE 37-120:** ZCD Pin Current Over ZCD Pin Voltage, Typical Measured Values from  $-40^\circ\text{C}$  to  $125^\circ\text{C}$ .



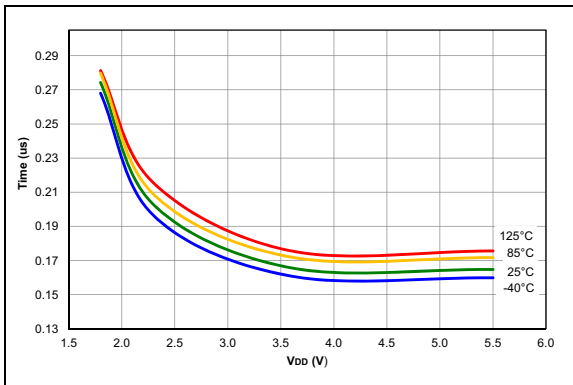
**FIGURE 37-123:** COG Dead Band DBR/DBF Delay Per Step, Typical Measured Values.



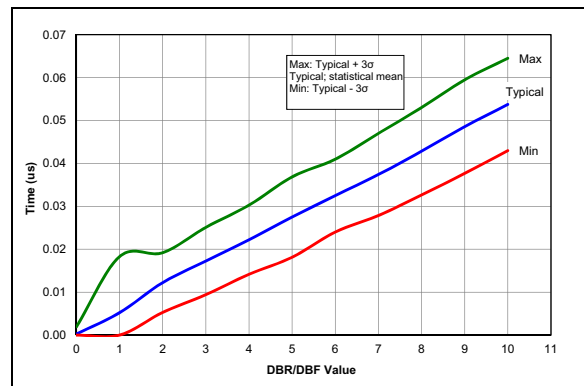
**FIGURE 37-121:** ZCD Pin Response Time Over Current, Typical Measured Values from  $-40^\circ\text{C}$  to  $125^\circ\text{C}$ .



**FIGURE 37-124:** COG Dead Band Delay Per Step, Typical Measured Values.



**FIGURE 37-122:** COG Dead Band Delay, DBR/DBF = 32, Typical Measured Values.



**FIGURE 37-125:** COG Dead Band Delay Per Step, Zoomed to First 10 Codes, Typical Measured Values.



## 38.0 DEVELOPMENT SUPPORT

The PIC<sup>®</sup> microcontrollers (MCU) and dsPIC<sup>®</sup> digital signal controllers (DSC) are supported with a full range of software and hardware development tools:

- Integrated Development Environment
  - MPLAB<sup>®</sup> X IDE Software
- Compilers/Assemblers/Linkers
  - MPLAB XC Compiler
  - MPASM<sup>™</sup> Assembler
  - MPLINK<sup>™</sup> Object Linker/  
MPLIB<sup>™</sup> Object Librarian
  - MPLAB Assembler/Linker/Librarian for  
Various Device Families
- Simulators
  - MPLAB X SIM Software Simulator
- Emulators
  - MPLAB REAL ICE<sup>™</sup> In-Circuit Emulator
- In-Circuit Debuggers/Programmers
  - MPLAB ICD 3
  - PICKit<sup>™</sup> 3
- Device Programmers
  - MPLAB PM3 Device Programmer
- Low-Cost Demonstration/Development Boards,  
Evaluation Kits and Starter Kits
- Third-party development tools

## 38.1 MPLAB X Integrated Development Environment Software

The MPLAB X IDE is a single, unified graphical user interface for Microchip and third-party software, and hardware development tool that runs on Windows<sup>®</sup>, Linux and Mac OS<sup>®</sup> X. Based on the NetBeans IDE, MPLAB X IDE is an entirely new IDE with a host of free software components and plug-ins for high-performance application development and debugging. Moving between tools and upgrading from software simulators to hardware debugging and programming tools is simple with the seamless user interface.

With complete project management, visual call graphs, a configurable watch window and a feature-rich editor that includes code completion and context menus, MPLAB X IDE is flexible and friendly enough for new users. With the ability to support multiple tools on multiple projects with simultaneous debugging, MPLAB X IDE is also suitable for the needs of experienced users.

Feature-Rich Editor:

- Color syntax highlighting
- Smart code completion makes suggestions and provides hints as you type
- Automatic code formatting based on user-defined rules
- Live parsing

User-Friendly, Customizable Interface:

- Fully customizable interface: toolbars, toolbar buttons, windows, window placement, etc.
- Call graph window

Project-Based Workspaces:

- Multiple projects
- Multiple tools
- Multiple configurations
- Simultaneous debugging sessions

File History and Bug Tracking:

- Local file history feature
- Built-in support for Bugzilla issue tracker

## 38.2 MPLAB XC Compilers

The MPLAB XC Compilers are complete ANSI C compilers for all of Microchip's 8, 16, and 32-bit MCU and DSC devices. These compilers provide powerful integration capabilities, superior code optimization and ease of use. MPLAB XC Compilers run on Windows, Linux or MAC OS X.

For easy source level debugging, the compilers provide debug information that is optimized to the MPLAB X IDE.

The free MPLAB XC Compiler editions support all devices and commands, with no time or memory restrictions, and offer sufficient code optimization for most applications.

MPLAB XC Compilers include an assembler, linker and utilities. The assembler generates relocatable object files that can then be archived or linked with other relocatable object files and archives to create an executable file. MPLAB XC Compiler uses the assembler to produce its object file. Notable features of the assembler include:

- Support for the entire device instruction set
- Support for fixed-point and floating-point data
- Command-line interface
- Rich directive set
- Flexible macro language
- MPLAB X IDE compatibility

## 38.3 MPASM Assembler

The MPASM Assembler is a full-featured, universal macro assembler for PIC10/12/16/18 MCUs.

The MPASM Assembler generates relocatable object files for the MPLINK Object Linker, Intel® standard HEX files, MAP files to detail memory usage and symbol reference, absolute LST files that contain source lines and generated machine code, and COFF files for debugging.

The MPASM Assembler features include:

- Integration into MPLAB X IDE projects
- User-defined macros to streamline assembly code
- Conditional assembly for multipurpose source files
- Directives that allow complete control over the assembly process

## 38.4 MPLINK Object Linker/ MPLIB Object Librarian

The MPLINK Object Linker combines relocatable objects created by the MPASM Assembler. It can link relocatable objects from precompiled libraries, using directives from a linker script.

The MPLIB Object Librarian manages the creation and modification of library files of precompiled code. When a routine from a library is called from a source file, only the modules that contain that routine will be linked in with the application. This allows large libraries to be used efficiently in many different applications.

The object linker/librarian features include:

- Efficient linking of single libraries instead of many smaller files
- Enhanced code maintainability by grouping related modules together
- Flexible creation of libraries with easy module listing, replacement, deletion and extraction

## 38.5 MPLAB Assembler, Linker and Librarian for Various Device Families

MPLAB Assembler produces relocatable machine code from symbolic assembly language for PIC24, PIC32 and dsPIC DSC devices. MPLAB XC Compiler uses the assembler to produce its object file. The assembler generates relocatable object files that can then be archived or linked with other relocatable object files and archives to create an executable file. Notable features of the assembler include:

- Support for the entire device instruction set
- Support for fixed-point and floating-point data
- Command-line interface
- Rich directive set
- Flexible macro language
- MPLAB X IDE compatibility

## 38.6 MPLAB X SIM Software Simulator

The MPLAB X SIM Software Simulator allows code development in a PC-hosted environment by simulating the PIC MCUs and dsPIC DSCs on an instruction level. On any given instruction, the data areas can be examined or modified and stimuli can be applied from a comprehensive stimulus controller. Registers can be logged to files for further run-time analysis. The trace buffer and logic analyzer display extend the power of the simulator to record and track program execution, actions on I/O, most peripherals and internal registers.

The MPLAB X SIM Software Simulator fully supports symbolic debugging using the MPLAB XC Compilers, and the MPASM and MPLAB Assemblers. The software simulator offers the flexibility to develop and debug code outside of the hardware laboratory environment, making it an excellent, economical software development tool.

## 38.7 MPLAB REAL ICE In-Circuit Emulator System

The MPLAB REAL ICE In-Circuit Emulator System is Microchip's next generation high-speed emulator for Microchip Flash DSC and MCU devices. It debugs and programs all 8, 16 and 32-bit MCU, and DSC devices with the easy-to-use, powerful graphical user interface of the MPLAB X IDE.

The emulator is connected to the design engineer's PC using a high-speed USB 2.0 interface and is connected to the target with either a connector compatible with in-circuit debugger systems (RJ-11) or with the new high-speed, noise tolerant, Low-Voltage Differential Signal (LVDS) interconnection (CAT5).

The emulator is field upgradeable through future firmware downloads in MPLAB X IDE. MPLAB REAL ICE offers significant advantages over competitive emulators including full-speed emulation, run-time variable watches, trace analysis, complex breakpoints, logic probes, a ruggedized probe interface and long (up to three meters) interconnection cables.

## 38.8 MPLAB ICD 3 In-Circuit Debugger System

The MPLAB ICD 3 In-Circuit Debugger System is Microchip's most cost-effective, high-speed hardware debugger/programmer for Microchip Flash DSC and MCU devices. It debugs and programs PIC Flash microcontrollers and dsPIC DSCs with the powerful, yet easy-to-use graphical user interface of the MPLAB IDE.

The MPLAB ICD 3 In-Circuit Debugger probe is connected to the design engineer's PC using a high-speed USB 2.0 interface and is connected to the target with a connector compatible with the MPLAB ICD 2 or MPLAB REAL ICE systems (RJ-11). MPLAB ICD 3 supports all MPLAB ICD 2 headers.

## 38.9 PICkit 3 In-Circuit Debugger/Programmer

The MPLAB PICkit 3 allows debugging and programming of PIC and dsPIC Flash microcontrollers at a most affordable price point using the powerful graphical user interface of the MPLAB IDE. The MPLAB PICkit 3 is connected to the design engineer's PC using a full-speed USB interface and can be connected to the target via a Microchip debug (RJ-11) connector (compatible with MPLAB ICD 3 and MPLAB REAL ICE). The connector uses two device I/O pins and the Reset line to implement in-circuit debugging and In-Circuit Serial Programming™ (ICSP™).

## 38.10 MPLAB PM3 Device Programmer

The MPLAB PM3 Device Programmer is a universal, CE compliant device programmer with programmable voltage verification at VDDMIN and VDDMAX for maximum reliability. It features a large LCD display (128 x 64) for menus and error messages, and a modular, detachable socket assembly to support various package types. The ICSP cable assembly is included as a standard item. In Stand-Alone mode, the MPLAB PM3 Device Programmer can read, verify and program PIC devices without a PC connection. It can also set code protection in this mode. The MPLAB PM3 connects to the host PC via an RS-232 or USB cable. The MPLAB PM3 has high-speed communications and optimized algorithms for quick programming of large memory devices, and incorporates an MMC card for file storage and data applications.

## 38.11 Demonstration/Development Boards, Evaluation Kits, and Starter Kits

A wide variety of demonstration, development and evaluation boards for various PIC MCUs and dsPIC DSCs allows quick application development on fully functional systems. Most boards include prototyping areas for adding custom circuitry and provide application firmware and source code for examination and modification.

The boards support a variety of features, including LEDs, temperature sensors, switches, speakers, RS-232 interfaces, LCD displays, potentiometers and additional EEPROM memory.

The demonstration and development boards can be used in teaching environments, for prototyping custom circuits and for learning about various microcontroller applications.

In addition to the PICDEM™ and dsPICDEM™ demonstration/development board series of circuits, Microchip has a line of evaluation kits and demonstration software for analog filter design, KEELOQ® security ICs, CAN, IrDA®, PowerSmart battery management, SEEVAL® evaluation system, Sigma-Delta ADC, flow rate sensing, plus many more.

Also available are starter kits that contain everything needed to experience the specified device. This usually includes a single application and debug capability, all on one board.

Check the Microchip web page ([www.microchip.com](http://www.microchip.com)) for the complete list of demonstration, development and evaluation kits.

## 38.12 Third-Party Development Tools

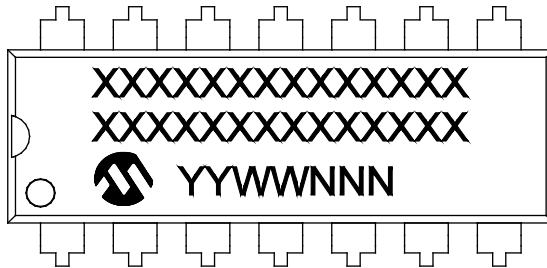
Microchip also offers a great collection of tools from third-party vendors. These tools are carefully selected to offer good value and unique functionality.

- Device Programmers and Gang Programmers from companies, such as SoftLog and CCS
- Software Tools from companies, such as Gimpel and Trace Systems
- Protocol Analyzers from companies, such as Saleae and Total Phase
- Demonstration Boards from companies, such as MikroElektronika, Digilent® and Olimex
- Embedded Ethernet Solutions from companies, such as EZ Web Lynx, WIZnet and IPLogika®

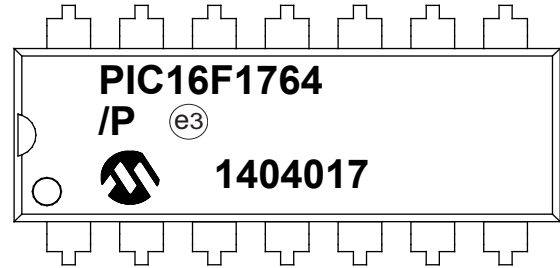
## 39.0 PACKAGING INFORMATION

### 39.1 Package Marking Information

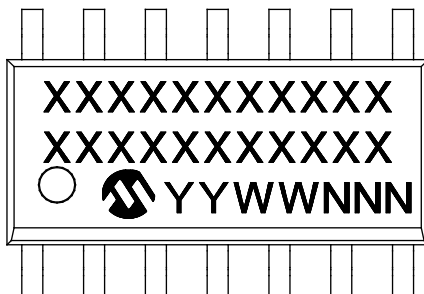
14-Lead PDIP (300 mil)



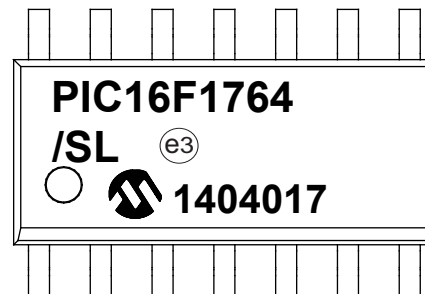
Example



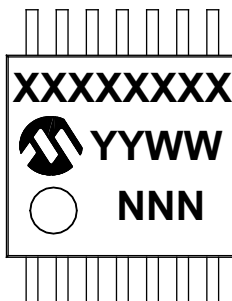
14-Lead SOIC (3.90 mm)



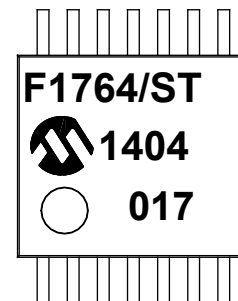
Example



14-Lead TSSOP (4.4 mm)



Example



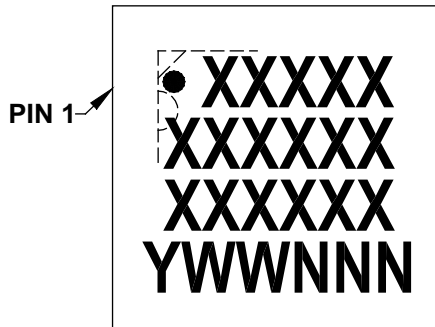
<b>Legend:</b>	XX...X	Customer-specific information
	Y	Year code (last digit of calendar year)
	YY	Year code (last 2 digits of calendar year)
	WW	Week code (week of January 1 is week '01')
	NNN	Alphanumeric traceability code
	(e3)	Pb-free JEDEC® designator for Matte Tin (Sn)
	*	This package is Pb-free. The Pb-free JEDEC® designator (e3) can be found on the outer packaging for this package.

**Note:** In the event the full Microchip part number cannot be marked on one line, it will be carried over to the next line, thus limiting the number of available characters for customer-specific information.

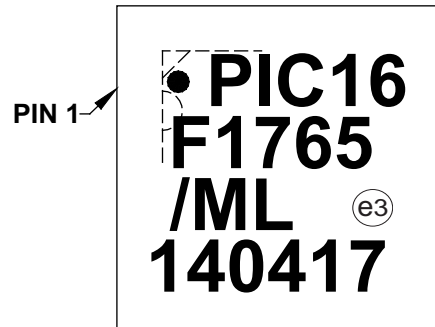
# PIC16(L)F1764/5/8/9

## Package Marking Information (Continued)

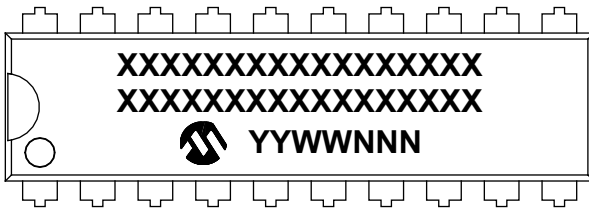
16-Lead QFN (4x4x0.9 mm)



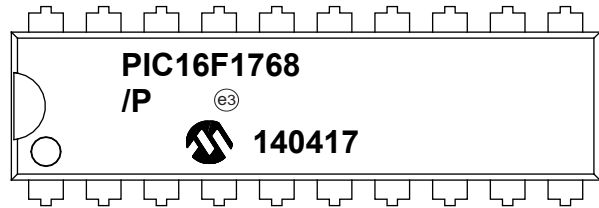
Example



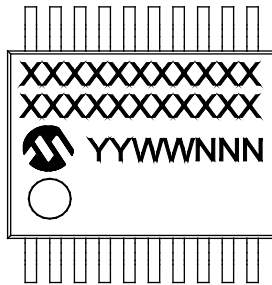
20-Lead PDIP (300 mil)



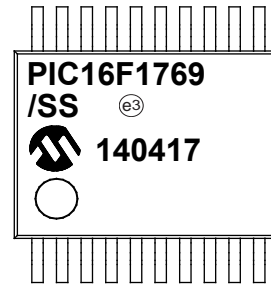
Example



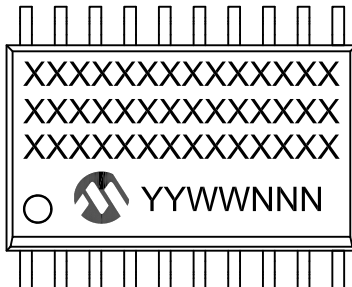
20-Lead SSOP (5.30 mm)



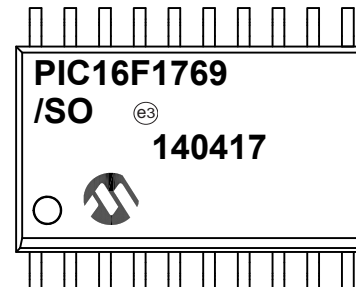
Example



20-Lead SOIC (7.50 mm)

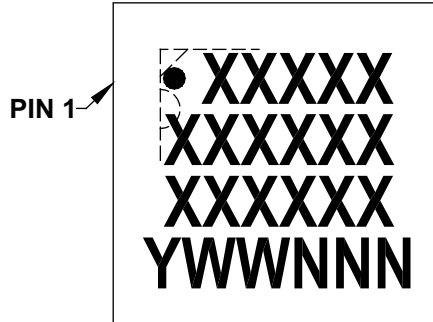


Example

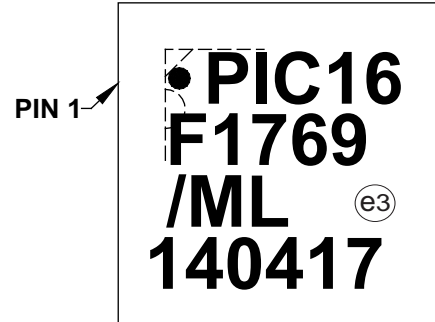


## Package Marking Information (Continued)

20-Lead QFN (4x4x0.9 mm)



Example



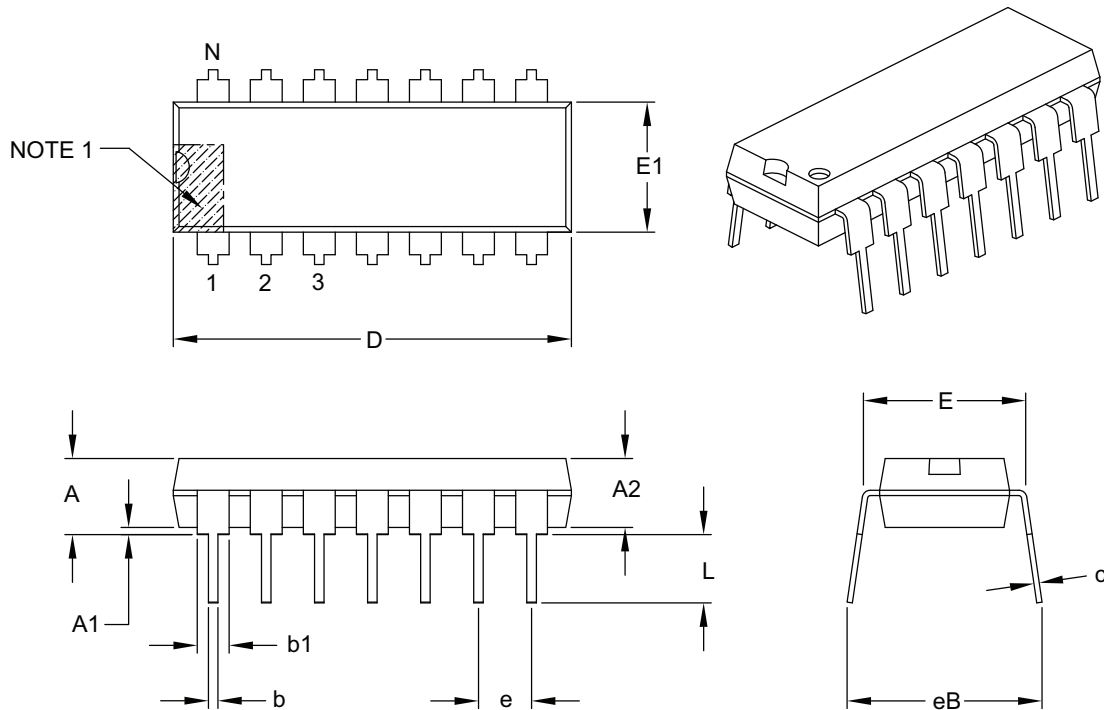
# PIC16(L)F1764/5/8/9

## 39.2 Package Details

The following sections give the technical details of the packages.

### 14-Lead Plastic Dual In-Line (P) – 300 mil Body [PDIP]

**Note:** For the most current package drawings, please see the Microchip Packaging Specification located at <http://www.microchip.com/packaging>



Dimension Limits	Units	INCHES		
		MIN	NOM	MAX
Number of Pins	N	14		
Pitch	e	.100 BSC		
Top to Seating Plane	A	–	–	.210
Molded Package Thickness	A2	.115	.130	.195
Base to Seating Plane	A1	.015	–	–
Shoulder to Shoulder Width	E	.290	.310	.325
Molded Package Width	E1	.240	.250	.280
Overall Length	D	.735	.750	.775
Tip to Seating Plane	L	.115	.130	.150
Lead Thickness	c	.008	.010	.015
Upper Lead Width	b1	.045	.060	.070
Lower Lead Width	b	.014	.018	.022
Overall Row Spacing §	eB	–	–	.430

**Notes:**

1. Pin 1 visual index feature may vary, but must be located with the hatched area.
2. § Significant Characteristic.
3. Dimensions D and E1 do not include mold flash or protrusions. Mold flash or protrusions shall not exceed .010" per side.
4. Dimensioning and tolerancing per ASME Y14.5M.

BSC: Basic Dimension. Theoretically exact value shown without tolerances.

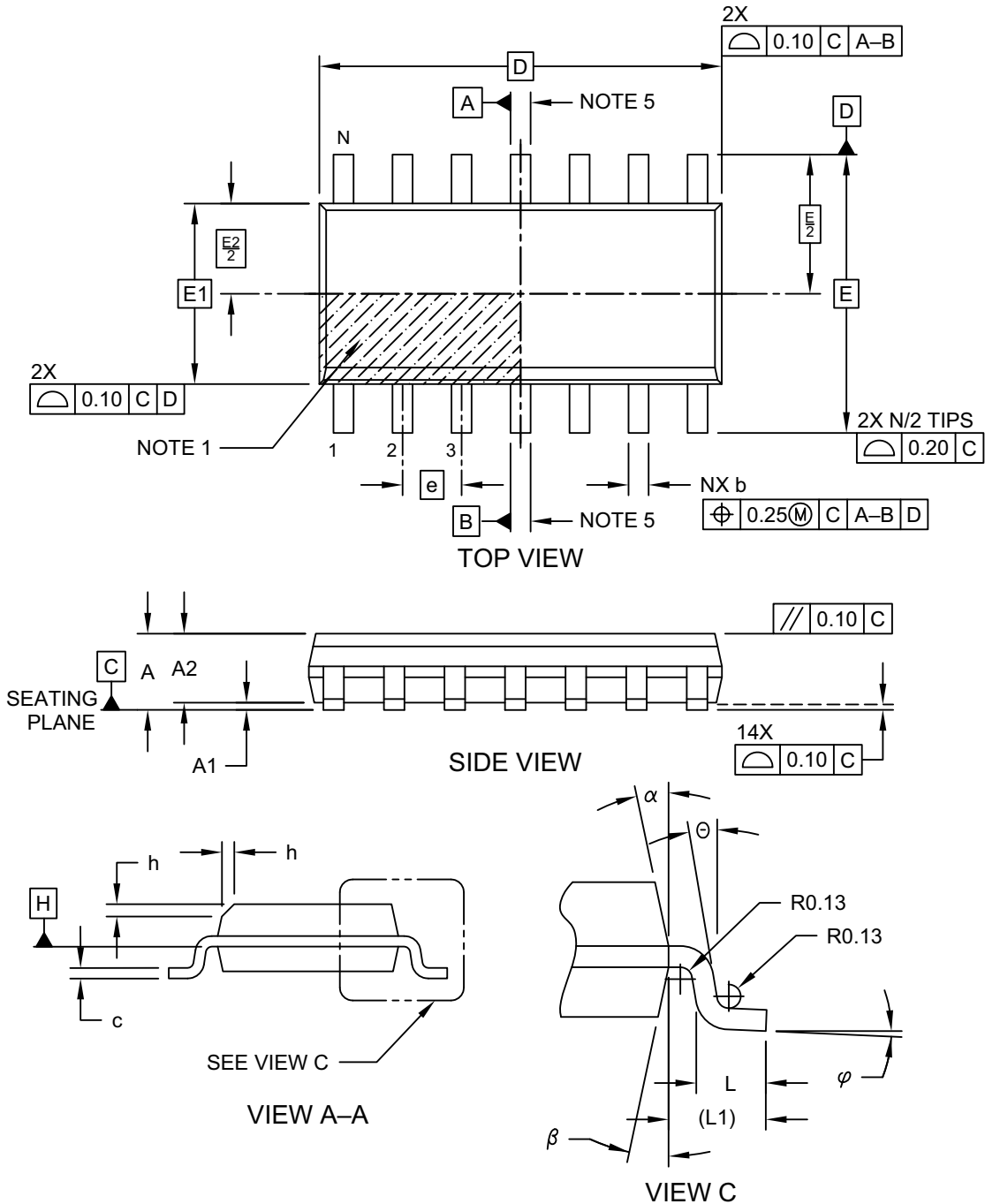
Microchip Technology Drawing C04-005B



# PIC16(L)F1764/5/8/9

## 14-Lead Plastic Small Outline (SL) - Narrow, 3.90 mm Body [SOIC]

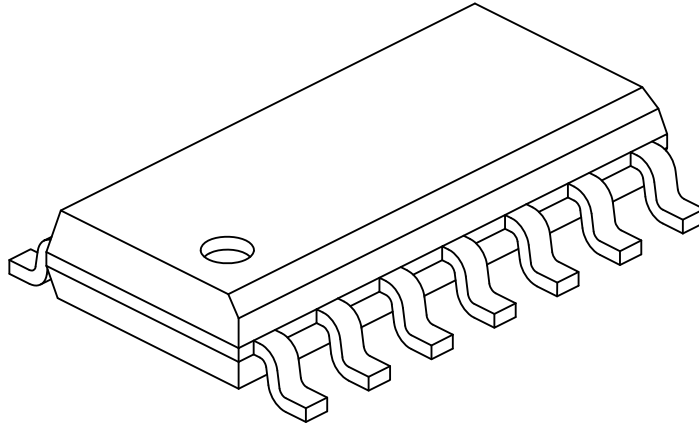
**Note:** For the most current package drawings, please see the Microchip Packaging Specification located at <http://www.microchip.com/packaging>



# PIC16(L)F1764/5/8/9

## 14-Lead Plastic Small Outline (SL) - Narrow, 3.90 mm Body [SOIC]

**Note:** For the most current package drawings, please see the Microchip Packaging Specification located at <http://www.microchip.com/packaging>



Dimension Limits	Units	MILLIMETERS		
		MIN	NOM	MAX
Number of Pins	N	14		
Pitch	e	1.27 BSC		
Overall Height	A	-	-	1.75
Molded Package Thickness	A2	1.25	-	-
Standoff §	A1	0.10	-	0.25
Overall Width	E	6.00 BSC		
Molded Package Width	E1	3.90 BSC		
Overall Length	D	8.65 BSC		
Chamfer (Optional)	h	0.25	-	0.50
Foot Length	L	0.40	-	1.27
Footprint	L1	1.04 REF		
Lead Angle	θ	0°	-	-
Foot Angle	φ	0°	-	8°
Lead Thickness	c	0.10	-	0.25
Lead Width	b	0.31	-	0.51
Mold Draft Angle Top	α	5°	-	15°
Mold Draft Angle Bottom	β	5°	-	15°

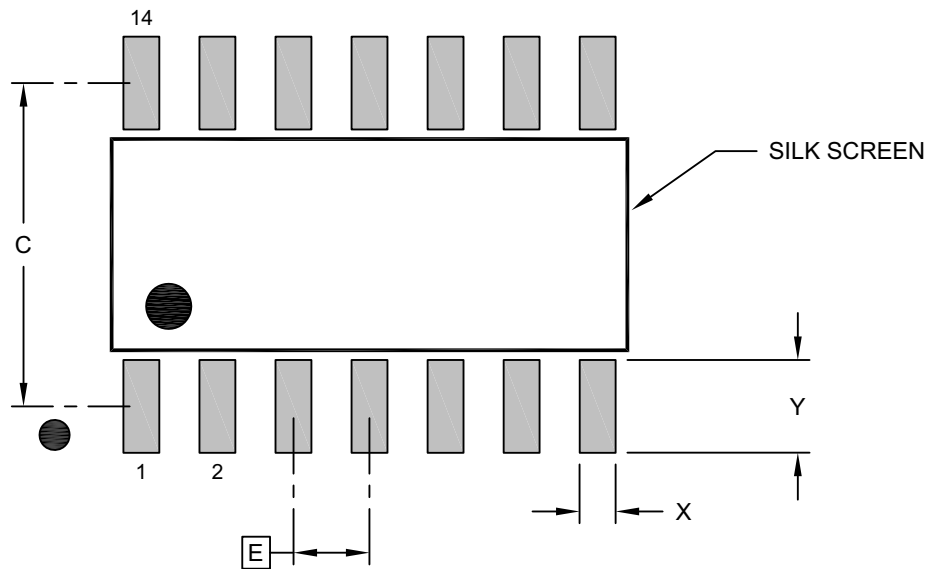
### Notes:

1. Pin 1 visual index feature may vary, but must be located within the hatched area.
2. § Significant Characteristic
3. Dimension D does not include mold flash, protrusions or gate burrs, which shall not exceed 0.15 mm per end. Dimension E1 does not include interlead flash or protrusion, which shall not exceed 0.25 mm per side.
4. Dimensioning and tolerancing per ASME Y14.5M
  - BSC: Basic Dimension. Theoretically exact value shown without tolerances.
  - REF: Reference Dimension, usually without tolerance, for information purposes only.
5. Datums A & B to be determined at Datum H.

Microchip Technology Drawing No. C04-065-SL Rev D Sheet 2 of 2

## 14-Lead Plastic Small Outline (SL) - Narrow, 3.90 mm Body [SOIC]

**Note:** For the most current package drawings, please see the Microchip Packaging Specification located at <http://www.microchip.com/packaging>



### RECOMMENDED LAND PATTERN

Dimension Limits	Units	MILLIMETERS		
		MIN	NOM	MAX
Contact Pitch	E		1.27 BSC	
Contact Pad Spacing	C		5.40	
Contact Pad Width (X14)	X			0.60
Contact Pad Length (X14)	Y			1.55

**Notes:**

1. Dimensioning and tolerancing per ASME Y14.5M

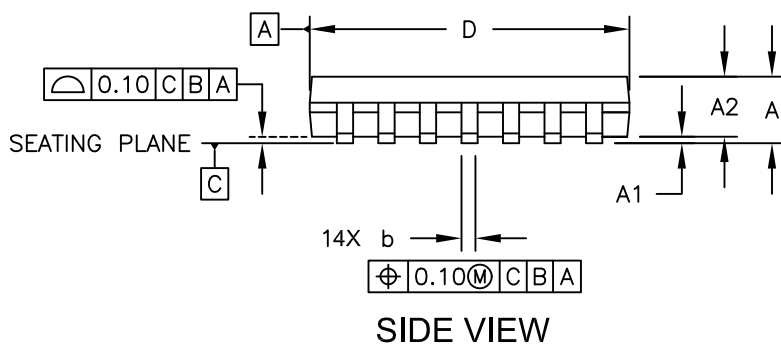
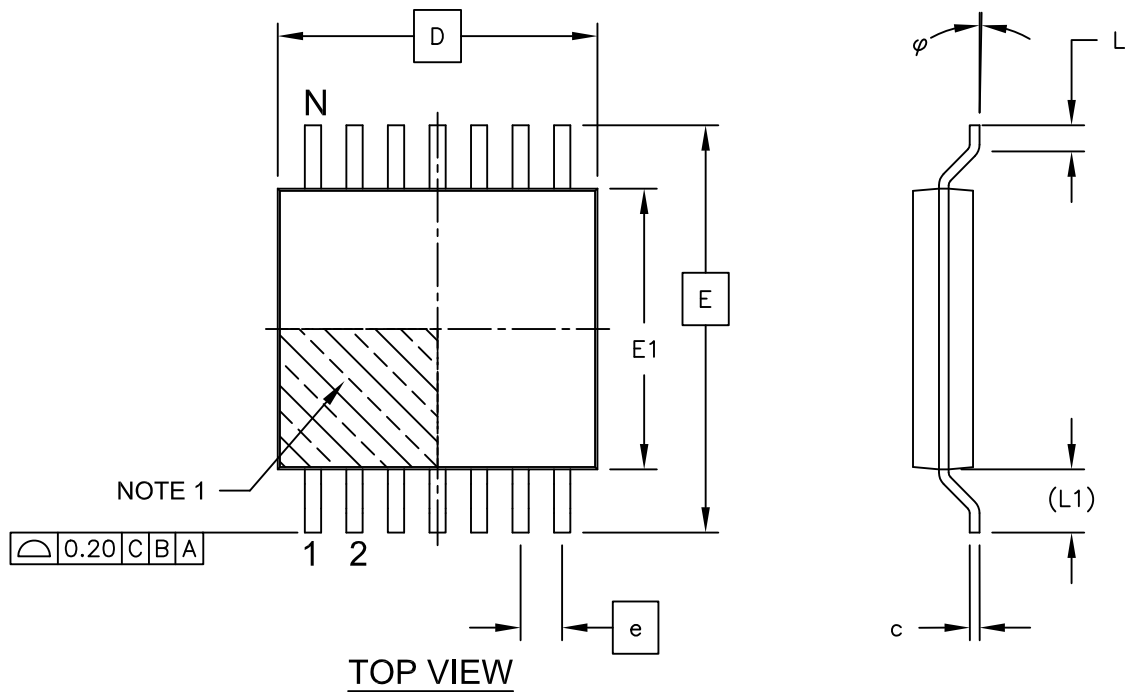
BSC: Basic Dimension. Theoretically exact value shown without tolerances.

Microchip Technology Drawing No. C04-2065-SL Rev D

# PIC16(L)F1764/5/8/9

## 14-Lead Plastic Thin Shrink Small Outline (ST) - 4.4 mm Body [TSSOP]

**Note:** For the most current package drawings, please see the Microchip Packaging Specification located at <http://www.microchip.com/packaging>

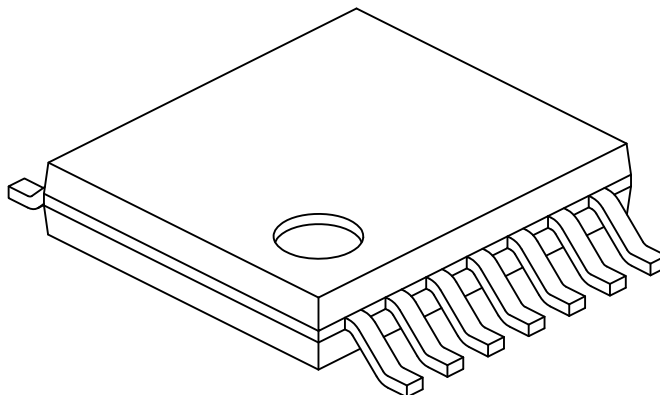


Microchip Technology Drawing C04-087C Sheet 1 of 2

# PIC16(L)F1764/5/8/9

## 14-Lead Plastic Thin Shrink Small Outline (ST) - 4.4 mm Body [TSSOP]

**Note:** For the most current package drawings, please see the Microchip Packaging Specification located at <http://www.microchip.com/packaging>



Units		MILLIMETERS		
Dimension Limits		MIN	NOM	MAX
Number of Pins	N	14		
Pitch	e	0.65 BSC		
Overall Height	A	-	-	1.20
Molded Package Thickness	A2	0.80	1.00	1.05
Standoff	A1	0.05	-	0.15
Overall Width	E	6.40 BSC		
Molded Package Width	E1	4.30	4.40	4.50
Molded Package Length	D	4.90	5.00	5.10
Foot Length	L	0.45	0.60	0.75
Footprint	(L1)	1.00 REF		
Foot Angle	$\varphi$	0°	-	8°
Lead Thickness	c	0.09	-	0.20
Lead Width	b	0.19	-	0.30

**Notes:**

- Pin 1 visual index feature may vary, but must be located within the hatched area.
- Dimensions D and E1 do not include mold flash or protrusions. Mold flash or protrusions shall not exceed 0.15mm per side.
- Dimensioning and tolerancing per ASME Y14.5M

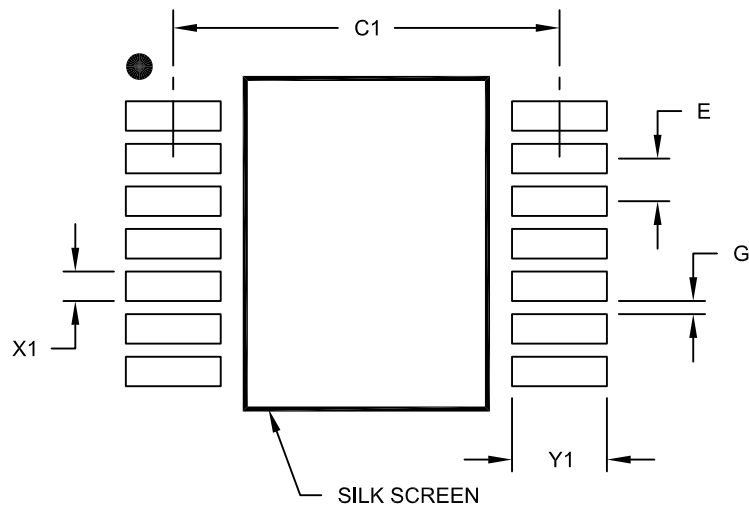
BSC: Basic Dimension. Theoretically exact value shown without tolerances.

REF: Reference Dimension, usually without tolerance, for information purposes only.

Microchip Technology Drawing No. C04-087C Sheet 2 of 2

## 14-Lead Plastic Thin Shrink Small Outline (ST) - 4.4 mm Body [TSSOP]

**Note:** For the most current package drawings, please see the Microchip Packaging Specification located at <http://www.microchip.com/packaging>



RECOMMENDED LAND PATTERN

Dimension Limits	Units	MILLIMETERS		
		MIN	NOM	MAX
Contact Pitch	E	0.65 BSC		
Contact Pad Spacing	C1		5.90	
Contact Pad Width (X14)	X1			0.45
Contact Pad Length (X14)	Y1			1.45
Distance Between Pads	G	0.20		

**Notes:**

1. Dimensioning and tolerancing per ASME Y14.5M

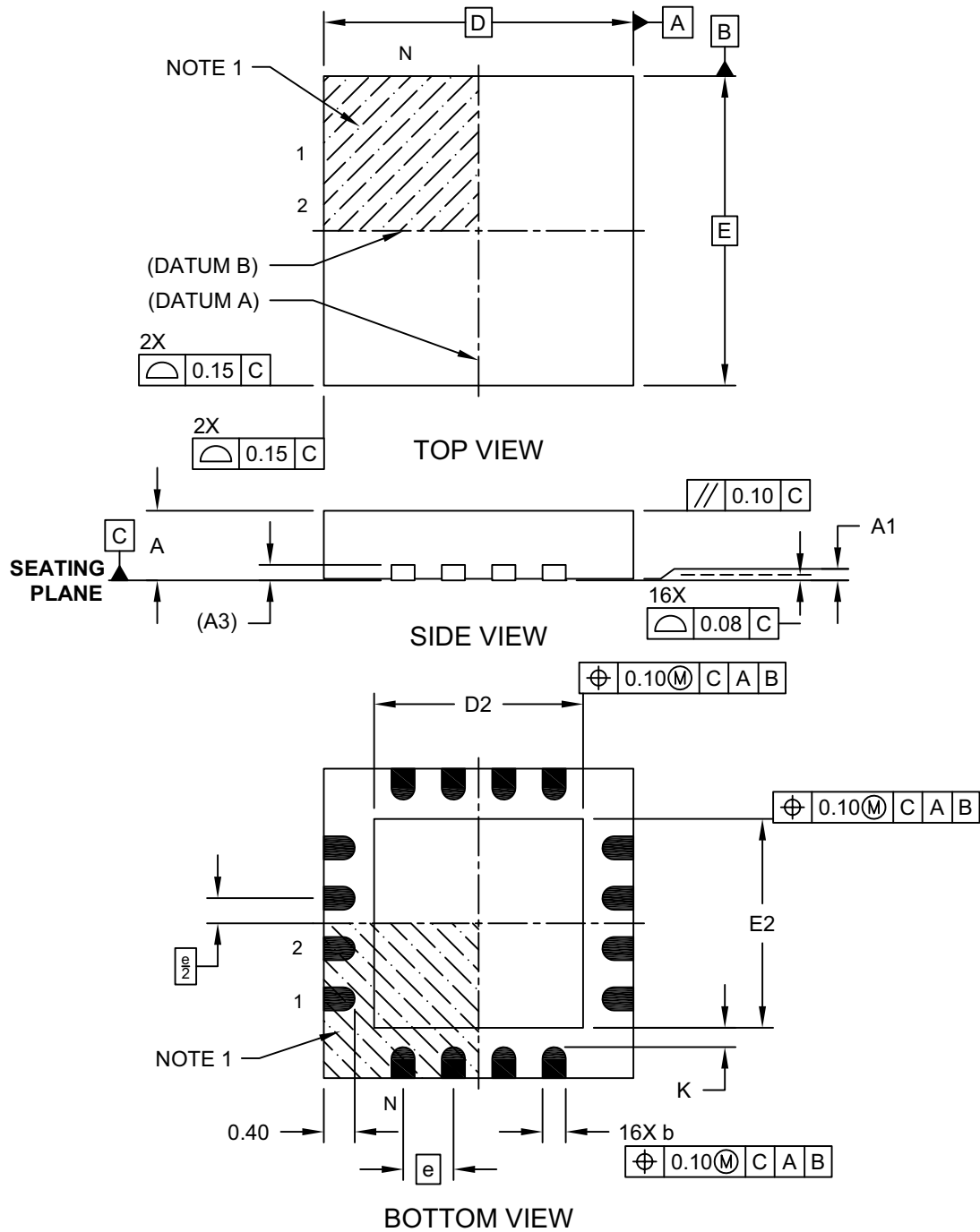
BSC: Basic Dimension. Theoretically exact value shown without tolerances.

Microchip Technology Drawing No. C04-2087A

# PIC16(L)F1764/5/8/9

## 16-Lead Plastic Quad Flat, No Lead Package (ML) - 4x4x0.9mm Body [QFN]

**Note:** For the most current package drawings, please see the Microchip Packaging Specification located at <http://www.microchip.com/packaging>

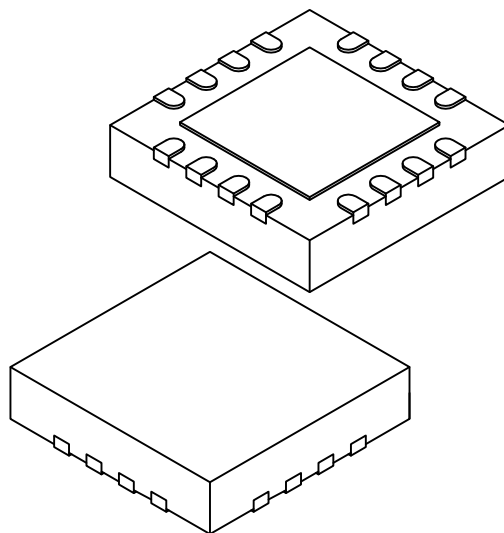


Microchip Technology Drawing C04-127D Sheet 1 of 2

# PIC16(L)F1764/5/8/9

## 16-Lead Plastic Quad Flat, No Lead Package (ML) - 4x4x0.9mm Body [QFN]

**Note:** For the most current package drawings, please see the Microchip Packaging Specification located at <http://www.microchip.com/packaging>



		Units	MILLIMETERS		
Dimension Limits			MIN	NOM	MAX
Number of Pins	N		16		
Pitch	e		0.65 BSC		
Overall Height	A		0.80	0.90	1.00
Standoff	A1		0.00	0.02	0.05
Contact Thickness	A3		0.20 REF		
Overall Width	E		4.00 BSC		
Exposed Pad Width	E2		2.50	2.65	2.80
Overall Length	D		4.00 BSC		
Exposed Pad Length	D2		2.50	2.65	2.80
Contact Width	b		0.25	0.30	0.35
Contact Length	L		0.30	0.40	0.50
Contact-to-Exposed Pad	K		0.20	-	-

**Notes:**

1. Pin 1 visual index feature may vary, but must be located within the hatched area.
2. Package is saw singulated
3. Dimensioning and tolerancing per ASME Y14.5M

BSC: Basic Dimension. Theoretically exact value shown without tolerances.

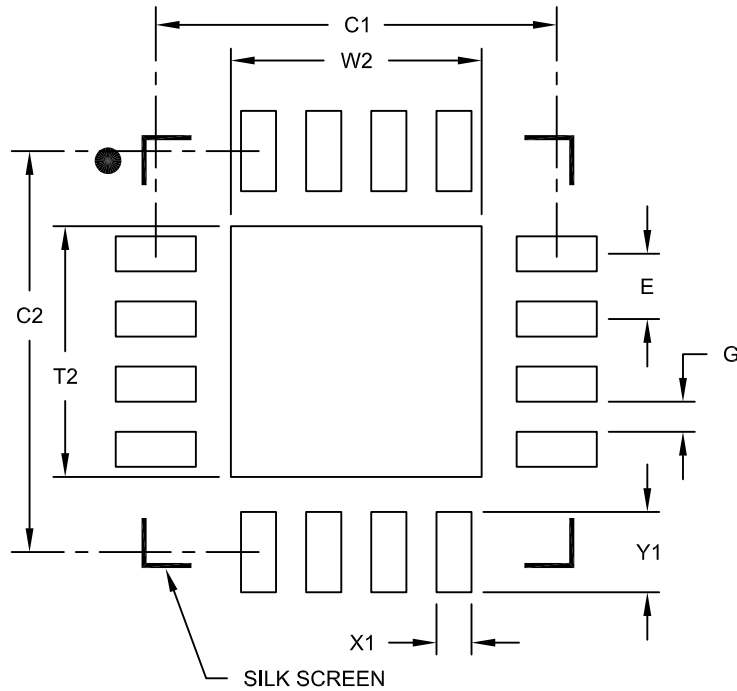
REF: Reference Dimension, usually without tolerance, for information purposes only.

Microchip Technology Drawing C04-127D Sheet 2 of 2



## 16-Lead Plastic Quad Flat, No Lead Package (ML) - 4x4x0.9mm Body [QFN]

**Note:** For the most current package drawings, please see the Microchip Packaging Specification located at <http://www.microchip.com/packaging>



RECOMMENDED LAND PATTERN

Dimension Limits	Units	MILLIMETERS		
		MIN	NOM	MAX
Contact Pitch	E	0.65 BSC		
Optional Center Pad Width	W2			2.50
Optional Center Pad Length	T2			2.50
Contact Pad Spacing	C1		4.00	
Contact Pad Spacing	C2		4.00	
Contact Pad Width (X16)	X1			0.35
Contact Pad Length (X16)	Y1			0.80
Distance Between Pads	G	0.30		

**Notes:**

1. Dimensioning and tolerancing per ASME Y14.5M

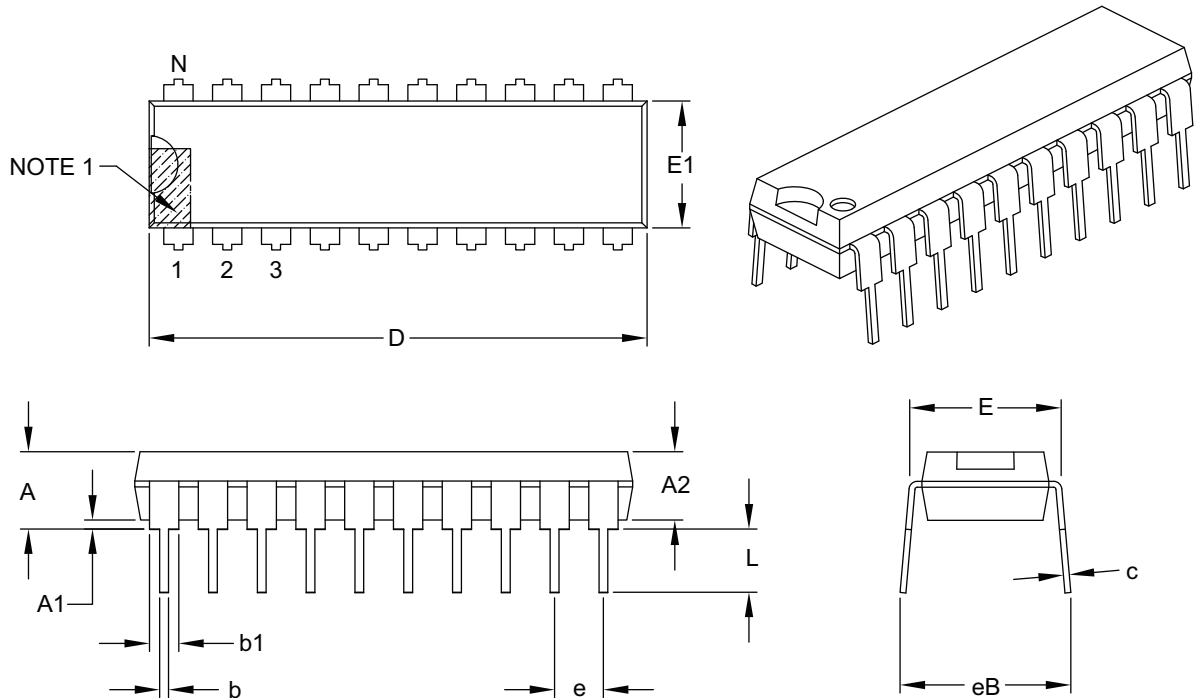
BSC: Basic Dimension. Theoretically exact value shown without tolerances.

Microchip Technology Drawing No. C04-2127A

# PIC16(L)F1764/5/8/9

## 20-Lead Plastic Dual In-Line (P) – 300 mil Body [PDIP]

**Note:** For the most current package drawings, please see the Microchip Packaging Specification located at <http://www.microchip.com/packaging>



Dimension Limits	Units	INCHES		
		MIN	NOM	MAX
Number of Pins	N	20		
Pitch	e	.100 BSC		
Top to Seating Plane	A	–	–	.210
Molded Package Thickness	A2	.115	.130	.195
Base to Seating Plane	A1	.015	–	–
Shoulder to Shoulder Width	E	.300	.310	.325
Molded Package Width	E1	.240	.250	.280
Overall Length	D	.980	1.030	1.060
Tip to Seating Plane	L	.115	.130	.150
Lead Thickness	c	.008	.010	.015
Upper Lead Width	b1	.045	.060	.070
Lower Lead Width	b	.014	.018	.022
Overall Row Spacing §	eB	–	–	.430

**Notes:**

- Pin 1 visual index feature may vary, but must be located within the hatched area.
- § Significant Characteristic.
- Dimensions D and E1 do not include mold flash or protrusions. Mold flash or protrusions shall not exceed .010" per side.
- Dimensioning and tolerancing per ASME Y14.5M.

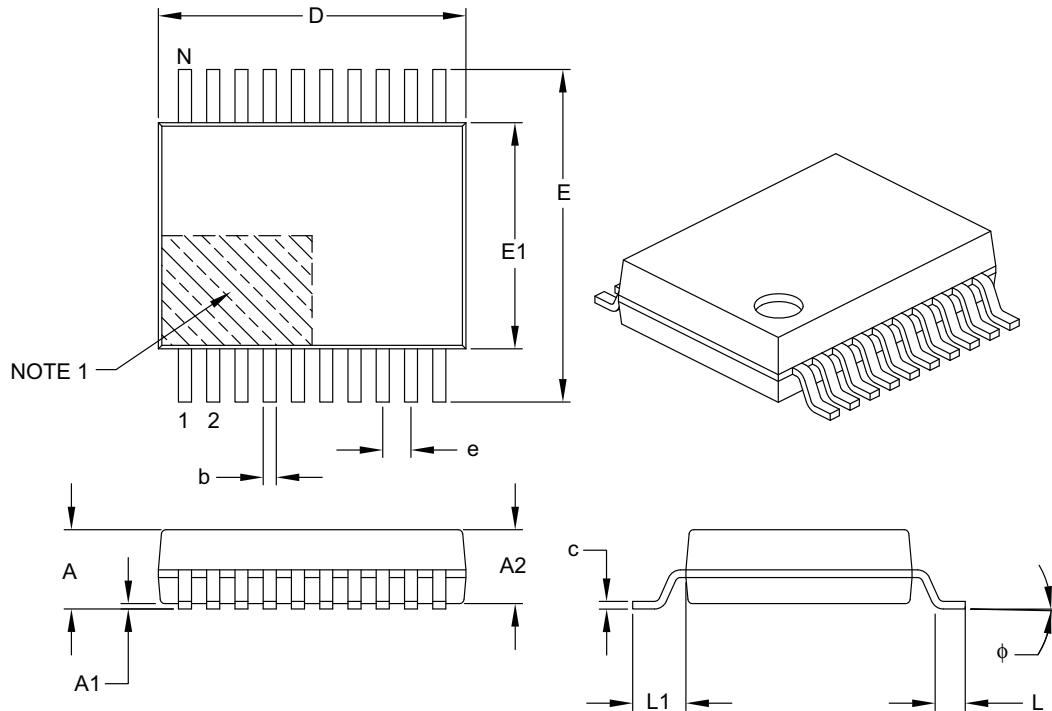
BSC: Basic Dimension. Theoretically exact value shown without tolerances.

Microchip Technology Drawing C04-019B

# PIC16(L)F1764/5/8/9

## 20-Lead Plastic Shrink Small Outline (SS) – 5.30 mm Body [SSOP]

**Note:** For the most current package drawings, please see the Microchip Packaging Specification located at <http://www.microchip.com/packaging>



		Units	MILLIMETERS		
Dimension Limits			MIN	NOM	MAX
Number of Pins	N		20		
Pitch	e		0.65 BSC		
Overall Height	A	–	–	–	2.00
Molded Package Thickness	A2	1.65	1.75	1.85	–
Standoff	A1	0.05	–	–	–
Overall Width	E	7.40	7.80	8.20	–
Molded Package Width	E1	5.00	5.30	5.60	–
Overall Length	D	6.90	7.20	7.50	–
Foot Length	L	0.55	0.75	0.95	–
Footprint	L1		1.25 REF		
Lead Thickness	c	0.09	–	–	0.25
Foot Angle	$\phi$	0°	4°	8°	–
Lead Width	b	0.22	–	–	0.38

**Notes:**

- Pin 1 visual index feature may vary, but must be located within the hatched area.
- Dimensions D and E1 do not include mold flash or protrusions. Mold flash or protrusions shall not exceed 0.20 mm per side.
- Dimensioning and tolerancing per ASME Y14.5M.

BSC: Basic Dimension. Theoretically exact value shown without tolerances.

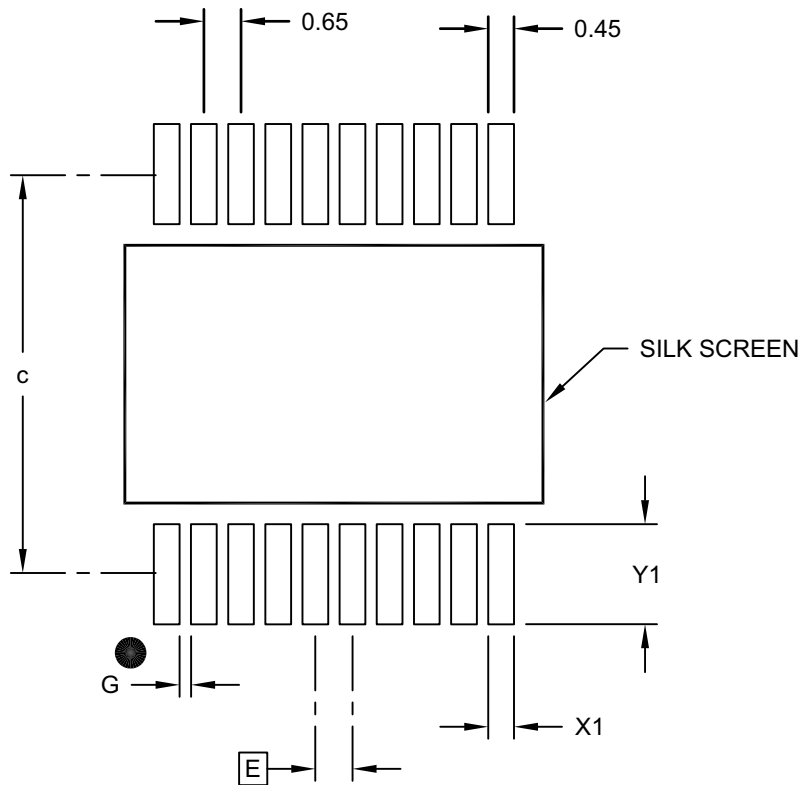
REF: Reference Dimension, usually without tolerance, for information purposes only.

Microchip Technology Drawing C04-072B

# PIC16(L)F1764/5/8/9

## 20-Lead Plastic Shrink Small Outline (SS) - 5.30 mm Body [SSOP]

**Note:** For the most current package drawings, please see the Microchip Packaging Specification located at <http://www.microchip.com/packaging>



### RECOMMENDED LAND PATTERN

Dimension Limits	Units	MILLIMETERS		
		MIN	NOM	MAX
Contact Pitch	E	0.65 BSC		
Contact Pad Spacing	C		7.20	
Contact Pad Width (X20)	X1			0.45
Contact Pad Length (X20)	Y1			1.75
Distance Between Pads	G	0.20		

**Notes:**

1. Dimensioning and tolerancing per ASME Y14.5M

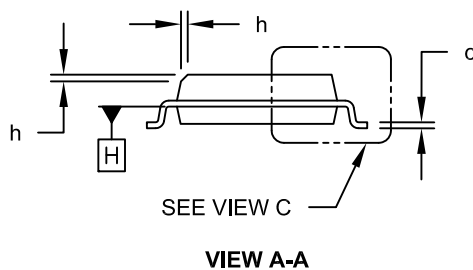
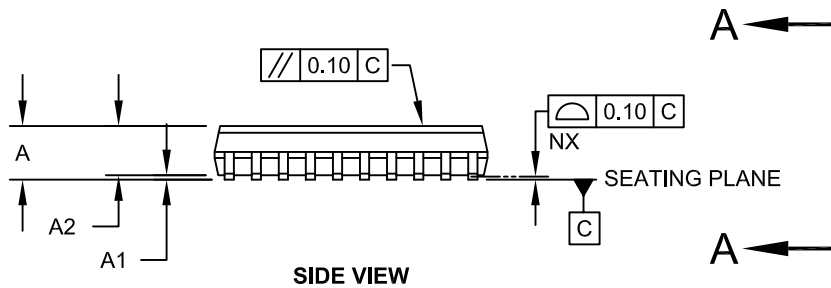
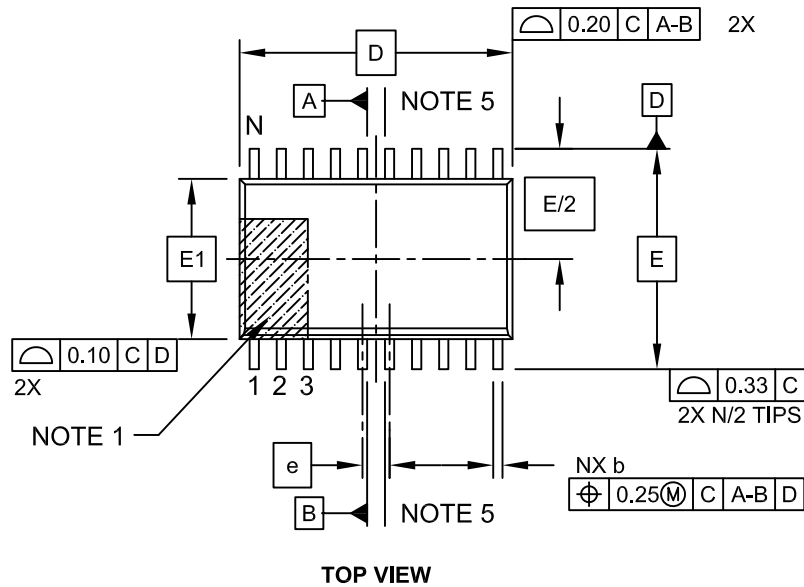
BSC: Basic Dimension. Theoretically exact value shown without tolerances.

Microchip Technology Drawing No. C04-2072B

# PIC16(L)F1764/5/8/9

## 20-Lead Plastic Small Outline (SO) - Wide, 7.50 mm Body [SOIC]

**Note:** For the most current package drawings, please see the Microchip Packaging Specification located at <http://www.microchip.com/packaging>

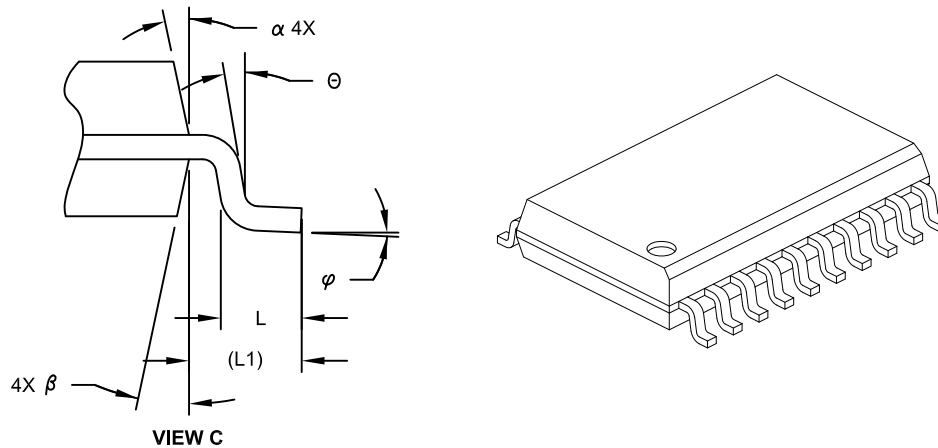


Microchip Technology Drawing C04-094C Sheet 1 of 2

# PIC16(L)F1764/5/8/9

## 20-Lead Plastic Small Outline (SO) - Wide, 7.50 mm Body [SOIC]

**Note:** For the most current package drawings, please see the Microchip Packaging Specification located at <http://www.microchip.com/packaging>



Dimension Limits	Units	MILLIMETERS		
		MIN	NOM	MAX
Number of Pins	N	20		
Pitch	e	1.27 BSC		
Overall Height	A	-	-	2.65
Molded Package Thickness	A2	2.05	-	-
Standoff §	A1	0.10	-	0.30
Overall Width	E	10.30 BSC		
Molded Package Width	E1	7.50 BSC		
Overall Length	D	12.80 BSC		
Chamfer (Optional)	h	0.25	-	0.75
Foot Length	L	0.40	-	1.27
Footprint	L1	1.40 REF		
Lead Angle	θ	0°	-	-
Foot Angle	φ	0°	-	8°
Lead Thickness	c	0.20	-	0.33
Lead Width	b	0.31	-	0.51
Mold Draft Angle Top	α	5°	-	15°
Mold Draft Angle Bottom	β	5°	-	15°

### Notes:

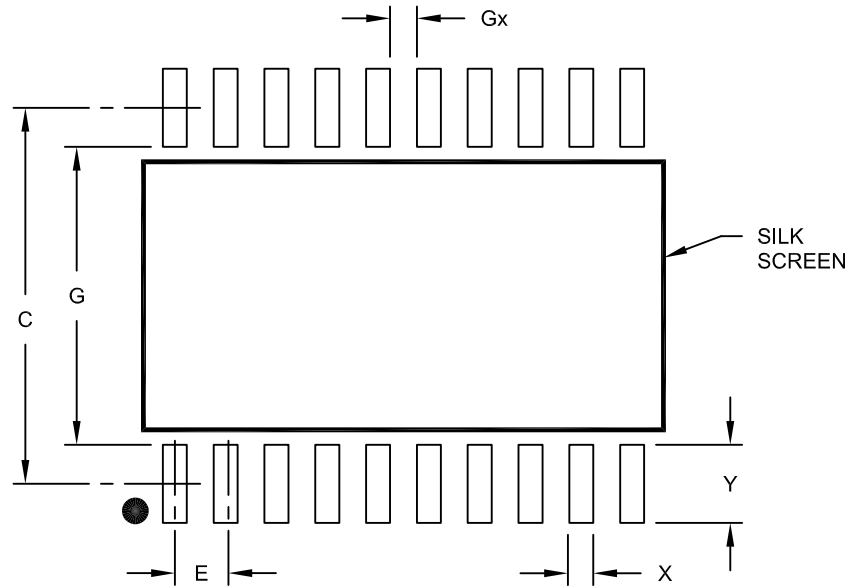
- Pin 1 visual index feature may vary, but must be located within the hatched area.
- § Significant Characteristic
- Dimension D does not include mold flash, protrusions or gate burrs, which shall not exceed 0.15 mm per end. Dimension E1 does not include interlead flash or protrusion, which shall not exceed 0.25 mm per side.
- Dimensioning and tolerancing per ASME Y14.5M  
BSC: Basic Dimension. Theoretically exact value shown without tolerances.  
REF: Reference Dimension, usually without tolerance, for information purposes only.
- Datums A & B to be determined at Datum H.

Microchip Technology Drawing No. C04-094C Sheet 2 of 2

# PIC16(L)F1764/5/8/9

20-Lead Plastic Small Outline (SO) - Wide, 7.50 mm Body [SOIC]

**Note:** For the most current package drawings, please see the Microchip Packaging Specification located at <http://www.microchip.com/packaging>



RECOMMENDED LAND PATTERN

Dimension Limits	Units	MILLIMETERS		
		MIN	NOM	MAX
Contact Pitch	E	1.27 BSC		
Contact Pad Spacing	C		9.40	
Contact Pad Width (X20)	X			0.60
Contact Pad Length (X20)	Y			1.95
Distance Between Pads	Gx	0.67		
Distance Between Pads	G	7.45		

Notes:

1. Dimensioning and tolerancing per ASME Y14.5M

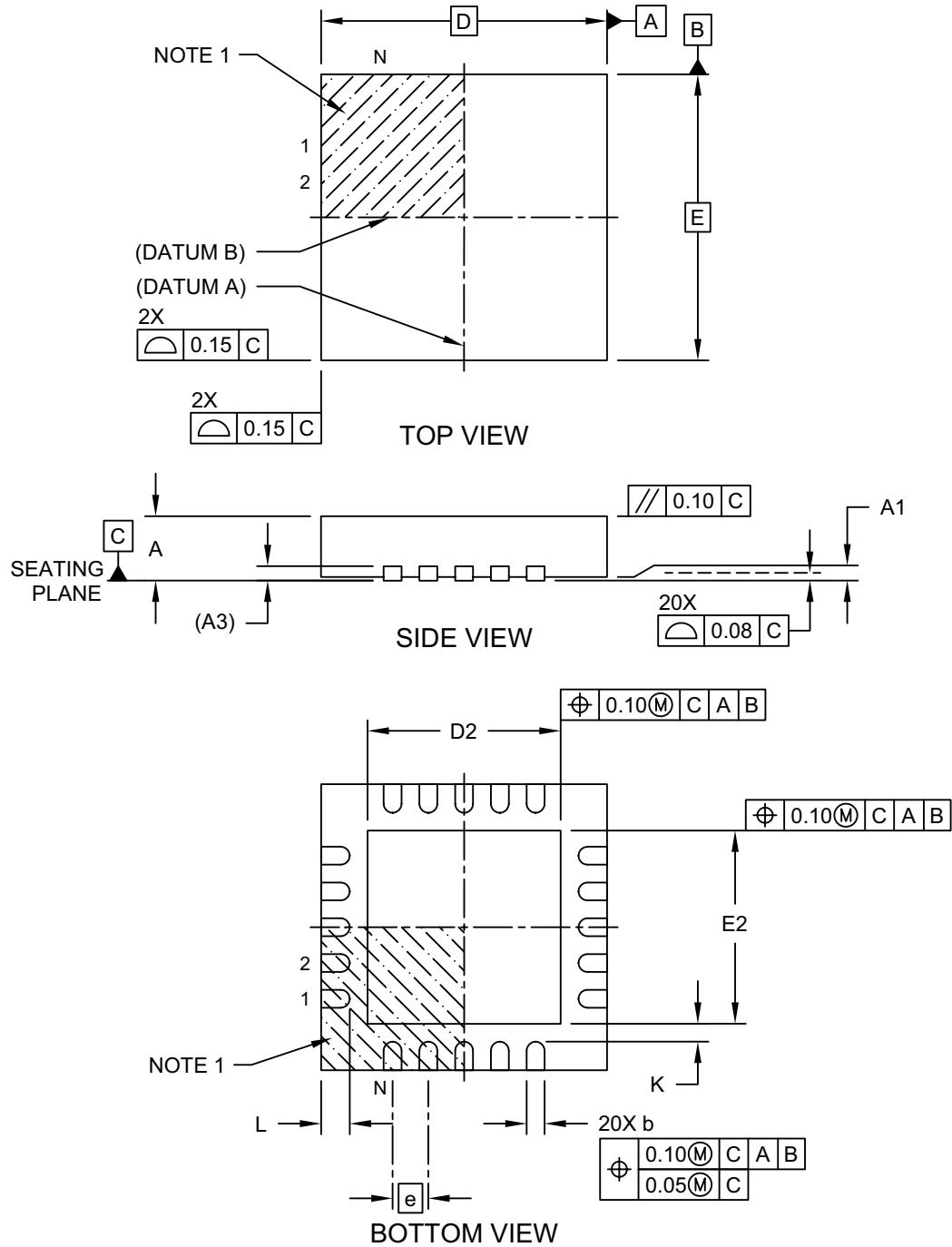
BSC: Basic Dimension. Theoretically exact value shown without tolerances.

Microchip Technology Drawing No. C04-2094A

# PIC16(L)F1764/5/8/9

## 20-Lead Plastic Quad Flat, No Lead Package (ML) - 4x4 mm Body [QFN] Also called VQFN

**Note:** For the most current package drawings, please see the Microchip Packaging Specification located at <http://www.microchip.com/packaging>



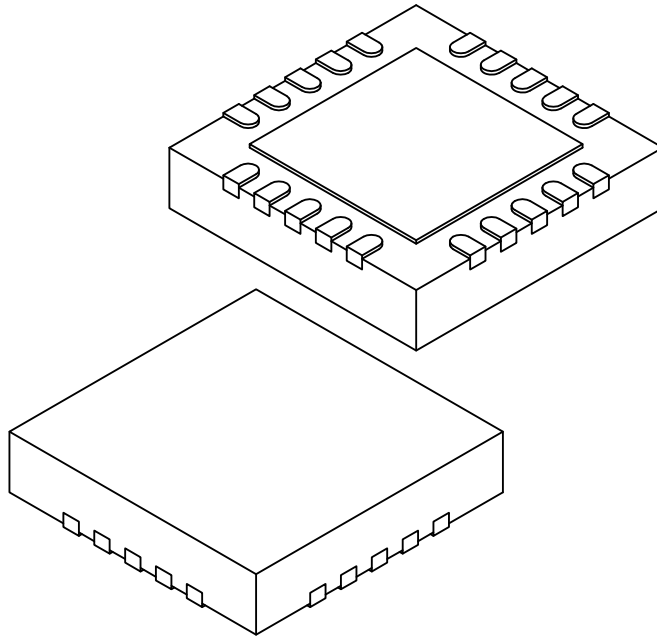
Microchip Technology Drawing C04-126 Rev C Sheet 1 of 2



# PIC16(L)F1764/5/8/9

## 20-Lead Plastic Quad Flat, No Lead Package (ML) - 4x4 mm Body [QFN] Also called VQFN

**Note:** For the most current package drawings, please see the Microchip Packaging Specification located at <http://www.microchip.com/packaging>



Dimension Limits	Units	MILLIMETERS		
		MIN	NOM	MAX
Number of Terminals	N	20		
Pitch	e	0.50 BSC		
Overall Height	A	0.80	0.90	1.00
Standoff	A1	0.00	0.02	0.05
Terminal Thickness	A3	0.20 REF		
Overall Length	D	4.00 BSC		
Exposed Pad Length	D2	2.60	2.70	2.80
Overall Width	E	4.00 BSC		
Exposed Pad Width	E2	2.60	2.70	2.80
Terminal Width	b	0.18	0.25	0.30
Terminal Length	L	0.30	0.40	0.50
Terminal-to-Exposed-Pad	K	0.20	-	-

**Notes:**

1. Pin 1 visual index feature may vary, but must be located within the hatched area.
2. Package is saw singulated
3. Dimensioning and tolerancing per ASME Y14.5M

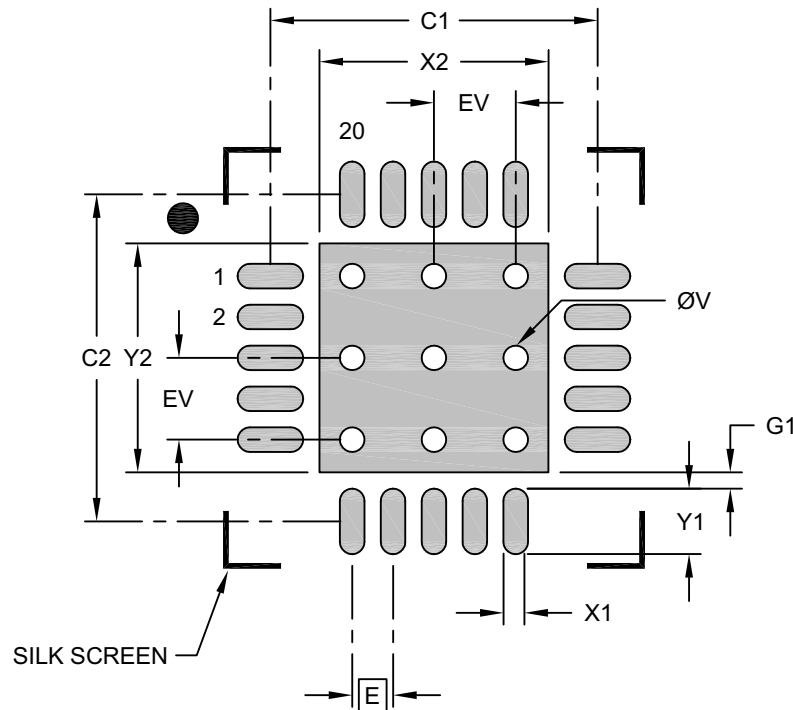
BSC: Basic Dimension. Theoretically exact value shown without tolerances.

REF: Reference Dimension, usually without tolerance, for information purposes only.

Microchip Technology Drawing C04-126 Rev C Sheet 2 of 2

## 20-Lead Plastic Quad Flat, No Lead Package (ML) - 4x4 mm Body [QFN] Also called VQFN

**Note:** For the most current package drawings, please see the Microchip Packaging Specification located at <http://www.microchip.com/packaging>



### RECOMMENDED LAND PATTERN

Dimension Limits	Units	MILLIMETERS		
		MIN	NOM	MAX
Contact Pitch	E	0.50 BSC		
Optional Center Pad Width	X2			2.80
Optional Center Pad Length	Y2			2.80
Contact Pad Spacing	C1		4.00	
Contact Pad Spacing	C2		4.00	
Contact Pad Width (X20)	X1			0.30
Contact Pad Length (X20)	Y1			0.80
Contact Pad to Center Pad (X16)	G1	0.20		
Thermal Via Diameter	V		0.30	
Thermal Via Pitch	EV		1.00	

#### Notes:

- Dimensioning and tolerancing per ASME Y14.5M  
BSC: Basic Dimension. Theoretically exact value shown without tolerances.
- For best soldering results, thermal vias, if used, should be filled or tented to avoid solder loss during reflow process

Microchip Technology Drawing C04-2126 Rev B

## APPENDIX A: DATA SHEET REVISION HISTORY

### Revision E (6/2019)

Added Registers 7-5 (PIE4) and 7-9 (PIR4).

Updated Register 7-3; Section 30.1; Tables 7-1, 8-1, 22-6, and 23-5.

Updated SOIC14L and QFN 20L packages.

### Revision D (3/2018)

Updated Equation 30-2; Figure 30-1; Register 30-4; and Table 3-16, 30-3 and 30-5.

### Revision C (3/2017)

Added Characterization Data.

Updated Equations 20-2 and 20-3; Example 16-1; Figure 24-2; Registers 27-11 and 32-4; Sections 16.1.3, 16.2.6, 20.5, 20.5.2, 23.1 and 27.9.1; Tables 3, 4, 1-2, 1-3, 3-12, 3-13, 3-16, 5-1, 12-1, 12-3, 32-4, 36-2, 36-17 and 36-22.

### Revision B (09/2015)

Added **Section 5.3.5 “Clock Switch Before Sleep”**.

Updated Cover page; Example 3-2; Figures 19-2, 31-2, 31-3, and 31-4; Registers 14-4, 16-3, 19-4, 24-2, 26-6, 27-4, 27-6, 27-8, 27-10, and 30-3; Sections 12.0, 12.2, 23.3.3, 23.6, 29.1 and 30.10; and Tables 1, 3, 4, 3-16, 5-1, 12-1, 16-1, 27-4, 28-1, 29-2, 30-2, 30-5, 36-2, 36-3, 36-8 and 36-11.

### Revision A (12/2014)

Initial release of this document.

## THE MICROCHIP WEBSITE

Microchip provides online support via our WWW site at [www.microchip.com](http://www.microchip.com). This website is used as a means to make files and information easily available to customers. Accessible by using your favorite Internet browser, the website contains the following information:

- **Product Support** – Data sheets and errata, application notes and sample programs, design resources, user's guides and hardware support documents, latest software releases and archived software
- **General Technical Support** – Frequently Asked Questions (FAQ), technical support requests, online discussion groups, Microchip consultant program member listing
- **Business of Microchip** – Product selector and ordering guides, latest Microchip press releases, listing of seminars and events, listings of Microchip sales offices, distributors and factory representatives

## CUSTOMER CHANGE NOTIFICATION SERVICE

Microchip's customer notification service helps keep customers current on Microchip products. Subscribers will receive e-mail notification whenever there are changes, updates, revisions or errata related to a specified product family or development tool of interest.

To register, access the Microchip website at [www.microchip.com](http://www.microchip.com). Under "Support", click on "Customer Change Notification" and follow the registration instructions.

## CUSTOMER SUPPORT

Users of Microchip products can receive assistance through several channels:

- Distributor or Representative
- Local Sales Office
- Field Application Engineer (FAE)
- Technical Support

Customers should contact their distributor, representative or Field Application Engineer (FAE) for support. Local sales offices are also available to help customers. A listing of sales offices and locations is included in the back of this document.

**Technical support is available through the website at: <http://microchip.com/support>**

NOTES:

## PRODUCT IDENTIFICATION SYSTEM

To order or obtain information, e.g., on pricing or delivery, refer to the factory or the listed sales office.

PART NO.	[X] <sup>(1)</sup>	-	X	/XX	XXX
Device	Tape and Reel Option		Temperature Range	Package	Pattern
<p><b>Device:</b> PIC16F1764, PIC16LF1764, PIC16F1765, PIC16LF1765, PIC16F1768, PIC16LF1768, PIC16F1769, PIC16LF1769</p>					
<p><b>Tape and Reel Option:</b> Blank = Standard packaging (tube or tray) T = Tape and Reel<sup>(1)</sup></p>					
<p><b>Temperature Range:</b> I = -40°C to +85°C (Industrial) E = -40°C to +125°C (Extended)</p>					
<p><b>Package:<sup>(2)</sup></b> ML = QFN P = PDIP SL = SOIC SO = SOIC SS = SSOP ST = TSSOP</p>					
<p><b>Pattern:</b> QTP, SQTP, Code or Special Requirements (blank otherwise)</p>					

**Examples:**

a) PIC16LF1764- I/P  
Industrial temperature  
PDIP package

b) PIC16F1769- E/SS  
Extended temperature,  
SSOP package

**Note 1:** Tape and Reel identifier only appears in the catalog part number description. This identifier is used for ordering purposes and is not printed on the device package. Check with your Microchip Sales Office for package availability with the Tape and Reel option.

**2:** Small form-factor packaging options may be available. Please check [www.microchip.com/packaging](http://www.microchip.com/packaging) for small-form factor package availability, or contact your local Sales Office.

---

---

**Note the following details of the code protection feature on Microchip devices:**

- Microchip products meet the specification contained in their particular Microchip Data Sheet.
- Microchip believes that its family of products is one of the most secure families of its kind on the market today, when used in the intended manner and under normal conditions.
- There are dishonest and possibly illegal methods used to breach the code protection feature. All of these methods, to our knowledge, require using the Microchip products in a manner outside the operating specifications contained in Microchip's Data Sheets. Most likely, the person doing so is engaged in theft of intellectual property.
- Microchip is willing to work with the customer who is concerned about the integrity of their code.
- Neither Microchip nor any other semiconductor manufacturer can guarantee the security of their code. Code protection does not mean that we are guaranteeing the product as “unbreakable.”

Code protection is constantly evolving. We at Microchip are committed to continuously improving the code protection features of our products. Attempts to break Microchip's code protection feature may be a violation of the Digital Millennium Copyright Act. If such acts allow unauthorized access to your software or other copyrighted work, you may have a right to sue for relief under that Act.

---

Information contained in this publication regarding device applications and the like is provided only for your convenience and may be superseded by updates. It is your responsibility to ensure that your application meets with your specifications. MICROCHIP MAKES NO REPRESENTATIONS OR WARRANTIES OF ANY KIND WHETHER EXPRESS OR IMPLIED, WRITTEN OR ORAL, STATUTORY OR OTHERWISE, RELATED TO THE INFORMATION, INCLUDING BUT NOT LIMITED TO ITS CONDITION, QUALITY, PERFORMANCE, MERCHANTABILITY OR FITNESS FOR PURPOSE. Microchip disclaims all liability arising from this information and its use. Use of Microchip devices in life support and/or safety applications is entirely at the buyer's risk, and the buyer agrees to defend, indemnify and hold harmless Microchip from any and all damages, claims, suits, or expenses resulting from such use. No licenses are conveyed, implicitly or otherwise, under any Microchip intellectual property rights unless otherwise stated.

### Trademarks

The Microchip name and logo, the Microchip logo, Adaptec, AnyRate, AVR, AVR logo, AVR Freaks, BesTime, BitCloud, chipKIT, chipKIT logo, CryptoMemory, CryptoRF, dsPIC, FlashFlex, flexPWR, HELDO, IGLOO, JukeBlox, KeeLoq, Klear, LANCheck, LinkMD, maXStylus, maXTouch, MediaLB, megaAVR, Microsemi, Microsemi logo, MOST, MOST logo, MPLAB, OptoLyzer, PackeTime, PIC, picoPower, PICSTART, PIC32 logo, PolarFire, Prochip Designer, QTouch, SAM-BA, SenGenuity, SpyNIC, SST, SST Logo, SuperFlash, Symmetricom, SyncServer, Tachyon, TempTracker, TimeSource, tinyAVR, UNI/O, Vectron, and XMEGA are registered trademarks of Microchip Technology Incorporated in the U.S.A. and other countries.

APT, ClockWorks, The Embedded Control Solutions Company, EtherSynch, FlashTec, Hyper Speed Control, HyperLight Load, IntelliMOS, Libero, motorBench, mTouch, Powermite 3, Precision Edge, ProASIC, ProASIC Plus, ProASIC Plus logo, Quiet-Wire, SmartFusion, SyncWorld, Temux, TimeCesium, TimeHub, TimePictra, TimeProvider, Vite, WinPath, and ZL are registered trademarks of Microchip Technology Incorporated in the U.S.A.

Adjacent Key Suppression, AKS, Analog-for-the-Digital Age, Any Capacitor, AnyIn, AnyOut, BlueSky, BodyCom, CodeGuard, CryptoAuthentication, CryptoAutomotive, CryptoCompanion, CryptoController, dsPICDEM, dsPICDEM.net, Dynamic Average Matching, DAM, ECAN, EtherGREEN, In-Circuit Serial Programming, ICSP, INICnet, Inter-Chip Connectivity, JitterBlocker, KlearNet, KlearNet logo, memBrain, Mindi, MiWi, MPASM, MPF, MPLAB Certified logo, MPLIB, MPLINK, MultiTRAK, NetDetach, Omniscient Code Generation, PICDEM, PICDEM.net, PICKit, PICtail, PowerSmart, PureSilicon, QMatrix, REAL ICE, Ripple Blocker, SAM-ICE, Serial Quad I/O, SMART-I.S., SQI, SuperSwitcher, SuperSwitcher II, Total Endurance, TSHARC, USBCheck, VariSense, ViewSpan, WiperLock, Wireless DNA, and ZENA are trademarks of Microchip Technology Incorporated in the U.S.A. and other countries.

SQTP is a service mark of Microchip Technology Incorporated in the U.S.A.

The Adaptec logo, Frequency on Demand, Silicon Storage Technology, and Symmcom are registered trademarks of Microchip Technology Inc. in other countries.

GestIC is a registered trademark of Microchip Technology Germany II GmbH & Co. KG, a subsidiary of Microchip Technology Inc., in other countries.

All other trademarks mentioned herein are property of their respective companies.

© 2014-2019, Microchip Technology Incorporated, All Rights Reserved.

ISBN: 978-1-5224-4679-8

For information regarding Microchip's Quality Management Systems, please visit [www.microchip.com/quality](http://www.microchip.com/quality).



# MICROCHIP

## Worldwide Sales and Service

### AMERICAS

**Corporate Office**  
2355 West Chandler Blvd.  
Chandler, AZ 85224-6199  
Tel: 480-792-7200  
Fax: 480-792-7277  
Technical Support:  
<http://www.microchip.com/support>  
Web Address:  
[www.microchip.com](http://www.microchip.com)

#### Atlanta

Duluth, GA  
Tel: 678-957-9614  
Fax: 678-957-1455

#### Austin, TX

Tel: 512-257-3370

#### Boston

Westborough, MA  
Tel: 774-760-0087  
Fax: 774-760-0088

#### Chicago

Itasca, IL  
Tel: 630-285-0071  
Fax: 630-285-0075

#### Dallas

Addison, TX  
Tel: 972-818-7423  
Fax: 972-818-2924

#### Detroit

Novi, MI  
Tel: 248-848-4000

#### Houston, TX

Tel: 281-894-5983

#### Indianapolis

Noblesville, IN  
Tel: 317-773-8323  
Fax: 317-773-5453  
Tel: 317-536-2380

#### Los Angeles

Mission Viejo, CA  
Tel: 949-462-9523  
Fax: 949-462-9608  
Tel: 951-273-7800

#### Raleigh, NC

Tel: 919-844-7510

#### New York, NY

Tel: 631-435-6000

#### San Jose, CA

Tel: 408-735-9110  
Tel: 408-436-4270

#### Canada - Toronto

Tel: 905-695-1980  
Fax: 905-695-2078

### ASIA/PACIFIC

**Australia - Sydney**  
Tel: 61-2-9868-6733

**China - Beijing**  
Tel: 86-10-8569-7000

**China - Chengdu**  
Tel: 86-28-8665-5511

**China - Chongqing**  
Tel: 86-23-8980-9588

**China - Dongguan**  
Tel: 86-769-8702-9880

**China - Guangzhou**  
Tel: 86-20-8755-8029

**China - Hangzhou**  
Tel: 86-571-8792-8115

**China - Hong Kong SAR**  
Tel: 852-2943-5100

**China - Nanjing**  
Tel: 86-25-8473-2460

**China - Qingdao**  
Tel: 86-532-8502-7355

**China - Shanghai**  
Tel: 86-21-3326-8000

**China - Shenyang**  
Tel: 86-24-2334-2829

**China - Shenzhen**  
Tel: 86-755-8864-2200

**China - Suzhou**  
Tel: 86-186-6233-1526

**China - Wuhan**  
Tel: 86-27-5980-5300

**China - Xian**  
Tel: 86-29-8833-7252

**China - Xiamen**  
Tel: 86-592-2388138

**China - Zhuhai**  
Tel: 86-756-3210040

### ASIA/PACIFIC

**India - Bangalore**  
Tel: 91-80-3090-4444

**India - New Delhi**  
Tel: 91-11-4160-8631

**India - Pune**  
Tel: 91-20-4121-0141

**Japan - Osaka**  
Tel: 81-6-6152-7160

**Japan - Tokyo**  
Tel: 81-3-6880-3770

**Korea - Daegu**  
Tel: 82-53-744-4301

**Korea - Seoul**  
Tel: 82-2-554-7200

**Malaysia - Kuala Lumpur**  
Tel: 60-3-7651-7906

**Malaysia - Penang**  
Tel: 60-4-227-8870

**Philippines - Manila**  
Tel: 63-2-634-9065

**Singapore**  
Tel: 65-6334-8870

**Taiwan - Hsin Chu**  
Tel: 886-3-577-8366

**Taiwan - Kaohsiung**  
Tel: 886-7-213-7830

**Taiwan - Taipei**  
Tel: 886-2-2508-8600

**Thailand - Bangkok**  
Tel: 66-2-694-1351

**Vietnam - Ho Chi Minh**  
Tel: 84-28-5448-2100

### EUROPE

**Austria - Wels**  
Tel: 43-7242-2244-39  
Fax: 43-7242-2244-393

**Denmark - Copenhagen**  
Tel: 45-4450-2828  
Fax: 45-4485-2829

**Finland - Espoo**  
Tel: 358-9-4520-820

**France - Paris**  
Tel: 33-1-69-53-63-20  
Fax: 33-1-69-30-90-79

**Germany - Garching**  
Tel: 49-8931-9700

**Germany - Haan**  
Tel: 49-2129-3766400

**Germany - Heilbronn**  
Tel: 49-7131-72400

**Germany - Karlsruhe**  
Tel: 49-721-625370

**Germany - Munich**  
Tel: 49-89-627-144-0  
Fax: 49-89-627-144-44

**Germany - Rosenheim**  
Tel: 49-8031-354-560

**Israel - Ra'anana**  
Tel: 972-9-744-7705

**Italy - Milan**  
Tel: 39-0331-742611  
Fax: 39-0331-466781

**Italy - Padova**  
Tel: 39-049-7625286

**Netherlands - Drunen**  
Tel: 31-416-690399  
Fax: 31-416-690340

**Norway - Trondheim**  
Tel: 47-7288-4388

**Poland - Warsaw**  
Tel: 48-22-3325737

**Romania - Bucharest**  
Tel: 40-21-407-87-50

**Spain - Madrid**  
Tel: 34-91-708-08-90  
Fax: 34-91-708-08-91

**Sweden - Gothenberg**  
Tel: 46-31-704-60-40

**Sweden - Stockholm**  
Tel: 46-8-5090-4654

**UK - Wokingham**  
Tel: 44-118-921-5800  
Fax: 44-118-921-5820