

QUARTZ CRYSTAL, SERIES TG5

Glass Sealed Ceramic 5.0 x 3.2mm SMD

FEATURE

- Ultra thin, thickness 1.0mm
- Leadless type
- High precision characteristic covering up to high frequency range
- Automatic mounting
- Emboss taping specification
- Suitable for Reflow soldering
- Ideally suited designed for disc drives, NB, PCs and hand-held electronic products

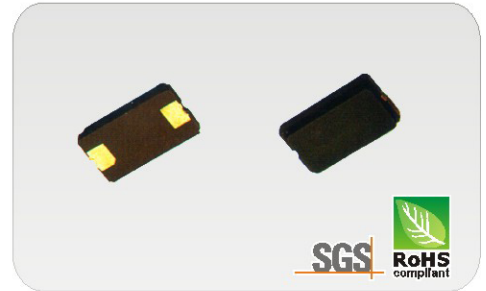

ELECTRICAL SPECIFICATIONS

Item	Specifications
Frequency Range	8.000 MHz to 54.000 MHz
Load Capacitance(C _L)	Series, 16pF, 20pF, 30pF, 32pF, or specify
Frequency Tolerance (at 25°C)	± 10ppm ~ ± 50ppm or specify
Operating Temperature Range	-10°C—+60°C (standard), -20°C—+70°C, -40°C—+85°C, or Specify
Frequency Stability Over Operating Temperature Range	± 10ppm~ ± 50ppm or specify
Storage Temperature Range	-55°C to + 125 °C
Shunt Capacitance (C ₀)	5.0 pF Max
Drive Level	10 μ W~100 μ W
Aging @25° C 1 st year (Max)	± 3ppm, ± 5ppm/year
Shock Resistance	Drop test of 3 times on 2mm stainless plate from 75cm height

*Please consult our sales representative for other specifications.

EQUIVALENT SERIES RESISTANCE (ESR) AND OSCILLATION MODE

Frequency Range	E.S.R. (Ω)	Mode
8.000 MHz ~ 30.000MHz	60 Max	Fundamental/AT
30.000 MHz ~ 54.000MHz	45 Max	Fundamental/AT

DIMENSION(mm)

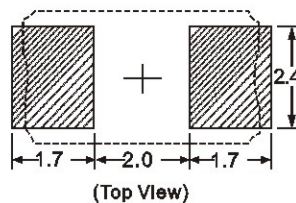
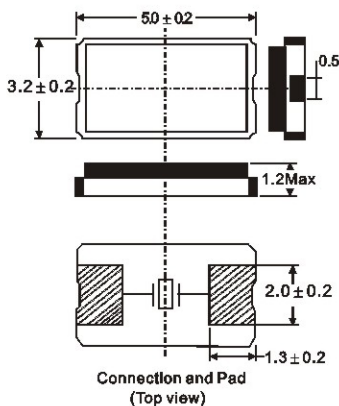

REFLOW CONDITION

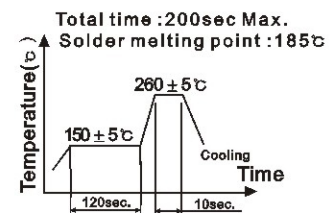

PACKING SPECIFICATION(mm)

