

## P/N:WTL9S11444

### Resistance Welded HC-49/S Low Profile Package



#### FEATURE

- Standard height 3.5mm, the part is compact at about one-fourth of the HC-49/U package
- A resistance weld completely sealed type
- Good stability and high reliability
- Copes with high density mounting and is the optimum for mass production



#### ELECTRICAL SPECIFICATIONS

Nominal frequency	13.400078MHz
Oscillation mode	See below table
Operating temperature range	-10°C--+60°C
Storage temperature range	-40°C--+85°C
Frequency tolerance	±30ppm
Freq. Temp characteristics	±30ppm
Load capacitance	20 pF
Equivalent series resistance	See below table
Parallel capacitance(Co)	7PF Max
Drive level	100 μW Typical
Insulation resistance	More than 500M Ω AT DC100V

#### EQUIVALENT SERIES RESISTANCE(ESR) AND OSCILLATION MODE

Frequency Range	E.S.R (Ω)	Mode	Frequency Range	E.S.R (Ω)	Mode
3.000MHz~5.999MHz	150Max	Fundamental/AT	24.000MHz~40.320MHz	30Max	Fundamental/ BT
6.000MHz~7.999MHz	60Max	Fundamental/AT	24.000MHz~29.999MHz	100Max	Third Overtone /AT
8.000MHz~15.999MHz	50Max	Fundamental/AT	30.000MHz~49.999MHz	80Max	Third Overtone /AT
16.000MHz~30.000MHz	30Max	Fundamental/AT	50.000MHz~100.000MHz	60Max	Third Overtone /AT

**P/N:WTL9S11444**

**Resistance Welded HC-49/S Low Profile Package**



**Dimension**

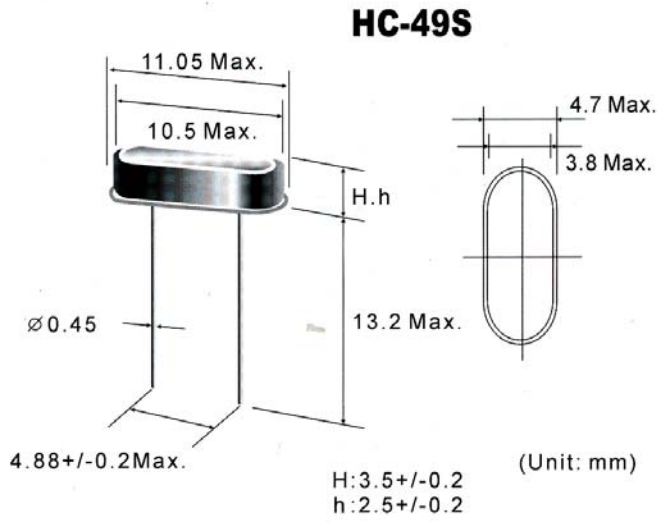

*h*