

# GSM Antenna AN110

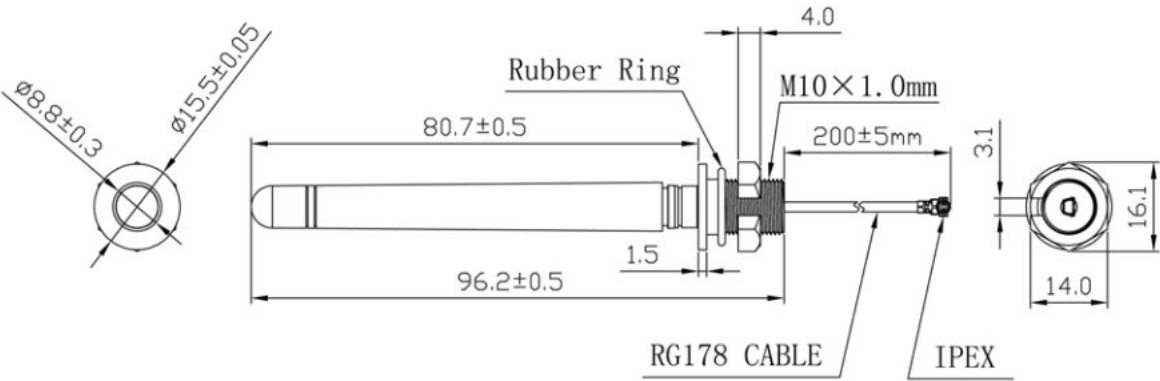

## DIMENSIONS



Unit: mm

## SPECIFICATIONS

Item		Specifications
Antenna	Frequency Range	880~960/1710~2170MHz
	Polarization	Linear
	Gain	2dBi (Zenith)
	V.S.W.R (min)	<2.0
	Impedance	50 $\Omega$
Mechanical	Cable	RG178
	Connector	IPEX or others
	Mounting Method	Screw
Environmental	Operating Temperature	-40°C~+85°C
	Relative Humidity	Up to 95%
	Vibration	10 to 55Hz with 1.5mm amplitude 2hours
	Environmentally Friendly	ROHS Compliant