

NPN SILICON PLANAR EPITAXIAL TRANSISTOR

**BC368
TO-92
BCE**

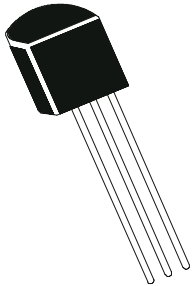

Transistor in TO-92 Plastic Package Intended for Low Voltage, High Current LF Applications, Suitable for Class-B Audio Output Stages up to 3W

ABSOLUTE MAXIMUM RATINGS

DESCRIPTION	SYMBOL	VALUE	UNIT
Collector -Emitter Voltage	VCES	25	V
Collector -Emitter Voltage	VCEO	20	V
Emitter- Base Voltage	VEBO	5.0	V
Collector- Current	IC	1.0	A
Collector- Current Peak Value	ICM	2.0	A
Base- Current	IB	100	mA
Base- Current Peak Value	IBM	200	mA
Power Dissipation @ Ta=25 deg C	PTA	0.8	W
@ Tc=25 deg C	PTC	1.0	W
Junction Temperature	Tj	150	deg C
Storage Temperature Range	Tstg	-65 to +150	deg C
Thermal Resistance			
Junction to Ambient in Free Air	Rth (j-a)	156	deg C/W
Junction to Ambient *	Rth (j-a)	125	deg C/W
Junction to Case	Rth (j-c)	60	deg C/W

*Mounted on printed-circuit board , maximum lead length 4mm, mounting pad for collector lead min 10 mm x10 mm

ELECTRICAL CHARACTERISTICS (Ta=25 deg C Unless Otherwise Specified)

DESCRIPTION	SYMBOL	TEST CONDITION	MIN	TYP	MAX	UNIT
Collector Cut- off Current	ICBO	IE=0, VCB=25V	-	-	10	uA
		Tj=150 deg C IE=0, VCB=25V	-	-	1.0	mA
Emitter Cut- off Current	IEBO	VEB=5V, IC=0	-	-	10	uA
Base- Emitter on Voltage	VBE(on)	IC=5mA, VCE=10V	-	-	0.7	V
		IC=1A, VCE=1V	-	-	1.0	V
Collector- Emitter Saturation Voltage	VCE(Sat)	IC=1A, IB=100mA	-	-	0.5	V

ELECTRICAL CHARACTERISTICS (Ta=25 deg C Unless Otherwise Specified)

DESCRIPTION	SYMBOL	TEST CONDITION	MIN	TYP	MAX	UNIT
DC Current Gain	hFE	IC=5mA, VCE=10V	50	-	-	
		IC=500mA, VCE=1V	85	-	375	
	hFE Group	IC=500mA, VCE=1V				
		-10	63		160	
		-16	100		250	
		-25	160		400	
		IC=1A, VCE=1V	60		-	

DYNAMIC CHARACTERISTICS

Collector Capacitance	Cc	IE=0, VCB=5V, f=450kHz	-	-	40	pF
Transition frequency	ft	IC=10mA, VCE=5V, f=35MHZ	40	-	-	MHz

TO-92 Plastic Package

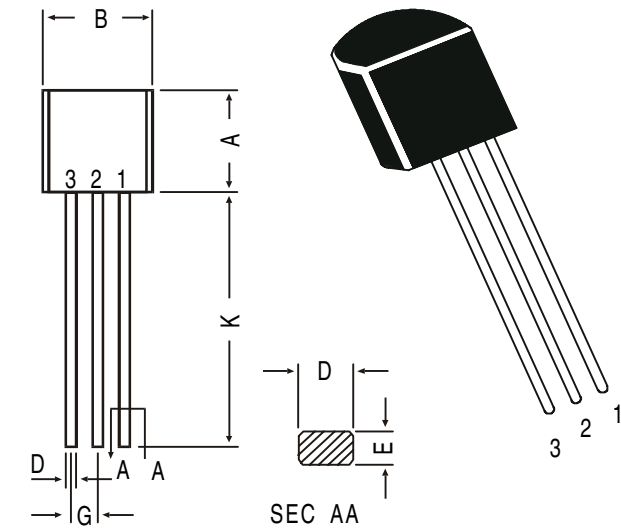

SEC AA

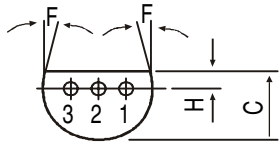

- PIN CONFIGURATION**
1. BASE
 2. COLLECTOR
 3. EMITTER

All dimensions in mm.

DIM	MIN.	MAX.
A	4.32	5.33
B	4.45	5.20
C	3.18	4.19
D	0.41	0.55
E	0.35	0.50
F	5 DEG	
G	1.14	1.40
H	1.14	1.53
K	12.70	—

TO-92 Transistors on Tape and Ammo Pack

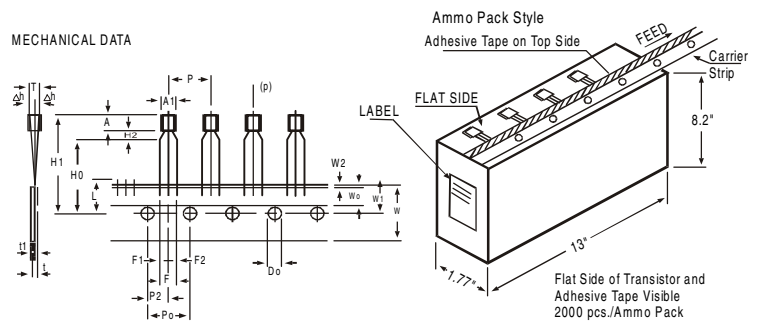

All dimensions in mm unless specified otherwise

ITEM	SYMBOL	SPECIFICATION			REMARKS
		MIN.	NOM.	MAX.	
BODY WIDTH	A1	4.0		4.8	
BODY HEIGHT	A	4.8		5.2	
BODY THICKNESS	T	3.9		4.2	
PITCH OF COMPONENT	P		12.7		±1
FEED HOLE PITCH	Po		12.7		±0.3
FEED HOLE CENTRE TO COMPONENT CENTRE	P2		6.35		±0.4
DISTANCE BETWEEN OUTER LEADS	F		5.08		+0.6 -0.2
COMPONENT ALIGNMENT	Δh		0	1	AT TOP OF BODY
TAPE WIDTH	W		18		±0.5
HOLD-DOWN TAPE WIDTH	W0		6		±0.2
HOLE POSITION	W1		9		+0.7 -0.5
HOLD-DOWN TAPE POSITION	W2		0.5		±0.2
LEAD WIRE CLINCH HEIGHT	Ho		16		±0.5
COMPONENT HEIGHT	H1			23.25	
LENGTH OF SNIPPED LEADS	L			11.0	
FEED HOLE DIAMETER	Do		4		±0.2
TOTAL TAPE THICKNESS	t			1.2	t1 0.3 - 0.6
LEAD - TO - LEAD DISTANCE F1,	F2		2.54		+0.4 -0.1
CLINCH HEIGHT	H2			3	
PULL - OUT FORCE	(P)	6N			

NOTES

1. MAXIMUM ALIGNMENT DEVIATION BETWEEN LEADS NOT TO BE GREATER THAN 0.2 mm.
2. MAXIMUM NON-CUMULATIVE VARIATION BETWEEN TAPE FEED HOLES SHALL NOT EXCEED 1 mm IN 20 PITCHES.
3. HOLDDOWN TAPE NOT TO EXCEED BEYOND THE EDGE(S) OF CARRIER TAPE AND THERE SHALL BE NO EXPOSURE OF ADHESIVE.
4. NO MORE THAN 3 CONSECUTIVE MISSING COMPONENTS ARE PERMITTED.
5. A TAPE TRAILER, HAVING AT LEAST THREE FEED HOLES ARE REQUIRED AFTER THE LAST COMPONENT.
6. SPLICES SHALL NOT INTERFERE WITH THE SPROCKET FEED HOLES.

Packing Detail

PACKAGE	STANDARD PACK		INNER CARTON BOX		OUTER CARTON BOX		
	Details	Net Weight/Qty	Size	Qty	Size	Qty	Gr Wt
TO-92 Bulk	1K/polybag	200 gm/1K pcs	3" x 7.5" x 7.5"	5.0K	17" x 15" x 13.5"	80.0K	23 kgs
TO-92 T&A	2K/ammo box	645 gm/2K pcs	12.5" x 8" x 1.8"	2.0K	17" x 15" x 13.5"	32.0K	12.5 kgs

Notes

Disclaimer

The product information and the selection guides facilitate selection of the CDIL's Discrete Semiconductor Device(s) best suited for application in your product(s) as per your requirement. It is recommended that you completely review our Data Sheet(s) so as to confirm that the Device(s) meet functionality parameters for your application. The information furnished on the CDIL Web Site/CD is believed to be accurate and reliable. CDIL however, does not assume responsibility for inaccuracies or incomplete information. Furthermore, CDIL does not assume liability whatsoever, arising out of the application or use of any CDIL product; neither does it convey any license under its patent rights nor rights of others. These products are not designed for use in life saving/support appliances or systems. CDIL customers selling these products (either as individual Discrete Semiconductor Devices or incorporated in their end products), in any life saving/support appliances or systems or applications do so at their own risk and CDIL will not be responsible for any damages resulting from such sale(s).

CDIL strives for continuous improvement and reserves the right to change the specifications of its products without prior notice.



CDIL is a registered Trademark of

Continental Device India Limited

C-120 Naraina Industrial Area, New Delhi 110 028, India.

Telephone + 91-11-579 6150 Fax + 91-11-579 9569, 579 5290

e-mail sales@cdil.com www.cdil.com