

isc Silicon NPN Power Transistor

BUT12AF

DESCRIPTION

- High Voltage
- High Speed Switching

APPLICATIONS

- Converters
- Inverters
- Switching regulators
- Motor control systems

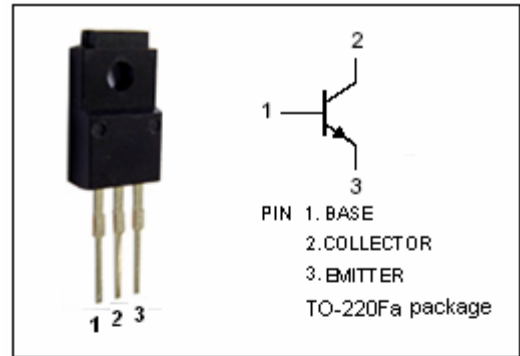

ABSOLUTE MAXIMUM RATINGS (T_a=25°C)

SYMBOL	PARAMETER	VALUE	UNIT
V _{CB0}	Collector-Base Voltage	1000	V
V _{CEO}	Collector-Emitter Voltage	450	V
V _{EBO}	Emitter-Base Voltage	9	V
I _C	Collector Current-Continuous	8	A
I _{CM}	Collector Current-Peak	20	A
I _B	Base Current-Continuous	4	A
I _{BM}	Base Current-peak	6	A
P _C	Collector Power Dissipation @T _C =25°C	23	W
T _j	Junction Temperature	150	°C
T _{stg}	Storage Temperature Range	-65~150	°C

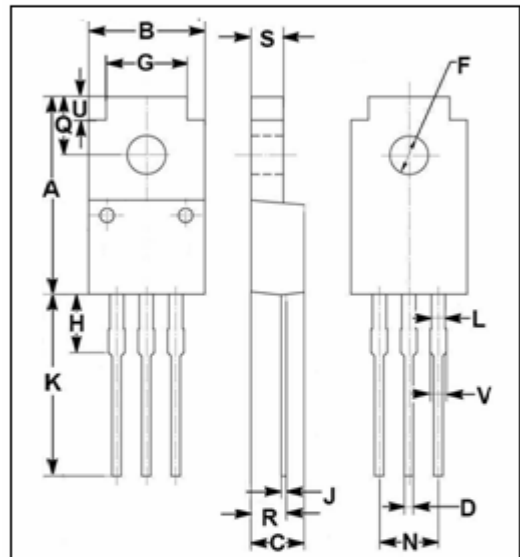

DIM	mm	
	MIN	MAX
A	16.85	17.15
B	9.90	10.10
C	4.35	4.65
D	0.75	0.80
F	3.20	3.40
G	6.90	7.10
H	5.15	5.45
J	0.45	0.75
K	13.35	13.65
L	1.10	1.30
N	4.98	5.18
Q	4.85	5.15
R	2.95	3.25
S	2.70	2.90
U	1.75	2.05
V	1.30	1.50

THERMAL CHARACTERISTICS

SYMBOL	PARAMETER	MAX	UNIT
R _{th j-a}	Thermal Resistance, Junction to Ambient	5.5	K/W

isc Silicon NPN Power Transistor**BUT12AF****ELECTRICAL CHARACTERISTICS** $T_C=25^{\circ}\text{C}$ unless otherwise specified

SYMBOL	PARAMETER	CONDITIONS	MIN	TYP.	MAX	UNIT
$V_{CEO(SUS)}$	Collector-Emitter Sustaining Voltage	$I_C=0.1\text{A}; I_B=0; L=25\text{mH}$	450			V
$V_{CE(sat)}$	Collector-Emitter Saturation Voltage	$I_C=5\text{A}; I_B=1\text{A}$			1.5	V
$V_{BE(sat)}$	Base-Emitter Saturation Voltage	$I_C=5\text{A}; I_B=1\text{A}$			1.5	V
I_{CES}	Collector Cutoff Current	$V_{CE}=1000\text{V}; V_{BE}=0$ $V_{CE}=1000\text{V}; V_{BE}=0; T_j=125^{\circ}\text{C}$			1.0 3.0	mA
I_{EBO}	Emitter Cutoff Current	$V_{EB}=9\text{V}; I_C=0$			10	mA
h_{FE-1}	DC Current Gain	$I_C=10\text{mA}; V_{CE}=5\text{V}$	10		35	
h_{FE-2}	DC Current Gain	$I_C=1\text{A}; V_{CE}=5\text{V}$	10		35	

Switching Times; Resistive Load

t_{on}	Turn-on Time	$I_C=5\text{A}; I_{B1}=-I_{B2}=1\text{A};$ $V_{CC}=250\text{V}$			1	μs
t_s	Storage Time				4	μs
t_f	Fall Time				0.8	μs

isc Silicon NPN Power Transistor

BUT12AF

