

LAN8740A/LAN8740Ai



Small Footprint MII/RMII 10/100 Energy Efficient Ethernet Transceiver with HP Auto-MDIX and flexPWR[®] Technology

PRODUCT FEATURES

Datasheet

Highlights

- Single-Chip Ethernet Physical Layer Transceiver (PHY)
- Compliant with Energy Efficient Ethernet 802.3az
- Cable diagnostic support
- Wake on LAN (WoL) support
- Comprehensive flexPWR[®] technology
 - Flexible power management architecture
 - LVCMOS Variable I/O voltage range: +1.8 V to +3.3 V
 - Integrated 1.2 V regulator with disable feature
- HP Auto-MDIX support
- Small footprint 32-pin SQFN lead-free RoHS compliant package (5 x 5 x 0.9 mm height)
- Deterministic 100 Mb internal loopback latency (MII Mode)

Target Applications

- Set-Top Boxes
- Networked Printers and Servers
- Test Instrumentation
- LAN on Motherboard
- Embedded Telecom Applications
- Video Record/Playback Systems
- Cable Modems/Routers
- DSL Modems/Routers
- Digital Video Recorders
- IP and Video Phones
- Wireless Access Points
- Digital Televisions
- Digital Media Adaptors/Servers
- Gaming Consoles
- POE Applications (Refer to SMSC Application Note 17.18)

Key Benefits

- High-performance 10/100 Ethernet transceiver
 - Compliant with IEEE802.3/802.3u (Fast Ethernet)
 - Compliant with ISO 802-3/IEEE 802.3 (10BASE-T)
 - Compliant with Energy Efficient Ethernet IEEE 802.3az
 - Loop-back modes
 - Auto-negotiation
 - Automatic polarity detection and correction
 - Link status change wake-up detection
 - Vendor specific register functions
 - Supports both MII and the reduced pin count RMII interfaces
- Power and I/Os
 - Various low power modes
 - Integrated power-on reset circuit
 - Two status LED outputs
 - May be used with a single 3.3 V supply
- Additional Features
 - Ability to use a low cost 25 MHz crystal for reduced BOM
- Packaging
 - 32-pin SQFN (5 x 5 mm) lead-free RoHS compliant package with MII and RMII
- Environmental
 - Commercial temperature range (0°C to +70°C)
 - Industrial temperature range (-40°C to +85°C)

Datasheet

ORDER NUMBER(S):

LAN8740A-EN (Tray) for 32-pin, SQFN lead-free RoHS compliant package (0°C to +70°C temp)
LAN8740Ai-EN (Tray) for 32-pin, SQFN lead-free RoHS compliant package (-40°C to +85°C temp)
LAN8740A-EN-TR (Tape & Reel) for 32-pin, SQFN lead-free RoHS compliant package (0°C to +70°C temp)
LAN8740Ai-EN-TR (Tape & Reel) for 32-pin, SQFN lead-free RoHS compliant package (-40 to +85°C temp)

This product meets the halogen maximum concentration values per IEC61249-2-21
For RoHS compliance and environmental information, please visit www.smSC.com/rohs

Please contact your SMSC sales representative for additional documentation related to this product such as application notes, anomaly sheets, and design guidelines.

Copyright © 2013 SMSC or its subsidiaries. All rights reserved.

Circuit diagrams and other information relating to SMSC products are included as a means of illustrating typical applications. Consequently, complete information sufficient for construction purposes is not necessarily given. Although the information has been checked and is believed to be accurate, no responsibility is assumed for inaccuracies. SMSC reserves the right to make changes to specifications and product descriptions at any time without notice. Contact your local SMSC sales office to obtain the latest specifications before placing your product order. The provision of this information does not convey to the purchaser of the described semiconductor devices any licenses under any patent rights or other intellectual property rights of SMSC or others. All sales are expressly conditional on your agreement to the terms and conditions of the most recently dated version of SMSC's standard Terms of Sale Agreement dated before the date of your order (the "Terms of Sale Agreement"). The product may contain design defects or errors known as anomalies which may cause the product's functions to deviate from published specifications. Anomaly sheets are available upon request. SMSC products are not designed, intended, authorized or warranted for use in any life support or other application where product failure could cause or contribute to personal injury or severe property damage. Any and all such uses without prior written approval of an Officer of SMSC and further testing and/or modification will be fully at the risk of the customer. Copies of this document or other SMSC literature, as well as the Terms of Sale Agreement, may be obtained by visiting SMSC's website at <http://www.smSC.com>. SMSC is a registered trademark of Standard Microsystems Corporation ("SMSC"). Product names and company names are the trademarks of their respective holders.

The Microchip name and logo, and the Microchip logo are registered trademarks of Microchip Technology Incorporated in the U.S.A. and other countries.

SMSC DISCLAIMS AND EXCLUDES ANY AND ALL WARRANTIES, INCLUDING WITHOUT LIMITATION ANY AND ALL IMPLIED WARRANTIES OF MERCHANTABILITY, FITNESS FOR A PARTICULAR PURPOSE, TITLE, AND AGAINST INFRINGEMENT AND THE LIKE, AND ANY AND ALL WARRANTIES ARISING FROM ANY COURSE OF DEALING OR USAGE OF TRADE. IN NO EVENT SHALL SMSC BE LIABLE FOR ANY DIRECT, INCIDENTAL, INDIRECT, SPECIAL, PUNITIVE, OR CONSEQUENTIAL DAMAGES; OR FOR LOST DATA, PROFITS, SAVINGS OR REVENUES OF ANY KIND; REGARDLESS OF THE FORM OF ACTION, WHETHER BASED ON CONTRACT; TORT; NEGLIGENCE OF SMSC OR OTHERS; STRICT LIABILITY; BREACH OF WARRANTY; OR OTHERWISE; WHETHER OR NOT ANY REMEDY OF BUYER IS HELD TO HAVE FAILED OF ITS ESSENTIAL PURPOSE, AND WHETHER OR NOT SMSC HAS BEEN ADVISED OF THE POSSIBILITY OF SUCH DAMAGES.

Table of Contents

| | |
|---|-----------|
| Chapter 1 Introduction | 8 |
| 1.1 General Terms and Conventions | 8 |
| 1.2 General Description | 8 |
| Chapter 2 Pin Description and Configuration | 10 |
| 2.1 Pin Assignments | 19 |
| 2.2 Buffer Types | 20 |
| Chapter 3 Functional Description | 21 |
| 3.1 Transceiver | 21 |
| 3.1.1 100BASE-TX Transmit | 21 |
| 3.1.2 100BASE-TX Receive | 24 |
| 3.1.3 10BASE-T Transmit | 27 |
| 3.1.4 10BASE-T Receive | 27 |
| 3.2 Auto-Negotiation | 28 |
| 3.2.1 Parallel Detection | 30 |
| 3.2.2 Restarting Auto-Negotiation | 30 |
| 3.2.3 Disabling Auto-Negotiation | 30 |
| 3.2.4 Half vs. Full Duplex | 30 |
| 3.3 HP Auto-MDIX Support | 31 |
| 3.4 MAC Interface | 31 |
| 3.4.1 MII | 32 |
| 3.4.2 RMII | 32 |
| 3.4.3 MII vs. RMII Configuration | 34 |
| 3.5 Serial Management Interface (SMI) | 35 |
| 3.6 Interrupt Management | 36 |
| 3.6.1 Primary Interrupt System | 37 |
| 3.6.2 Alternate Interrupt System | 38 |
| 3.7 Configuration Straps | 39 |
| 3.7.1 PHYAD[2:0]: PHY Address Configuration | 39 |
| 3.7.2 MODE[2:0]: Mode Configuration | 40 |
| 3.7.3 RMIISEL: MII/RMII Mode Configuration | 41 |
| 3.7.4 REGOFF: Internal +1.2 V Regulator Configuration | 41 |
| 3.7.5 nINTSEL: nINT/TXER/TXD4 Configuration | 42 |
| 3.8 Miscellaneous Functions | 43 |
| 3.8.1 LEDs | 43 |
| 3.8.2 Variable Voltage I/O | 47 |
| 3.8.3 Power-Down Modes | 47 |
| 3.8.4 Wake on LAN (WoL) | 48 |
| 3.8.5 Energy Efficient Ethernet | 54 |
| 3.8.6 Isolate Mode | 54 |
| 3.8.7 Resets | 54 |
| 3.8.8 Carrier Sense | 55 |
| 3.8.9 Collision Detect | 55 |
| 3.8.10 Link Integrity Test | 55 |
| 3.8.11 Cable Diagnostics | 56 |
| 3.8.12 Loopback Operation | 61 |
| 3.9 Application Diagrams | 63 |

Datasheet

| | | |
|------------------|---|-----------|
| 3.9.1 | Simplified System Level Application Diagram | 63 |
| 3.9.2 | Power Supply Diagram (1.2 V Supplied by Internal Regulator) | 64 |
| 3.9.3 | Power Supply Diagram (1.2 V Supplied by External Source) | 65 |
| 3.9.4 | Twisted-Pair Interface Diagram (Single Power Supply) | 66 |
| 3.9.5 | Twisted-Pair Interface Diagram (Dual Power Supplies) | 67 |
| <hr/> | | |
| Chapter 4 | Register Descriptions | 68 |
| 4.1 | Register Nomenclature | 68 |
| 4.2 | Control and Status Registers | 69 |
| 4.2.1 | Basic Control Register | 70 |
| 4.2.2 | Basic Status Register | 71 |
| 4.2.3 | PHY Identifier 1 Register | 73 |
| 4.2.4 | PHY Identifier 2 Register | 74 |
| 4.2.5 | Auto Negotiation Advertisement Register | 75 |
| 4.2.6 | Auto Negotiation Link Partner Ability Register | 76 |
| 4.2.7 | Auto Negotiation Expansion Register | 77 |
| 4.2.8 | Auto Negotiation Next Page TX Register | 78 |
| 4.2.9 | Auto Negotiation Next Page RX Register | 79 |
| 4.2.10 | MMD Access Control Register | 80 |
| 4.2.11 | MMD Access Address/Data Register | 81 |
| 4.2.12 | EDPD NLP / Crossover Time / EEE Configuration Register | 82 |
| 4.2.13 | Mode Control/Status Register | 83 |
| 4.2.14 | Special Modes Register | 84 |
| 4.2.15 | TDR Patterns/Delay Control Register | 85 |
| 4.2.16 | TDR Control/Status Register | 86 |
| 4.2.17 | Symbol Error Counter Register | 87 |
| 4.2.18 | Special Control/Status Indications Register | 88 |
| 4.2.19 | Cable Length Register | 89 |
| 4.2.20 | Interrupt Source Flag Register | 90 |
| 4.2.21 | Interrupt Mask Register | 91 |
| 4.2.22 | PHY Special Control/Status Register | 92 |
| 4.3 | MDIO Manageable Device (MMD) Registers | 93 |
| 4.3.1 | PCS Control 1 Register | 95 |
| 4.3.2 | PCS Status 1 Register | 96 |
| 4.3.3 | PCS MMD Devices Present 1 Register | 97 |
| 4.3.4 | PCS MMD Devices Present 2 Register | 98 |
| 4.3.5 | EEE Capability Register | 99 |
| 4.3.6 | EEE Wake Error Register | 100 |
| 4.3.7 | Wakeup Control and Status Register (WUCSR) | 101 |
| 4.3.8 | Wakeup Filter Configuration Register A (WUF_CFGA) | 103 |
| 4.3.9 | Wakeup Filter Configuration Register B (WUF_CFGB) | 104 |
| 4.3.10 | Wakeup Filter Byte Mask Registers (WUF_MASK) | 105 |
| 4.3.11 | MAC Receive Address A Register (RX_ADDRA) | 107 |
| 4.3.12 | MAC Receive Address B Register (RX_ADDRB) | 108 |
| 4.3.13 | MAC Receive Address C Register (RX_ADDR_C) | 109 |
| 4.3.14 | Miscellaneous Configuration Register (MCFGR) | 110 |
| 4.3.15 | Auto-Negotiation MMD Devices Present 1 Register | 111 |
| 4.3.16 | Auto-Negotiation MMD Devices Present 2 Register | 112 |
| 4.3.17 | EEE Advertisement Register | 113 |
| 4.3.18 | EEE Link Partner Advertisement Register | 114 |
| 4.3.19 | Vendor Specific MMD 1 Device ID 1 Register | 115 |
| 4.3.20 | Vendor Specific MMD 1 Device ID 2 Register | 116 |

| | | |
|------------------|--|------------|
| 4.3.21 | Vendor Specific 1 MMD Devices Present 1 Register | 117 |
| 4.3.22 | Vendor Specific 1 MMD Devices Present 2 Register | 118 |
| 4.3.23 | Vendor Specific MMD 1 Status Register | 119 |
| 4.3.24 | TDR Match Threshold Register | 120 |
| 4.3.25 | TDR Short/Open Threshold Register | 121 |
| 4.3.26 | Vendor Specific MMD 1 package ID 1 Register | 122 |
| 4.3.27 | Vendor Specific MMD 1 package ID 2 Register | 123 |
| <hr/> | | |
| Chapter 5 | Operational Characteristics | 124 |
| 5.1 | Absolute Maximum Ratings* | 124 |
| 5.2 | Operating Conditions** | 125 |
| 5.3 | Package Thermal Specifications | 125 |
| 5.4 | Power Consumption | 126 |
| 5.4.1 | Regulator Disabled | 126 |
| 5.4.2 | Regulator Enabled | 126 |
| 5.5 | DC Specifications | 127 |
| 5.6 | AC Specifications | 129 |
| 5.6.1 | Equivalent Test Load | 129 |
| 5.6.2 | Power-On nRST & Configuration Strap Timing | 130 |
| 5.6.3 | MII Interface Timing | 131 |
| 5.6.4 | RMII Interface Timing | 134 |
| 5.6.5 | SMI Timing | 136 |
| 5.7 | Clock Circuit | 137 |
| <hr/> | | |
| Chapter 6 | Package Outline | 138 |
| <hr/> | | |
| Chapter 7 | Revision History | 141 |

Datasheet

List of Figures

| | | |
|-------------|---|-----|
| Figure 1.1 | System Block Diagram | 9 |
| Figure 1.2 | Architectural Overview | 9 |
| Figure 2.1 | 32-SQFN Pin Assignments (TOP VIEW) | 10 |
| Figure 3.1 | 100BASE-TX Transmit Data Path | 21 |
| Figure 3.2 | 100BASE-TX Receive Data Path | 24 |
| Figure 3.3 | Relationship Between Received Data and Specific MII Signals | 26 |
| Figure 3.4 | Direct Cable Connection vs. Cross-over Cable Connection | 31 |
| Figure 3.5 | MDIO Timing and Frame Structure - READ Cycle | 35 |
| Figure 3.6 | MDIO Timing and Frame Structure - WRITE Cycle | 35 |
| Figure 3.7 | LED1/nINT/nPME/REGOFF with Internal Regulator Disabled | 43 |
| Figure 3.8 | LED1/nINT/nPME/REGOFF with Internal Regulator Enabled | 44 |
| Figure 3.9 | LED2/nINT/nPME with nINTSEL Enabled | 45 |
| Figure 3.10 | LED2/nINT/nPME with nINTSEL Disabled | 45 |
| Figure 3.11 | LED1/REGOFF Polarity Configuration | 46 |
| Figure 3.12 | LED2/nINTSEL Polarity Configuration | 47 |
| Figure 3.13 | TDR Usage Flow Diagram | 57 |
| Figure 3.14 | Near-end Loopback Block Diagram | 61 |
| Figure 3.15 | Far Loopback Block Diagram | 61 |
| Figure 3.16 | Connector Loopback Block Diagram | 62 |
| Figure 3.17 | Simplified System Level Application Diagram | 63 |
| Figure 3.18 | Power Supply Diagram (1.2 V Supplied by Internal Regulator) | 64 |
| Figure 3.19 | Power Supply Diagram (1.2 V Supplied by External Source) | 65 |
| Figure 3.20 | Twisted-Pair Interface Diagram (Single Power Supply) | 66 |
| Figure 3.21 | Twisted-Pair Interface Diagram (Dual Power Supplies) | 67 |
| Figure 5.1 | Output Equivalent Test Load | 129 |
| Figure 5.2 | Power-On nRST & Configuration Strap Timing | 130 |
| Figure 5.3 | MII Receive Timing | 131 |
| Figure 5.4 | MII Transmit Timing | 132 |
| Figure 5.5 | 100 Mbps Internal Loopback MII Timing | 133 |
| Figure 5.6 | RMII Timing | 134 |
| Figure 5.7 | SMI Timing | 136 |
| Figure 6.1 | 32-SQFN Package | 138 |
| Figure 6.2 | Recommended PCB Land Pattern | 139 |
| Figure 6.3 | Taping Dimensions and Part Orientation | 139 |
| Figure 6.4 | Reel Dimensions | 140 |
| Figure 6.5 | Tape Length and Part Quantity | 140 |

List of Tables

| | | |
|------------|---|-----|
| Table 2.1 | MII/RMII Signals | 11 |
| Table 2.2 | LED Pins | 15 |
| Table 2.3 | Serial Management Interface (SMI) Pins | 17 |
| Table 2.4 | Ethernet Pins | 17 |
| Table 2.5 | Miscellaneous Pins | 17 |
| Table 2.6 | Analog Reference Pins | 18 |
| Table 2.7 | Power Pins | 18 |
| Table 2.8 | 32-SQFN Package Pin Assignments | 19 |
| Table 2.9 | Buffer Types | 20 |
| Table 3.1 | 4B/5B Code Table | 22 |
| Table 3.2 | MII/RMII Signal Mapping | 34 |
| Table 3.3 | Interrupt Management Table | 37 |
| Table 3.4 | Alternative Interrupt System Management Table | 38 |
| Table 3.5 | Pin Names for Address Bits | 39 |
| Table 3.6 | MODE[2:0] Bus | 40 |
| Table 3.7 | Pin Names for Mode Bits | 40 |
| Table 3.8 | Wakeup Generation Cases | 52 |
| Table 3.9 | TDR Propagation Constants | 58 |
| Table 3.10 | Typical Measurement Error for Open Cable (+/- Meters) | 59 |
| Table 3.11 | Typical Measurement Error for Shorted Cable (+/- Meters) | 59 |
| Table 3.12 | Match Case Estimated Cable Length (CBLN) Lookup Table | 60 |
| Table 4.1 | Register Bit Types | 68 |
| Table 4.2 | SMI Register Map | 69 |
| Table 4.3 | MMD Registers | 93 |
| Table 5.1 | Package Thermal Parameters | 125 |
| Table 5.2 | Current Consumption and Power Dissipation (Reg. Disabled) | 126 |
| Table 5.3 | Current Consumption and Power Dissipation (Reg. Enabled) | 126 |
| Table 5.4 | Non-Variable I/O Buffer Characteristics | 127 |
| Table 5.5 | Variable I/O Buffer Characteristics | 128 |
| Table 5.6 | 100BASE-TX Transceiver Characteristics | 128 |
| Table 5.7 | 10BASE-T Transceiver Characteristics | 129 |
| Table 5.8 | Power-On nRST & Configuration Strap Timing Values | 130 |
| Table 5.9 | MII Receive Timing Values | 131 |
| Table 5.10 | MII Transmit Timing Values | 132 |
| Table 5.11 | 100 Mbps Internal Loopback MII Timing Values | 133 |
| Table 5.12 | RMII Timing Values | 135 |
| Table 5.13 | RMII CLKIN (REF_CLK) Timing Values | 135 |
| Table 5.14 | SMI Timing Values | 136 |
| Table 5.15 | Crystal Specifications | 137 |
| Table 6.1 | 32-SQFN Dimensions | 138 |
| Table 7.1 | Customer Revision History | 141 |

Chapter 1 Introduction

1.1 General Terms and Conventions

The following is a list of the general terms used throughout this document:

| | |
|-----------------|--|
| BYTE | 8 bits |
| FIFO | First In First Out buffer; often used for elasticity buffer |
| MAC | Media Access Controller |
| MII | Media Independent Interface |
| RMII™ | Reduced Media Independent Interface |
| N/A | Not Applicable |
| X | Indicates that a logic state is “don’t care” or undefined. |
| RESERVED | Refers to a reserved bit field or address. Unless otherwise noted, reserved bits must always be zero for write operations. Unless otherwise noted, values are not guaranteed when reading reserved bits. Unless otherwise noted, do not read or write to reserved addresses. |
| SMI | Serial Management Interface |

1.2 General Description

The LAN8740A/LAN8740Ai is a low-power 10BASE-T/100BASE-TX physical layer (PHY) transceiver with variable I/O voltage that is compliant with the IEEE 802.3, 802.3u, and 802.3az (Energy Efficient Ethernet) standards. Energy Efficient Ethernet (EEE) support results in significant power savings during low link utilizations.

The LAN8740A/LAN8740Ai supports communication with an Ethernet MAC via a standard MII (IEEE 802.3u)/RMII interface. It contains a full-duplex 10-BASE-T/100BASE-TX transceiver and supports 10 Mbps (10BASE-T) and 100 Mbps (100BASE-TX) operation. The LAN8740A/LAN8740Ai implements auto-negotiation to automatically determine the best possible speed and duplex mode of operation. HP Auto-MDIX support allows the use of direct connect or cross-over LAN cables. Integrated Wake on LAN (WoL) support provides a mechanism to trigger an interrupt upon reception of a perfect DA, broadcast, magic packet, or wakeup frame.

The LAN8740A/LAN8740Ai supports both IEEE 802.3-2005 compliant and vendor-specific register functions. However, no register access is required for operation. The initial configuration may be selected via the configuration pins as described in [Section 3.7, "Configuration Straps," on page 39](#). Register-selectable configuration options may be used to further define the functionality of the transceiver.

The LAN8740A/LAN8740Ai can be programmed to support wake-on-LAN at the physical layer, allowing detection of configurable Wake-up Frame and Magic packets. This feature allows filtering of packets at the PHY layer, without requiring MAC intervention. Additionally, the LAN8740A/LAN8740Ai supports cable diagnostics which allow the device to identify opens/shorts and their location on the cable via vendor-specific registers.

Per IEEE 802.3-2005 standards, all digital interface pins are tolerant to 3.6 V. The device can be configured to operate on a single 3.3 V supply utilizing an integrated 3.3 V to 1.2 V linear regulator.

The linear regulator may be optionally disabled, allowing usage of a high efficiency external regulator for lower system power dissipation.

The LAN8740A/LAN8740Ai is available in commercial (0°C to +70°C) and industrial (-40°C to +85°C) temperature range versions. A typical system application is shown in Figure 1.1. Figure 1.2 provides an internal block diagram of the device.

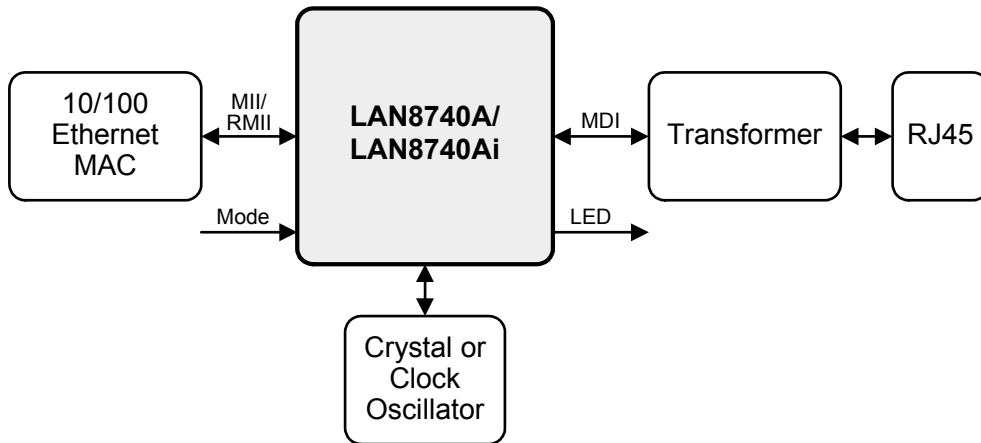

Figure 1.1 System Block Diagram

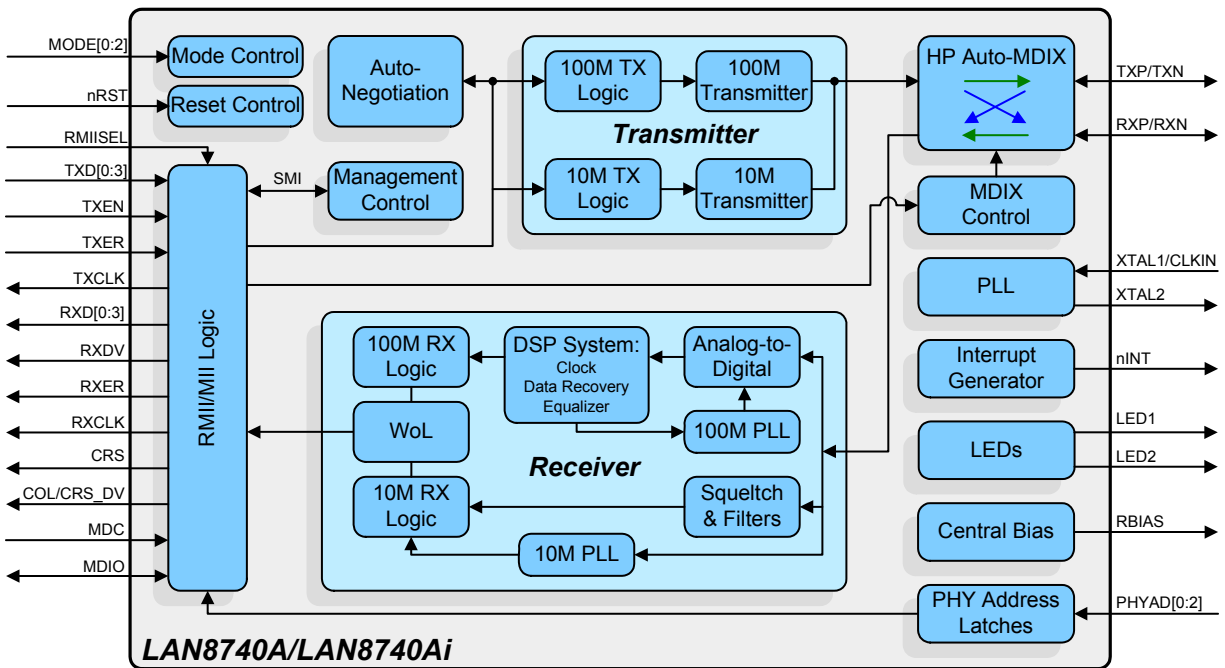
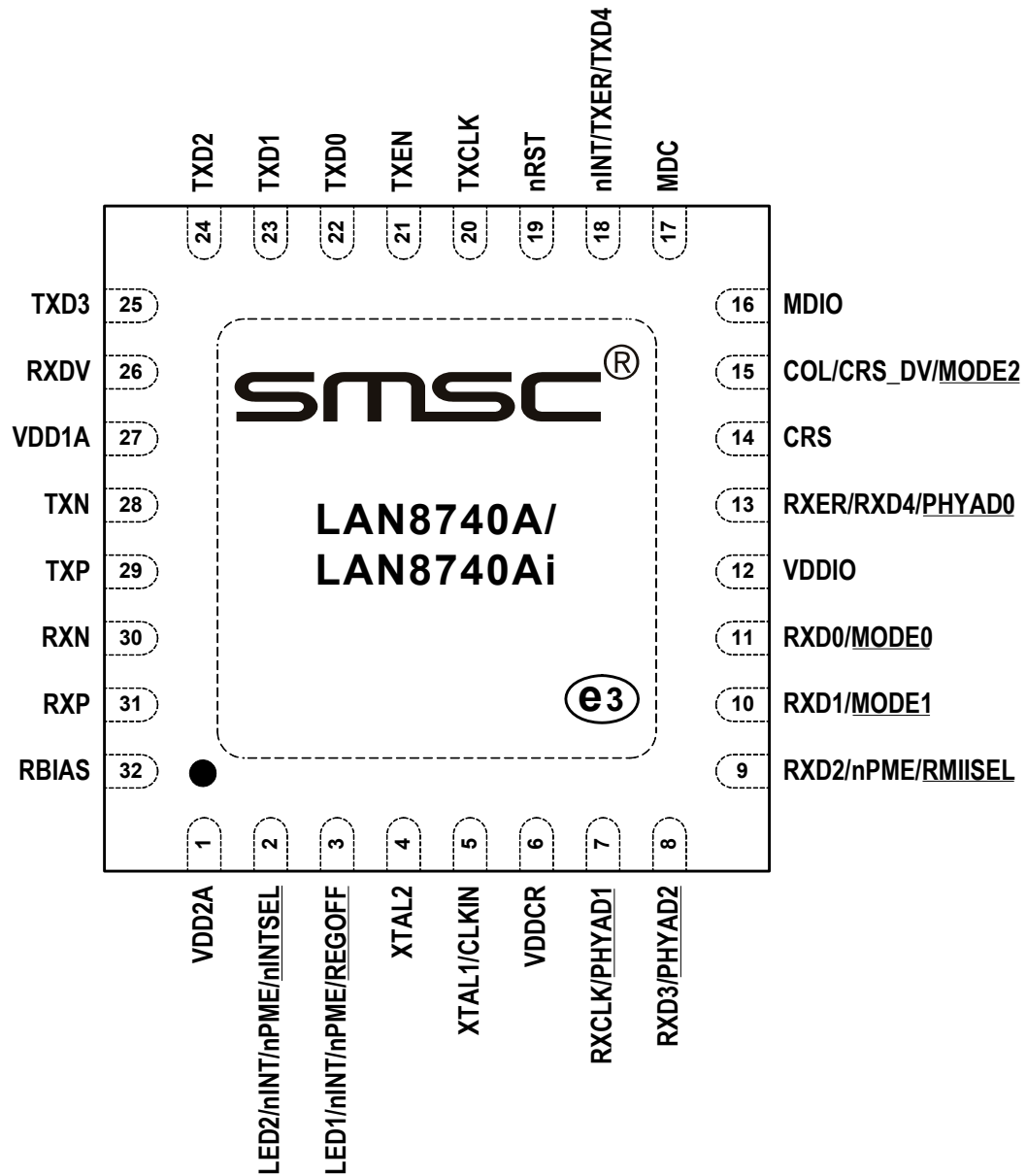

Figure 1.2 Architectural Overview

Chapter 2 Pin Description and Configuration



Note: Exposed pad (VSS) on bottom of package must be connected to ground.

Figure 2.1 32-SQFN Pin Assignments (TOP VIEW)

Note: When a lower case “n” is used at the beginning of the signal name, it indicates that the signal is active low. For example, nRST indicates that the reset signal is active low.

Note: The buffer type for each signal is indicated in the BUFFER TYPE column. A description of the buffer types is provided in [Section 2.2](#).

Table 2.1 MII/RMII Signals

| NUM PINS | NAME | SYMBOL | BUFFER TYPE | DESCRIPTION |
|----------|----------------------------|--------|-------------|--|
| 1 | Transmit Data 0 | TXD0 | VIS | The MAC transmits data to the transceiver using this signal in all modes. |
| 1 | Transmit Data 1 | TXD1 | VIS | The MAC transmits data to the transceiver using this signal in all modes. |
| 1 | Transmit Data 2 (MII Mode) | TXD2 | VIS | The MAC transmits data to the transceiver using this signal in MII mode. Note: This signal must be grounded in RMII mode. |
| 1 | Transmit Data 3 (MII Mode) | TXD3 | VIS | The MAC transmits data to the transceiver using this signal in MII mode. Note: This signal must be grounded in RMII mode. |
| 1 | Interrupt Output | nINT | VOD8 (PU) | Active low interrupt output. Place an external resistor pull-up to VDDIO. Note: The nINT signal can be optionally configured to output on the LED1 or LED2 pins. Refer to Section 3.6, "Interrupt Management," on page 36 for additional details on device interrupts. Note: Refer to Section 3.8.1.6, "nINTSEL and LED2 Polarity Selection," on page 47 for details on how the nINTSEL configuration strap is used to determine the function of this pin. |
| | Transmit Error (MII Mode) | TXER | VIS | When driven high, the 4B/5B encode process substitutes the Transmit Error code-group (/H/) for the encoded data word. This input is ignored in the 10BASE-T mode of operation. This signal is also used in EEE mode as TXER when TXEN = 1, and as LPI when TXEN = 0. Note: This signal is not used in RMII mode. |
| | Transmit Data 4 (MII Mode) | TXD4 | VIS (PU) | In Symbol Interface (5B decoding) mode, this signal becomes the MII Transmit Data 4 line (the MSB of the 5-bit symbol code-group). Note: This signal is not used in RMII mode. |
| 1 | Transmit Enable | TXEN | VIS (PD) | Indicates that valid transmission data is present on TXD[3:0]. In RMII mode, only TXD[1:0] provide valid data. |
| 1 | Transmit Clock (MII Mode) | TXCLK | VO8 | Used to latch data from the MAC into the transceiver. <ul style="list-style-type: none"> ■ MII (100BASE-TX): 25 MHz ■ MII (10BASE-T): 2.5 MHz Note: This signal is not used in RMII mode. |

Datasheet

Table 2.1 MII/RMII Signals (continued)

| NUM PINS | NAME | SYMBOL | BUFFER TYPE | DESCRIPTION |
|----------|--|----------------|-------------|---|
| 1 | Receive Data 0 | RXD0 | VO8 | Bit 0 of the 4 (2 in RMII mode) data bits that are sent by the transceiver on the receive path. |
| | PHY Operating Mode 0 Configuration Strap | <u>MODE0</u> | VIS (PU) | Combined with MODE1 and MODE2, this configuration strap sets the default PHY mode. See Note 2.1 for more information on configuration straps. Note: Refer to Section 3.7.2, "MODE[2:0]: Mode Configuration," on page 40 for additional details. |
| 1 | Receive Data 1 | RXD1 | VO8 | Bit 1 of the 4 (2 in RMII mode) data bits that are sent by the transceiver on the receive path. |
| | PHY Operating Mode 1 Configuration Strap | <u>MODE1</u> | VIS (PU) | Combined with MODE0 and MODE2, this configuration strap sets the default PHY mode. See Note 2.1 for more information on configuration straps. Note: Refer to Section 3.7.2, "MODE[2:0]: Mode Configuration," on page 40 for additional details. |
| 1 | Receive Data 2 (MII Mode) | RXD2 | VO8 | Bit 2 of the 4 (in MII mode) data bits that are sent by the transceiver on the receive path. Note: This signal is not used in RMII mode. |
| | Power Management Event Output | nPME | VO8 | When in RMII mode, this pin may be used alternatively as an active low Power Management Event (PME) output. Note: The nPME signal can be optionally configured to output on the LED1, LED2, or RXD2/nPME/nINTSEL pins. Refer to Section 3.8.4, "Wake on LAN (WoL)," on page 48 for additional nPME and WoL information. |
| | MII/RMII Mode Select Configuration Strap | <u>RMIISEL</u> | VIS (PD) | This configuration strap selects the MII or RMII mode of operation. When strapped low to VSS, MII mode is selected. When strapped high to VDDIO RMII mode is selected. See Note 2.1 for more information on configuration straps. Note: Refer to Section 3.7.3, "RMIISEL: MII/RMII Mode Configuration," on page 41 for additional details. |

Table 2.1 MII/RMII Signals (continued)

| NUM PINS | NAME | SYMBOL | BUFFER TYPE | DESCRIPTION |
|----------|-----------------------------------|---------------|-------------|---|
| 1 | Receive Data 3 (MII Mode) | RXD3 | VO8 | Bit 3 of the 4 (in MII mode) data bits that are sent by the transceiver on the receive path. Note: This signal is not used in RMII mode. |
| | PHY Address 2 Configuration Strap | <u>PHYAD2</u> | VIS (PD) | Combined with PHYAD0 and PHYAD1, this configuration strap sets the transceiver's SMI address. See Note 2.1 for more information on configuration straps. Note: Refer to Section 3.7.1, "PHYAD[2:0]: PHY Address Configuration," on page 39 for additional information. |
| 1 | Receive Error | RXER | VO8 | This signal is asserted to indicate that an error was detected somewhere in the frame presently being transferred from the transceiver. This signal is also used in EEE mode as RXER when RXDV = 1, and as LPI when RXDV = 0. Note: This signal is optional in RMII mode. |
| | Receive Data 4 (MII Mode) | RXD4 | VO8 | In Symbol Interface (5B decoding) mode, this signal is the MII Receive Data 4 signal, the MSB of the received 5-bit symbol code-group. Note: Unless configured to the Symbol Interface mode, this pin functions as RXER. |
| | PHY Address 0 Configuration Strap | <u>PHYAD0</u> | VIS (PD) | Combined with PHYAD1 and PHYAD2, this configuration strap sets the transceiver's SMI address. See Note 2.1 for more information on configuration straps. Note: Refer to Section 3.7.1, "PHYAD[2:0]: PHY Address Configuration," on page 39 for additional information. |
| 1 | Receive Clock (MII Mode) | RXCLK | VO8 | In MII mode, this pin is the receive clock output. <ul style="list-style-type: none"> ■ MII (100BASE-TX): 25 MHz ■ MII (10BASE-T): 2.5 MHz |
| | PHY Address 1 Configuration Strap | <u>PHYAD1</u> | VIS (PD) | Combined with PHYAD0 and PHYAD2, this configuration strap sets the transceiver's SMI address. See Note 2.1 for more information on configuration straps. Note: Refer to Section 3.7.1, "PHYAD[2:0]: PHY Address Configuration," on page 39 for additional information. |
| 1 | Receive Data Valid | RXDV | VO8 | Indicates that recovered and decoded data is available on the RXD pins. |

Datasheet

Table 2.1 MII/RMII Signals (continued)

| NUM PINS | NAME | SYMBOL | BUFFER TYPE | DESCRIPTION |
|----------|--|--------------|-------------|--|
| 1 | Collision Detect (MII Mode) | COL | VO8 | This signal is asserted to indicate detection of a collision condition in MII mode. |
| | Carrier Sense / Receive Data Valid (RMII Mode) | CRS_DV | VO8 | This signal is asserted to indicate the receive medium is non-idle in RMII mode. When a 10BASE-T packet is received, CRS_DV is asserted, but RXD[1:0] is held low until the SFD byte (10101011) is received. Note: Per the RMII standard, transmitted data is not looped back onto the receive data pins in 10BASE-T half-duplex mode. |
| | PHY Operating Mode 2 Configuration Strap | <u>MODE2</u> | VIS (PU) | Combined with MODE0 and MODE1, this configuration strap sets the default PHY mode. See Note 2.1 for more information on configuration straps. Note: Refer to Section 3.7.2, "MODE[2:0]: Mode Configuration," on page 40 for additional details. |
| 1 | Carrier Sense (MII Mode) | CRS | VO8 (PD) | This signal indicates detection of a carrier in MII mode. |

Note 2.1 Configuration strap values are latched on power-on reset and system reset. Configuration straps are identified by an underlined symbol name. Signals that function as configuration straps must be augmented with an external resistor when connected to a load. Refer to [Section 3.7, "Configuration Straps,"](#) on page 39 for additional information.

Table 2.2 LED Pins

| NUM PINS | NAME | SYMBOL | BUFFER TYPE | DESCRIPTION |
|----------|-----------------------------------|---------------|-------------|--|
| 1 | LED 1 | LED1 | O12 | <p>This pin can be used to indicate link activity, link speed, nINT, or nPME as configured via the LED1 Function Select field of the Wakeup Control and Status Register (WUCSR).</p> <p>Note: Refer to Section 3.8.1, "LEDs," on page 43 and Section 3.8.4, "Wake on LAN (WoL)," on page 48 for additional LED information.</p> |
| | Interrupt Output | nINT | O12 | <p>Active low interrupt output.</p> <p>Note: By default, the nINT signal is output on the nINT/TXER/TXD4 pin. The nINT signal can be optionally configured to output on the LED1 or LED2 pins. Refer to Section 3.6, "Interrupt Management," on page 36 for additional details on device interrupts.</p> |
| | Power Management Event Output | nPME | O12 | <p>Active low Power Management Event (PME) output.</p> <p>Note: The nPME signal can be optionally configured to output on the LED1, LED2, or RXD2/nPME/nINTSEL pins. Refer to Section 3.8.4, "Wake on LAN (WoL)," on page 48 for additional nPME and WoL information.</p> |
| | Regulator Off Configuration Strap | <u>REGOFF</u> | IS (PD) | <p>This configuration strap is used to disable the internal 1.2 V regulator. When the regulator is disabled, external 1.2 V must be supplied to VDDCR.</p> <ul style="list-style-type: none"> ■ When <u>REGOFF</u> is pulled high to VDD2A with an external resistor, the internal regulator is disabled. ■ When <u>REGOFF</u> is floating or pulled low, the internal regulator is enabled (default). <p>See Note 2.2 for more information on configuration straps.</p> <p>Note: Refer to Section 3.7.4, "REGOFF: Internal +1.2 V Regulator Configuration," on page 41 for additional details.</p> |

Datasheet

Table 2.2 LED Pins (continued)

| NUM PINS | NAME | SYMBOL | BUFFER TYPE | DESCRIPTION |
|----------|--|----------------|-------------|--|
| 1 | LED 2 | LED2 | O12 | This pin can be used to indicate link activity, link speed, nINT, or nPME as configured via the LED2 Function Select field of the Wakeup Control and Status Register (WUCSR) . Note: Refer to Section 3.8.1, "LEDs," on page 43 and Section 3.8.4, "Wake on LAN (WoL)," on page 48 for additional LED information. |
| | Interrupt Output | nINT | O12 | Active low interrupt output. Note: By default, the nINT signal is output on the nINT/TXER/TXD4 pin. The nINT signal can be optionally configured to output on the LED1 or LED2 pins. Refer to Section 3.6, "Interrupt Management," on page 36 for additional details on device interrupts. |
| | Power Management Event Output | nPME | O12 | Active low Power Management Event (PME) output. Note: The nPME signal can be optionally configured to output on the LED1, LED2, or RXD2/nPME/nINTSEL pins. Refer to Section 3.8.4, "Wake on LAN (WoL)," on page 48 for additional nPME and WoL information. |
| | nINT/TXER/TXD4 Function Select Configuration Strap | <u>nINTSEL</u> | IS (PU) | This configuration strap selects the mode of the nINT/TXER/TXD4 pin. <ul style="list-style-type: none">■ When <u>nINTSEL</u> is floated or pulled to VDD2A, nINT is selected for operation on the nINT/TXER/TXD4 pin (default).■ When <u>nINTSEL</u> is pulled low to VSS, TXER/TXD4 is selected for operation on the nINT/TXER/TXD4 pin. See Note 2.2 for more information on configuration straps. Note: Refer to See Section 3.8.1.6, "nINTSEL and LED2 Polarity Selection," on page 47 for additional information. |

Note 2.2 Configuration strap values are latched on power-on reset and system reset. Configuration straps are identified by an underlined symbol name. Signals that function as configuration straps must be augmented with an external resistor when connected to a load. Refer to [Section 3.7, "Configuration Straps,"](#) on page 39 for additional information.

Table 2.3 Serial Management Interface (SMI) Pins

| NUM PINS | NAME | SYMBOL | BUFFER TYPE | DESCRIPTION |
|----------|-----------------------|--------|---------------------|---|
| 1 | SMI Data Input/Output | MDIO | VIS/ VO8 (PU) | Serial Management Interface data input/output |
| 1 | SMI Clock | MDC | VIS | Serial Management Interface clock |

Table 2.4 Ethernet Pins

| NUM PINS | NAME | SYMBOL | BUFFER TYPE | DESCRIPTION |
|----------|-----------------------------------|--------|-------------|-------------------------------------|
| 1 | Ethernet TX/RX Positive Channel 1 | TXP | AIO | Transmit/Receive Positive Channel 1 |
| 1 | Ethernet TX/RX Negative Channel 1 | TXN | AIO | Transmit/Receive Negative Channel 1 |
| 1 | Ethernet TX/RX Positive Channel 2 | RXP | AIO | Transmit/Receive Positive Channel 2 |
| 1 | Ethernet TX/RX Negative Channel 2 | RXN | AIO | Transmit/Receive Negative Channel 2 |

Table 2.5 Miscellaneous Pins

| NUM PINS | NAME | SYMBOL | BUFFER TYPE | DESCRIPTION |
|----------|-------------------------|--------|-------------|--|
| 1 | External Crystal Input | XTAL1 | ICLK | External crystal input |
| | External Clock Input | CLKIN | ICLK | Single-ended clock oscillator input. Note: When using a single ended clock oscillator, XTAL2 should be left unconnected. |
| 1 | External Crystal Output | XTAL2 | OCLK | External crystal output |
| 1 | External Reset | nRST | VIS (PU) | System reset. This signal is active low. |

Datasheet

Table 2.6 Analog Reference Pins

| NUM PINS | NAME | SYMBOL | BUFFER TYPE | DESCRIPTION |
|----------|---------------------------------|--------|-------------|--|
| 1 | External 1% Bias Resistor Input | RBIAS | AI | <p>This pin requires connection of a 12.1 kΩ (1%) resistor to ground.</p> <p>Refer to the LAN8740A/LAN8740Ai reference schematic for connection information.</p> <p>Note: The nominal voltage is 1.2 V and the resistor will dissipate approximately 1 mW of power.</p> |

Table 2.7 Power Pins

| NUM PINS | NAME | SYMBOL | BUFFER TYPE | DESCRIPTION |
|----------|-------------------------------------|--------|-------------|--|
| 1 | +1.8 V to +3.3 V Variable I/O Power | VDDIO | P | <p>+1.8 V to +3.3 V variable I/O power.</p> <p>Refer to the LAN8740A/LAN8740Ai reference schematic for connection information.</p> |
| 1 | +1.2 V Digital Core Power Supply | VDDCR | P | <p>Supplied by the on-chip regulator unless configured for regulator off mode via the <u>REGOFF</u> configuration strap.</p> <p>Refer to the LAN8740A/LAN8740Ai reference schematic for connection information.</p> <p>Note: 1 μF and 470 pF decoupling capacitors in parallel to ground should be used on this pin.</p> |
| 1 | +3.3 V Channel 1 Analog Port Power | VDD1A | P | <p>+3.3 V Analog Port Power to Channel 1.</p> <p>Refer to the LAN8740A/LAN8740Ai reference schematic for connection information.</p> |
| 1 | +3.3 V Channel 2 Analog Port Power | VDD2A | P | <p>+3.3 V Analog Port Power to Channel 2 and the internal regulator.</p> <p>Refer to the LAN8740A/LAN8740Ai reference schematic for connection information.</p> |
| 1 | Ground | VSS | P | <p>Common ground. This exposed pad must be connected to the ground plane with a via array.</p> |

2.1 Pin Assignments

Table 2.8 32-SQFN Package Pin Assignments

| PIN NUM | PIN NAME | PIN NUM | PIN NAME |
|---------|------------------------|---------|----------------|
| 1 | VDD2A | 17 | MDC |
| 2 | LED2/nINT/nPME/nINTSEL | 18 | nINT/TXER/TXD4 |
| 3 | LED1/nINT/nPME/REGOFF | 19 | nRST |
| 4 | XTAL2 | 20 | TXCLK |
| 5 | XTAL1/CLKIN | 21 | TXEN |
| 6 | VDDCR | 22 | TXD0 |
| 7 | RXCLK/PHYAD1 | 23 | TXD1 |
| 8 | RXD3/PHYAD2 | 24 | TXD2 |
| 9 | RXD2/nPME/RMIISEL | 25 | TXD3 |
| 10 | RXD1/MODE1 | 26 | RXDV |
| 11 | RXD0/MODE0 | 27 | VDD1A |
| 12 | VDDIO | 28 | TXN |
| 13 | RXER/RXD4/PHYAD0 | 29 | TXP |
| 14 | CRS | 30 | RXN |
| 15 | COL/CRS_DV/MODE2 | 31 | RXP |
| 16 | MDIO | 32 | RBIAS |

Datasheet

2.2 Buffer Types

Table 2.9 Buffer Types

| BUFFER TYPE | DESCRIPTION |
|-------------|---|
| IS | Schmitt-triggered input |
| O12 | Output with 12 mA sink and 12 mA source |
| VIS | Variable voltage Schmitt-triggered input |
| VO8 | Variable voltage output with 8 mA sink and 8 mA source |
| VOD8 | Variable voltage open-drain output with 8 mA sink |
| PU | 50 μ A (typical) internal pull-up. Unless otherwise noted in the pin description, internal pull-ups are always enabled. Note: Internal pull-up resistors prevent unconnected inputs from floating. Do not rely on internal resistors to drive signals external to the device. When connected to a load that must be pulled high, an external resistor must be added. |
| PD | 50 μ A (typical) internal pull-down. Unless otherwise noted in the pin description, internal pull-downs are always enabled. Note: Internal pull-down resistors prevent unconnected inputs from floating. Do not rely on internal resistors to drive signals external to the device. When connected to a load that must be pulled low, an external resistor must be added. |
| AI | Analog input |
| AIO | Analog bi-directional |
| ICLK | Crystal oscillator input pin |
| OCLK | Crystal oscillator output pin |
| P | Power pin |

Note: The digital signals are not 5 V tolerant. Refer to [Section 5.1, "Absolute Maximum Ratings*,"](#) on [page 124](#) for additional buffer information.

Note: Sink and source capabilities are dependant on the VDDIO voltage. Refer to [Section 5.1, "Absolute Maximum Ratings*,"](#) on [page 124](#) for additional information.

Chapter 3 Functional Description

This chapter provides functional descriptions of the various device features. These features have been categorized into the following sections:

- Transceiver
- Auto-Negotiation
- HP Auto-MDIX Support
- MAC Interface
- Serial Management Interface (SMI)
- Interrupt Management
- Configuration Straps
- Miscellaneous Functions
- Application Diagrams

3.1 Transceiver

3.1.1 100BASE-TX Transmit

The 100BASE-TX transmit data path is shown in [Figure 3.1](#). Each major block is explained in the following subsections.

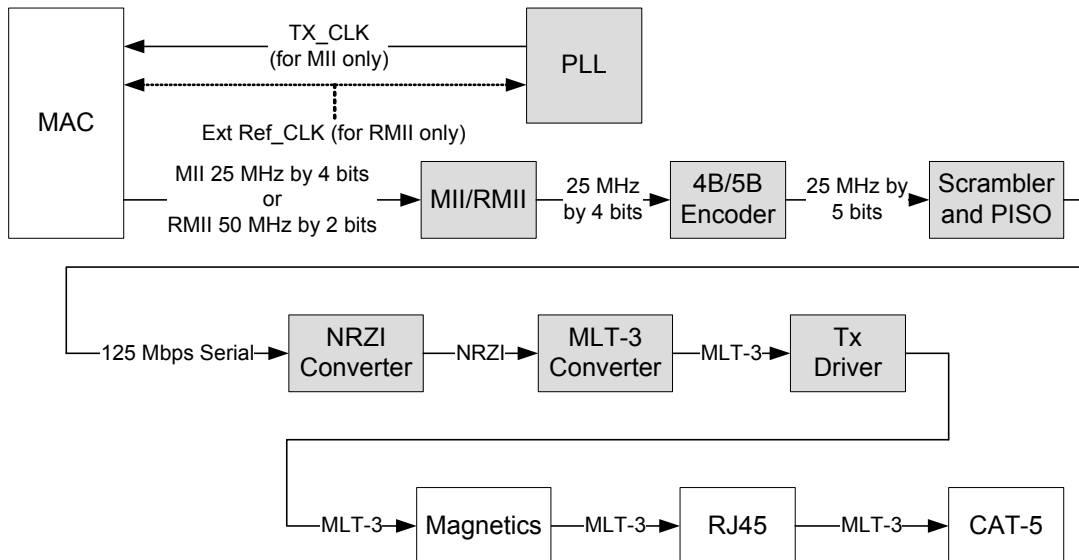

Figure 3.1 100BASE-TX Transmit Data Path

Datasheet

3.1.1.1 100BASE-TX Transmit Data Across the MII/RMII Interface

For MII, the MAC controller drives the transmit data onto the TXD bus and asserts TXEN to indicate valid data. The data is latched by the transceiver's MII block on the rising edge of TXCLK. The data is in the form of 4-bit wide 25 MHz data.

For RMII, the MAC controller drives the transmit data onto the TXD bus and asserts TXEN to indicate valid data. The data is latched by the transceiver's RMII block on the rising edge of REF_CLK. The data is in the form of 2-bit wide 50 MHz data.

3.1.1.2 4B/5B Encoding

The transmit data passes from the MII/RMII block to the 4B/5B encoder. This block encodes the data from 4-bit nibbles to 5-bit symbols (known as "code-groups") according to [Table 3.1](#). Each 4-bit data-nibble is mapped to 16 of the 32 possible code-groups. The remaining 16 code-groups are either used for control information or are not valid.

The first 16 code-groups are referred to by the hexadecimal values of their corresponding data nibbles, 0 through F. The remaining code-groups are given letter designations with slashes on either side. For example, an IDLE code-group is /I/, a transmit error code-group is /H/, etc.

Table 3.1 4B/5B Code Table

| CODE GROUP | SYM | RECEIVER INTERPRETATION | | | TRANSMITTER INTERPRETATION | | |
|------------|-----|---|------|------|----------------------------|------|------|
| | | | | | | | |
| 11110 | 0 | 0 | 0000 | DATA | 0 | 0000 | DATA |
| 01001 | 1 | 1 | 0001 | | 1 | 0001 | |
| 10100 | 2 | 2 | 0010 | | 2 | 0010 | |
| 10101 | 3 | 3 | 0011 | | 3 | 0011 | |
| 01010 | 4 | 4 | 0100 | | 4 | 0100 | |
| 01011 | 5 | 5 | 0101 | | 5 | 0101 | |
| 01110 | 6 | 6 | 0110 | | 6 | 0110 | |
| 01111 | 7 | 7 | 0111 | | 7 | 0111 | |
| 10010 | 8 | 8 | 1000 | | 8 | 1000 | |
| 10011 | 9 | 9 | 1001 | | 9 | 1001 | |
| 10110 | A | A | 1010 | | A | 1010 | |
| 10111 | B | B | 1011 | | B | 1011 | |
| 11010 | C | C | 1100 | | C | 1100 | |
| 11011 | D | D | 1101 | | D | 1101 | |
| 11100 | E | E | 1110 | | E | 1110 | |
| 11101 | F | F | 1111 | | F | 1111 | |
| 11111 | I | IDLE | | | Sent after /T/R until TXEN | | |
| 11000 | J | First nibble of SSD, translated to "0101" following IDLE, else RXER | | | Sent for rising TXEN | | |

Table 3.1 4B/5B Code Table (continued)

| CODE GROUP | SYM | RECEIVER INTERPRETATION | TRANSMITTER INTERPRETATION |
|------------|-----|--|---|
| 10001 | K | Second nibble of SSD, translated to "0101" following J, else RXER | Sent for rising TXEN |
| 01101 | T | First nibble of ESD, causes de-assertion of CRS if followed by /R/, else assertion of RXER | Sent for falling TXEN |
| 00111 | R | Second nibble of ESD, causes deassertion of CRS if following /T/, else assertion of RXER | Sent for falling TXEN |
| 00100 | H | Transmit Error Symbol | Sent for rising TXER |
| 00110 | V | INVALID, RXER if during RXDV | INVALID |
| 11001 | V | INVALID, RXER if during RXDV | INVALID |
| 00000 | V | Indicates to receiver that the transmitter will be going to LPI | Sent due to LPI. Used to tell receiver before transmitter goes to LPI. Also used for refresh cycles during LPI. |
| 00001 | V | INVALID, RXER if during RXDV | INVALID |
| 00010 | V | INVALID, RXER if during RXDV | INVALID |
| 00011 | V | INVALID, RXER if during RXDV | INVALID |
| 00101 | V | INVALID, RXER if during RXDV | INVALID |
| 01000 | V | INVALID, RXER if during RXDV | INVALID |
| 01100 | V | INVALID, RXER if during RXDV | INVALID |
| 10000 | V | INVALID, RXER if during RXDV | INVALID |

3.1.1.3 Scrambling

Repeated data patterns (especially the IDLE code-group) can have power spectral densities with large narrow-band peaks. Scrambling the data helps eliminate these peaks and spread the signal power more uniformly over the entire channel bandwidth. This uniform spectral density is required by FCC regulations to prevent excessive EMI from being radiated by the physical wiring.

The seed for the scrambler is generated from the transceiver address, [PHYAD](#), ensuring that in multiple-transceiver applications, such as repeaters or switches, each transceiver will have its own scrambler sequence.

The scrambler also performs the Parallel In Serial Out conversion (PISO) of the data.

3.1.1.4 NRZI and MLT-3 Encoding

The scrambler block passes the 5-bit wide parallel data to the NRZI converter where it becomes a serial 125 MHz NRZI data stream. The NRZI is encoded to MLT-3. MLT-3 is a tri-level code where a change in the logic level represents a code bit "1" and the logic output remaining at the same level represents a code bit "0".

Datasheet

3.1.1.5 100M Transmit Driver

The MLT3 data is then passed to the analog transmitter, which drives the differential MLT-3 signal, on outputs TXP and TXN, to the twisted pair media across a 1:1 ratio isolation transformer. The 10BASE-T and 100BASE-TX signals pass through the same transformer so that common “magnetics” can be used for both. The transmitter drives into the 100 Ω impedance of the CAT-5 cable. Cable termination and impedance matching require external components.

3.1.1.6 100M Phase Lock Loop (PLL)

The 100M PLL locks onto reference clock and generates the 125 MHz clock used to drive the 125 MHz logic and the 100BASE-TX transmitter.

3.1.2 100BASE-TX Receive

The 100BASE-TX receive data path is shown in [Figure 3.2](#). Each major block is explained in the following subsections.

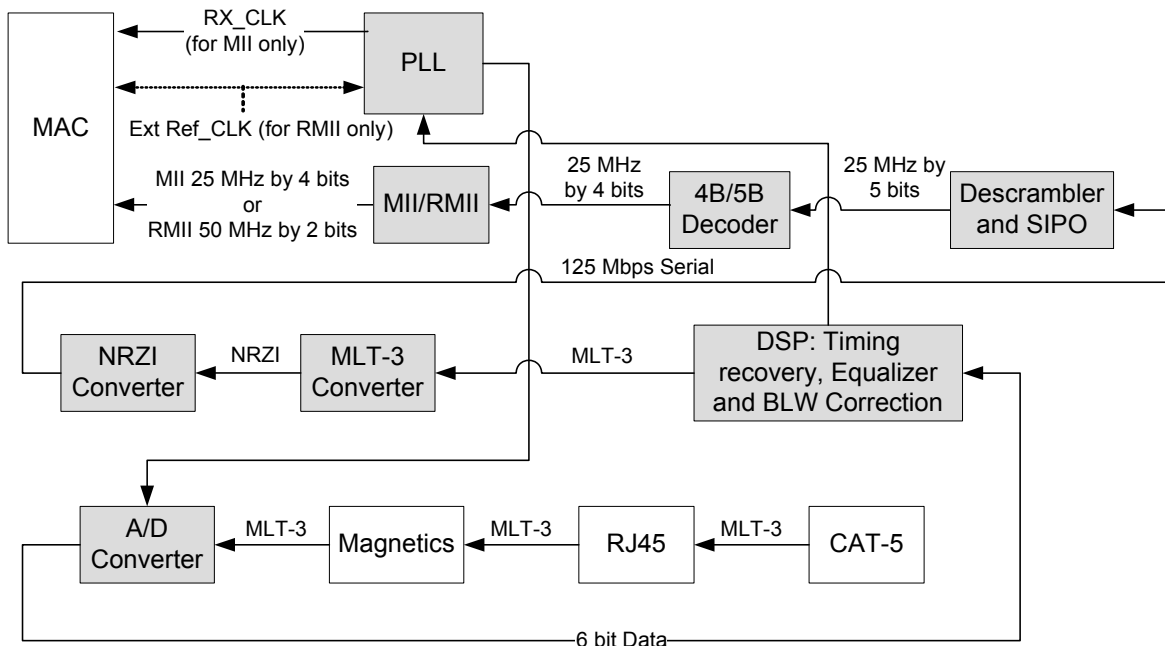

Figure 3.2 100BASE-TX Receive Data Path

3.1.2.1 100M Receive Input

The MLT-3 from the cable is fed into the transceiver (on inputs RXP and RXN) via a 1:1 ratio transformer. The ADC samples the incoming differential signal at a rate of 125M samples per second. Using a 64-level quantizer, it generates 6 digital bits to represent each sample. The DSP adjusts the gain of the ADC according to the observed signal levels such that the full dynamic range of the ADC can be used.

3.1.2.2 Equalizer, Baseline Wander Correction and Clock and Data Recovery

The 6 bits from the ADC are fed into the DSP block. The equalizer in the DSP section compensates for phase and amplitude distortion caused by the physical channel consisting of magnetics, connectors, and CAT-5 cable. The equalizer can restore the signal for any good-quality CAT-5 cable between 1 m and 100 m.

If the DC content of the signal is such that the low-frequency components fall below the low frequency pole of the isolation transformer, then the droop characteristics of the transformer will become significant and Baseline Wander (BLW) on the received signal will result. To prevent corruption of the received data, the transceiver corrects for BLW and can receive the ANSI X3.263-1995 FDDI TP-PMD defined “killer packet” with no bit errors.

The 100M PLL generates multiple phases of the 125 MHz clock. A multiplexer, controlled by the timing unit of the DSP, selects the optimum phase for sampling the data. This is used as the received recovered clock. This clock is used to extract the serial data from the received signal.

3.1.2.3 NRZI and MLT-3 Decoding

The DSP generates the MLT-3 recovered levels that are fed to the MLT-3 converter. The MLT-3 is then converted to an NRZI data stream.

3.1.2.4 Descrambling

The descrambler performs an inverse function to the scrambler in the transmitter and also performs the Serial In Parallel Out (SIPO) conversion of the data.

During reception of IDLE (/I/) symbols, the descrambler synchronizes its descrambler key to the incoming stream. Once synchronization is achieved, the descrambler locks on this key and is able to descramble incoming data.

Special logic in the descrambler ensures synchronization with the remote transceiver by searching for IDLE symbols within a window of 4000 bytes (40 μ s). This window ensures that a maximum packet size of 1514 bytes, allowed by the IEEE 802.3 standard, can be received with no interference. If no IDLE-symbols are detected within this time-period, receive operation is aborted and the descrambler re-starts the synchronization process.

3.1.2.5 Alignment

The de-scrambled signal is then aligned into 5-bit code-groups by recognizing the /J/K/ Start-of-Stream Delimiter (SSD) pair at the start of a packet. Once the code-word alignment is determined, it is stored and utilized until the next start of frame.

3.1.2.6 5B/4B Decoding

The 5-bit code-groups are translated into 4-bit data nibbles according to the 4B/5B table. The translated data is presented on the RXD[3:0] signal lines. The SSD, /J/K/, is translated to “0101 0101” as the first 2 nibbles of the MAC preamble. Reception of the SSD causes the transceiver to assert the receive data valid signal, indicating that valid data is available on the RXD bus. Successive valid code-groups are translated to data nibbles. Reception of either the End of Stream Delimiter (ESD) consisting of the /T/R/ symbols, or at least two /I/ symbols causes the transceiver to de-assert the carrier sense and receive data valid signals.

Note: These symbols are not translated into data.

Datasheet

3.1.2.7 Receive Data Valid Signal

The Receive Data Valid signal (RXDV) indicates that recovered and decoded nibbles are being presented on the RXD[3:0] outputs synchronous to RXCLK. RXDV becomes active after the /J/K/ delimiter has been recognized and RXD is aligned to nibble boundaries. It remains active until either the /T/R/ delimiter is recognized or link test indicates failure or SIGDET becomes false.

RXDV is asserted when the first nibble of translated /J/K/ is ready for transfer over the Media Independent Interface (MII mode).

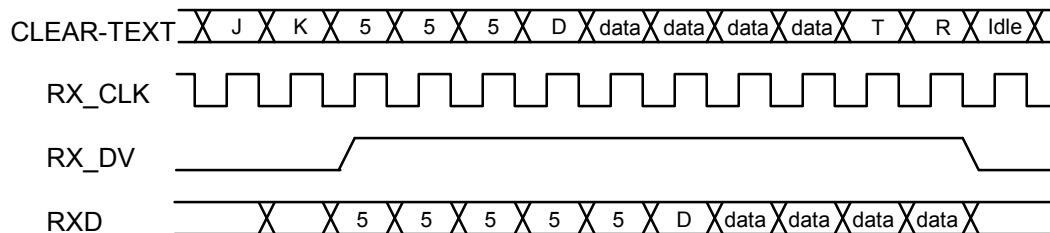

Figure 3.3 Relationship Between Received Data and Specific MII Signals

3.1.2.8 Receiver Errors

During a frame, unexpected code-groups are considered receive errors. Expected code groups are the DATA set (0 through F), and the /T/R/ (ESD) symbol pair. When a receive error occurs, the RXER signal is asserted and arbitrary data is driven onto the RXD[3:0] lines. Should an error be detected during the time that the /J/K/ delimiter is being decoded (bad SSD error), RXER is asserted true and the value '1110' is driven onto the RXD[3:0] lines. Note that the Valid Data signal is not yet asserted when the bad SSD error occurs.

3.1.2.9 100M Receive Data Across the MII/RMII Interface

In MII mode, the 4-bit data nibbles are sent to the MII block. These data nibbles are clocked to the controller at a rate of 25 MHz. The controller samples the data on the rising edge of RXCLK. To ensure that the setup and hold requirements are met, the nibbles are clocked out of the transceiver on the falling edge of RXCLK. RXCLK is the 25 MHz output clock for the MII bus. It is recovered from the received data to clock the RXD bus. If there is no received signal, it is derived from the system reference clock (XTAL1/CLKIN).

When tracking the received data, RXCLK has a maximum jitter of 0.8 ns (provided that the jitter of the input clock, XTAL1/CLKIN, is below 100 ps).

In RMII mode, the 2-bit data nibbles are sent to the RMII block. These data nibbles are clocked to the controller at a rate of 50 MHz. The controller samples the data on the rising edge of XTAL1/CLKIN (REF_CLK). To ensure that the setup and hold requirements are met, the nibbles are clocked out of the transceiver on the falling edge of XTAL1/CLKIN (REF_CLK).

3.1.3 10BASE-T Transmit

Data to be transmitted comes from the MAC layer controller. The 10BASE-T transmitter receives 4-bit nibbles from the MII at a rate of 2.5 MHz and converts them to a 10 Mbps serial data stream. The data stream is then Manchester-encoded and sent to the analog transmitter, which drives a signal onto the twisted pair via the external magnetics.

The 10M transmitter uses the following blocks:

- MII (digital)
- TX 10M (digital)
- 10M Transmitter (analog)
- 10M PLL (analog)

3.1.3.1 10M Transmit Data Across the MII/RMII Interface

The MAC controller drives the transmit data onto the TXD bus. For MII, when the controller has driven TXEN high to indicate valid data, the data is latched by the MII block on the rising edge of TXCLK. The data is in the form of 4-bit wide 2.5 MHz data. For RMII, TXD[1:0] shall transition synchronously with respect to REF_CLK. When TXEN is asserted, TXD[1:0] are accepted for transmission by the device. TXD[1:0] shall be "00" to indicate idle when TXEN is deasserted. Values of TXD[1:0] other than "00" when TXEN is deasserted are reserved for out-of-band signalling (to be defined). Values other than "00" on TXD[1:0] while TXEN is deasserted shall be ignored by the device. TXD[1:0] shall provide valid data for each REF_CLK period while TXEN is asserted.

In order to comply with legacy 10BASE-T MAC/Controllers, in half-duplex mode the transceiver loops back the transmitted data, on the receive path. This does not confuse the MAC/Controller since the COL signal is not asserted during this time. The transceiver also supports the SQE (Heartbeat) signal. See [Section 3.8.9, "Collision Detect," on page 55](#), for more details.

3.1.3.2 Manchester Encoding

The 4-bit wide data is sent to the 10M TX block. The nibbles are converted to a 10 Mbps serial NRZI data stream. The 10M PLL locks onto the external clock or internal oscillator and produces a 20 MHz clock. This is used to Manchester encode the NRZ data stream. When no data is being transmitted (TXEN is low), the 10M TX block outputs Normal Link Pulses (NLPs) to maintain communications with the remote link partner.

3.1.3.3 10M Transmit Drivers

The Manchester-encoded data is sent to the analog transmitter where it is shaped and filtered before being driven out as a differential signal across the TXP and TXN outputs.

3.1.4 10BASE-T Receive

The 10BASE-T receiver gets the Manchester- encoded analog signal from the cable via the magnetics. It recovers the receive clock from the signal and uses this clock to recover the NRZI data stream. This 10M serial data is converted to 4-bit data nibbles which are passed to the controller via MII at a rate of 2.5 MHz.

This 10M receiver uses the following blocks:

- Filter and SQUELCH (analog)
- 10M PLL (analog)
- RX 10M (digital)
- MII (digital)

Datasheet**3.1.4.1 10M Receive Input and Squelch**

The Manchester signal from the cable is fed into the transceiver (on inputs RXP and RXN) via 1:1 ratio magnetics. It is first filtered to reduce any out-of-band noise. It then passes through a SQUELCH circuit. The SQUELCH is a set of amplitude and timing comparators that normally reject differential voltage levels below 300 mV and detect and recognize differential voltages above 585 mV.

3.1.4.2 Manchester Decoding

The output of the SQUELCH goes to the 10M RX block where it is validated as Manchester encoded data. The polarity of the signal is also checked. If the polarity is reversed (local RXP is connected to RXN of the remote partner and vice versa), the condition is identified and corrected. The reversed condition is indicated by the XPOL bit of the [Special Control/Status Indications Register](#). The 10M PLL is locked onto the received Manchester signal, from which the 20 MHz clock is generated. Using this clock, the Manchester encoded data is extracted and converted to a 10 MHz NRZI data stream. It is then converted from serial to 4-bit wide parallel data.

The 10M RX block also detects valid 10BASE-T IDLE signals - Normal Link Pulses (NLPs) - to maintain the link.

3.1.4.3 10M Receive Data Across the MII/RMII Interface

For MII, the 4-bit data nibbles are sent to the MII block. In MII mode, these data nibbles are valid on the rising edge of the 2.5 MHz RXCLK.

For RMII, the 2-bit data nibbles are sent to the RMII block. In RMII mode, these data nibbles are valid on the rising edge of the RMII REF_CLK.

Note: RXDV goes high with the SFD.

3.1.4.4 Jabber Detection

Jabber is a condition in which a station transmits for a period of time longer than the maximum permissible packet length, usually due to a fault condition, which results in holding the TXEN input for a long period. Special logic is used to detect the jabber state and abort the transmission to the line within 45 ms. Once TXEN is deasserted, the logic resets the jabber condition.

As shown in [Section 4.2.2, "Basic Status Register," on page 71](#), the [Jabber Detect](#) bit indicates that a jabber condition was detected.

3.2 Auto-Negotiation

The purpose of the auto-negotiation function is to automatically configure the transceiver to the optimum link parameters based on the capabilities of its link partner. Auto-negotiation is a mechanism for exchanging configuration information between two link-partners and automatically selecting the highest performance mode of operation supported by both sides. Auto-negotiation is fully defined in clause 28 of the IEEE 802.3 specification.

Once auto-negotiation has completed, information about the resolved link can be passed back to the controller via the Serial Management Interface (SMI). The results of the negotiation process are reflected in the [Speed Indication](#) bits of the [PHY Special Control/Status Register](#), as well as in the [Auto Negotiation Link Partner Ability Register](#). The auto-negotiation protocol is a purely physical layer activity and proceeds independently of the MAC controller.

The advertised capabilities of the transceiver are stored in the [Auto Negotiation Advertisement Register](#). The default advertised by the transceiver is determined by user-defined on-chip signal options.

The following blocks are activated during an auto-negotiation session:

- Auto-negotiation (digital)
- 100M ADC (analog)
- 100M PLL (analog)
- 100M equalizer/BLW/clock recovery (DSP)
- 10M SQUELCH (analog)
- 10M PLL (analog)
- 10M Transmitter (analog)

When enabled, auto-negotiation is started by the occurrence of one of the following events:

- Hardware reset
- Software reset
- Power-down reset
- Link status down
- Setting the [Restart Auto-Negotiate](#) bit of the [Basic Control Register](#)

On detection of one of these events, the transceiver begins auto-negotiation by transmitting bursts of Fast Link Pulses (FLP), which are bursts of link pulses from the 10M transmitter. They are shaped as Normal Link Pulses and can pass uncorrupted down CAT-3 or CAT-5 cable. A Fast Link Pulse Burst consists of up to 33 pulses. The 17 odd-numbered pulses, which are always present, frame the FLP burst. The 16 even-numbered pulses, which may be present or absent, contain the data word being transmitted. Presence of a data pulse represents a “1”, while absence represents a “0”.

The data transmitted by an FLP burst is known as a “Link Code Word.” These are defined fully in IEEE 802.3 clause 28. In summary, the transceiver advertises 802.3 compliance in its selector field (the first 5 bits of the Link Code Word). It advertises its technology ability according to the bits set in the [Auto Negotiation Advertisement Register](#).

There are 4 possible matches of the technology abilities. In the order of priority these are:

- 100M Full Duplex (Highest Priority)
- 100M Half Duplex
- 10M Full Duplex
- 10M Half Duplex (Lowest Priority)

If the full capabilities of the transceiver are advertised (100M, Full Duplex), and if the link partner is capable of 10M and 100M, then auto-negotiation selects 100M as the highest performance mode. If the link partner is capable of half and full duplex modes, then auto-negotiation selects full duplex as the highest performance operation.

Once a capability match has been determined, the link code words are repeated with the acknowledge bit set. Any difference in the main content of the link code words at this time will cause auto-negotiation to re-start. Auto-negotiation will also re-start if not all of the required FLP bursts are received.

The capabilities advertised during auto-negotiation by the transceiver are initially determined by the logic levels latched on the MODE[2:0] configuration straps after reset completes. These configuration straps can also be used to disable auto-negotiation on power-up. Refer to [Section 3.7.2, "MODE\[2:0\]: Mode Configuration," on page 40](#) for additional information.

Writing the bits 8 through 5 of the [Auto Negotiation Advertisement Register](#) allows software control of the capabilities advertised by the transceiver. Writing the [Auto Negotiation Advertisement Register](#) does not automatically re-start auto-negotiation. The [Restart Auto-Negotiate](#) bit of the [Basic Control](#)

Datasheet

[Register](#) must be set before the new abilities will be advertised. Auto-negotiation can also be disabled via software by clearing the [Auto-Negotiation Enable](#) bit of the [Basic Control Register](#).

3.2.1 Parallel Detection

If the LAN8740A/LAN8740Ai is connected to a device lacking the ability to auto-negotiate (i.e., no FLPs are detected), it is able to determine the speed of the link based on either 100M MLT-3 symbols or 10M Normal Link Pulses. In this case the link is presumed to be half duplex per the IEEE standard. This ability is known as “Parallel Detection.” This feature ensures interoperability with legacy link partners. If a link is formed via parallel detection, then the [Link Partner Auto-Negotiation Able](#) bit of the [Auto Negotiation Expansion Register](#) is cleared to indicate that the Link Partner is not capable of auto-negotiation. The controller has access to this information via the management interface. If a fault occurs during parallel detection, the [Parallel Detection Fault](#) bit of [Link Partner Auto-Negotiation Able](#) is set.

[Auto Negotiation Link Partner Ability Register](#) is used to store the link partner ability information, which is coded in the received FLPs. If the link partner is not auto-negotiation capable, then the [Auto Negotiation Link Partner Ability Register](#) is updated after completion of parallel detection to reflect the speed capability of the link partner.

3.2.2 Restarting Auto-Negotiation

Auto-negotiation can be restarted at any time by setting the [Restart Auto-Negotiate](#) bit of the [Basic Control Register](#). Auto-negotiation will also restart if the link is broken at any time. A broken link is caused by signal loss. This may occur because of a cable break, or because of an interruption in the signal transmitted by the link partner. Auto-negotiation resumes in an attempt to determine the new link configuration.

If the management entity re-starts auto-negotiation by setting the [Restart Auto-Negotiate](#) bit of the [Basic Control Register](#), the LAN8740A/LAN8740Ai will respond by stopping all transmission/receiving operations. Once the `break_link_timer` is completed in the auto-negotiation state-machine (approximately 1250 ms), auto-negotiation will re-start. In this case, the link partner will have also dropped the link due to lack of a received signal, so it too will resume auto-negotiation.

3.2.3 Disabling Auto-Negotiation

Auto-negotiation can be disabled by setting the [Auto-Negotiation Enable](#) bit of the [Basic Control Register](#) to zero. The device will then force its speed of operation to reflect the information in the [Basic Control Register](#) ([Speed Select](#) bit and [Duplex Mode](#) bit). These bits should be ignored when auto-negotiation is enabled.

3.2.4 Half vs. Full Duplex

Half duplex operation relies on the CSMA/CD (Carrier Sense Multiple Access / Collision Detect) protocol to handle network traffic and collisions. In this mode, the carrier sense signal, CRS, responds to both transmit and receive activity. If data is received while the transceiver is transmitting, a collision results.

In full duplex mode, the transceiver is able to transmit and receive data simultaneously. In this mode, CRS responds only to receive activity. The CSMA/CD protocol does not apply and collision detection is disabled.

3.3 HP Auto-MDIX Support

HP Auto-MDIX facilitates the use of CAT-3 (10BASE-T) or CAT-5 (100BASE-TX) media UTP interconnect cable without consideration of interface wiring scheme. If a user plugs in either a direct connect LAN cable, or a cross-over patch cable, as shown in [Figure 3.4](#), the device's Auto-MDIX transceiver is capable of configuring the TXP/TXN and RXP/RXN pins for correct transceiver operation.

The internal logic of the device detects the TX and RX pins of the connecting device. Since the RX and TX line pairs are interchangeable, special PCB design considerations are needed to accommodate the symmetrical magnetics and termination of an Auto-MDIX design.

The Auto-MDIX function can be disabled via the [AMDIXCTRL](#) bit in the [Special Control/Status Indications Register](#).

Note: When operating in 10BASE-T or 100BASE-TX manual modes, the Auto-MDIX crossover time can be extended via the [Extend Manual 10/100 Auto-MDIX Crossover Time](#) bit of the [EDPD NLP / Crossover Time / EEE Configuration Register](#). Refer to [Section 4.2.12, "EDPD NLP / Crossover Time / EEE Configuration Register,"](#) on [page 82](#) for additional information.

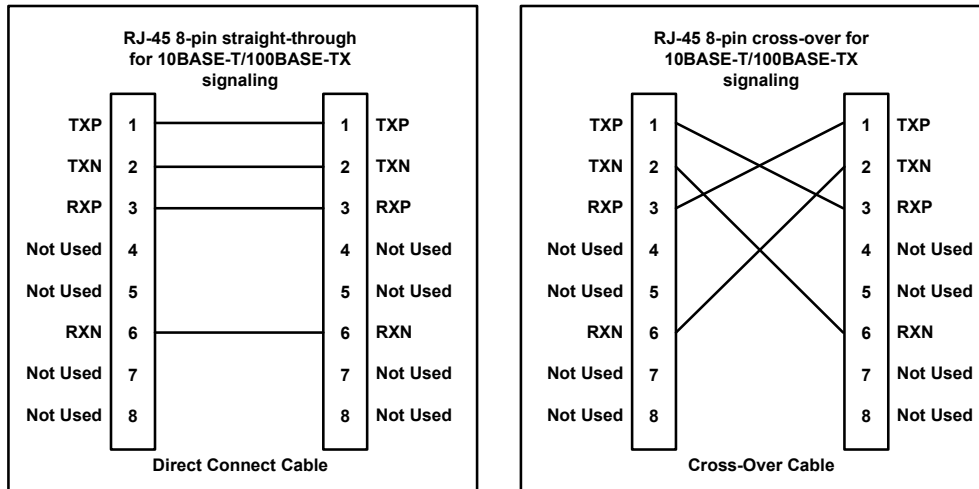

Figure 3.4 Direct Cable Connection vs. Cross-over Cable Connection

3.4 MAC Interface

The MII/RMII block is responsible for communication with the MAC controller. Special sets of handshake signals are used to indicate that valid received/transmitted data is present on the 4 bit receive/transmit bus.

The device must be configured in MII or RMII mode. This is done by specific pin strapping configurations. Refer to [Section 3.4.3, "MII vs. RMII Configuration,"](#) on [page 34](#) for information on pin strapping and how the pins are mapped differently.

Datasheet**3.4.1 MII**

The MII includes 16 interface signals:

- Transmit data - TXD[3:0]
- Transmit strobe - TXEN
- Transmit clock - TXCLK
- Transmit error - TXER/TXD4
- Receive data - RXD[3:0]
- Receive strobe - RXDV
- Receive clock - RXCLK
- Receive error - RXER/RXD4/PHYAD0
- Collision indication - COL
- Carrier sense - CRS

In MII mode, on the transmit path, the transceiver drives the transmit clock, TXCLK, to the controller. The controller synchronizes the transmit data to the rising edge of TXCLK. The controller drives TXEN high to indicate valid transmit data. The controller drives TXER high when a transmit error is detected.

On the receive path, the transceiver drives both the receive data, RXD[3:0], and the RXCLK signal. The controller clocks in the receive data on the rising edge of RXCLK when the transceiver drives RXDV high. The transceiver drives RXER high when a receive error is detected.

3.4.2 RMII

The device supports the low pin count Reduced Media Independent Interface (RMII) intended for use between Ethernet transceivers and switch ASICs. Under IEEE 802.3, an MII comprised of 16 pins for data and control is defined. In devices incorporating many MACs or transceiver interfaces such as switches, the number of pins can add significant cost as the port counts increase. RMII reduces this pin count while retaining a management interface (MDIO/MDC) that is identical to MII.

The RMII interface has the following characteristics:

- It is capable of supporting 10 Mbps and 100 Mbps data rates
- A single clock reference is used for both transmit and receive
- It provides independent 2-bit (di-bit) wide transmit and receive data paths
- It uses LVCMOS signal levels, compatible with common digital CMOS ASIC processes

The RMII includes the following interface signals (1 optional):

- Transmit data - TXD[1:0]
- Transmit strobe - TXEN
- Receive data - RXD[1:0]
- Receive error - RXER (Optional)
- Carrier sense - CRS_DV
- Reference Clock - (RMII references usually define this signal as REF_CLK)

3.4.2.1 CRS_DV - Carrier Sense/Receive Data Valid

The CRS_DV is asserted by the device when the receive medium is non-idle. CRS_DV is asserted asynchronously on detection of carrier due to the criteria relevant to the operating mode. In 10BASE-T mode when squelch is passed, or in 100BASE-TX mode when 2 non-contiguous zeroes in 10 bits are detected, the carrier is said to be detected.

Loss of carrier shall result in the deassertion of CRS_DV synchronous to the cycle of REF_CLK which presents the first di-bit of a nibble onto RXD[1:0] (i.e., CRS_DV is deasserted only on nibble boundaries). If the device has additional bits to be presented on RXD[1:0] following the initial deassertion of CRS_DV, then the device shall assert CRS_DV on cycles of REF_CLK which present the second di-bit of each nibble and de-assert CRS_DV on cycles of REF_CLK which present the first di-bit of a nibble. The result is, starting on nibble boundaries, CRS_DV toggles at 25 MHz in 100 Mbps mode and 2.5 MHz in 10 Mbps mode when CRS ends before RXDV (i.e., the FIFO still has bits to transfer when the carrier event ends). Therefore, the MAC can accurately recover RXDV and CRS.

During a false carrier event, CRS_DV shall remain asserted for the duration of carrier activity. The data on RXD[1:0] is considered valid once CRS_DV is asserted. However, since the assertion of CRS_DV is asynchronous relative to REF_CLK, the data on RXD[1:0] shall be "00" until proper receive signal decoding takes place.

3.4.2.2 Reference Clock (REF_CLK)

The RMII REF_CLK is a continuous clock that provides the timing reference for CRS_DV, RXD[1:0], TXEN, TXD[1:0] and RXER. The device uses REF_CLK as the network clock such that no buffering is required on the transmit data path. However, on the receive data path, the receiver recovers the clock from the incoming data stream, and the device uses elasticity buffering to accommodate for differences between the recovered clock and the local REF_CLK.

Datasheet

3.4.3 MII vs. RMII Configuration

The device must be configured to support the MII or RMII bus for connectivity to the MAC. This configuration is done via the [RMISEL](#) configuration strap. MII or RMII mode selection is configured based on the strapping of the [RMISEL](#) configuration strap as described in [Section 3.7.3, "RMISEL: MII/RMII Mode Configuration," on page 41](#). Additionally, the MII/RMII interface can be disabled (outputs driven low) via the [Interface Disable](#) bit of the [Wakeup Control and Status Register \(WUCSR\)](#).

Most of the MII and RMII pins are multiplexed. [Table 3.2, "MII/RMII Signal Mapping"](#) describes the relationship of the related device pins to the MII and RMII mode signal names.

Table 3.2 MII/RMII Signal Mapping

| PIN NAME | MII MODE | RMII MODE |
|----------------------|---------------|----------------------------------|
| TXD0 | TXD0 | TXD0 |
| TXD1 | TXD1 | TXD1 |
| TXEN | TXEN | TXEN |
| RXER/ RXD4/PHYAD0 | RXER | RXER Note 3.2 |
| COL/CRS_DV/MODE2 | COL | CRS_DV |
| RXD0/MODE0 | RXD0 | RXD0 |
| RXD1/MODE1 | RXD1 | RXD1 |
| TXD2 | TXD2 | Note 3.1 |
| TXD3 | TXD3 | Note 3.1 |
| nINT/TXER/TXD4 | TXER/ TXD4 | |
| CRS | CRS | |
| RXDV | RXDV | |
| RXD2/RMISEL | RXD2 | |
| RXD3/PHYAD2 | RXD3 | |
| TXCLK | TXCLK | |
| RXCLK/PHYAD1 | RXCLK | |
| XTAL1/CLKIN | XTAL1/CLKIN | REF_CLK |

Note 3.1 In RMII mode, this pin needs to be tied to VSS.

Note 3.2 The RXER signal is optional on the RMII bus. This signal is required by the transceiver, but it is optional for the MAC. The MAC can choose to ignore or not use this signal.

3.5 Serial Management Interface (SMI)

The Serial Management Interface is used to control the device and obtain its status. This interface supports registers 0 through 6 as required by clause 22 of the 802.3 standard, as well as “vendor-specific” registers 16 to 31 allowed by the specification. Device registers are detailed in [Chapter 4, "Register Descriptions,"](#) on page 68.

At the system level, SMI provides 2 signals: MDIO and MDC. The MDC signal is an aperiodic clock provided by the Station Management Controller (SMC). MDIO is a bi-directional data SMI input/output signal that receives serial data (commands) from the controller SMC and sends serial data (status) to the SMC. The minimum time between edges of the MDC is 160 ns. There is no maximum time between edges. The minimum cycle time (time between two consecutive rising or two consecutive falling edges) is 400 ns. These modest timing requirements allow this interface to be easily driven by the I/O port of a microcontroller.

The data on the MDIO line is latched on the rising edge of the MDC. The frame structure and timing of the data is shown in [Figure 3.5](#) and [Figure 3.6](#). The timing relationships of the MDIO signals are further described in [Section 5.6.5, "SMI Timing,"](#) on page 136.

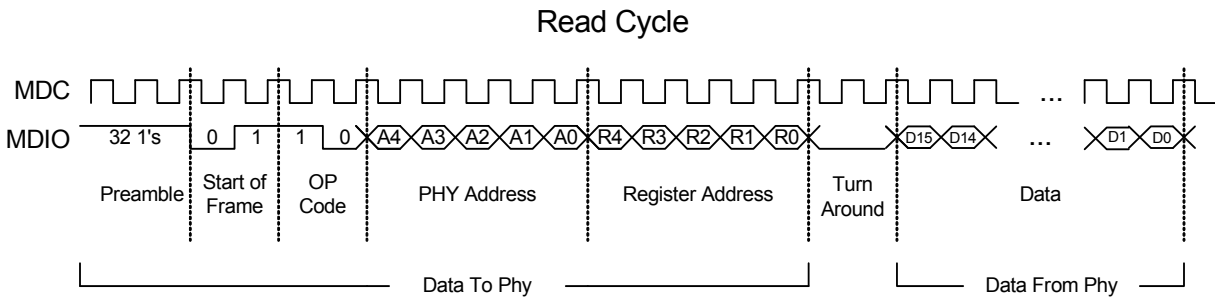

Figure 3.5 MDIO Timing and Frame Structure - READ Cycle

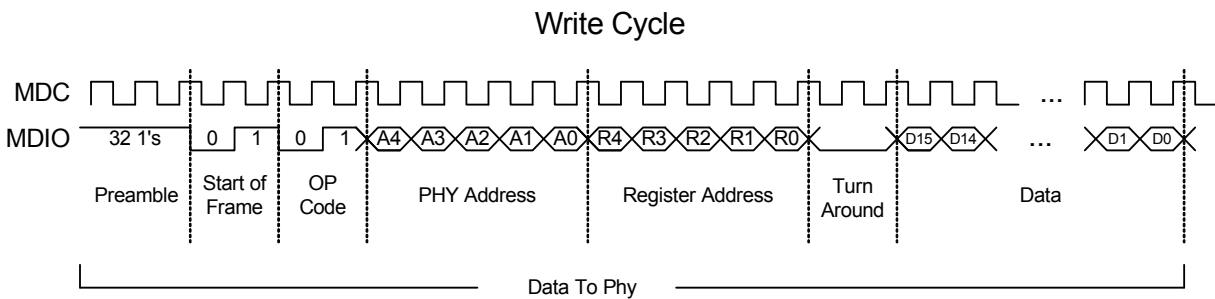

Figure 3.6 MDIO Timing and Frame Structure - WRITE Cycle

3.6 Interrupt Management

The device management interface supports an interrupt capability that is not a part of the IEEE 802.3 specification. This interrupt capability generates an active low asynchronous interrupt signal on the nINT output whenever certain events are detected as setup by the [Interrupt Mask Register](#).

The nINT signal can be selected to output on three different pins:

- **nINT/TXER/TXD4**
(See [Section 3.7.5, "nINTSEL: nINT/TXER/TXD4 Configuration,"](#) on page 42 for configuration information)
- **LED1**
(See [Section 3.8.1, "LEDs,"](#) on page 43 for configuration information)
- **LED2**
(See [Section 3.8.1, "LEDs,"](#) on page 43 for configuration information)

The device's interrupt system provides two modes, a Primary interrupt mode and an Alternative interrupt mode. Both systems will assert the nINT pin low when the corresponding mask bit is set. These modes differ only in how they de-assert the nINT interrupt output. These modes are detailed in the following subsections.

Note: The Primary interrupt mode is the default interrupt mode after a power-up or hard reset. The Alternative interrupt mode requires setup after a power-up or hard reset.

Note: In addition to the main interrupts described in this section, an nPME pin is provided exclusively for WoL specific interrupts. Refer to [Section 3.8.4, "Wake on LAN \(WoL\),"](#) on page 48 for additional information on nPME.

Note: Due to the multiplexing of nINT and TXER on the same pin, when EEE and WoL are both enabled, nINT and/or nPME must be multiplexed on LED1 and/or LED2. Refer to [Section 3.8.1, "LEDs,"](#) on page 43 and [Section 3.8.4, "Wake on LAN \(WoL\),"](#) on page 48 for additional information.

3.6.1 Primary Interrupt System

The Primary interrupt system is the default interrupt mode ([ALTINT](#) bit of the [Mode Control/Status Register](#) is “0”). The Primary interrupt system is always selected after power-up or hard reset. In this mode, to set an interrupt, set the corresponding mask bit in the [Interrupt Mask Register](#) (see [Table 3.3](#)). Then when the event to assert nINT is true, the nINT output will be asserted. When the corresponding event to deassert nINT is true, then the nINT will be de-asserted.

Table 3.3 Interrupt Management Table

| MASK | INTERRUPT SOURCE FLAG | | INTERRUPT SOURCE | | EVENT TO ASSERT nINT | EVENT TO DE-ASSERT nINT |
|------|-----------------------|------------------------------------|------------------|-----------------------------|---|--|
| 30.8 | 29.8 | WoL | 3.32784 .7:4 | nPME | Rising 3.32784.7:4 or'ed together | 3.32784.7:4 or'ed together low or reading register 29 |
| 30.7 | 29.7 | ENERGYON | 17.1 | ENERGYON | Rising 17.1 (Note 3.3) | Falling 17.1 or Reading register 29 |
| 30.6 | 29.6 | Auto-Negotiation complete | 1.5 | Auto-Negotiate Complete | Rising 1.5 | Falling 1.5 or Reading register 29 |
| 30.5 | 29.5 | Remote Fault Detected | 1.4 | Remote Fault | Rising 1.4 | Falling 1.4, or Reading register 1 or Reading register 29 |
| 30.4 | 29.4 | Link Down | 1.2 | Link Status | Falling 1.2 | Reading register 1 or Reading register 29 |
| 30.3 | 29.3 | Auto-Negotiation LP Acknowledge | 5.14 | Acknowledge | Rising 5.14 | Falling 5.14 or Reading register 29 |
| 30.2 | 29.2 | Parallel Detection Fault | 6.4 | Parallel Detection Fault | Rising 6.4 | Falling 6.4 or Reading register 6, or Reading register 29, or Re-Auto Negotiate or Link down |
| 30.1 | 29.1 | Auto-Negotiation Page Received | 6.1 | Page Received | Rising 6.1 | Falling 6.1 or Reading register 6, or Reading register 29, or Re-Auto Negotiate, or Link down. |

Note 3.3 If the mask bit is enabled and nINT has been de-asserted while ENERGYON is still high, nINT will assert for 256 ms, approximately one second after ENERGYON goes low when the Cable is unplugged. To prevent an unexpected assertion of nINT, the ENERGYON interrupt mask should always be cleared as part of the ENERGYON interrupt service routine.

Note: The [ENERGYON](#) bit in the [Mode Control/Status Register](#) is defaulted to a ‘1’ at the start of the signal acquisition process, therefore the [INT7](#) bit in the [Interrupt Mask Register](#) will also read as a ‘1’ at power-up. If no signal is present, then both [ENERGYON](#) and [INT7](#) will clear within a few milliseconds.

Datasheet

3.6.2 Alternate Interrupt System

The Alternate interrupt system is enabled by setting the [ALTINT](#) bit of the [Mode Control/Status Register](#) to “1”. In this mode, to set an interrupt, set the corresponding bit of the in the Mask Register 30, (see [Table 3.4](#)). To Clear an interrupt, either clear the corresponding bit in the [Interrupt Mask Register](#) to deassert the nINT output, or clear the interrupt source, and write a ‘1’ to the corresponding Interrupt Source Flag. Writing a ‘1’ to the Interrupt Source Flag will cause the state machine to check the Interrupt Source to determine if the Interrupt Source Flag should clear or stay as a ‘1’. If the Condition to deassert is true, then the Interrupt Source Flag is cleared and nINT is also deasserted. If the Condition to deassert is false, then the Interrupt Source Flag remains set, and the nINT remains asserted.

For example, setting the [INT7](#) bit in the [Interrupt Mask Register](#) will enable the ENERGYON interrupt. After a cable is plugged in, the [ENERGYON](#) bit in the [Mode Control/Status Register](#) goes active and nINT will be asserted low. To de-assert the nINT interrupt output, either clear the [ENERGYON](#) bit in the [Mode Control/Status Register](#) by removing the cable and then writing a ‘1’ to the [INT7](#) bit in the [Interrupt Mask Register](#), OR clear the INT7 mask (bit 7 of the [Interrupt Mask Register](#)).

Table 3.4 Alternative Interrupt System Management Table

| MASK | INTERRUPT SOURCE FLAG | | INTERRUPT SOURCE | | EVENT TO ASSERT nINT | CONDITION TO DEASSERT | BIT TO CLEAR nINT |
|------|-----------------------|---------------------------------|------------------|--------------------------|--------------------------|-----------------------|-------------------|
| 30.8 | 29.8 | WoL | 3.32784.7:4 | nPME | Rising 3.32784.7:4 or'ed | 3.32784.7:4 all low | 29.8 |
| 30.7 | 29.7 | ENERGYON | 17.1 | ENERGYON | Rising 17.1 | 17.1 low | 29.7 |
| 30.6 | 29.6 | Auto-Negotiation complete | 1.5 | Auto-Negotiate Complete | Rising 1.5 | 1.5 low | 29.6 |
| 30.5 | 29.5 | Remote Fault Detected | 1.4 | Remote Fault | Rising 1.4 | 1.4 low | 29.5 |
| 30.4 | 29.4 | Link Down | 1.2 | Link Status | Falling 1.2 | 1.2 high | 29.4 |
| 30.3 | 29.3 | Auto-Negotiation LP Acknowledge | 5.14 | Acknowledge | Rising 5.14 | 5.14 low | 29.3 |
| 30.2 | 29.2 | Parallel Detection Fault | 6.4 | Parallel Detection Fault | Rising 6.4 | 6.4 low | 29.2 |
| 30.1 | 29.1 | Auto-Negotiation Page Received | 6.1 | Page Received | Rising 6.1 | 6.1 low | 29.1 |

Note: The [ENERGYON](#) bit in the [Mode Control/Status Register](#) is defaulted to a ‘1’ at the start of the signal acquisition process, therefore the [INT7](#) bit in the [Interrupt Mask Register](#) will also read as a ‘1’ at power-up. If no signal is present, then both [ENERGYON](#) and [INT7](#) will clear within a few milliseconds.

3.7 Configuration Straps

Configuration straps allow various features of the device to be automatically configured to user defined values. Configuration straps are latched upon Power-On Reset (POR) and pin reset (nRST). Configuration straps include internal resistors in order to prevent the signal from floating when unconnected. If a particular configuration strap is connected to a load, an external pull-up or pull-down resistor should be used to augment the internal resistor to ensure that it reaches the required voltage level prior to latching. The internal resistor can also be overridden by the addition of an external resistor.

Note: The system designer must guarantee that configuration strap pins meet the timing requirements specified in [Section 5.6.2, "Power-On nRST & Configuration Strap Timing," on page 130](#). If configuration strap pins are not at the correct voltage level prior to being latched, the device may capture incorrect strap values.

Note: When externally pulling configuration straps high, the strap should be tied to VDDIO, except for [REGOFF](#) and [nINTSEL](#) which should be tied to VDD2A.

3.7.1 PHYAD[2:0]: PHY Address Configuration

The [PHYAD\[2:0\]](#) configuration straps are driven high or low to give each PHY a unique address. This address is latched into an internal register at the end of a hardware reset (default = 000b). In a multi-transceiver application (such as a repeater), the controller is able to manage each transceiver via the unique address. Each transceiver checks each management data frame for a matching address in the relevant bits. When a match is recognized, the transceiver responds to that particular frame. The PHY address is also used to seed the scrambler. In a multi-transceiver application, this ensures that the scramblers are out of synchronization and disperses the electromagnetic radiation across the frequency spectrum.

The device's SMI address may be configured using hardware configuration to any value between 0 and 7. The user can configure the PHY address using Software Configuration if an address greater than 7 is required. The PHY address can be written (after SMI communication at some address is established) using the [PHYAD](#) bits of the [Special Modes Register](#). The [PHYAD\[2:0\]](#) configuration straps are multiplexed with other signals as shown in [Table 3.5](#).

Table 3.5 Pin Names for Address Bits

| ADDRESS BIT | PIN NAME |
|-------------|-----------------------------------|
| PHYAD[0] | RXER/RXD4/ PHYAD0 |
| PHYAD[1] | RXCLK/ PHYAD1 |
| PHYAD[2] | RXD3/ PHYAD2 |

Datasheet

3.7.2 MODE[2:0]: Mode Configuration

The MODE[2:0] configuration straps control the configuration of the 10/100 digital block. When the nRST pin is deasserted, the register bit values are loaded according to the MODE[2:0] configuration straps. The 10/100 digital block is then configured by the register bit values. When a soft reset occurs via the [Soft Reset](#) bit of the [Basic Control Register](#), the configuration of the 10/100 digital block is controlled by the register bit values and the MODE[2:0] configuration straps have no affect.

The device's mode may be configured using the hardware configuration straps as summarized in [Table 3.6](#). The user may configure the transceiver mode by writing the SMI registers.

Table 3.6 MODE[2:0] Bus

| <u>MODE[2:0]</u> | MODE DEFINITIONS | DEFAULT REGISTER BIT VALUES | |
|------------------|---|-----------------------------|------------|
| | | REGISTER 0 | REGISTER 4 |
| | | [13,12,10,8] | [8,7,6,5] |
| 000 | 10BASE-T Half Duplex. Auto-negotiation disabled. | 0000 | N/A |
| 001 | 10BASE-T Full Duplex. Auto-negotiation disabled. | 0001 | N/A |
| 010 | 100BASE-TX Half Duplex. Auto-negotiation disabled. CRS is active during Transmit & Receive. | 1000 | N/A |
| 011 | 100BASE-TX Full Duplex. Auto-negotiation disabled. CRS is active during Receive. | 1001 | N/A |
| 100 | 100BASE-TX Half Duplex is advertised. Auto-negotiation enabled. CRS is active during Transmit & Receive. | 1100 | 0100 |
| 101 | Repeater mode. Auto-negotiation enabled. 100BASE-TX Half Duplex is advertised. CRS is active during Receive. | 1100 | 0100 |
| 110 | Power-Down mode. In this mode the transceiver will wake-up in Power-Down mode. The transceiver cannot be used when the <u>MODE[2:0]</u> bits are set to this mode. To exit this mode, the <u>MODE</u> bits in Register 18.7:5 (see Section 4.2.14, "Special Modes Register," on page 84) must be configured to some other value and a soft reset must be issued. | N/A | N/A |
| 111 | All capable. Auto-negotiation enabled. | X10X | 1111 |

The MODE[2:0] hardware configuration pins are multiplexed with other signals as shown in [Table 3.7](#).

Table 3.7 Pin Names for Mode Bits

| MODE BIT | PIN NAME |
|----------|--------------------------|
| MODE[0] | RXD0/ <u>MODE0</u> |
| MODE[1] | RXD1/ <u>MODE1</u> |
| MODE[2] | COL/CRS_DV/ <u>MODE2</u> |

3.7.3 **RMIISEL: MII/RMII Mode Configuration**

MII or RMII mode selection is latched on the rising edge of the internal reset (nRST) based on the strapping of the RMIISEL configuration strap. The default mode is MII (via the internal pull-down resistor). To select RMII mode, pull the RMIISEL configuration strap high with an external resistor to VDDIO.

When the nRST pin is deasserted, the MIIMODE bit of the [Special Modes Register](#) is loaded according to the RMIISEL configuration strap. The mode is reflected in the MIIMODE bit of the [Special Modes Register](#).

Refer to [Section 3.4, "MAC Interface," on page 31](#) for additional information on MII and RMII modes.

3.7.4 **REGOFF: Internal +1.2 V Regulator Configuration**

The incorporation of flexPWR technology provides the ability to disable the internal +1.2 V regulator. When the regulator is disabled, an external +1.2 V must be supplied to the VDDCR pin. Disabling the internal +1.2 V regulator makes it possible to reduce total system power, since an external switching regulator with greater efficiency (versus the internal linear regulator) can be used to provide +1.2 V to the transceiver circuitry.

Note: Because the REGOFF configuration strap shares functionality with the LED1 pin, proper consideration must also be given to the LED polarity. Refer to [Section 3.8.1, "LEDs," on page 43](#) for additional information on the relation between REGOFF and the LED1 polarity.

3.7.4.1 **Disabling the Internal +1.2 V Regulator**

To disable the +1.2 V internal regulator, a pull-up strapping resistor should be connected from the REGOFF configuration strap to VDD2A. At power-on, after both VDDIO and VDD2A are within specification, the transceiver will sample REGOFF to determine whether the internal regulator should turn on. If the pin is sampled at a voltage greater than V_{IH} , then the internal regulator is disabled and the system must supply +1.2 V to the VDDCR pin. The VDDIO voltage must be at least 80% of the operating voltage level (1.44 V when operating at 1.8 V, 2.0 V when operating at 2.5 V, 2.64 V when operating at 3.3 V) before voltage is applied to VDDCR. As described in [Section 3.7.4.2](#), when REGOFF is left floating or connected to VSS, the internal regulator is enabled and the system is not required to supply +1.2 V to the VDDCR pin.

3.7.4.2 **Enabling the Internal +1.2 V Regulator**

The +1.2 V for VDDCR is supplied by the on-chip regulator unless the transceiver is configured for the regulator off mode using the REGOFF configuration strap as described in [Section 3.7.4.1](#). By default, the internal +1.2 V regulator is enabled when REGOFF is floating (due to the internal pull-down resistor). During power-on, if REGOFF is sampled below V_{IL} , then the internal +1.2 V regulator will turn on and operate with power from the VDD2A pin.

Datasheet

3.7.5 **nINTSEL: nINT/TXER/TXD4 Configuration**

The nINT, TXER, and TXD4 functions share a common pin. There are two functional modes for this pin, the TXER/TXD4 mode and nINT (interrupt) mode. The nINTSEL configuration strap is latched at POR and on the rising edge of the nRST. By default, nINTSEL is configured for nINT mode via the internal pull-up resistor.

Note: In order to utilize EEE, the nINT/TXER/TXD4 pin must be configured as TXER/TXD4.

Note: Due to the multiplexing of nINT and TXER on the same pin, when EEE and WoL are both enabled, nINT and/or nPME must be multiplexed on LED1 and/or LED2. Refer to [Section 3.6, "Interrupt Management," on page 36](#) and [Section 3.8.4, "Wake on LAN \(WoL\)," on page 48](#) for additional information.

Note: Because the nINTSEL configuration strap shares functionality with the LED2 pin, proper consideration must also be given to the LED polarity. Refer to [Section 3.8.1.6, "nINTSEL and LED2 Polarity Selection," on page 47](#) for additional information on the relation between nINTSEL and the LED2 polarity.

3.8 Miscellaneous Functions

3.8.1 LEDs

Two LED signals are provided as a convenient means to indicate the transceiver's mode of operation or be used as nINT or nPME signals. The LED1 and LED2 pin functions are configurable via the [LED1 Function Select](#) and [LED2 Function Select](#) bits of the [Wakeup Control and Status Register \(WUCSR\)](#), respectively. When used as an LED indicator, the LED signals are either active high or active low as described in [Section 3.8.1.5, "REGOFF and LED1 Polarity Selection," on page 46](#) and [Section 3.8.1.6, "nINTSEL and LED2 Polarity Selection," on page 47](#). For additional information on nINT, refer to [Section 3.6, "Interrupt Management," on page 36](#). For additional information on nPME, refer to [Section 3.8.4, "Wake on LAN \(WoL\)," on page 48](#).

When configured in the default Link/Activity mode, the LED1 output is driven active whenever the device detects a valid link, and blinks when CRS is active (high) indicating activity.

When configured in the default Link Speed mode, the LED2 output is driven active when the operating speed is 100 Mbps. This LED will go inactive when the operating speed is 10 Mbps or during line isolation.

Note: When pulling the LED1 and LED2 pins high, they must be tied to VDD2A, **NOT** VDDIO.

Note: Due to the multiplexing of nINT and TXER on the same pin, when EEE and WoL are both enabled, nINT and/or nPME must be multiplexed on LED1 and/or LED2. Refer to [Section 3.6, "Interrupt Management," on page 36](#) and [Section 3.8.4, "Wake on LAN \(WoL\)," on page 48](#) for additional information.

3.8.1.1 LED1/nINT/nPME Usage with Internal Regulator Disabled (REGOFF High)

When the LED1/nINT/nPME/REGOFF pin is high during reset, the internal regulator is disabled. After the deassertion of reset, this pin will first function as LED1 (Link Activity). Upon configuration, it can function as nINT or nPME. [Figure 3.7](#) illustrates the steps required to program the LED1 pin as nINT or nPME with the internal regulator disabled.

In this configuration, it is possible for an LED to be connected to this pin while it function as nINT or nPME during the WoL state. Since the polarity to turn on the LED is active low, the Link Activity LED will not be lit while waiting for a WoL event.

Note: Refer to [Section 3.7.4, "REGOFF: Internal +1.2 V Regulator Configuration," on page 41](#) for additional information on the REGOFF configuration strap.

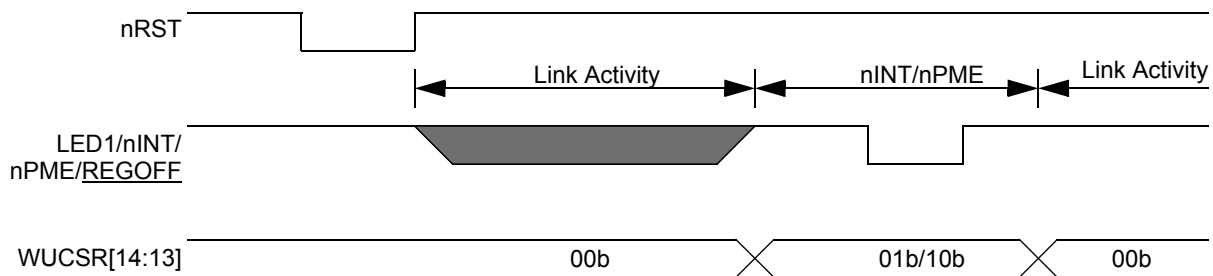

Figure 3.7 LED1/nINT/nPME/REGOFF with Internal Regulator Disabled

Datasheet

3.8.1.2 LED1/nINT/nPME Usage with Internal Regulator Enabled (REGOFF Low)

When the LED1/nINT/nPME/REGOFF pin is low during reset, the internal regulator is enabled. After the deassertion of reset, this pin will first function as LED1 (Link Activity). Upon configuration, it can function as nINT or nPME. [Figure 3.8](#) illustrates the steps required to program the LED1 pin as nINT or nPME with the internal regulator enabled.

In this configuration, it is recommended not to connect an LED to this pin. Because this pin is active high, the LED will be lit while waiting for a WoL event.

Note: Refer to [Section 3.7.4, "REGOFF: Internal +1.2 V Regulator Configuration,"](#) on page 41 for additional information on the REGOFF configuration strap.

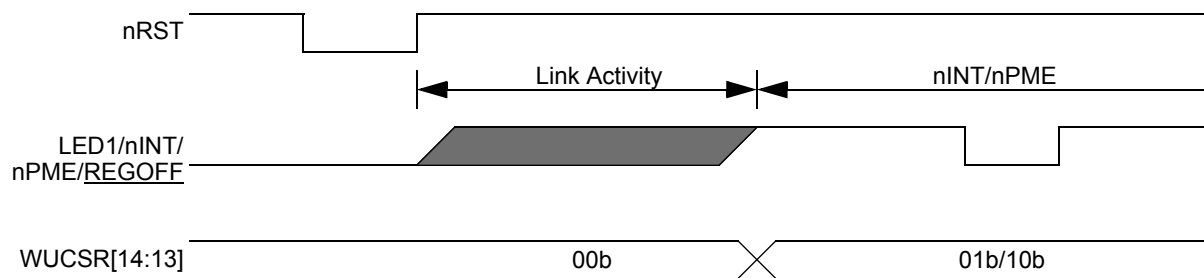

Figure 3.8 LED1/nINT/nPME/REGOFF with Internal Regulator Enabled

3.8.1.3 LED2/nINT/nPME Usage with nINTSEL Enabled

When the LED2/nINT/nPME/nINTSEL pin is high during reset, the nINT/TXER/TXD4 pin is configured to function as nINT. After the deassertion of reset, this pin will first function as LED2 (Link Speed). Upon configuration, it can function as nPME. It is also possible to configure LED2 as nINT although this would duplicate the function of the nINT/TXER/TXD4 pin. [Figure 3.9](#) illustrates the steps required to program the LED2 pin as nINT or nPME with nINTSEL enabled.

In this configuration, it is possible for an LED be connected to this pin while it functions as nINT or nPME during a WoL state. Since the polarity to light the LED is active low, the Link Speed LED will not be lit while waiting for a WoL event.

To provide further flexibility, LED2 can be reconfigured as Link Activity by writing 11b to the [LED2 Function Select](#) field of the [Wakeup Control and Status Register \(WUCSR\)](#). This allows LED2 to function as Link Activity when LED1 cannot be configured as Link Activity. Link Speed can be easily implemented on the microcontroller using GPIO.

Note: Refer to [Section 3.7.5, "nINTSEL: nINT/TXER/TXD4 Configuration,"](#) on page 42 for additional information on the nINTSEL configuration strap.

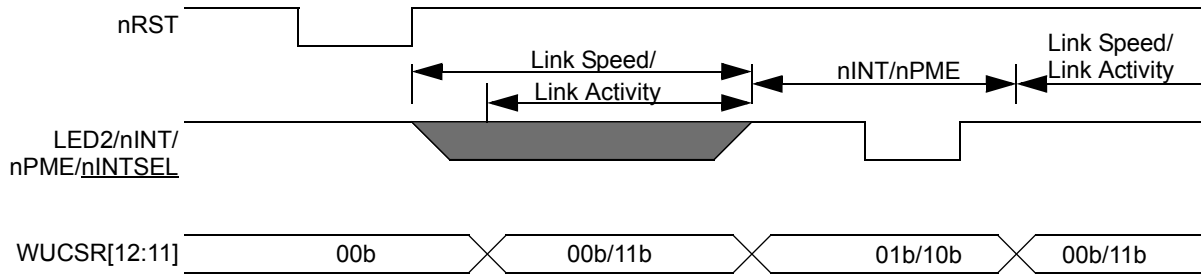

Figure 3.9 LED2/nINT/nPME with nINTSEL Enabled

3.8.1.4 LED2/nINT/nPME Usage with nINTSEL Disabled

When the LED2/nINT/nPME/nINTSEL pin is low during reset, the nINT/TXER/TXD4 pin is configured to function as TXER/TXD4. After the deassertion of reset, this pin will first function as LED2. Upon configuration, it can function as nINT or nPME. Figure 3.10 illustrates the steps required to program the LED2 pin as nINT or nPME with nINTSEL disabled.

In this configuration, it is not recommended to connect an LED to this pin. Because this pin is active high, the LED will be lit while waiting for a WoL event.

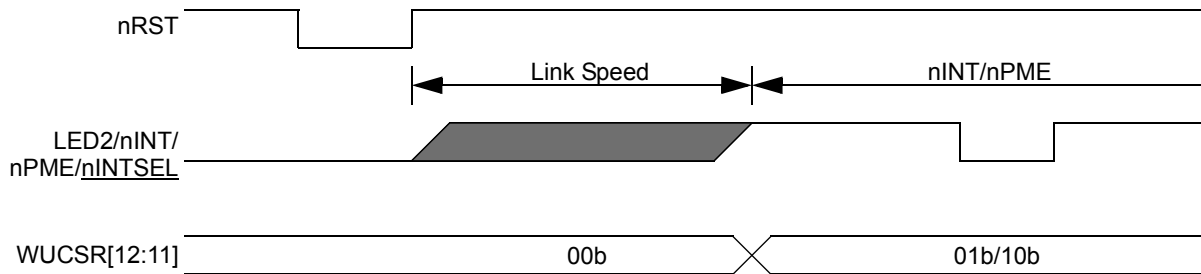

Figure 3.10 LED2/nINT/nPME with nINTSEL Disabled

Datasheet

3.8.1.5 REGOFF and LED1 Polarity Selection

The REGOFF configuration strap is shared with the LED1 pin. The LED1 output will automatically change polarity based on the presence of an external pull-up resistor. If the LED1 pin is pulled high to VDD2A by an external pull-up resistor to select a logical high for REGOFF, then the LED1 output will be active low. If the LED1 pin is pulled low by the internal pull-down resistor to select a logical low for REGOFF, the LED1 output will then be an active high output. [Figure 3.11](#) details the LED1 polarity for each REGOFF configuration.

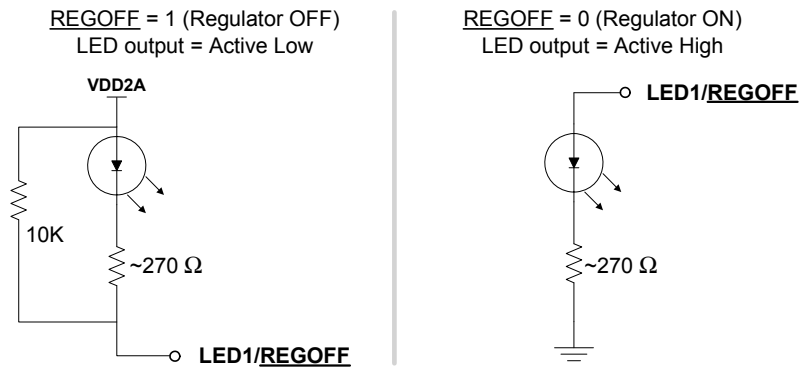

Figure 3.11 LED1/REGOFF Polarity Configuration

Note: Refer to [Section 3.7.4, "REGOFF: Internal +1.2 V Regulator Configuration,"](#) on [page 41](#) for additional information on the REGOFF configuration strap.

3.8.1.6 nINTSEL and LED2 Polarity Selection

The nINTSEL configuration strap is shared with the LED2 pin. The LED2 output will automatically change polarity based on the presence of an external pull-down resistor. If the LED2 pin is pulled high to VDD2A to select a logical high for nINTSEL, then the LED2 output will be active low. If the LED2 pin is pulled low by an external pull-down resistor to select a logical low for nINTSEL, the LED2 output will then be an active high output. Figure 3.12 details the LED2 polarity for each nINTSEL configuration.

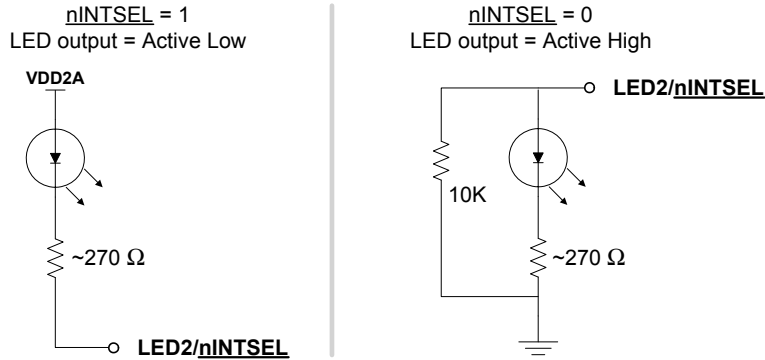

Figure 3.12 LED2/nINTSEL Polarity Configuration

Note: Refer to Section 3.7.5, "nINTSEL: nINT/TXER/TXD4 Configuration," on page 42 for additional information on the nINTSEL configuration strap.

3.8.2 Variable Voltage I/O

The device's digital I/O pins are variable voltage, allowing them to take advantage of low power savings from shrinking technologies. These pins can operate from a low I/O voltage of +1.8 V up to +3.3 V. The applied I/O voltage must maintain its value with a tolerance of $\pm 10\%$. Varying the voltage up or down after the transceiver has completed power-on reset can cause errors in the transceiver operation. Refer to Chapter 5, "Operational Characteristics," on page 124 for additional information.

Note: Input signals must not be driven high before power is applied to the device.

3.8.3 Power-Down Modes

There are two device power-down modes: General Power-Down Mode and Energy Detect Power-Down Mode. These modes are described in the following subsections.

3.8.3.1 General Power-Down

This power-down mode is controlled via the Power Down bit of the Basic Control Register. In this mode, the entire transceiver (except the management interface) is powered-down and remains in this mode as long as the Power Down bit is "1". When the Power Down bit is cleared, the transceiver powers up and is automatically reset.

Datasheet

3.8.3.2 Energy Detect Power-Down (EDPD)

This power-down mode is activated by setting the [EDPWRDOWN](#) bit of the [Mode Control/Status Register](#). In this mode, when no energy is present on the line the transceiver is powered down (except for the management interface, the SQUELCH circuit, and the ENERGYON logic). The ENERGYON logic is used to detect the presence of valid energy from 100BASE-TX, 10BASE-T, or Auto-negotiation signals.

In this mode, when the [ENERGYON](#) bit of the [Mode Control/Status Register](#) is low, the transceiver is powered-down and nothing is transmitted. When energy is received via link pulses or packets, the [ENERGYON](#) bit goes high and the transceiver powers-up. The device automatically resets into the state prior to power-down and asserts the nINT interrupt if the ENERGYON interrupt is enabled in the [Interrupt Mask Register](#). The first and possibly the second packet to activate ENERGYON may be lost.

When the [EDPWRDOWN](#) bit of the [Mode Control/Status Register](#) is low, energy detect power-down is disabled.

When in EDPD mode, the device's NLP characteristics may be modified. The device can be configured to transmit NLPs in EDPD via the [EDPD TX NLP Enable](#) bit of the [EDPD NLP / Crossover Time / EEE Configuration Register](#). When enabled, the TX NLP time interval is configurable via the [EDPD TX NLP Interval Timer Select](#) field of the [EDPD NLP / Crossover Time / EEE Configuration Register](#). When in EDPD mode, the device can also be configured to wake on the reception of one or two NLPs. Setting the [EDPD RX Single NLP Wake Enable](#) bit of the [EDPD NLP / Crossover Time / EEE Configuration Register](#) will enable the device to wake on reception of a single NLP. If the [EDPD RX Single NLP Wake Enable](#) bit is cleared, the maximum interval for detecting reception of two NLPs to wake from EDPD is configurable via the [EDPD RX NLP Max Interval Detect Select](#) field of the [EDPD NLP / Crossover Time / EEE Configuration Register](#).

3.8.4 Wake on LAN (WoL)

The device supports PHY layer WoL event detection of Perfect DA, Broadcast, Magic Packet, and Wakeup frames. The WoL detection can be configured to assert the nINT interrupt pin or nPME pin, providing a mechanism for a system in sleep mode to return to an operational state when a WoL event occurs. This feature is particularly useful in addressing unnecessary waking of the main SoC in designs where the Ethernet MAC is integrated into the SoC.

Each type of supported wake event (Perfect DA, Broadcast, Magic Packet, or Wakeup frames) may be individually enabled via [Perfect DA Wakeup Enable \(PFDA_EN\)](#), [Broadcast Wakeup Enable \(BCST_EN\)](#), [Magic Packet Enable \(MPEN\)](#), and [Wakeup Frame Enable \(WUEN\)](#) bits of the [Wakeup Control and Status Register \(WUCSR\)](#), respectively. Two methods are provided for indicating a WoL event to an external device: nINT and nPME.

The nINT pin may be used to indicate WoL interrupt events by setting bit 8 (WoL) of the [Interrupt Mask Register](#). Once enabled, any received packet that matches the condition(s) configured in the [Wakeup Control and Status Register \(WUCSR\)](#) will assert nINT until the interrupt is cleared. When using nINT to indicate a WoL interrupt, the pin may be shared with other non-WoL interrupt events, as configured via the [Interrupt Mask Register](#). While waiting for a WoL event to occur, it is possible that other interrupts may be triggered. To prevent such conditions, all other interrupts shall be masked by system software, or the alternative nPME pin may be used. Refer to [Section 3.6, "Interrupt Management," on page 36](#) for additional nINT information.

Alternatively, the nPME pin may be used to independently indicate WoL interrupt events. The nPME signal can be configured to output on any of the following pins:

- [LED1/nINT/nPME/nREGOFF](#)
- [LED2/nINT/nPME/nINTSEL](#)
- [RXD2/nPME/RMIISEL](#) (Refer to [Section 3.7.5, "nINTSEL: nINT/TXER/TXD4 Configuration"](#) for configuration information)

The LED1/nINT/nPME/nREGOFF or LED2/nINT/nPME/nINTSEL pin can be configured to function as nPME by configuring the LED1 Function Select or LED2 Function Select bits of the Wakeup Control and Status Register (WUCSR) to 10b, respectively. The RXD2/nPME/RMIISEL pin can be configured to function as nPME by setting the RXD2/RMIISEL Function Select bit of the Wakeup Control and Status Register (WUCSR). The RXD2/nPME/RMIISEL pin can only be used as nPME when in RMII mode. Once the nPME pin is enabled, any received packet that matches the condition(s) configured in the Wakeup Control and Status Register (WUCSR) will assert nPME until WUCSR bits 7:4 are cleared by the system software. However, in some applications it may be desirable for nPME to self clear. When the nPME Self Clear bit of the Wakeup Control and Status Register (WUCSR) is set, the nPME pin will clear after the time configured in the Miscellaneous Configuration Register (MCFGR).

Upon a WoL event, further resolution on the source of the event can be obtained by examining the Perfect DA Frame Received (PFDA_FR), Broadcast Frame Received (BCAST_FR), Magic Packet Received (MPR), and Remote Wakeup Frame Received (WUFR) status bits in the Wakeup Control and Status Register (WUCSR).

Note: Due to the multiplexing of nINT and TXER on the same pin, when EEE and WoL are both enabled, nINT and/or nPME must be multiplexed on LED1 and/or LED2.

The Wakeup Control and Status Register (WUCSR) also provides a WoL Configured bit, which may be set by software after all WoL registers are configured. Because all WoL related registers are not affected by software resets, software can poll the WoL Configured bit to ensure all WoL registers are fully configured. This allows the software to skip reprogramming of the WoL registers after reboot due to a WoL event.

The following subsections detail each type of WoL event. For additional information on the main system interrupts, refer to Section 3.6, "Interrupt Management," on page 36.

3.8.4.1 Perfect DA (Destination Address) Detection

When enabled, the Perfect DA detection mode allows the triggering of the nINT or nPME pin when a frame with the destination address matching the address stored in the MAC Receive Address A Register (RX_ADDRA), MAC Receive Address B Register (RX_ADDRB), and MAC Receive Address C Register (RX_ADDRRC) is received. The frame must also pass the FCS and packet length check.

As an example, the Host system must perform the following steps to enable the device to assert nINT on detection of a Perfect DA WoL event:

1. Set the desired MAC address to cause the wake event in the MAC Receive Address A Register (RX_ADDRA), MAC Receive Address B Register (RX_ADDRB), and MAC Receive Address C Register (RX_ADDRRC).
2. Set the Perfect DA Wakeup Enable (PFDA_EN) bit of the Wakeup Control and Status Register (WUCSR) to enable Perfect DA detection.
3. Set bit 8 (WoL event indicator) in the Interrupt Mask Register to enable WoL events to trigger assertion of the nINT interrupt pin.

When a match is triggered, the nINT interrupt pin will be asserted, bit 8 of the Interrupt Source Flag Register will be set, and the Perfect DA Frame Received (PFDA_FR) bit of the Wakeup Control and Status Register (WUCSR) will be set.

Note: Alternatively, the LED1/nINT/nPME, LED2/nINT/nPME, or RXD2/nPME pin can be used to indicate a WoL event. Refer to Section 3.8.4, "Wake on LAN (WoL)" for additional information.

Datasheet

3.8.4.2 Broadcast Detection

When enabled, the Broadcast detection mode allows the triggering of the nINT or nPME pin when a frame with the destination address value of FF FF FF FF FF FF is received. The frame must also pass the FCS and packet length check.

As an example, the Host system must perform the following steps to enable the device to assert nINT on detection of a Broadcast WoL event:

1. Set the [Broadcast Wakeup Enable \(BCST_EN\)](#) bit of the [Wakeup Control and Status Register \(WUCSR\)](#) to enable Broadcast detection.
2. Set bit 8 (WoL event indicator) in the [Interrupt Mask Register](#) to enable WoL events to trigger assertion of the nINT interrupt pin.

When a match is triggered, the nINT interrupt pin will be asserted, bit 8 of the [Interrupt Source Flag Register](#) will be set, and the [Broadcast Frame Received \(BCAST_FR\)](#) bit of the [Wakeup Control and Status Register \(WUCSR\)](#) will be set.

Note: Alternatively, the LED1/nINT/nPME, LED2/nINT/nPME, or RXD2/nPME pin can be used to indicate a WoL event. Refer to [Section 3.8.4, "Wake on LAN \(WoL\)"](#) for additional information.

3.8.4.3 Magic Packet Detection

When enabled, the Magic Packet detection mode allows the triggering of the nINT or nPME pin when a Magic Packet frame is received. A Magic Packet is a frame addressed to the device - either a unicast to the programmed address, or a broadcast - which contains the pattern 48'h FF_FF_FF_FF_FF_FF after the destination and source address field, followed by 16 repetitions of the desired MAC address (loaded into the [MAC Receive Address A Register \(RX_ADDRA\)](#), [MAC Receive Address B Register \(RX_ADDRB\)](#), and [MAC Receive Address C Register \(RX_ADDR C\)](#)) without any breaks or interruptions. In case of a break in the 16 address repetitions, the logic scans for the 48'h FF_FF_FF_FF_FF_FF pattern again in the incoming frame. The 16 repetitions may be anywhere in the frame but must be preceded by the synchronization stream. The frame must also pass the FCS check and packet length checking.

As an example, if the desired address is 00h 11h 22h 33h 44h 55h, then the logic scans for the following data sequence in an Ethernet frame:

```

Destination Address Source Address .....FF FF FF FF FF FF
00 11 22 33 44 55 00 11 22 33 44 55 00 11 22 33 44 55 00 11 22 33 44 55
00 11 22 33 44 55 00 11 22 33 44 55 00 11 22 33 44 55 00 11 22 33 44 55
00 11 22 33 44 55 00 11 22 33 44 55 00 11 22 33 44 55 00 11 22 33 44 55
00 11 22 33 44 55 00 11 22 33 44 55 00 11 22 33 44 55 00 11 22 33 44 55
...FCS
    
```

As an example, the Host system must perform the following steps to enable the device to assert nINT on detection of a Magic Packet WoL event:

1. Set the desired MAC address to cause the wake event in the [MAC Receive Address A Register \(RX_ADDRA\)](#), [MAC Receive Address B Register \(RX_ADDRB\)](#), and [MAC Receive Address C Register \(RX_ADDR_C\)](#).
2. Set the [Magic Packet Enable \(MPEN\)](#) bit of the [Wakeup Control and Status Register \(WUCSR\)](#) to enable Magic Packet detection.
3. Set bit 8 (WoL event indicator) in the [Interrupt Mask Register](#) to enable WoL events to trigger assertion of the nINT interrupt pin.

When a match is triggered, the nINT interrupt pin will be asserted, bit 8 of the [Interrupt Source Flag Register](#) will be set, and the [Magic Packet Received \(MPR\)](#) bit of the [Wakeup Control and Status Register \(WUCSR\)](#) will be set.

Note: Alternatively, the LED1/nINT/nPME, LED2/nINT/nPME, or RXD2/nPME pin can be used to indicate a WoL event. Refer to [Section 3.8.4, "Wake on LAN \(WoL\)"](#) for additional information.

3.8.4.4 Wakeup Frame Detection

When enabled, the Wakeup Frame detection mode allows the triggering of the nINT or nPME pin when a pre-programmed Wakeup Frame is received. Wakeup Frame detection provides a way for system designers to detect a customized pattern within a packet via a programmable wake-up frame filter. The filter has a 128-bit byte mask that indicates which bytes of the frame should be compared by the detection logic. A CRC-16 is calculated over these bytes. The result is then compared with the filter's respective CRC-16 to determine if a match exists. When a wake-up pattern is received, the [Remote Wakeup Frame Received \(WUFR\)](#) bit of the [Wakeup Control and Status Register \(WUCSR\)](#) is set.

If enabled, the filter can also include a comparison between the frame's destination address and the address specified in the [MAC Receive Address A Register \(RX_ADDRA\)](#), [MAC Receive Address B Register \(RX_ADDRB\)](#), and [MAC Receive Address C Register \(RX_ADDR_C\)](#). The specified address can be a unicast or a multicast. If address matching is enabled, only the programmed unicast or multicast address will be considered a match. Non-specific multicast addresses and the broadcast address can be separately enabled. The address matching results are logically OR'd (i.e., specific address match result OR any multicast result OR broadcast result).

Whether or not the filter is enabled and whether the destination address is checked is determined by configuring the [Wakeup Filter Configuration Register A \(WUF_CFGA\)](#). Before enabling the filter, the application program must provide the detection logic with the sample frame and corresponding byte mask. This information is provided by writing the [Wakeup Filter Configuration Register A \(WUF_CFGA\)](#), [Wakeup Filter Configuration Register B \(WUF_CFGB\)](#), and [Wakeup Filter Byte Mask Registers \(WUF_MASK\)](#). The starting offset within the frame and the expected CRC-16 for the filter is determined by the [Filter Pattern Offset](#) and [Filter CRC-16](#) fields, respectively.

If remote wakeup mode is enabled, the remote wakeup function checks each frame against the filter and recognizes the frame as a remote wakeup frame if it passes the filter's address filtering and CRC value match.

The pattern offset defines the location of the first byte that should be checked in the frame. The byte mask is a 128-bit field that specifies whether or not each of the 128 contiguous bytes within the frame, beginning with the pattern offset, should be checked. If bit j in the byte mask is set, the detection logic checks the byte (pattern offset + j) in the frame, otherwise byte (pattern offset + j) is ignored.

At the completion of the CRC-16 checking process, the CRC-16 calculated using the pattern offset and byte mask is compared to the expected CRC-16 value associated with the filter. If a match occurs, a remote wake-up event is signaled. The frame must also pass the FCS check and packet length checking.

Datasheet

Table 3.8 indicates the cases that produce a wake-up event. All other cases do not generate a wake-up event.

Table 3.8 Wakeup Generation Cases

| FILTER ENABLED | FRAME TYPE | CRC MATCHES | ADDRESS MATCH ENABLED | ANY MCAST ENABLED | BCAST ENABLED | FRAME ADDRESS MATCHES |
|----------------|------------|-------------|-----------------------|-------------------|---------------|-----------------------|
| Yes | Unicast | Yes | No | X | X | X |
| Yes | Unicast | Yes | Yes | X | X | Yes |
| Yes | Multicast | Yes | X | Yes | X | X |
| Yes | Multicast | Yes | Yes | No | X | Yes |
| Yes | Broadcast | Yes | X | X | Yes | X |

As an example, the Host system must perform the following steps to enable the device to assert nINT on detection of a Wakeup Frame WoL event:

Declare Pattern:

1. Update the [Wakeup Filter Byte Mask Registers \(WUF_MASK\)](#) to indicate the valid bytes to match.
2. Calculate the CRC-16 value of valid bytes offline and update the [Wakeup Filter Configuration Register B \(WUF_CFGB\)](#). CRC-16 is calculated as follows:

At the start of a frame, CRC-16 is initialized with the value FFFFh. CRC-16 is updated when the pattern offset and mask indicate the received byte is part of the checksum calculation. The following algorithm is used to update the CRC-16 at that time:

Let:

^ denote the exclusive or operator.

Data [7:0] be the received data byte to be included in the checksum.

CRC[15:0] contain the calculated CRC-16 checksum.

F0 ... F7 be intermediate results, calculated when a data byte is determined to be part of the CRC-16.

Calculate:

$$F0 = \text{CRC}[15] \wedge \text{Data}[0]$$

$$F1 = \text{CRC}[14] \wedge F0 \wedge \text{Data}[1]$$

$$F2 = \text{CRC}[13] \wedge F1 \wedge \text{Data}[2]$$

$$F3 = \text{CRC}[12] \wedge F2 \wedge \text{Data}[3]$$

$$F4 = \text{CRC}[11] \wedge F3 \wedge \text{Data}[4]$$

$$F5 = \text{CRC}[10] \wedge F4 \wedge \text{Data}[5]$$

$$F6 = \text{CRC}[09] \wedge F5 \wedge \text{Data}[6]$$

$$F7 = \text{CRC}[08] \wedge F6 \wedge \text{Data}[7]$$

The CRC-32 is updated as follows:

$$\begin{aligned} \text{CRC}[15] &= \text{CRC}[7] \wedge \text{F7} \\ \text{CRC}[14] &= \text{CRC}[6] \\ \text{CRC}[13] &= \text{CRC}[5] \\ \text{CRC}[12] &= \text{CRC}[4] \\ \text{CRC}[11] &= \text{CRC}[3] \\ \text{CRC}[10] &= \text{CRC}[2] \\ \text{CRC}[9] &= \text{CRC}[1] \wedge \text{F0} \\ \text{CRC}[8] &= \text{CRC}[0] \wedge \text{F1} \\ \text{CRC}[7] &= \text{F0} \wedge \text{F2} \\ \text{CRC}[6] &= \text{F1} \wedge \text{F3} \\ \text{CRC}[5] &= \text{F2} \wedge \text{F4} \\ \text{CRC}[4] &= \text{F3} \wedge \text{F5} \\ \text{CRC}[3] &= \text{F4} \wedge \text{F6} \\ \text{CRC}[2] &= \text{F5} \wedge \text{F7} \\ \text{CRC}[1] &= \text{F6} \\ \text{CRC}[0] &= \text{F7} \end{aligned}$$

- Determine the offset pattern with offset 0 being the first byte of the destination address. Update the offset in the [Filter Pattern Offset field of the Wakeup Filter Configuration Register A \(WUF_CFGA\)](#).

Determine Address Matching Conditions:

- Determine the address matching scheme based on [Table 3.8](#) and update the [Filter Broadcast Enable](#), [Filter Any Multicast Enable](#), and [Address Match Enable](#) bits of the [Wakeup Filter Configuration Register A \(WUF_CFGA\)](#) accordingly.
- If necessary (see step 4), set the desired MAC address to cause the wake event in the [MAC Receive Address A Register \(RX_ADDRA\)](#), [MAC Receive Address B Register \(RX_ADDRB\)](#), and [MAC Receive Address C Register \(RX_ADDR_C\)](#).
- Set the [Filter Enable](#) bit of the [Wakeup Filter Configuration Register A \(WUF_CFGA\)](#) to enable the filter.

Enable Wakeup Frame Detection:

- Set the [Wakeup Frame Enable \(WUEN\)](#) bit of the [Wakeup Control and Status Register \(WUCSR\)](#) to enable Wakeup Frame detection.
- Set bit 8 (WoL event indicator) in the [Interrupt Mask Register](#) to enable WoL events to trigger assertion of the nINT interrupt pin.

When a match is triggered, the nINT interrupt pin will be asserted and the [Remote Wakeup Frame Received \(WUFR\)](#) bit of the [Wakeup Control and Status Register \(WUCSR\)](#) will be set. To provide additional visibility to software, the [Filter Triggered](#) bit of the [Wakeup Filter Configuration Register A \(WUF_CFGA\)](#) will be set.

Note: Alternatively, the LED1/nINT/nPME, LED2/nINT/nPME, or RXD2/nPME pin can be used to indicate a WoL event. Refer to [Section 3.8.4, "Wake on LAN \(WoL\)"](#) for additional information.

Datasheet

3.8.5 Energy Efficient Ethernet

The device supports IEEE 802.3az Energy Efficient Ethernet (EEE). The EEE functionality is enabled/disabled via the [PHY Energy Efficient Ethernet Enable \(PHYEEEEEN\)](#) bit of the [EDPD NLP / Crossover Time / EEE Configuration Register](#). Energy Efficient Ethernet is disabled by default. In order for EEE to be utilized, the following conditions must be met:

- The device must be configured in MII mode ([RMIISEL](#) configuration strap low)
- The nINT/TXER/TXD4 pin must be configured as TXER/TXD4 ([nINTSEL](#) configuration strap low)
- EEE functionality must be enabled via the [PHY Energy Efficient Ethernet Enable \(PHYEEEEEN\)](#) bit of the [EDPD NLP / Crossover Time / EEE Configuration Register](#)
- The [100BASE-TX EEE](#) bit of the MMD [EEE Advertisement Register](#) must be set
- The selected MAC and link-partner must support and be configured for EEE operation
- The device and link-partner must link in 100BASE-TX full-duplex mode

The value of the [PHY Energy Efficient Ethernet Enable \(PHYEEEEEN\)](#) bit affects the default values of the following register bits:

- [100BASE-TX EEE](#) bit of the MMD [EEE Capability Register](#)
- [100BASE-TX EEE](#) bit of the MMD [EEE Advertisement Register](#)

Note: EEE cannot be used in RMII mode.

Note: Due to the multiplexing of nINT and TXER on the same pin, when EEE and WoL are both enabled, nINT and/or nPME must be multiplexed on LED1 and/or LED2. Refer to [Section 3.8.1, "LEDs," on page 43](#) and [Section 3.8.4, "Wake on LAN \(WoL\)," on page 48](#) for additional information.

3.8.6 Isolate Mode

The device data paths may be electrically isolated from the MII/RMII interface by setting the [Isolate](#) bit of the [Basic Control Register](#) to "1". In isolation mode, the transceiver does not respond to the TXD, TXEN and TXER inputs, but does respond to management transactions.

Isolation provides a means for multiple transceivers to be connected to the same MII/RMII interface without contention. By default, the transceiver is not isolated (on power-up ([Isolate](#) = 0)).

3.8.7 Resets

The device provides two forms of reset: hardware and software. The device registers are reset by both hardware and software resets. Select register bits, indicated as "NASR" in the register definitions, are not cleared by a software reset. The registers are not reset by the power-down modes described in [Section 3.8.3](#).

Note: For the first 16 μ s after coming out of reset, the MII/RMII interface will run at 2.5 MHz. After this time, it will switch to 25 MHz if auto-negotiation is enabled.

3.8.7.1 Hardware Reset

A hardware reset is asserted by driving the nRST input pin low. When driven, nRST should be held low for the minimum time detailed in [Section 5.6.2, "Power-On nRST & Configuration Strap Timing," on page 130](#) to ensure a proper transceiver reset. During a hardware reset, an external clock **must** be supplied to the XTAL1/CLKIN signal.

Note: A hardware reset (nRST assertion) is required following power-up. Refer to [Section 5.6.2, "Power-On nRST & Configuration Strap Timing,"](#) on page 130 for additional information.

3.8.7.2 Software Reset

A Software reset is activated by setting the [Soft Reset](#) bit of the [Basic Control Register](#) to “1”. All registers bits, except those indicated as “NASR” in the register definitions, are cleared by a Software reset. The [Soft Reset](#) bit is self-clearing. Per the IEEE 802.3u standard, clause 22 (22.2.4.1.1) the reset process will be completed within 0.5 s from the setting of this bit.

3.8.8 Carrier Sense

The carrier sense (CRS) is output on the CRS pin in MII mode, and the CRS_DV pin in RMII mode. CRS is a signal defined by the MII specification in the IEEE 802.3u standard. The device asserts CRS based only on receive activity whenever the transceiver is either in repeater mode or full-duplex mode. Otherwise the transceiver asserts CRS based on either transmit or receive activity.

The carrier sense logic uses the encoded, unscrambled data to determine carrier activity status. It activates carrier sense with the detection of 2 non-contiguous zeros within any 10 bit span. Carrier sense terminates if a span of 10 consecutive ones is detected before a /J/K/ Start-of Stream Delimiter pair. If an SSD pair is detected, carrier sense is asserted until either /T/R/ End-of-Stream Delimiter pair or a pair of IDLE symbols is detected. Carrier is negated after the /T/ symbol or the first IDLE. If /T/ is not followed by /R/, then carrier is maintained. Carrier is treated similarly for IDLE followed by some non-IDLE symbol.

3.8.9 Collision Detect

A collision is the occurrence of simultaneous transmit and receive operations. The COL output is asserted to indicate that a collision has been detected. COL remains active for the duration of the collision. COL is changed asynchronously to both RXCLK and TXCLK. The COL output becomes inactive during full duplex mode.

The COL may be tested by setting the [Collision Test](#) bit of the [Basic Control Register](#) to “1”. This enables the collision test. COL will be asserted within 512 bit times of TXEN rising and will be de-asserted within 4 bit times of TXEN falling.

3.8.10 Link Integrity Test

The device performs the link integrity test as outlined in the IEEE 802.3u (clause 24-15) Link Monitor state diagram. The link status is multiplexed with the 10 Mbps link status to form the [Link Status](#) bit in the [Basic Status Register](#) and to drive the LINK LED (LED1).

The DSP indicates a valid MLT-3 waveform present on the RXP and RXN signals as defined by the ANSI X3.263 TP-PMD standard, to the Link Monitor state-machine, using the internal DATA_VALID signal. When DATA_VALID is asserted, the control logic moves into a Link-Ready state and waits for an enable from the auto-negotiation block. When received, the Link-Up state is entered, and the Transmit and Receive logic blocks become active. Should auto-negotiation be disabled, the link integrity logic moves immediately to the Link-Up state when the DATA_VALID is asserted.

To allow the line to stabilize, the link integrity logic will wait a minimum of 330 ms from the time DATA_VALID is asserted until the Link-Ready state is entered. Should the DATA_VALID input be negated at any time, this logic will immediately negate the Link signal and enter the Link-Down state.

When the 10/100 digital block is in 10BASE-T mode, the link status is derived from the 10BASE-T receiver logic.

Datasheet

3.8.11 Cable Diagnostics

The LAN8740A/LAN8740Ai provides cable diagnostics which allow for open/short and length detection of the Ethernet cable. The cable diagnostics consist of two primary modes of operation:

- [Time Domain Reflectometry \(TDR\) Cable Diagnostics](#)
TDR cable diagnostics enable the detection of open or shorted cabling on the TX or RX pair, as well as cable length estimation to the open/short fault.
- [Matched Cable Diagnostics](#)
Matched cable diagnostics enable cable length estimation on 100 Mbps-linked cables.

Refer to the following sub-sections for details on proper operation of each cable diagnostics mode.

3.8.11.1 Time Domain Reflectometry (TDR) Cable Diagnostics

The LAN8740A/LAN8740Ai provides TDR cable diagnostics which enable the detection of open or shorted cabling on the TX or RX pair, as well as cable length estimation to the open/short fault. To utilize the TDR cable diagnostics, Auto-MDIX and Auto Negotiation must be disabled, and the LAN8740A/LAN8740Ai device must be forced to 100 Mb full-duplex mode. These actions must be performed before setting the [TDR Enable](#) bit in the [TDR Control/Status Register](#). With Auto-MDIX disabled, the TDR will test the TX or RX pair selected by register bit 27.15 ([AMDIXCTRL](#)). Proper cable testing should include a test of each pair. When TDR testing is complete, prior register settings may be restored. [Figure 3.13](#) provides a flow diagram of proper TDR usage.

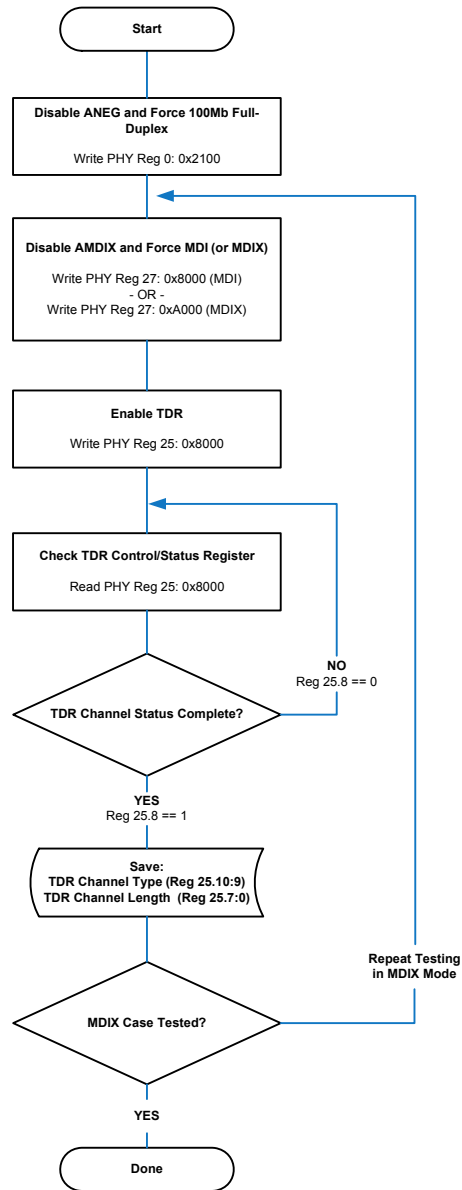

Figure 3.13 TDR Usage Flow Diagram

The TDR operates by transmitting pulses on the selected twisted pair within the Ethernet cable (TX in MDI mode, RX in MDIX mode). If the pair being tested is open or shorted, the resulting impedance discontinuity results in a reflected signal that can be detected by the LAN8740A/LAN8740Ai. The LAN8740A/LAN8740Ai measures the time between the transmitted signal and received reflection and indicates the results in the **TDR Channel Length** field of the **TDR Control/Status Register**. The **TDR Channel Length** field indicates the “electrical” length of the cable, and can be multiplied by the appropriate propagation constant in [Table 3.9](#) to determine the approximate physical distance to the fault.

Datasheet

Note: The TDR function is typically used when the link is inoperable. However, an active link will drop when operating the TDR.

Since the TDR relies on the reflected signal of an improperly terminated cable, there are several factors that can affect the accuracy of the physical length estimate. These include:

1. **Cable Type (CAT 5, CAT5e, CAT6):** The electrical length of each cable type is slightly different due to the twists-per-meter of the internal signal pairs and differences in signal propagation speeds. If the cable type is known, the length estimate can be calculated more accurately by using the propagation constant appropriate for the cable type (see [Table 3.9](#)). In many real-world applications the cable type is unknown, or may be a mix of different cable types and lengths. In this case, use the propagation constant for the “unknown” cable type.
2. **TX and RX Pair:** For each cable type, the EIA standards specify different twist rates (twists-per-meter) for each signal pair within the Ethernet cable. This results in different measurements for the RX and TX pair.
3. **Actual Cable Length:** The difference between the estimated cable length and actual cable length grows as the physical cable length increases, with the most accurate results at less than approximately 100 m.
4. **Open/Short Case:** The Open and Shorted cases will return different TDR Channel Length values (electrical lengths) for the same physical distance to the fault. Compensation for this is achieved by using different propagation constants to calculate the physical length of the cable.

For the Open case, the estimated distance to the fault can be calculated as follows:

$$\text{Distance to Open fault in meters} \cong \text{TDR Channel Length} * P_{\text{OPEN}}$$

Where: P_{OPEN} is the propagation constant selected from [Table 3.9](#)

For the Shorted case, the estimated distance to the fault can be calculated as follows:

$$\text{Distance to Open fault in meters} \cong \text{TDR Channel Length} * P_{\text{SHORT}}$$

Where: P_{SHORT} is the propagation constant selected from [Table 3.9](#)

Table 3.9 TDR Propagation Constants

| TDR PROPAGATION CONSTANT | CABLE TYPE | | | |
|--------------------------|------------|-------|--------|-------|
| | UNKNOWN | CAT 6 | CAT 5E | CAT 5 |
| P_{OPEN} | 0.769 | 0.745 | 0.76 | 0.85 |
| P_{SHORT} | 0.793 | 0.759 | 0.788 | 0.873 |

The typical cable length measurement margin of error for Open and Shorted cases is dependent on the selected cable type and the distance of the open/short from the device. [Table 3.10](#) and [Table 3.11](#) detail the typical measurement error for Open and Shorted cases, respectively.

Table 3.10 Typical Measurement Error for Open Cable (+/- Meters)

| PHYSICAL DISTANCE TO FAULT | SELECTED PROPAGATION CONSTANT | | | |
|----------------------------|-------------------------------|-----------------------|------------------------|-----------------------|
| | $P_{OPEN} =$ Unknown | $P_{OPEN} =$ CAT 6 | $P_{OPEN} =$ CAT 5E | $P_{OPEN} =$ CAT 5 |
| CAT 6 Cable, 0-100 m | 9 | 6 | | |
| CAT 5E Cable, 0-100 m | 5 | | 5 | |
| CAT 5 Cable, 0-100 m | 13 | | | 3 |
| CAT 6 Cable, 101-160 m | 14 | 6 | | |
| CAT 5E Cable, 101-160 m | 8 | | 6 | |
| CAT 5 Cable, 101-160 m | 20 | | | 6 |

Table 3.11 Typical Measurement Error for Shorted Cable (+/- Meters)

| PHYSICAL DISTANCE TO FAULT | SELECTED PROPAGATION CONSTANT | | | |
|----------------------------|-------------------------------|------------------------|-------------------------|------------------------|
| | $P_{SHORT} =$ Unknown | $P_{SHORT} =$ CAT 6 | $P_{SHORT} =$ CAT 5E | $P_{SHORT} =$ CAT 5 |
| CAT 6 Cable, 0-100 m | 8 | 5 | | |
| CAT 5E Cable, 0-100 m | 5 | | 5 | |
| CAT 5 Cable, 0-100 m | 11 | | | 2 |
| CAT 6 Cable, 101-160 m | 14 | 6 | | |
| CAT 5E Cable, 101-160 m | 7 | | 6 | |
| CAT 5 Cable, 101-160 m | 11 | | | 3 |

Datasheet

3.8.11.2 Matched Cable Diagnostics

Matched cable diagnostics enable cable length estimation on 100 Mbps-linked cables of up to 120 meters. If there is an active 100 Mb link, the approximate distance to the link partner can be estimated using the [Cable Length Register](#). If the cable is properly terminated, but there is no active 100 Mb link (the link partner is disabled, nonfunctional, the link is at 10 Mb, etc.), the cable length cannot be estimated and the [Cable Length Register](#) should be ignored. The estimated distance to the link partner can be determined via the [Cable Length \(CBLN\)](#) lookup table provided in [Table 3.12](#). The typical cable length measurement margin of error for a matched cable case is +/- 20 m. The matched cable length margin of error is consistent for all cable types from 0 to 120 m.

Table 3.12 Match Case Estimated Cable Length (CBLN) Lookup Table

| CBLN FIELD VALUE | ESTIMATED CABLE LENGTH |
|------------------|------------------------|
| 0 - 3 | 0 |
| 4 | 6 |
| 5 | 17 |
| 6 | 27 |
| 7 | 38 |
| 8 | 49 |
| 9 | 59 |
| 10 | 70 |
| 11 | 81 |
| 12 | 91 |
| 13 | 102 |
| 14 | 113 |
| 15 | 123 |

Note: For a properly terminated cable (Match case), there is no reflected signal. In this case, the [TDR Channel Length](#) field is invalid and should be ignored.

3.8.12 Loopback Operation

The device may be configured for near-end loopback and far loopback. These loopback modes are detailed in the following subsections.

3.8.12.1 Near-end Loopback

Near-end loopback mode sends the digital transmit data back out the receive data signals for testing purposes, as indicated by the blue arrows in Figure 3.14. The near-end loopback mode is enabled by setting the **Loopback** bit of the **Basic Control Register** to "1". A large percentage of the digital circuitry is operational in near-end loopback mode because data is routed through the PCS and PMA layers into the PMD sublayer before it is looped back. The COL signal will be inactive in this mode, unless **Collision Test** is enabled in the **Basic Control Register**. The transmitters are powered down regardless of the state of TXEN. Refer to Section 5.6.3.1, "100 Mbps Internal Loopback MII Timing," on page 133 for additional loopback timing information.

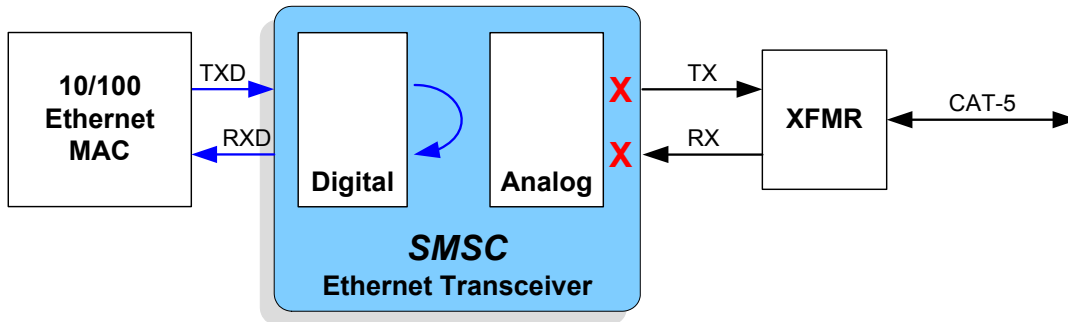

Figure 3.14 Near-end Loopback Block Diagram

3.8.12.2 Far Loopback

Far loopback is a special test mode for MDI (analog) loopback as indicated by the blue arrows in Figure 3.15. The far loopback mode is enabled by setting the **FARLOOPBACK** bit of the **Mode Control/Status Register** to "1". In this mode, data that is received from the link partner on the MDI is looped back out to the link partner. The digital interface signals on the local MAC interface are isolated.

Note: This special test mode is only available when operating in RMII mode.

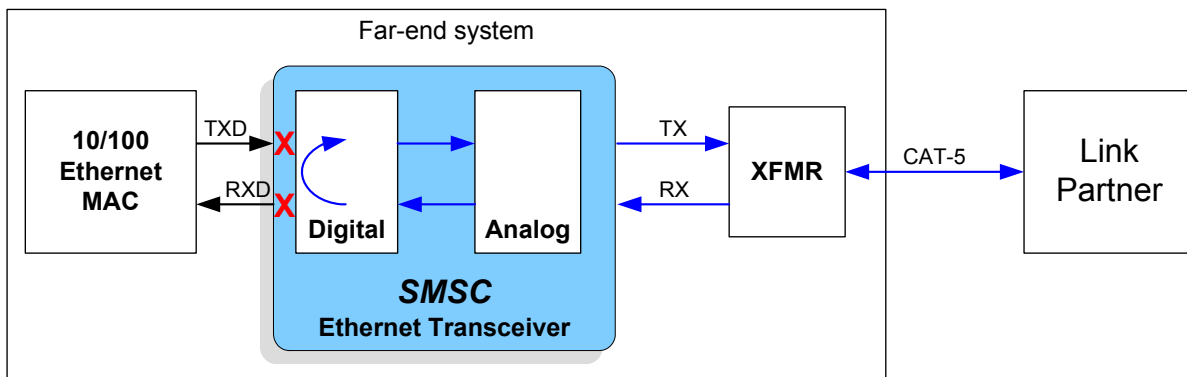

Figure 3.15 Far Loopback Block Diagram

Datasheet

3.8.12.3 Connector Loopback

The device maintains reliable transmission over very short cables and can be tested in a connector loopback as shown in Figure 3.16. An RJ45 loopback cable can be used to route the transmit signals from the output of the transformer back to the receiver inputs. The loopback works at both 10 and 100 Mbps.

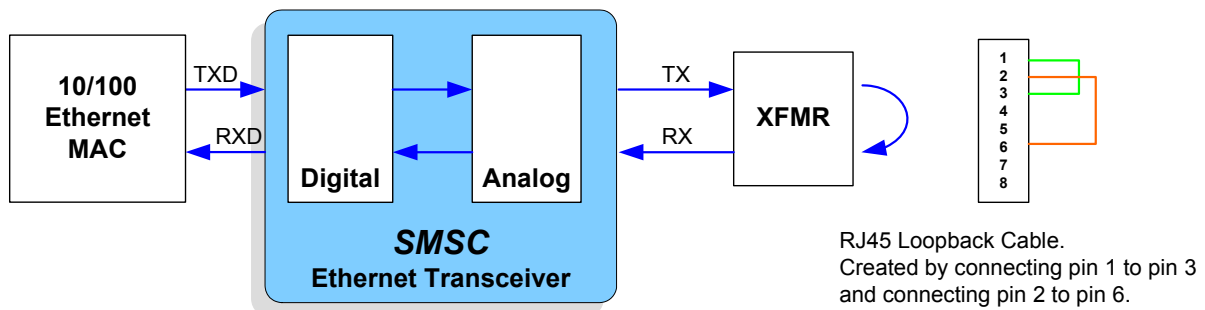

Figure 3.16 Connector Loopback Block Diagram

3.9 Application Diagrams

This section provides typical application diagrams for the following:

- Simplified System Level Application Diagram
- Power Supply Diagram (1.2 V Supplied by Internal Regulator)
- Power Supply Diagram (1.2 V Supplied by External Source)
- Twisted-Pair Interface Diagram (Single Power Supply)
- Twisted-Pair Interface Diagram (Dual Power Supplies)

3.9.1 Simplified System Level Application Diagram

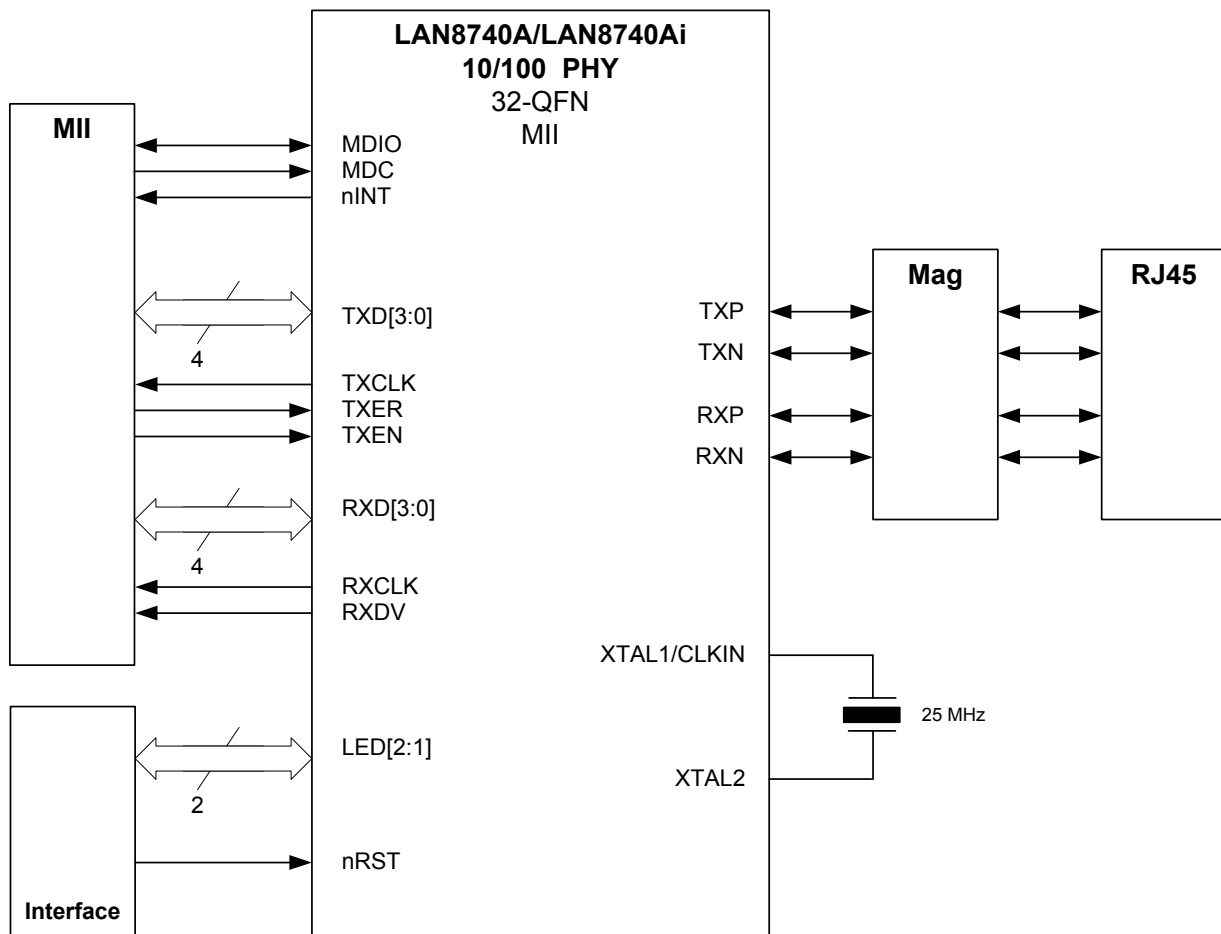

Figure 3.17 Simplified System Level Application Diagram

Datasheet

3.9.2 Power Supply Diagram (1.2 V Supplied by Internal Regulator)

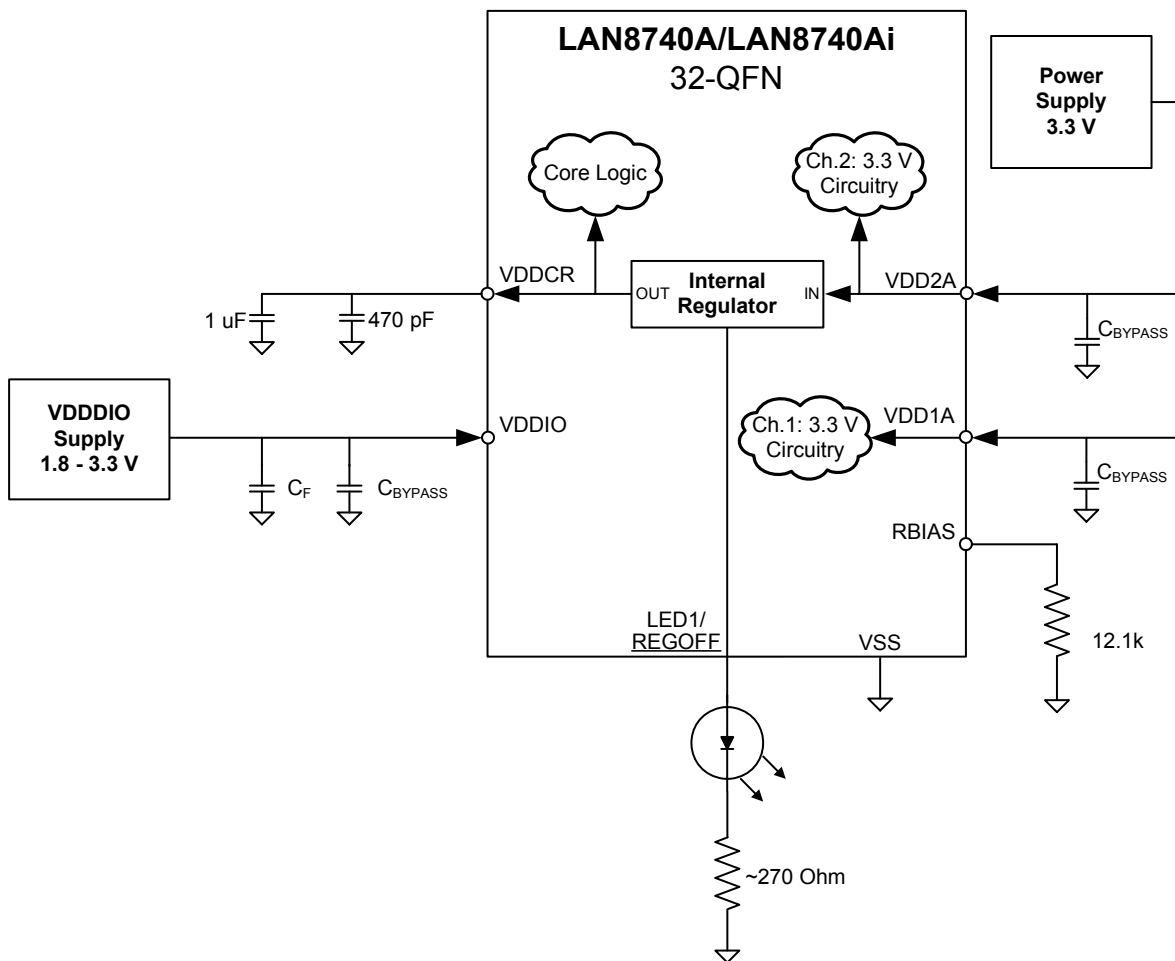

Figure 3.18 Power Supply Diagram (1.2 V Supplied by Internal Regulator)

3.9.3 Power Supply Diagram (1.2 V Supplied by External Source)

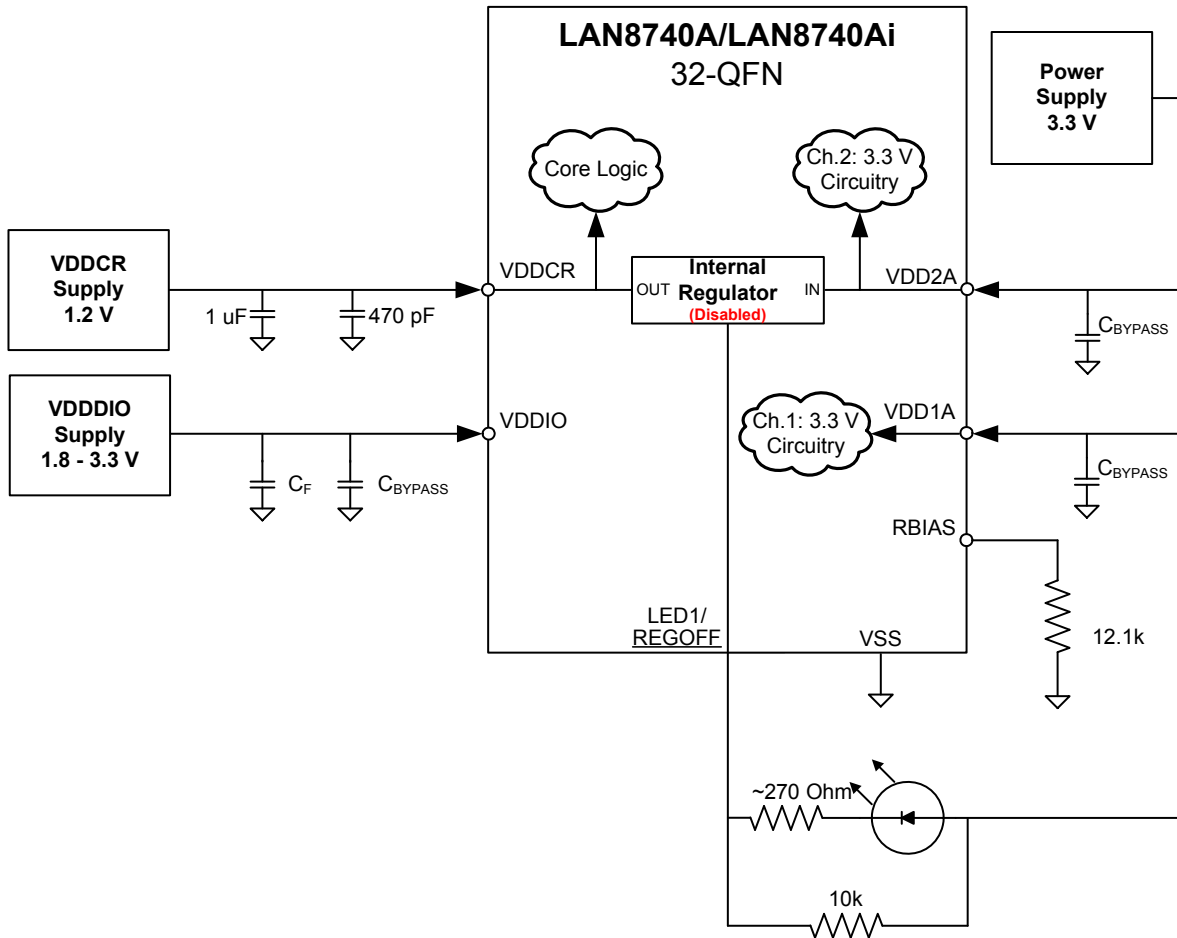

Figure 3.19 Power Supply Diagram (1.2 V Supplied by External Source)

Datasheet

3.9.4 Twisted-Pair Interface Diagram (Single Power Supply)

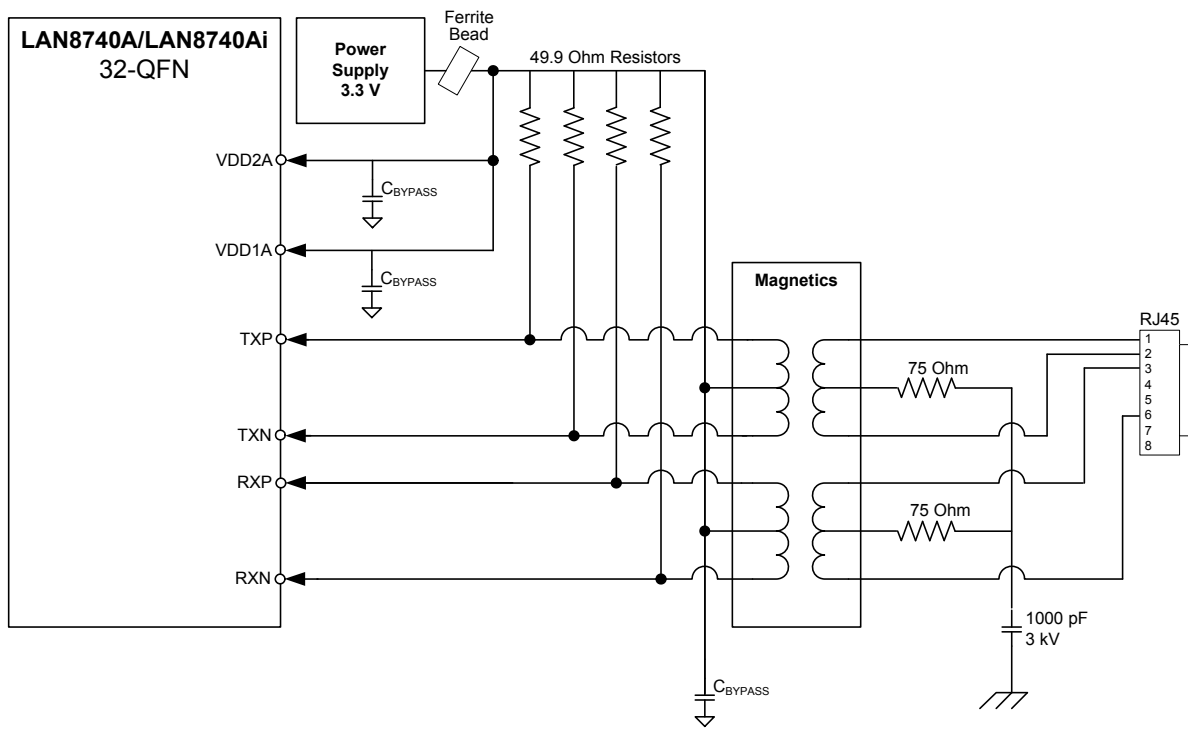

Figure 3.20 Twisted-Pair Interface Diagram (Single Power Supply)

3.9.5 Twisted-Pair Interface Diagram (Dual Power Supplies)

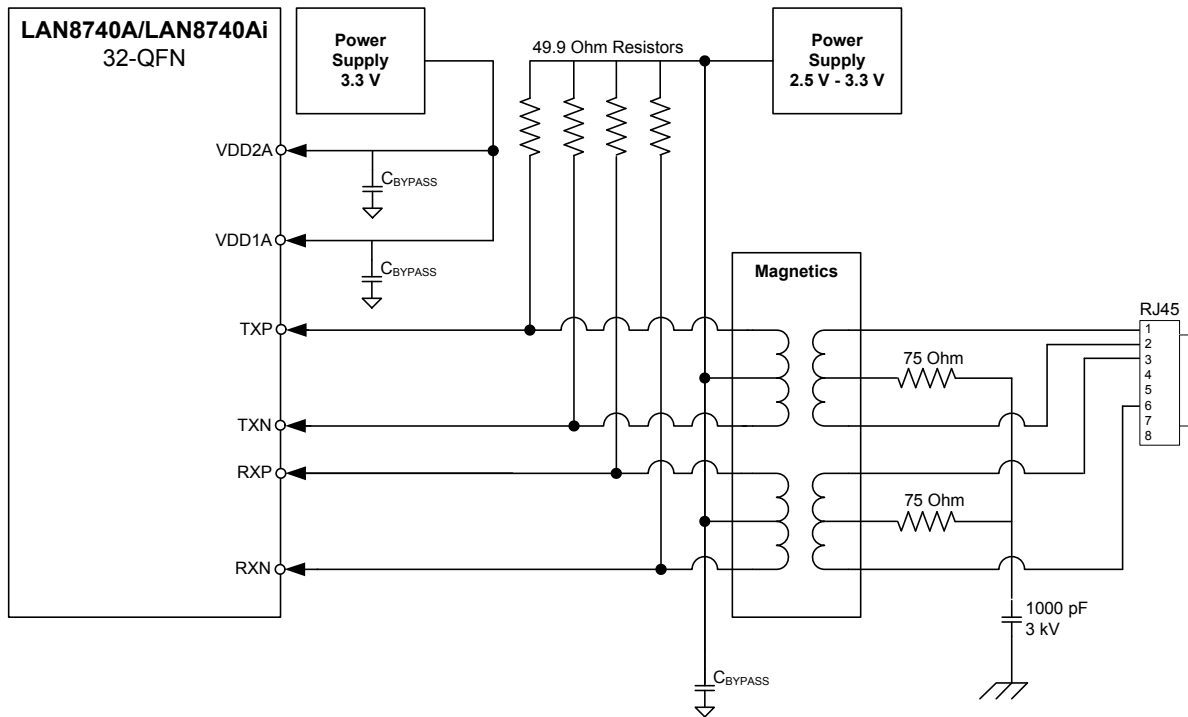

Figure 3.21 Twisted-Pair Interface Diagram (Dual Power Supplies)

Chapter 4 Register Descriptions

This chapter describes the various [Control and Status Registers \(CSRs\)](#) and [MDIO Manageable Device \(MMD\) Registers](#). The CSRs follow the IEEE 802.3 (clause 22.2.4) management register set. The MMD registers adhere to the *IEEE 802.3-2008 45.2 MDIO Interface Registers* specification. All functionality and bit definitions comply with these standards. The IEEE 802.3 specified register index (in decimal) is included with each CSR definition, allowing for addressing of these registers via the Serial Management Interface (SMI) protocol. MMD registers are accessed indirectly via the [MMD Access Control Register](#) and [MMD Access Address/Data Register](#) CSRs.

4.1 Register Nomenclature

[Table 4.1](#) describes the register bit attribute notation used throughout this document.

Table 4.1 Register Bit Types

| REGISTER BIT TYPE NOTATION | REGISTER BIT DESCRIPTION |
|----------------------------|---|
| R | Read: A register or bit with this attribute can be read. |
| W | Write: A register or bit with this attribute can be written. |
| RO | Read only: Writes have no effect. |
| WO | Write only: If a register or bit is write-only, reads will return unspecified data. |
| WC | Write One to Clear: Writing a one clears the value. Writing a zero has no effect |
| WAC | Write Anything to Clear: Writing anything clears the value. |
| RC | Read to Clear: Contents is cleared after the read. Writes have no effect. |
| LL | Latch Low: Clear on read of register. |
| LH | Latch High: Clear on read of register. |
| SC | Self-Clearing: Contents are self-cleared after the being set. Writes of zero have no effect. Contents can be read. |
| SS | Self-Setting: Contents are self-setting after being cleared. Writes of one have no effect. Contents can be read. |
| RO/LH | Read Only, Latch High: Bits with this attribute will stay high until the bit is read. After it is read, the bit will either remain high if the high condition remains, or will go low if the high condition has been removed. If the bit has not been read, the bit will remain high regardless of a change to the high condition. This mode is used in some Ethernet PHY registers. |
| NASR | Not Affected by Software Reset. The state of NASR bits do not change on assertion of a software reset. |
| RESERVED | Reserved Field: Reserved fields must be written with zeros to ensure future compatibility. The value of reserved bits is not guaranteed on a read. |

Many of these register bit notations can be combined. Some examples of this are shown below:

- **R/W:** Can be written. Will return current setting on a read.
- **R/WAC:** Will return current setting on a read. Writing anything clears the bit.

4.2 Control and Status Registers

Table 4.2 provides a list of supported registers. Register details, including bit definitions, are provided in the preceding subsections.

Table 4.2 SMI Register Map

| REGISTER INDEX (DECIMAL) | REGISTER NAME | GROUP |
|-----------------------------|--|-----------------|
| 0 | Basic Control Register | Basic |
| 1 | Basic Status Register | Basic |
| 2 | PHY Identifier 1 Register | Extended |
| 3 | PHY Identifier 2 Register | Extended |
| 4 | Auto Negotiation Advertisement Register | Extended |
| 5 | Auto Negotiation Link Partner Ability Register | Extended |
| 6 | Auto Negotiation Expansion Register | Extended |
| 7 | Auto Negotiation Next Page TX Register | Extended |
| 8 | Auto Negotiation Next Page RX Register | Extended |
| 13 | MMD Access Control Register | Extended |
| 14 | MMD Access Address/Data Register | Extended |
| 16 | EDPD NLP / Crossover Time / EEE Configuration Register | Vendor-specific |
| 17 | Mode Control/Status Register | Vendor-specific |
| 18 | Special Modes Register | Vendor-specific |
| 24 | TDR Patterns/Delay Control Register | Vendor-specific |
| 25 | TDR Control/Status Register | Vendor-specific |
| 26 | Symbol Error Counter Register | Vendor-specific |
| 27 | Special Control/Status Indications Register | Vendor-specific |
| 28 | Cable Length Register | Vendor-specific |
| 29 | Interrupt Source Flag Register | Vendor-specific |
| 30 | Interrupt Mask Register | Vendor-specific |
| 31 | PHY Special Control/Status Register | Vendor-specific |

Datasheet

4.2.1 Basic Control Register

Index (In Decimal): 0

Size: 16 bits

| BITS | DESCRIPTION | TYPE | DEFAULT |
|------|---|-----------|--------------------------|
| 15 | Soft Reset 1 = Software reset. Bit is self-clearing. When setting this bit do not set other bits in this register. Note: The configuration (as described in Section 3.7.2, "MODE[2:0]: Mode Configuration," on page 40) is set from the register bit values, and not from the mode pins. | R/W SC | 0b |
| 14 | Loopback 0 = Normal operation 1 = Loopback mode | R/W | 0b |
| 13 | Speed Select 0 = 10 Mbps 1 = 100 Mbps Note: Ignored if auto-negotiation is enabled (0.12 = 1). | R/W | Note 4.1 |
| 12 | Auto-Negotiation Enable 0 = Disable auto-negotiate process 1 = Enable auto-negotiate process (overrides 0.13 and 0.8) | R/W | Note 4.1 |
| 11 | Power Down 0 = Normal operation 1 = General power down mode | R/W | 0b |
| 10 | Isolate 0 = Normal operation 1 = Electrical isolation of PHY from the MII/RMII | R/W | 0b |
| 9 | Restart Auto-Negotiate 0 = Normal operation 1 = Restart auto-negotiate process Note: Bit is self-clearing. | R/W SC | 0b |
| 8 | Duplex Mode 0 = Half duplex 1 = Full duplex Note: Ignored if Auto-Negotiation is enabled (0.12 = 1). | R/W | Note 4.1 |
| 7 | Collision Test 0 = Disable COL test 1 = Enable COL test | R/W | 0b |
| 6:0 | RESERVED | RO | - |

Note 4.1 The default value of this bit is determined by the MODE[2:0] configuration straps. Refer to [Section 3.7.2, "MODE\[2:0\]: Mode Configuration," on page 40](#) for additional information.

4.2.2 Basic Status Register

Index (In Decimal): 1

Size: 16 bits

| BITS | DESCRIPTION | TYPE | DEFAULT |
|------|---|-------|---------|
| 15 | 100BASE-T4 0 = No T4 ability 1 = T4 able | RO | 0b |
| 14 | 100BASE-TX Full Duplex 0 = No TX full duplex ability 1 = TX with full duplex | RO | 1b |
| 13 | 100BASE-TX Half Duplex 0 = No TX half duplex ability 1 = TX with half duplex | RO | 1b |
| 12 | 10BASE-T Full Duplex 0 = No 10 Mbps with full duplex ability 1 = 10 Mbps with full duplex | RO | 1b |
| 11 | 10BASE-T Half Duplex 0 = No 10 Mbps with half duplex ability 1 = 10 Mbps with half duplex | RO | 1b |
| 10 | 100BASE-T2 Full Duplex 0 = PHY is not able to perform full duplex 100BASE-T2 1 = PHY is able to perform full duplex 100BASE-T2 | RO | 0b |
| 9 | 100BASE-T2 Half Duplex 0 = PHY is not able to perform half duplex 100BASE-T2 1 = PHY is able to perform half duplex 100BASE-T2 | RO | 0b |
| 8 | Extended Status 0 = No extended status information in register 15 1 = Extended status information in register 15 | RO | 0b |
| 7:6 | RESERVED | RO | - |
| 5 | Auto-Negotiate Complete 0 = Auto-negotiate process not completed 1 = Auto-negotiate process completed | RO | 0b |
| 4 | Remote Fault 1 = Remote fault condition detected 0 = No remote fault | RO/LH | 0b |
| 3 | Auto-Negotiate Ability 0 = Unable to perform auto-negotiation function 1 = Able to perform auto-negotiation function | RO | 1b |
| 2 | Link Status 0 = Link is down. 1 = Link is up. | RO/LL | 0b |
| 1 | Jabber Detect 0 = No jabber condition detected. 1 = Jabber condition detected. | RO/LH | 0b |

Datasheet

| BITS | DESCRIPTION | TYPE | DEFAULT |
|------|--|------|---------|
| 0 | Extended Capabilities 0 = Does not support extended capabilities registers 1 = Supports extended capabilities registers | RO | 1b |

4.2.3 PHY Identifier 1 Register

Index (In Decimal): 2

Size: 16 bits

| BITS | DESCRIPTION | TYPE | DEFAULT |
|------|--|------|---------|
| 15:0 | PHY ID Number Assigned to the 3rd through 18th bits of the Organizationally Unique Identifier (OUI), respectively. | R/W | 0007h |

Datasheet

4.2.4 PHY Identifier 2 Register

Index (In Decimal): 3

Size: 16 bits

| BITS | DESCRIPTION | TYPE | DEFAULT |
|-------|--|------|---------|
| 15:10 | PHY ID Number Assigned to the 19th through 24th bits of the OUI. | R/W | C110h |
| 9:4 | Model Number Six-bit manufacturer's model number | R/W | |
| 3:0 | Revision Number Four-bit manufacturer's revision number | R/W | |

Note: The default value of the Revision Number field may vary dependant on the silicon revision number.

4.2.5 Auto Negotiation Advertisement Register

Index (In Decimal): 4

Size: 16 bits

| BITS | DESCRIPTION | TYPE | DEFAULT |
|-------|--|------|--------------------------|
| 15 | Next Page 0 = No next page ability 1 = Next page capable | R/W | 0b |
| 14 | RESERVED | RO | - |
| 13 | Remote Fault 0 = No remote fault 1 = Remote fault detected | R/W | 0b |
| 12 | RESERVED | RO | - |
| 11:10 | Pause Operation 00 = No PAUSE 01 = Symmetric PAUSE 10 = Asymmetric PAUSE toward link partner 11 = Advertise support for both Symmetric PAUSE and Asymmetric PAUSE toward local device Note: When both symmetric PAUSE and asymmetric PAUSE are set, the device will only be configured to, at most, one of the two settings upon auto-negotiation completion. | R/W | 00b |
| 9 | RESERVED | RO | - |
| 8 | 100BASE-TX Full Duplex 0 = No TX full duplex ability 1 = TX with full duplex | R/W | Note 4.2 |
| 7 | 100BASE-TX 0 = No TX ability 1 = TX able | R/W | 1b |
| 6 | 10BASE-T Full Duplex 0 = No 10 Mbps with full duplex ability 1 = 10 Mbps with full duplex | R/W | Note 4.2 |
| 5 | 10BASE-T 0 = No 10 Mbps ability 1 = 10 Mbps able | R/W | Note 4.2 |
| 4:0 | Selector Field 00001 = IEEE 802.3 | R/W | 00001b |

Note 4.2 The default value of this bit is determined by the MODE[2:0] configuration straps. Refer to [Section 3.7.2, "MODE\[2:0\]: Mode Configuration,"](#) on page 40 for additional information.

Datasheet

4.2.6 Auto Negotiation Link Partner Ability Register

Index (In Decimal): 5

Size: 16 bits

| BITS | DESCRIPTION | TYPE | DEFAULT |
|-------|--|------|---------|
| 15 | Next Page 0 = No next page ability 1 = Next page capable | RO | 0b |
| 14 | Acknowledge 0 = Link code word not yet received 1 = Link code word received from partner | RO | 0b |
| 13 | Remote Fault 0 = No remote fault 1 = Remote fault detected | RO | 0b |
| 12 | RESERVED | RO | - |
| 11:10 | Pause Operation 00 = No PAUSE supported by partner station 01 = Symmetric PAUSE supported by partner station 10 = Asymmetric PAUSE supported by partner station 11 = Both Symmetric PAUSE and Asymmetric PAUSE supported by partner station | RO | 00b |
| 9 | 100BASE-T4 0 = No T4 ability 1 = T4 able Note: This device does not support T4 ability. | RO | 0b |
| 8 | 100BASE-TX Full Duplex 0 = No TX full duplex ability 1 = TX with full duplex | RO | 0b |
| 7 | 100BASE-TX 0 = No TX ability 1 = TX able | RO | 0b |
| 6 | 10BASE-T Full Duplex 0 = No 10 Mbps with full duplex ability 1 = 10 Mbps with full duplex | RO | 0b |
| 5 | 10BASE-T 0 = No 10 Mbps ability 1 = 10 Mbps able | RO | 0b |
| 4:0 | Selector Field 00001 = IEEE 802.3 | RO | 00001b |

4.2.7 Auto Negotiation Expansion Register

Index (In Decimal): 6

Size: 16 bits

| BITS | DESCRIPTION | TYPE | DEFAULT |
|------|--|-------|---------|
| 15:7 | RESERVED | RO | - |
| 6 | Receive Next Page Location Able 0 = Received next page storage location is not specified by bit 6.5 1 = Received next page storage location is specified by bit 6.5 | RO | 1b |
| 5 | Received Next Page Storage Location 0 = Link partner next pages are stored in the Auto Negotiation Link Partner Ability Register (PHY register 5) 1 = Link partner next pages are stored in the Auto Negotiation Next Page RX Register (PHY register 8) | RO | 1b |
| 4 | Parallel Detection Fault 0 = No fault detected by parallel detection logic 1 = Fault detected by parallel detection logic | RO/LH | 0b |
| 3 | Link Partner Next Page Able 0 = Link partner does not have next page ability. 1 = Link partner has next page ability. | RO | 0b |
| 2 | Next Page Able 0 = Local device does not have next page ability. 1 = Local device has next page ability. | RO | 1b |
| 1 | Page Received 0 = New page not yet received 1 = New page received | RO/LH | 0b |
| 0 | Link Partner Auto-Negotiation Able 0 = Link partner does not have auto-negotiation ability. 1 = Link partner has auto-negotiation ability. | RO | 0b |

Datasheet

4.2.8 Auto Negotiation Next Page TX Register

Index (In Decimal): 7

Size: 16 bits

| BITS | DESCRIPTION | TYPE | DEFAULT |
|------|--|------|----------------------|
| 15 | Next Page 0 = No next page ability 1 = Next page capable | R/W | 0b |
| 14 | RESERVED | RO | - |
| 13 | Message Page 0 = Unformatted page 1 = Message page | R/W | 1b |
| 12 | Acknowledge 2 0 = Device cannot comply with message. 1 = Device will comply with message. | R/W | 0b |
| 11 | Toggle 0 = Previous value was HIGH. 1 = Previous value was LOW. | RO | 0b |
| 10:0 | Message Code Message/Unformatted Code Field | R/W | 000 0000 0001b |

4.2.9 Auto Negotiation Next Page RX Register

Index (In Decimal): 8

Size: 16 bits

| BITS | DESCRIPTION | TYPE | DEFAULT |
|------|--|------|----------------------|
| 15 | Next Page 0 = No next page ability 1 = Next page capable | RO | 0b |
| 14 | Acknowledge 0 = Link code word not yet received from partner 1 = Link code word received from partner | RO | 0b |
| 13 | Message Page 0 = Unformatted page 1 = Message page | RO | 0b |
| 12 | Acknowledge 2 0 = Device cannot comply with message. 1 = Device will comply with message. | RO | 0b |
| 11 | Toggle 0 = Previous value was HIGH. 1 = Previous value was LOW. | RO | 0b |
| 10:0 | Message Code Message/Unformatted Code Field | RO | 000 0000 0000b |

Datasheet

4.2.10 MMD Access Control Register

Index (In Decimal): 13

Size: 16 bits

This register in conjunction with the [MMD Access Address/Data Register](#) provides indirect access to the MDIO Manageable Device (MMD) registers. Refer to [Section 4.3, "MDIO Manageable Device \(MMD\) Registers,"](#) on page 93 for additional details.

| BITS | DESCRIPTION | TYPE | DEFAULT |
|-------------|---|-------------|----------------|
| 15:14 | MMD Function This field is used to select the desired MMD function: 00 = Address 01 = Data, no post increment 10 = RESERVED 11 = RESERVED | R/W | 00b |
| 13:5 | RESERVED | RO | - |
| 4:0 | MMD Device Address (DEVAD) This field is used to select the desired MMD device address. (3 = PCS, 7 = auto-negotiation) | R/W | 0h |

4.2.11 MMD Access Address/Data Register

Index (In Decimal): 14

Size: 16 bits

This register in conjunction with the [MMD Access Control Register](#) provides indirect access to the MDIO Manageable Device (MMD) registers. Refer to [Section 4.3, "MDIO Manageable Device \(MMD\) Registers," on page 93](#) for additional details.

| BITS | DESCRIPTION | TYPE | DEFAULT |
|------|--|------|---------|
| 15:0 | MMD Register Address/Data If the MMD Function field of the MMD Access Control Register is "00", this field is used to indicate the MMD register address to read/write of the device specified in the MMD Device Address (DEVAD) field. Otherwise, this register is used to read/write data from/to the previously specified MMD address. | R/W | 0000h |

Datasheet

4.2.12 EDPD NLP / Crossover Time / EEE Configuration Register

Index (In Decimal): 16

Size: 16 bits

| BITS | DESCRIPTION | TYPE | DEFAULT |
|-------|--|-------------|---------|
| 15 | EDPD TX NLP Enable When in Energy Detect Power-Down (EDPD) mode (EDPWRDOWN = 1), this bit enables the transmission of single TX NLPs at the interval defined by the EDPD TX NLP Interval Timer Select field. 0 = TX NLP disabled 1 = TX NLP enabled when in EDPD mode | R/W NASR | 0b |
| 14:13 | EDPD TX NLP Interval Timer Select When in Energy Detect Power-Down (EDPD) mode (EDPWRDOWN = 1) and EDPD TX NLP Enable is 1, this field defines the interval used to send single TX NLPs. 00 = 1 second (default) 01 = 768 ms 10 = 512 ms 11 = 256 ms | R/W NASR | 00b |
| 12 | EDPD RX Single NLP Wake Enable When in Energy Detect Power-Down (EDPD) mode (EDPWRDOWN = 1), this bit enables waking the PHY on reception of a single RX NLP. 0 = RX NLP wake disabled 1 = TX NLP wake enabled when in EDPD mode | R/W NASR | 0b |
| 11:10 | EDPD RX NLP Max Interval Detect Select When in Energy Detect Power-Down (EDPD) mode (EDPWRDOWN = 1) and EDPD RX Single NLP Wake Enable is 0, this field defines the maximum interval for detecting two RX NLPs to wake from EDPD mode 00 = 64 ms (default) 01 = 256 ms 10 = 512 ms 11 = 1 second | R/W NASR | 00b |
| 9:3 | RESERVED | RO | - |
| 2 | PHY Energy Efficient Ethernet Enable (PHYEEEEEN) When set, enables Energy Efficient Ethernet (EEE) operation in the PHY. When cleared, EEE operation is disabled. Refer to Section 3.8.5, "Energy Efficient Ethernet," on page 54 for additional information. | R/W NASR | 0b |
| 1 | EDPD Extend Crossover When in Energy Detect Power-Down (EDPD) mode (EDPWRDOWN = 1), setting this bit to 1 extends the crossover time by 2976 ms. 0 = Crossover time extension disabled 1 = Crossover time extension enabled (2976 ms) | R/W NASR | 0b |
| 0 | Extend Manual 10/100 Auto-MDIX Crossover Time When Auto-MIDX is enabled and the PHY is in manual 10BASE-T or 100BASE-TX mode, setting this bit to 1 extends the crossover time by 1984 ms to allow linking to an auto-negotiation link partner PHY. 0 = Crossover time extension disabled 1 = Crossover time extension enabled (1984 ms) | R/W NASR | 1b |

4.2.13 Mode Control/Status Register

Index (In Decimal): 17

Size: 16 bits

| BITS | DESCRIPTION | TYPE | DEFAULT |
|-------|---|------|---------|
| 15:14 | RESERVED | RO | - |
| 13 | <p>EDPWRDOWN Enable the Energy Detect Power-Down (EDPD) mode: 0 = Energy Detect Power-Down is disabled. 1 = Energy Detect Power-Down is enabled.</p> <p>Note: When in EDPD mode, the device's NLP characteristics can be modified via the EDPD NLP / Crossover Time / EEE Configuration Register.</p> | R/W | 0b |
| 12:10 | RESERVED | RO | - |
| 9 | <p>FARLOOPBACK Enables far loopback mode (i.e., all the received packets are sent back simultaneously (in 100BASE-TX only)). This bit is only active in RMII mode. This mode works even if the Isolate bit (0.10) is set. 0 = Far loopback mode is disabled. 1 = Far loopback mode is enabled. Refer to Section 3.8.12.2, "Far Loopback," on page 61 for additional information.</p> | R/W | 0b |
| 8:7 | RESERVED | RO | - |
| 6 | <p>ALTINT Alternate Interrupt Mode: 0 = Primary interrupt system enabled (Default) 1 = Alternate interrupt system enabled Refer to Section 3.6, "Interrupt Management," on page 36 for additional information.</p> | R/W | 0b |
| 5:2 | RESERVED | RO | - |
| 1 | <p>ENERGYON Indicates whether energy is detected. This bit transitions to "0" if no valid energy is detected within 256 ms. It is reset to "1" by a hardware reset and is unaffected by a software reset. Refer to Section 3.8.3.2, "Energy Detect Power-Down (EDPD)," on page 48 for additional information.</p> | RO | 1b |
| 0 | RESERVED | R/W | 0b |

Datasheet

4.2.14 Special Modes Register

Index (In Decimal): 18

Size: 16 bits

| BITS | DESCRIPTION | TYPE | DEFAULT |
|------|--|-------------|--------------------------|
| 15 | RESERVED | RO | - |
| 14 | MIIMODE Reflects the mode of the digital interface: 0 = MII mode 1 = RMII mode | RO | Note 4.3 |
| 13:8 | RESERVED | RO | - |
| 7:5 | MODE Transceiver mode of operation. Refer to Section 3.7.2, "MODE[2:0]: Mode Configuration," on page 40 for additional details. | R/W NASR | Note 4.4 |
| 4:0 | PHYAD PHY Address. The PHY Address is used for the SMI address and for initialization of the Cipher (Scrambler) key. Refer to Section 3.7.1, "PHYAD[2:0]: PHY Address Configuration," on page 39 for additional details. | R/W NASR | Note 4.5 |

Note 4.3 The default value of this field is determined by the RMIISEL configuration strap. Refer to [Section 3.7.3, "RMIISEL: MII/RMII Mode Configuration,"](#) on page 41 for additional information.

Note 4.4 The default value of this field is determined by the MODE[2:0] configuration straps. Refer to [Section 3.7.2, "MODE\[2:0\]: Mode Configuration,"](#) on page 40 for additional information.

Note 4.5 The default value of this field is determined by the PHYAD[0] configuration strap. Refer to [Section 3.7.1, "PHYAD\[2:0\]: PHY Address Configuration,"](#) on page 39 for additional information.

4.2.15 TDR Patterns/Delay Control Register

Index (In Decimal): 24

Size: 16 bits

| BITS | DESCRIPTION | TYPE | DEFAULT |
|-------|---|-------------|---------|
| 15 | TDR Delay In 0 = Line break time is 2 ms. 1 = The device uses TDR Line Break Counter to increase the line break time before starting TDR. | R/W NASR | 0b |
| 14:12 | TDR Line Break Counter When TDR Delay In is 1, this field specifies the increase in line break time in increments of 256 ms, up to 2 seconds. | R/W NASR | 000b |
| 11:6 | TDR Pattern High This field specifies the data pattern sent in TDR mode for the high cycle. | R/W NASR | 101110b |
| 5:0 | TDR Pattern Low This field specifies the data pattern sent in TDR mode for the low cycle. | R/W NASR | 011101b |

Datasheet

4.2.16 TDR Control/Status Register

Index (In Decimal): 25

Size: 16 bits

| BITS | DESCRIPTION | TYPE | DEFAULT |
|-------|--|-------------------|---------|
| 15 | <p>TDR Enable 0 = TDR mode disabled 1 = TDR mode enabled</p> <p>Note: This bit self clears when TDR completes (TDR Channel Status goes high)</p> | R/W NASR SC | 0b |
| 14 | <p>TDR Analog to Digital Filter Enable 0 = TDR analog to digital filter disabled 1 = TDR analog to digital filter enabled (reduces noise spikes during TDR pulses)</p> | R/W NASR | 0b |
| 13:11 | RESERVED | RO | - |
| 10:9 | <p>TDR Channel Cable Type Indicates the cable type determined by the TDR test. 00 = Default 01 = Shorted cable condition 10 = Open cable condition 11 = Match cable condition</p> | R/W NASR | 00b |
| 8 | <p>TDR Channel Status When high, this bit indicates that the TDR operation has completed. This bit will stay high until reset or the TDR operation is restarted (TDR Enable = 1)</p> | R/W NASR | 0b |
| 7:0 | <p>TDR Channel Length This eight bit value indicates the TDR channel length during a short or open cable condition. Refer to Section 3.8.11.1, "Time Domain Reflectometry (TDR) Cable Diagnostics," on page 56 for additional information on the usage of this field.</p> <p>Note: This field is not valid during a match cable condition. The Cable Length Register must be used to determine cable length during a non-open/short (match) condition. Refer to Section 3.8.11, "Cable Diagnostics," on page 56 for additional information.</p> | R/W NASR | 00h |

4.2.17 Symbol Error Counter Register

Index (In Decimal): 26

Size: 16 bits

| BITS | DESCRIPTION | TYPE | DEFAULT |
|------|--|------|---------|
| 15:0 | <p>Symbol Error Counter (SYM_ERR_CNT) This 100BASE-TX receiver-based error counter increments when an invalid code symbol is received, including IDLE symbols. The counter is incremented only once per packet, even when the received packet contains more than one symbol error. This field counts up to 65,536 and rolls over to 0 if incremented beyond it's maximum value.</p> <p>Note: This register is cleared on reset, but is not cleared by reading the register. It does not increment in 10BASE-T mode.</p> | RO | 0000h |

Datasheet

4.2.18 Special Control/Status Indications Register

Index (In Decimal): 27

Size: 16 bits

| BITS | DESCRIPTION | TYPE | DEFAULT |
|-------------|---|-------------|----------------|
| 15 | AMDIXCTRL HP Auto-MDIX control: 0 = Enable Auto-MDIX 1 = Disable Auto-MDIX (use 27.13 to control channel) | R/W NASR | 0b |
| 14 | RESERVED | RO | - |
| 13 | CH_SELECT Manual channel select: 0 = MDI (TX transmits, RX receives) 1 = MDIX (TX receives, RX transmits) | R/W NASR | 0b |
| 12 | RESERVED | RO | - |
| 11 | SQEOFF Disable the SQE test (Heartbeat): 0 = SQE test is enabled 1 = SQE test is disabled | R/W NASR | 0b |
| 10:5 | RESERVED | RO | - |
| 4 | XPOL Polarity state of the 10BASE-T: 0 = Normal polarity 1 = Reversed polarity | RO | 0b |
| 3:0 | RESERVED | RO | - |

4.2.19 Cable Length Register

Index (In Decimal): 28

Size: 16 bits

| BITS | DESCRIPTION | TYPE | DEFAULT |
|-------|--|------|---------|
| 15:12 | <p>Cable Length (CBLN) This four bit value indicates the cable length. Refer to Section 3.8.11.2, "Matched Cable Diagnostics," on page 60 for additional information on the usage of this field.</p> <p>Note: This field indicates cable length for 100BASE-TX linked devices that do not have an open/short on the cable. To determine the open/short status of the cable, the TDR Patterns/Delay Control Register and TDR Control/Status Register must be used. Cable length is not supported for 10BASE-T links. Refer to Section 3.8.11, "Cable Diagnostics," on page 56 for additional information.</p> | RO | 0000b |
| 11:0 | RESERVED | RO | - |

Datasheet

4.2.20 Interrupt Source Flag Register

Index (In Decimal): 29

Size: 16 bits

| BITS | DESCRIPTION | TYPE | DEFAULT |
|-------------|--|-------------|----------------|
| 15:9 | RESERVED | RO | - |
| 8 | INT8 0 = Not source of interrupt 1 = Wake on LAN (WoL) event detected | RO/LH | 0b |
| 7 | INT7 0 = Not source of interrupt 1 = ENERGYON generated | RO/LH | 0b |
| 6 | INT6 0 = Not source of interrupt 1 = Auto-Negotiation complete | RO/LH | 0b |
| 5 | INT5 0 = Not source of interrupt 1 = Remote Fault Detected | RO/LH | 0b |
| 4 | INT4 0 = Not source of interrupt 1 = Link Down (link status negated) | RO/LH | 0b |
| 3 | INT3 0 = Not source of interrupt 1 = Auto-Negotiation LP Acknowledge | RO/LH | 0b |
| 2 | INT2 0 = Not source of interrupt 1 = Parallel Detection Fault | RO/LH | 0b |
| 1 | INT1 0 = Not source of interrupt 1 = Auto-Negotiation Page Received | RO/LH | 0b |
| 0 | RESERVED | RO | 0b |

4.2.21 Interrupt Mask Register

Index (In Decimal): 30

Size: 16 bits

| BITS | DESCRIPTION | TYPE | DEFAULT |
|------|---|------|----------|
| 15:9 | RESERVED | RO | - |
| 8:1 | Mask Bits These bits mask the corresponding interrupts in the Interrupt Source Flag Register . 0 = Interrupt source is masked. 1 = Interrupt source is enabled. | R/W | 0000000b |
| 0 | RESERVED | RO | - |

Datasheet

4.2.22 PHY Special Control/Status Register

Index (In Decimal): 31

Size: 16 bits

| BITS | DESCRIPTION | TYPE | DEFAULT |
|-------------|--|-------------|----------------|
| 15:13 | RESERVED | RO | - |
| 12 | Autodone Auto-negotiation done indication: 0 = Auto-negotiation is not done or disabled (or not active). 1 = Auto-negotiation is done. | RO | 0b |
| 11:7 | RESERVED | RO | - |
| 6 | Enable 4B5B 0 = Bypass encoder/decoder 1 = Enable 4B5B encoding/decoding. MAC interface must be configured in MII mode. | R/W | 1b |
| 5 | RESERVED | RO | - |
| 4:2 | Speed Indication HCDSPEED value: 001 = 10BASE-T half-duplex 101 = 10BASE-T full-duplex 010 = 100BASE-TX half-duplex 110 = 100BASE-TX full-duplex | RO | XXXb |
| 1:0 | RESERVED | RO | - |

4.3 MDIO Manageable Device (MMD) Registers

The device MMD registers adhere to the *IEEE 802.3-2008 45.2 MDIO Interface Registers* specification. The MMD registers are not memory mapped. These registers are accessed indirectly via the [MMD Access Control Register](#) and [MMD Access Address/Data Register](#). The supported MMD device addresses are 3 (PCS), 7 (Auto-Negotiation), and 30 (Vendor Specific). [Table 4.3, "MMD Registers"](#) details the supported registers within each MMD device.

Table 4.3 MMD Registers

| MMD DEVICE ADDRESS (IN DECIMAL) | INDEX (IN DECIMAL) | REGISTER NAME |
|---------------------------------|--|---|
| 3 (PCS) | 0 | PCS Control 1 Register |
| | 1 | PCS Status 1 Register |
| | 5 | PCS MMD Devices Present 1 Register |
| | 6 | PCS MMD Devices Present 2 Register |
| | 20 | EEE Capability Register |
| | 22 | EEE Wake Error Register |
| | 32784 | Wakeup Control and Status Register (WUCSR) |
| | 32785 | Wakeup Filter Configuration Register A (WUF_CFGA) |
| | 32786 | Wakeup Filter Configuration Register B (WUF_CFGB) |
| | 32801 | Wakeup Filter Byte Mask Registers (WUF_MASK) |
| | 32802 | |
| | 32803 | |
| | 32804 | |
| | 32805 | |
| | 32806 | |
| | 32807 | |
| | 32808 | |
| | 32865 | MAC Receive Address A Register (RX_ADDRA) |
| | 32866 | MAC Receive Address B Register (RX_ADDRB) |
| | 32867 | MAC Receive Address C Register (RX_ADDR_C) |
| 32868 | Miscellaneous Configuration Register (MCFGR) | |

Datasheet

Table 4.3 MMD Registers (continued)

| MMD DEVICE ADDRESS (IN DECIMAL) | INDEX (IN DECIMAL) | REGISTER NAME |
|---------------------------------|--------------------|--|
| 7 (Auto-Negotiation) | 5 | Auto-Negotiation MMD Devices Present 1 Register |
| | 6 | Auto-Negotiation MMD Devices Present 2 Register |
| | 60 | EEE Advertisement Register |
| | 61 | EEE Link Partner Advertisement Register |
| 30 (Vendor Specific) | 2 | Vendor Specific MMD 1 Device ID 1 Register |
| | 3 | Vendor Specific MMD 1 Device ID 2 Register |
| | 5 | Vendor Specific 1 MMD Devices Present 1 Register |
| | 6 | Vendor Specific 1 MMD Devices Present 2 Register |
| | 8 | Vendor Specific MMD 1 Status Register |
| | 11 | TDR Match Threshold Register |
| | 12 | TDR Short/Open Threshold Register |
| | 14 | Vendor Specific MMD 1 package ID 1 Register |
| | 15 | Vendor Specific MMD 1 package ID 2 Register |

To read or write an MMD register, the following procedure must be observed:

1. Write the [MMD Access Control Register](#) with 00b (address) for the [MMD Function](#) field and the desired MMD device (3 for PCS, 7 for Auto-Negotiation) for the [MMD Device Address \(DEVAD\)](#) field.
2. Write the [MMD Access Address/Data Register](#) with the 16-bit address of the desired MMD register to read/write within the previously selected MMD device (PCS or Auto-Negotiation).
3. Write the [MMD Access Control Register](#) with 01b (data) for the [MMD Function](#) field and choose the previously selected MMD device (3 for PCS, 7 for Auto-Negotiation) for the [MMD Device Address \(DEVAD\)](#) field.
4. If reading, read the [MMD Access Address/Data Register](#), which contains the selected MMD register contents. If writing, write the [MMD Access Address/Data Register](#) with the register contents intended for the previously selected MMD register.

4.3.1 PCS Control 1 Register

Index (In Decimal): 3.0

Size: 16 bits

| BITS | DESCRIPTION | TYPE | DEFAULT |
|-------|---|------|---------|
| 15:11 | RESERVED | RO | - |
| 10 | Clock Stop Enable 0 = The PHY cannot stop the clock during Low Power Idle (LPI). 1 = The PHY may stop the clock during LPI. Note: The device does not support this mode. | R/W | 0b |
| 9:0 | RESERVED | RO | - |

Datasheet

4.3.2 PCS Status 1 Register

Index (In Decimal): 3.1

Size: 16 bits

| BITS | DESCRIPTION | TYPE | DEFAULT |
|-------------|--|-------------|----------------|
| 15:12 | RESERVED | RO | - |
| 11 | TX LPI Received 0 = TX PCS has not received LPI. 1 = TX PCS has received LPI. | RO/LH | 0b |
| 10 | RX LPI Received 0 = RX PCS has not received LPI. 1 = RX PCS has received LPI. | RO/LH | 0b |
| 9 | TX LPI Indication 0 = TX PCS is not currently receiving LPI. 1 = TX PCS is currently receiving LPI. | RO | 0b |
| 8 | RX LPI Indication 0 = RX PCS is not currently receiving LPI. 1 = RX PCS is currently receiving LPI. | RO | 0b |
| 7 | RESERVED | RO | - |
| 6 | Clock Stop Capable 0 = The MAC cannot stop the clock during Low Power Idle (LPI). 1 = The MAC may stop the clock during LPI. Note: The device does not support this mode. | RO | 0b |
| 5:0 | RESERVED | RO | - |

4.3.3 PCS MMD Devices Present 1 Register

Index (In Decimal): 3.5

Size: 16 bits

| BITS | DESCRIPTION | TYPE | DEFAULT |
|------|--|------|---------|
| 15:8 | RESERVED | RO | - |
| 7 | Auto-Negotiation Present 0 = Auto-negotiation not present in package 1 = Auto-negotiation present in package | RO | 1b |
| 6 | TC Present 0 = TC not present in package 1 = TC present in package | RO | 0b |
| 5 | DTE XS Present 0 = DTE XS not present in package 1 = DTE XS present in package | RO | 0b |
| 4 | PHY XS Present 0 = PHY XS not present in package 1 = PHY XS present in package | RO | 0b |
| 3 | PCS Present 0 = PCS not present in package 1 = PCS present in package | RO | 1b |
| 2 | WIS Present 0 = WIS not present in package 1 = WIS present in package | RO | 0b |
| 1 | PMD/PMA Present 0 = PMD/PMA not present in package 1 = PMD/PMA present in package | RO | 0b |
| 0 | Clause 22 Registers Present 0 = Clause 22 registers not present in package 1 = Clause 22 registers present in package | RO | 0b |

Datasheet

4.3.4 PCS MMD Devices Present 2 Register

Index (In Decimal): 3.6

Size: 16 bits

| BITS | DESCRIPTION | TYPE | DEFAULT |
|------|---|------|---------|
| 15 | Vendor Specific Device 2 Present 0 = Vendor specific device 2 not present in package 1 = Vendor specific device 2 present in package | RO | 0b |
| 14 | Vendor Specific Device 1 Present 0 = Vendor specific device 1 not present in package 1 = Vendor specific device 1 present in package | RO | 1b |
| 13 | Clause 22 Extension Present 0 = Clause 22 extension not present in package 1 = Clause 22 extension present in package | RO | 0b |
| 12:0 | RESERVED | RO | - |

4.3.5 EEE Capability Register

Index (In Decimal): 3.20

Size: 16 bits

| BITS | DESCRIPTION | TYPE | DEFAULT |
|------|---|------|--------------------------|
| 15:7 | RESERVED | RO | - |
| 6 | 10GBASE-KR EEE 0 = EEE is not supported for 10GBASE-KR. 1 = EEE is supported for 10GBASE-KR. Note: The device does not support this mode. | RO | 0b |
| 5 | 10GBASE-KX4 EEE 0 = EEE is not supported for 10GBASE-KX4. 1 = EEE is supported for 10GBASE-KX4. Note: The device does not support this mode. | RO | 0b |
| 4 | 10GBASE-KX EEE 0 = EEE is not supported for 10GBASE-KX. 1 = EEE is supported for 10GBASE-KX. Note: The device does not support this mode. | RO | 0b |
| 3 | 10GBASE-T EEE 0 = EEE is not supported for 10GBASE-T. 1 = EEE is supported for 10GBASE-T. Note: The device does not support this mode. | RO | 0b |
| 2 | 1000BASE-T EEE 0 = EEE is not supported for 1000BASE-T. 1 = EEE is supported for 1000BASE-T. Note: The device does not support this mode. | RO | 0b |
| 1 | 100BASE-TX EEE 0 = EEE is not supported for 100BASE-TX. 1 = EEE is supported for 100BASE-TX. | RO | Note 4.6 |
| 0 | RESERVED | RO | - |

Note 4.6 The default value of this field is determined by the value of the [PHY Energy Efficient Ethernet Enable \(PHYEEEEEN\)](#) of the [EDPD NLP / Crossover Time / EEE Configuration Register on page 82](#). If [PHY Energy Efficient Ethernet Enable \(PHYEEEEEN\)](#) is 0b, this field is 0b and 100BASE-TX EEE capability is not supported. If [PHY Energy Efficient Ethernet Enable \(PHYEEEEEN\)](#) is 1b, then this field is 1b and 100BASE-TX EEE capability is supported.

Datasheet

4.3.6 EEE Wake Error Register

Index (In Decimal): 3.22

Size: 16 bits

| BITS | DESCRIPTION | TYPE | DEFAULT |
|------|--|-------|---------|
| 15:0 | EEE Wake Error Counter This counter is cleared to zeros on read and is held to all ones on overflow. | RO/RC | 0000h |

4.3.7 Wakeup Control and Status Register (WUCSR)

Index (In Decimal): 3.32784

Size: 16 bits

| BITS | DESCRIPTION | TYPE | DEFAULT |
|-------|---|---------------|---------|
| 15 | Interface Disable 0 = MII/RMII interface enabled 1 = MII/RMII interface disabled. Outputs driven to a low level and inputs ignored. | R/W NASR | 0b |
| 14:13 | LED1 Function Select 00 = LED1 functions as Link/Activity. 01 = LED1 functions as nINT. 10 = LED1 functions as nPME. 11 = LED1 functions as Link Speed. Note: Refer to Section 3.8.1, "LEDs," on page 43 for additional information. | R/W NASR | 0b |
| 12:11 | LED2 Function Select 00 = LED2 functions as Link Speed. 01 = LED2 functions as nINT. 10 = LED2 functions as nPME. 11 = LED2 functions as Link/Activity. Note: Refer to Section 3.8.1, "LEDs," on page 43 for additional information. | R/W NASR | 0b |
| 10 | RXD2/RMIISEL Function Select 0 = RXD2/RMIISEL pin functions normally as RXD2/RMIISEL. 1 = RXD2/RMIISEL pin functions as nPME. Note: Refer to Section 3.8.4, "Wake on LAN (WoL)," on page 48 for additional information. | R/W NASR | 0b |
| 9 | nPME Self Clear 0 = nPME pin is not self clearing. 1 = nPME pin is self clearing. Note: When set, the de-assertion delay of the nPME signal is controlled by the nPME Assert Delay bit of the Miscellaneous Configuration Register (MCFGR) . Refer to Section 3.8.4, "Wake on LAN (WoL)," on page 48 for additional information. | R/W NASR | 0b |
| 8 | WoL Configured This bit may be set by software after the WoL registers are configured. This sticky bit (and all other WoL related register bits) is reset only via a power cycle or a pin reset, allowing software to skip programming of the WoL registers in response to a WoL event. Note: Refer to Section 3.8.4, "Wake on LAN (WoL)," on page 48 for additional information. | R/W/ NASR | 0b |
| 7 | Perfect DA Frame Received (PFDA_FR) The MAC sets this bit upon receiving a valid frame with a destination address that matches the physical address. | R/WC/ NASR | 0b |
| 6 | Remote Wakeup Frame Received (WUFR) The MAC sets this bit upon receiving a valid remote Wakeup Frame. | R/WC/ NASR | 0b |

Datasheet

| BITS | DESCRIPTION | TYPE | DEFAULT |
|------|---|---------------|---------|
| 5 | Magic Packet Received (MPR) The MAC sets this bit upon receiving a valid Magic Packet. | R/WC/ NASR | 0b |
| 4 | Broadcast Frame Received (BCAST_FR) The MAC Sets this bit upon receiving a valid broadcast frame. | R/WC/ NASR | 0b |
| 3 | Perfect DA Wakeup Enable (PFDA_EN) When set, remote wakeup mode is enabled and the MAC is capable of waking up on receipt of a frame with a destination address that matches the physical address of the device. The physical address is stored in the MAC Receive Address A Register (RX_ADDRA) , MAC Receive Address B Register (RX_ADDRB) and MAC Receive Address C Register (RX_ADDR_C) . | R/W/ NASR | 0b |
| 2 | Wakeup Frame Enable (WUEN) When set, remote wakeup mode is enabled and the MAC is capable of detecting Wakeup Frames as programmed in the Wakeup Filter. | R/W/ NASR | 0b |
| 1 | Magic Packet Enable (MPEN) When set, Magic Packet wakeup mode is enabled. | R/W/ NASR | 0b |
| 0 | Broadcast Wakeup Enable (BCST_EN) When set, remote wakeup mode is enabled and the MAC is capable of waking up from a broadcast frame. | R/W/ NASR | 0b |

4.3.8 Wakeup Filter Configuration Register A (WUF_CFGA)

Index (In Decimal): 3.32785

Size: 16 bits

| BITS | DESCRIPTION | TYPE | DEFAULT |
|-------|---|---------------|---------|
| 15 | Filter Enable 0 = Filter disabled 1 = Filter enabled | R/W/ NASR | 0b |
| 14 | Filter Triggered 0 = Filter not triggered 1 = Filter triggered | R/WC/ NASR | 0b |
| 13:11 | RESERVED | RO | - |
| 10 | Address Match Enable When set, the destination address must match the programmed address. When cleared, any unicast packet is accepted. Refer to Section 3.8.4.4, "Wakeup Frame Detection," on page 51 for additional information. | R/W/ NASR | 0b |
| 9 | Filter Any Multicast Enable When set, any multicast packet other than a broadcast will cause an address match. Refer to Section 3.8.4.4, "Wakeup Frame Detection," on page 51 for additional information. Note: This bit has priority over bit 10 of this register. | R/W/ NASR | 0b |
| 8 | Filter Broadcast Enable When set, any broadcast frame will cause an address match. Refer to Section 3.8.4.4, "Wakeup Frame Detection," on page 51 for additional information. Note: This bit has priority over bit 10 of this register. | R/W/ NASR | 0b |
| 7:0 | Filter Pattern Offset Specifies the offset of the first byte in the frame on which CRC checking begins for Wakeup Frame recognition. Offset 0 is the first byte of the incoming frame's destination address. | R/W/ NASR | 00h |

Datasheet

4.3.9 Wakeup Filter Configuration Register B (WUF_CFGB)

Index (In Decimal): 3.32786 Size: 16 bits

| BITS | DESCRIPTION | TYPE | DEFAULT |
|------|--|--------------|---------|
| 15:0 | Filter CRC-16 This field specifies the expected 16-bit CRC value for the filter that should be obtained by using the pattern offset and the byte mask programmed for the filter. This value is compared against the CRC calculated on the incoming frame, and a match indicates the reception of a Wakeup Frame. | R/W/ NASR | 0000h |

4.3.10 Wakeup Filter Byte Mask Registers (WUF_MASK)

Index (In Decimal): 3.32801 Size: 16 bits

| BITS | DESCRIPTION | TYPE | DEFAULT |
|-------------|--|--------------|----------------|
| 15:0 | Wakeup Filter Byte Mask [127:112] | R/W/ NASR | 0000h |

Index (In Decimal): 3.32802 Size: 16 bits

| BITS | DESCRIPTION | TYPE | DEFAULT |
|-------------|---|--------------|----------------|
| 15:0 | Wakeup Filter Byte Mask [111:96] | R/W/ NASR | 0000h |

Index (In Decimal): 3.32803 Size: 16 bits

| BITS | DESCRIPTION | TYPE | DEFAULT |
|-------------|--|--------------|----------------|
| 15:0 | Wakeup Filter Byte Mask [95:80] | R/W/ NASR | 0000h |

Index (In Decimal): 3.32804 Size: 16 bits

| BITS | DESCRIPTION | TYPE | DEFAULT |
|-------------|--|--------------|----------------|
| 15:0 | Wakeup Filter Byte Mask [79:64] | R/W/ NASR | 0000h |

Datasheet

Index (In Decimal): 3.32805 Size: 16 bits

| BITS | DESCRIPTION | TYPE | DEFAULT |
|-------------|--|--------------|----------------|
| 15:0 | Wakeup Filter Byte Mask [63:48] | R/W/ NASR | 0000h |

Index (In Decimal): 3.32806 Size: 16 bits

| BITS | DESCRIPTION | TYPE | DEFAULT |
|-------------|--|--------------|----------------|
| 15:0 | Wakeup Filter Byte Mask [47:32] | R/W/ NASR | 0000h |

Index (In Decimal): 3.32807 Size: 16 bits

| BITS | DESCRIPTION | TYPE | DEFAULT |
|-------------|--|--------------|----------------|
| 15:0 | Wakeup Filter Byte Mask [31:16] | R/W/ NASR | 0000h |

Index (In Decimal): 3.32808 Size: 16 bits

| BITS | DESCRIPTION | TYPE | DEFAULT |
|-------------|---------------------------------------|--------------|----------------|
| 15:0 | Wakeup Filter Byte Mask [15:0] | R/W/ NASR | 0000h |

4.3.11 MAC Receive Address A Register (RX_ADDRA)

Index (In Decimal): 3.32865 Size: 16 bits

| BITS | DESCRIPTION | TYPE | DEFAULT |
|------|--------------------------|--------------|---------|
| 15:0 | Physical Address [47:32] | R/W/ NASR | FFFFh |

Note: The MAC address must be loaded into the RX_ADDRA, RX_ADDRB, and RX_ADDRC registers in the proper byte order. For example, a MAC address of 12:34:56:78:9A:BC should be loaded into these registers as follows:

RX_ADDRA = BC9Ah

RX_ADDRB = 7856h

RX_ADDRC = 3412h

Datasheet

4.3.12 MAC Receive Address B Register (RX_ADDRB)

Index (In Decimal): 3.32866 Size: 16 bits

| BITS | DESCRIPTION | TYPE | DEFAULT |
|------|---------------------------------|--------------|---------|
| 15:0 | Physical Address [31:16] | R/W/ NASR | FFFFh |

Note: The MAC address must be loaded into the RX_ADDRA, RX_ADDRB, and RX_ADDRC registers in the proper byte order. For example, a MAC address of 12:34:56:78:9A:BC should be loaded into these registers as follows:

RX_ADDRA = BC9Ah
 RX_ADDRB = 7856h
 RX_ADDRC = 3412h

4.3.13 MAC Receive Address C Register (RX_ADDRC)

Index (In Decimal): 3.32867 Size: 16 bits

| BITS | DESCRIPTION | TYPE | DEFAULT |
|------|-------------------------|--------------|---------|
| 15:0 | Physical Address [15:0] | R/W/ NASR | FFFFh |

Note: The MAC address must be loaded into the RX_ADDRA, RX_ADDRB, and RX_ADDRC registers in the proper byte order. For example, a MAC address of 12:34:56:78:9A:BC should be loaded into these registers as follows:

RX_ADDRA = BC9Ah

RX_ADDRB = 7856h

RX_ADDRC = 3412h

Datasheet

4.3.14 Miscellaneous Configuration Register (MCFGR)

Index (In Decimal): 3.32868 Size: 16 bits

| BITS | DESCRIPTION | TYPE | DEFAULT |
|------|---|--------------|---------|
| 15:0 | <p>nPME Assert Delay This register controls the delay of nPME de-assertion time when the nPME Self Clear bit of the Wakeup Control and Status Register (WUCSR) is set. Each count is equivalent to a 20 µs delay. The delay max is 1.31 seconds. Time = (register value + 1) x 20 µs.</p> | R/W/ NASR | 1000h |

4.3.15 Auto-Negotiation MMD Devices Present 1 Register

Index (In Decimal): 7.5

Size: 16 bits

| BITS | DESCRIPTION | TYPE | DEFAULT |
|------|--|------|---------|
| 15:8 | RESERVED | RO | - |
| 7 | Auto-Negotiation Present 0 = Auto-negotiation not present in package 1 = Auto-negotiation present in package | RO | 1b |
| 6 | TC Present 0 = TC not present in package 1 = TC present in package | RO | 0b |
| 5 | DTE XS Present 0 = DTE XS not present in package 1 = DTE XS present in package | RO | 0b |
| 4 | PHY XS Present 0 = PHY XS not present in package 1 = PHY XS present in package | RO | 0b |
| 3 | PCS Present 0 = PCS not present in package 1 = PCS present in package | RO | 1b |
| 2 | WIS Present 0 = WIS not present in package 1 = WIS present in package | RO | 0b |
| 1 | PMD/PMA Present 0 = PMD/PMA not present in package 1 = PMD/PMA present in package | RO | 0b |
| 0 | Clause 22 Registers Present 0 = Clause 22 registers not present in package 1 = Clause 22 registers present in package | RO | 0b |

Datasheet

4.3.16 Auto-Negotiation MMD Devices Present 2 Register

Index (In Decimal): 7.6

Size: 16 bits

| BITS | DESCRIPTION | TYPE | DEFAULT |
|------|---|------|---------|
| 15 | Vendor Specific Device 2 Present 0 = Vendor specific device 2 not present in package 1 = Vendor specific device 2 present in package | RO | 0b |
| 14 | Vendor Specific Device 1 Present 0 = Vendor specific device 1 not present in package 1 = Vendor specific device 1 present in package | RO | 1b |
| 13 | Clause 22 Extension Present 0 = Clause 22 extension not present in package 1 = Clause 22 extension present in package | RO | 0b |
| 12:0 | RESERVED | RO | - |

4.3.17 EEE Advertisement Register

Index (In Decimal): 7.60

Size: 16 bits

| BITS | DESCRIPTION | TYPE | DEFAULT |
|------|--|--------------------------|--------------------------|
| 15:2 | RESERVED | RO | - |
| 1 | 100BASE-TX EEE 0 = Do not advertise EEE capability for 100BASE-TX. 1 = Advertise EEE capability for 100BASE-TX. | Note 4.7 | Note 4.8 |
| 0 | RESERVED | RO | - |

Note 4.7 This bit is read/write (R/W). However, the user must not set this bit if EEE is disabled.

Note 4.8 The default value of this field is determined by the value of the [PHY Energy Efficient Ethernet Enable \(PHYEEEEEN\)](#) of the [EDPD NLP / Crossover Time / EEE Configuration Register on page 82](#). If [PHY Energy Efficient Ethernet Enable \(PHYEEEEEN\)](#) is 0b, this field is 0b and 100BASE-TX EEE capability is not advertised. If [PHY Energy Efficient Ethernet Enable \(PHYEEEEEN\)](#) is 1b, then this field is 1b and 100BASE-TX EEE capability is advertised.

Datasheet

4.3.18 EEE Link Partner Advertisement Register

Index (In Decimal): 7.61

Size: 16 bits

| BITS | DESCRIPTION | TYPE | DEFAULT |
|-------------|--|-------------|----------------|
| 15:7 | RESERVED | RO | - |
| 6 | 10GBASE-KR EEE 0 = Link partner does not advertise EEE capability for 10GBASE-KR. 1 = Link partner advertises EEE capability for 10GBASE-KR. Note: This device does not support this mode. | RO | 0b |
| 5 | 10GBASE-KX4 EEE 0 = Link partner does not advertise EEE capability for 10GBASE-KX4. 1 = Link partner advertises EEE capability for 10GBASE-KX4. Note: This device does not support this mode. | RO | 0b |
| 4 | 10GBASE-KX EEE 0 = Link partner does not advertise EEE capability for 10GBASE-KX. 1 = Link partner advertises EEE capability for 10GBASE-KX. Note: This device does not support this mode. | RO | 0b |
| 3 | 10GBASE-T EEE 0 = Link partner does not advertise EEE capability for 10GBASE-T. 1 = Link partner advertises EEE capability for 10GBASE-T. Note: This device does not support this mode. | RO | 0b |
| 2 | 1000BASE-T EEE 0 = Link partner does not advertise EEE capability for 1000BASE-T. 1 = Link partner advertises EEE capability for 1000BASE-T. Note: This device does not support this mode. | RO | 0b |
| 1 | 100BASE-TX EEE 0 = Link partner does not advertise EEE capability for 100BASE-TX. 1 = Link partner advertises EEE capability for 100BASE-TX. | RO | 0b |
| 0 | RESERVED | RO | - |

4.3.19 Vendor Specific MMD 1 Device ID 1 Register

Index (In Decimal): 30.2 Size: 16 bits

| BITS | DESCRIPTION | TYPE | DEFAULT |
|-------------|--------------------|-------------|----------------|
| 15:0 | RESERVED | RO | 0000h |

Datasheet

4.3.20 Vendor Specific MMD 1 Device ID 2 Register

Index (In Decimal): 30.3 Size: 16 bits

| BITS | DESCRIPTION | TYPE | DEFAULT |
|-------------|--------------------|-------------|----------------|
| 15:0 | RESERVED | RO | 0000h |

4.3.21 Vendor Specific 1 MMD Devices Present 1 Register

Index (In Decimal): 30.5

Size: 16 bits

| BITS | DESCRIPTION | TYPE | DEFAULT |
|-------------|--|-------------|----------------|
| 15:8 | RESERVED | RO | - |
| 7 | Auto-Negotiation Present 0 = Auto-negotiation not present in package 1 = Auto-negotiation present in package | RO | 1b |
| 6 | TC Present 0 = TC not present in package 1 = TC present in package | RO | 0b |
| 5 | DTE XS Present 0 = DTE XS not present in package 1 = DTE XS present in package | RO | 0b |
| 4 | PHY XS Present 0 = PHY XS not present in package 1 = PHY XS present in package | RO | 0b |
| 3 | PCS Present 0 = PCS not present in package 1 = PCS present in package | RO | 1b |
| 2 | WIS Present 0 = WIS not present in package 1 = WIS present in package | RO | 0b |
| 1 | PMD/PMA Present 0 = PMD/PMA not present in package 1 = PMD/PMA present in package | RO | 0b |
| 0 | Clause 22 Registers Present 0 = Clause 22 registers not present in package 1 = Clause 22 registers present in package | RO | 0b |

Datasheet

4.3.22 Vendor Specific 1 MMD Devices Present 2 Register

Index (In Decimal): 30.6 Size: 16 bits

| BITS | DESCRIPTION | TYPE | DEFAULT |
|------|---|------|---------|
| 15 | Vendor Specific Device 2 Present 0 = Vendor specific device 2 not present in package 1 = Vendor specific device 2 present in package | RO | 0b |
| 14 | Vendor Specific Device 1 Present 0 = Vendor specific device 1 not present in package 1 = Vendor specific device 1 present in package | RO | 1b |
| 13 | Clause 22 Extension Present 0 = Clause 22 extension not present in package 1 = Clause 22 extension present in package | RO | 0b |
| 12:0 | RESERVED | RO | - |

4.3.23 Vendor Specific MMD 1 Status Register

Index (In Decimal): 30.8 Size: 16 bits

| BITS | DESCRIPTION | TYPE | DEFAULT |
|-------|--|------|---------|
| 15:14 | Device Present 00 = No device responding at this address 01 = No device responding at this address 10 = Device responding at this address 11 = No device responding at this address | | 10b |
| 13:0 | RESERVED | RO | - |

Datasheet

4.3.24 TDR Match Threshold Register

Index (In Decimal): 30.11 Size: 16 bits

| BITS | DESCRIPTION | TYPE | DEFAULT |
|-------|--|------|-----------------------------------|
| 15:10 | RESERVED | RO | - |
| 9:5 | TDR Match High Threshold Sets the upper threshold to detect match cable. | R/W | 5'h12 Note 4.9 |
| 4:0 | TDR Match Low Threshold Sets the lower threshold to detect match cable. | R/W | 5'h09 Note 4.9 |

Note 4.9 Software reset places the default values of this register into an indeterminate state. For proper operation of the TDR, the TDR Match High Threshold and TDR Match Low Threshold must be set to 5'h12 and 5'h09, respectively.

4.3.25 TDR Short/Open Threshold Register

Index (In Decimal): 30.12 Size: 16 bits

| BITS | DESCRIPTION | TYPE | DEFAULT |
|-------|---|------|------------------------------------|
| 15:10 | RESERVED | RO | - |
| 9:5 | TDR Short Low Threshold Sets the lower threshold to detect short cable. | R/W | 5'h09 Note 4.10 |
| 4:0 | TDR Open High Threshold Sets the upper threshold to detect open cable. | R/W | 5'h12 Note 4.10 |

Note 4.10 Software reset places the default values of this register into an indeterminate state. For proper operation of the TDR, the TDR Short Low Threshold and TDR Open High Threshold must be set to 5'h09 and 5'h12, respectively.

Datasheet

4.3.26 Vendor Specific MMD 1 package ID 1 Register

Index (In Decimal): 30.14 Size: 16 bits

| BITS | DESCRIPTION | TYPE | DEFAULT |
|------|-----------------|------|---------|
| 15:0 | RESERVED | RO | 0000h |

4.3.27 Vendor Specific MMD 1 package ID 2 Register

Index (In Decimal): 30.15 Size: 16 bits

| BITS | DESCRIPTION | TYPE | DEFAULT |
|-------------|--------------------|-------------|----------------|
| 15:0 | RESERVED | RO | 0000h |

Chapter 5 Operational Characteristics

5.1 Absolute Maximum Ratings*

| | |
|--|--------------------------------|
| Supply Voltage (VDDIO, VDD1A, VDD2A) (Note 5.1) | -0.5 V to +3.6 V |
| Digital Core Supply Voltage (VDDCR) (Note 5.1) | -0.5 V to +1.5 V |
| Ethernet Magnetics Supply Voltage | -0.5 V to +3.6 V |
| Positive voltage on input signal pins, with respect to ground (Note 5.2) | VDDIO + 2.0 V |
| Negative voltage on input signal pins, with respect to ground (Note 5.3) | -0.5 V |
| Positive voltage on XTAL1/CLKIN, with respect to ground | 3.6 V |
| Storage Temperature | -55°C to +150°C |
| Lead Temperature Range | Refer to JEDEC Spec. J-STD-020 |
| HBM ESD Performance | JEDEC Class 3A |

Note 5.1 When powering this device from laboratory or system power supplies, it is important that the absolute maximum ratings not be exceeded or device failure can result. Some power supplies exhibit voltage spikes on their outputs when AC power is switched on or off. In addition, voltage transients on the AC power line may appear on the DC output. If this possibility exists, it is suggested that a clamp circuit be used.

Note 5.2 This rating does not apply to the following pins: XTAL1/CLKIN, XTAL2, RBIAS.

Note 5.3 This rating does not apply to the following pins: RBIAS.

*Stresses exceeding those listed in this section could cause permanent damage to the device. This is a stress rating only. Exposure to absolute maximum rating conditions for extended periods may affect device reliability. Functional operation of the device at any condition exceeding those indicated in [Section 5.2, "Operating Conditions***"](#) or any other applicable section of this specification is not implied. Note, device signals are *NOT* 5.0 V tolerant unless specified otherwise.

5.2 Operating Conditions**

| | |
|--|--------------------------|
| Supply Voltage (VDDIO) | +1.62 V to +3.6 V |
| Analog Port Supply Voltage (VDD1A, VDD2A) | +3.0 V to +3.6 V |
| Digital Core Supply Voltage (VDDCR) | +1.14 V to +1.26 V |
| Ethernet Magnetics Supply Voltage | +2.25 V to +3.6 V |
| Ambient Operating Temperature in Still Air (T_A) | Note 5.4 |

Note 5.4 0°C to +70°C for commercial version, -40°C to +85°C for industrial version.

**Proper operation of the device is guaranteed only within the ranges specified in this section. After the device has completed power-up, VDDIO and the magnetics power supply must maintain their voltage level with $\pm 10\%$. Varying the voltage greater than $\pm 10\%$ after the device has completed power-up can cause errors in device operation.

Note: Do not drive input signals without power supplied to the device.

5.3 Package Thermal Specifications

Table 5.1 Package Thermal Parameters

| PARAMETER | SYMBOL | VALUE | UNITS | COMMENTS |
|----------------------------|---------------|-------|-------|---|
| Thermal Resistance | Θ_{JA} | 47.8 | °C/W | Measured in still air from the die to ambient air |
| Junction-to-Top-of-Package | Ψ_{JT} | 0.7 | °C/W | Measured in still air |

Note: Thermal parameters are measured or estimated for devices in a multi-layer 2S2P PCB per JESD51.

Datasheet

5.4 Power Consumption

This section details the device power measurements taken over various operating conditions. Unless otherwise noted, all measurements were taken with power supplies at nominal values (VDDIO, VDD1A, VDD2A = 3.3 V, VDDCR = 1.2 V). See [Section 3.8.3, "Power-Down Modes,"](#) on page 47 for a description of the power down modes.

5.4.1 Regulator Disabled

Table 5.2 Current Consumption and Power Dissipation (Reg. Disabled)

| POWER PIN GROUP | | 3.3 V DEVICE CURRENT (mA) | 1.2 V DEVICE CURRENT (mA) | 3.3 V DEVICE CURRENT W/ MAGNETICS (mA) | TOTAL DEVICE POWER (mW) |
|--------------------------------|---------|---------------------------|---------------------------|--|-------------------------|
| nRESET | Typical | 9.7 | 11 | 9.7 | 45 |
| 100BASE-TX /W TRAFFIC (NO EEE) | Typical | 32 | 21 | 74 | 130 |
| 10BASE-T /W TRAFFIC | Typical | 11 | 13 | 114 | 51 |
| 100BASE-TX IDLE /W EEE | Typical | 32 | 15 | 32 | 122 |
| ENERGY DETECT POWER DOWN | Typical | 4.0 | 1.7 | 4.0 | 15 |
| GENERAL POWER DOWN | Typical | 0.3 | 1.4 | 0.4 | 2.8 |

5.4.2 Regulator Enabled

Table 5.3 Current Consumption and Power Dissipation (Reg. Enabled)

| POWER PIN GROUP | | DEVICE CURRENT (mA) | DEVICE CURRENT W/ MAGNETICS (mA) | TOTAL DEVICE POWER (mW) |
|--------------------------------|---------|---------------------|----------------------------------|-------------------------|
| nRESET | Typical | 21 | 21 | 70 |
| 100BASE-TX /W TRAFFIC (NO EEE) | Typical | 55 | 97 | 180 |
| 10BASE-T /W TRAFFIC | Typical | 25 | 129 | 82 |
| 100BASE-TX IDLE /W EEE | Typical | 48 | 48 | 158 |
| ENERGY DETECT POWER DOWN | Typical | 7.1 | 7.1 | 24 |
| GENERAL POWER DOWN | Typical | 4.0 | 4.0 | 13 |

5.5 DC Specifications

Table 5.4 details the non-variable I/O buffer characteristics. These buffer types do not support variable voltage operation. Table 5.5 details the variable voltage I/O buffer characteristics. Typical values are provided for 1.8 V, 2.5 V, and 3.3 V VDDIO cases.

Table 5.4 Non-Variable I/O Buffer Characteristics

| PARAMETER | SYMBOL | MIN | TYP | MAX | UNITS | NOTES |
|---|-----------|---------------|------|------|---------|-------------------|
| IS Type Input Buffer | | | | | | |
| Low Input Level | V_{ILI} | -0.3 | | | V | |
| High Input Level | V_{IHI} | | | 3.6 | V | |
| Negative-Going Threshold | V_{ILT} | 1.01 | 1.19 | 1.39 | V | Schmitt trigger |
| Positive-Going Threshold | V_{IHT} | 1.39 | 1.59 | 1.79 | V | Schmitt trigger |
| Schmitt Trigger Hysteresis ($V_{IHT} - V_{ILT}$) | V_{HYS} | 336 | 399 | 459 | mV | |
| Input Leakage ($V_{IN} = VSS$ or $VDDIO$) | I_{IH} | -10 | | 10 | μ A | Note 5.5 |
| Input Capacitance | C_{IN} | | | 2 | pF | |
| O12 Type Buffers | | | | | | |
| Low Output Level | V_{OL} | | | 0.4 | V | $I_{OL} = 12$ mA |
| High Output Level | V_{OH} | $VDD2A - 0.4$ | | | V | $I_{OH} = -12$ mA |
| ICLK Type Buffer (XTAL1 Input) | | | | | | |
| Low Input Level | V_{ILI} | -0.3 | | 0.35 | V | Note 5.6 |
| High Input Level | V_{IHI} | $VDDCR-0.35$ | | 3.6 | V | |

Note 5.5 This specification applies to all inputs and tri-stated bi-directional pins. Internal pull-down and pull-up resistors add ± 50 μ A per-pin (typical).

Note 5.6 XTAL1/CLKIN can optionally be driven from a 25 MHz single-ended clock oscillator.

Datasheet

Table 5.5 Variable I/O Buffer Characteristics

| PARAMETER | SYMBOL | MIN | 1.8 V TYP | 2.5 V TYP | 3.3 V TYP | MAX | UNITS | NOTES |
|--|-----------|------------------|--------------|--------------|--------------|------|---------|------------------|
| VIS Type Input Buffer | | | | | | | | |
| Low Input Level | V_{ILI} | -0.3 | | | | | V | |
| High Input Level | V_{IHI} | | | | | 3.6 | V | |
| Neg-Going Threshold | V_{ILT} | 0.64 | 0.83 | 1.15 | 1.41 | 1.76 | V | Schmitt trigger |
| Pos-Going Threshold | V_{IHT} | 0.81 | 0.99 | 1.29 | 1.65 | 1.90 | V | Schmitt trigger |
| Schmitt Trigger Hysteresis ($V_{IHT} - V_{ILT}$) | V_{HYS} | 102 | 158 | 136 | 138 | 288 | mV | |
| Input Leakage ($V_{IN} = V_{SS}$ or V_{DDIO}) | I_{IH} | -10 | | | | 10 | μ A | Note 5.7 |
| Input Capacitance | C_{IN} | | | | | 2 | pF | |
| VO8 Type Buffers | | | | | | | | |
| Low Output Level | V_{OL} | | | | | 0.4 | V | $I_{OL} = 8$ mA |
| High Output Level | V_{OH} | $V_{DDIO} - 0.4$ | | | | | V | $I_{OH} = -8$ mA |
| VOD8 Type Buffer | | | | | | | | |
| Low Output Level | V_{OL} | | | | | 0.4 | V | $I_{OL} = 8$ mA |

Note 5.7 This specification applies to all inputs and tri-stated bi-directional pins. Internal pull-down and pull-up resistors add ± 50 μ A per-pin (typical).

Table 5.6 100BASE-TX Transceiver Characteristics

| PARAMETER | SYMBOL | MIN | TYP | MAX | UNITS | NOTES |
|---------------------------------------|-----------|------|-----|-------|-------|-----------|
| Peak Differential Output Voltage High | V_{PPH} | 950 | - | 1050 | mVpk | Note 5.8 |
| Peak Differential Output Voltage Low | V_{PPL} | -950 | - | -1050 | mVpk | Note 5.8 |
| Signal Amplitude Symmetry | V_{SS} | 98 | - | 102 | % | Note 5.8 |
| Signal Rise and Fall Time | T_{RF} | 3.0 | - | 5.0 | ns | Note 5.8 |
| Rise and Fall Symmetry | T_{RFS} | - | - | 0.5 | ns | Note 5.8 |
| Duty Cycle Distortion | D_{CD} | 35 | 50 | 65 | % | Note 5.9 |
| Overshoot and Undershoot | V_{OS} | - | - | 5 | % | |
| Jitter | | | | 1.4 | ns | Note 5.10 |

Note 5.8 Measured at line side of transformer, line replaced by 100 Ω ($\pm 1\%$) resistor.

Note 5.9 Offset from 16 ns pulse width at 50% of pulse peak.

Note 5.10 Measured differentially.

Table 5.7 10BASE-T Transceiver Characteristics

| PARAMETER | SYMBOL | MIN | TYP | MAX | UNITS | NOTES |
|--|-----------|-----|-----|-----|-------|-----------|
| Transmitter Peak Differential Output Voltage | V_{OUT} | 2.2 | 2.5 | 2.8 | V | Note 5.11 |
| Receiver Differential Squelch Threshold | V_{DS} | 300 | 420 | 585 | mV | |

Note 5.11 Min/max voltages guaranteed as measured with 100 Ω resistive load.

5.6 AC Specifications

This section details the various AC timing specifications of the device.

5.6.1 Equivalent Test Load

Output timing specifications assume a 25 pF equivalent test load, unless otherwise noted, as illustrated in Figure 5.1 below.

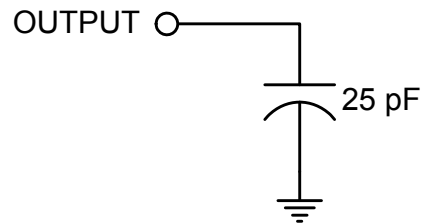

Figure 5.1 Output Equivalent Test Load

Datasheet

5.6.2 Power-On nRST & Configuration Strap Timing

This diagram illustrates the nRST reset and configuration strap timing requirements in relation to power-on. A hardware reset (nRST assertion) is required following power-up. For proper operation, nRST must be asserted for no less than t_{rstia} . The nRST pin can be asserted at any time, but must not be deasserted before t_{purstd} after all external power supplies have reached operational levels. In order for valid configuration strap values to be read at power-up, the t_{css} and t_{csh} timing constraints must be followed. Refer to [Section 3.8.7, "Resets," on page 54](#) for additional information.

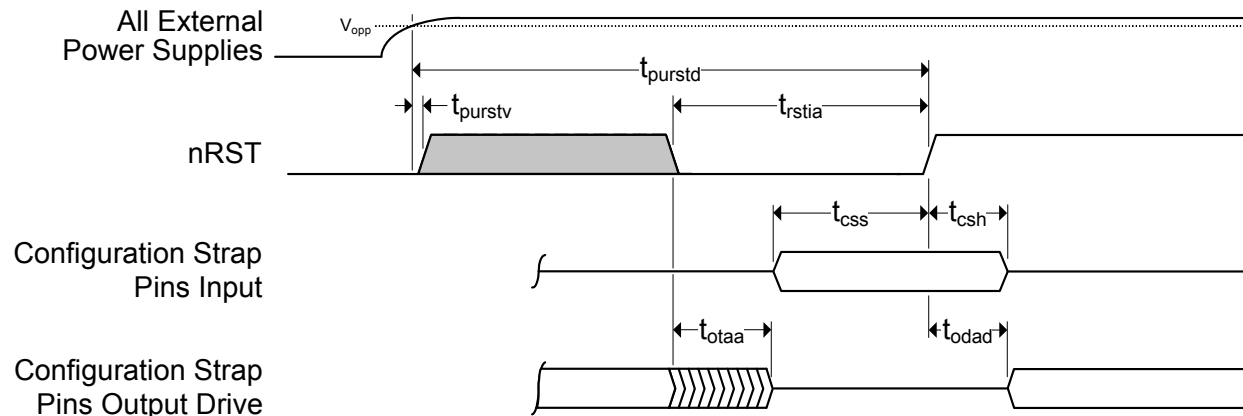

Figure 5.2 Power-On nRST & Configuration Strap Timing

Table 5.8 Power-On nRST & Configuration Strap Timing Values

| SYMBOL | DESCRIPTION | MIN | TYP | MAX | UNITS |
|--------------|--|-----|-----|--------------------|---------|
| t_{purstd} | External power supplies at operational level to nRST deassertion | 25 | | | ms |
| t_{purstv} | External power supplies at operational level to nRST valid | 0 | | | ns |
| t_{rstia} | nRST input assertion time | 100 | | | μ s |
| t_{css} | Configuration strap pins setup to nRST deassertion | 200 | | | ns |
| t_{csh} | Configuration strap pins hold after nRST deassertion | 1 | | | ns |
| t_{otaa} | Output tri-state after nRST assertion | | | 50 | ns |
| t_{odad} | Output drive after nRST deassertion | 2 | | 800 (Note 5.12) | ns |

Note: nRST deassertion must be monotonic.

Note: Device configuration straps are latched as a result of nRST assertion. Refer to [Section 3.7, "Configuration Straps," on page 39](#) for details. Configuration straps must only be pulled high or low and must not be driven as inputs.

Note 5.12 20 clock cycles for 25 MHz, or 40 clock cycles for 50 MHz

5.6.3 MII Interface Timing

This section specifies the MII interface transmit and receive timing. Please refer to [Section 3.4.1, "MII,"](#) on [page 32](#) for additional details.

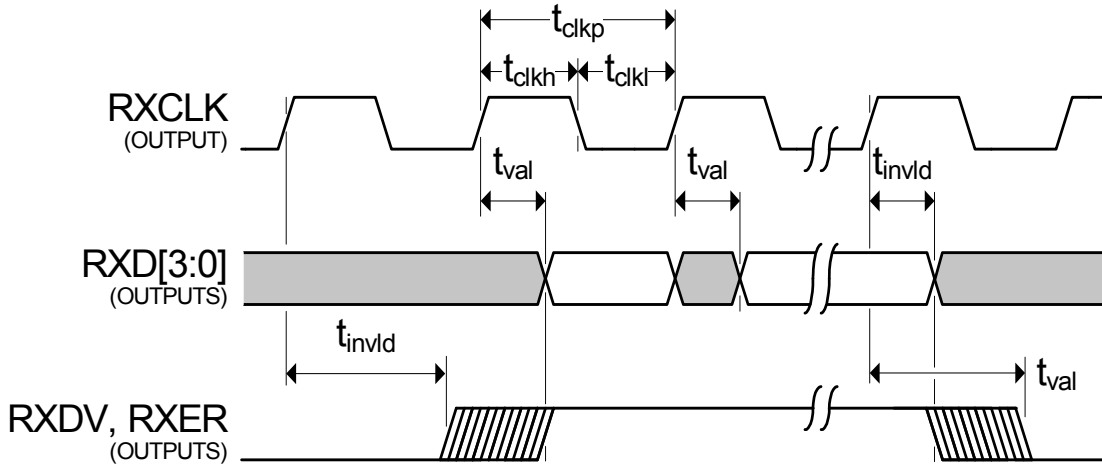

Figure 5.3 MII Receive Timing

Table 5.9 MII Receive Timing Values

| SYMBOL | DESCRIPTION | MIN | TYP | MAX | UNITS | NOTES |
|-------------|---|---------------------------|-----|------------------|-------|---------------------------|
| t_{clkp} | RXCLK period | Note 5.13 | | | ns | |
| t_{clkh} | RXCLK high time | $t_{clkp} * 0.4$ | | $t_{clkp} * 0.6$ | ns | |
| t_{clkl} | RXCLK low time | $t_{clkp} * 0.4$ | | $t_{clkp} * 0.6$ | ns | |
| t_{val} | RXD[3:0], RXDV, RXER output valid from rising edge of RXCLK | | | 28.0 | ns | Note 5.14 |
| t_{invlD} | RXD[3:0], RXDV, RXER output invalid from rising edge of RXCLK | 10.0 | | | ns | Note 5.14 |

Note 5.13 40 ns for 100BASE-TX operation, 400 ns for 10BASE-T operation.

Note 5.14 Timing was designed for system load between 10 pF and 25 pF.

Datasheet

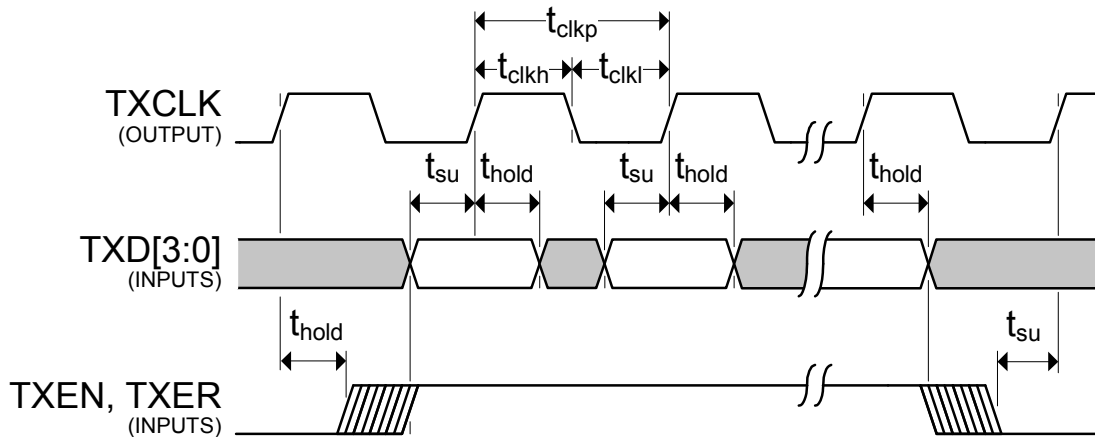

Figure 5.4 MII Transmit Timing

Table 5.10 MII Transmit Timing Values

| SYMBOL | DESCRIPTION | MIN | TYP | MAX | UNITS | NOTES |
|------------|--|------------------|-----|------------------|-------|-----------|
| t_{clkp} | TXCLK period | Note 5.15 | | | ns | |
| t_{clkh} | TXCLK high time | $t_{clkp} * 0.4$ | | $t_{clkp} * 0.6$ | ns | |
| t_{clkl} | TXCLK low time | $t_{clkp} * 0.4$ | | $t_{clkp} * 0.6$ | ns | |
| t_{su} | TXD[3:0], TXEN, TXER setup time to rising edge of TXCLK | 12.0 | | | ns | Note 5.16 |
| t_{hold} | TXD[3:0], TXEN, TXER hold time after rising edge of TXCLK | 0 | | | ns | Note 5.16 |
| t_1 | TXCLK rising edge after TXEN assertion to RXDV assertion (100 Mbps internal loopback mode) | 160 | | 162 | ns | Note 5.16 |

Note 5.15 40 ns for 100BASE-TX operation, 400 ns for 10BASE-T operation.

Note 5.16 Timing was designed for system load between 10 pF and 25 pF.

5.6.3.1 100 Mbps Internal Loopback MII Timing

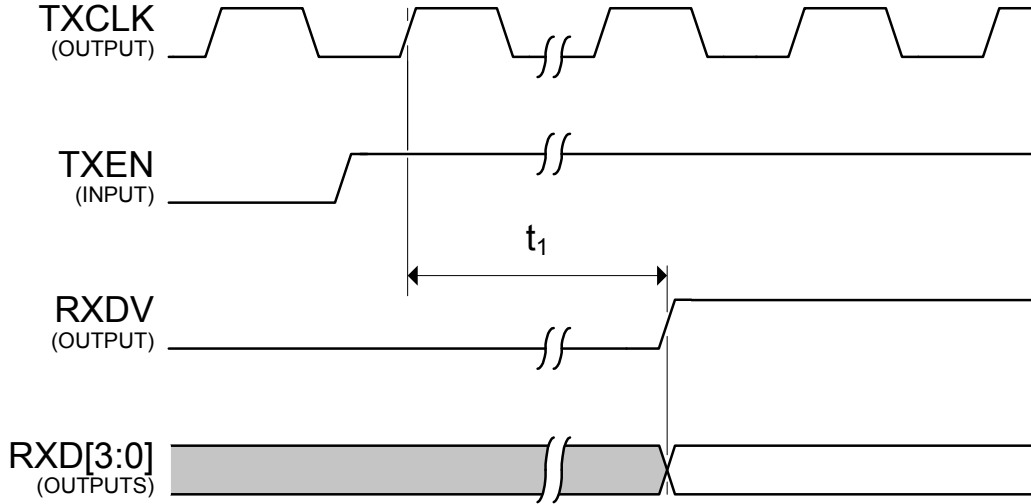

Figure 5.5 100 Mbps Internal Loopback MII Timing

Table 5.11 100 Mbps Internal Loopback MII Timing Values

| SYMBOL | DESCRIPTION | MIN | TYPICAL | MAX | UNITS |
|--------|--|-----|---------|-----|-------|
| t_1 | TXCLK rising edge after TXEN assertion to RXDV assertion (100 Mbps internal loopback MII mode) | 160 | 161 | 162 | ns |

Note: The t_1 measurement applies in MII mode when the [Loopback](#) bit of the [Basic Control Register](#) is set to “1” and a link has been established in 100 Mb full-duplex mode. The t_1 measurement is taken from the first rising edge of TXCLK following assertion of TXEN to the rising edge of RXDV.

5.6.4 RMII Interface Timing

This section specifies the RMII interface transmit and receive timing.

Note: The CRS_DV pin performs both carrier sense and data valid functions. CRS_DV is asserted asynchronously on detection of carrier due to the criteria relevant to the operating mode. If the PHY has additional bits to be presented on RXD[1:0] following the initial deassertion of CRS_DV, then the device will assert CRS_DV on cycles of REF_CLK which present the second di-bit of each nibble and deassert CRS_DV on cycles of REF_CLK which present the first di-bit of a nibble. For additional information, refer to the RMII specification.

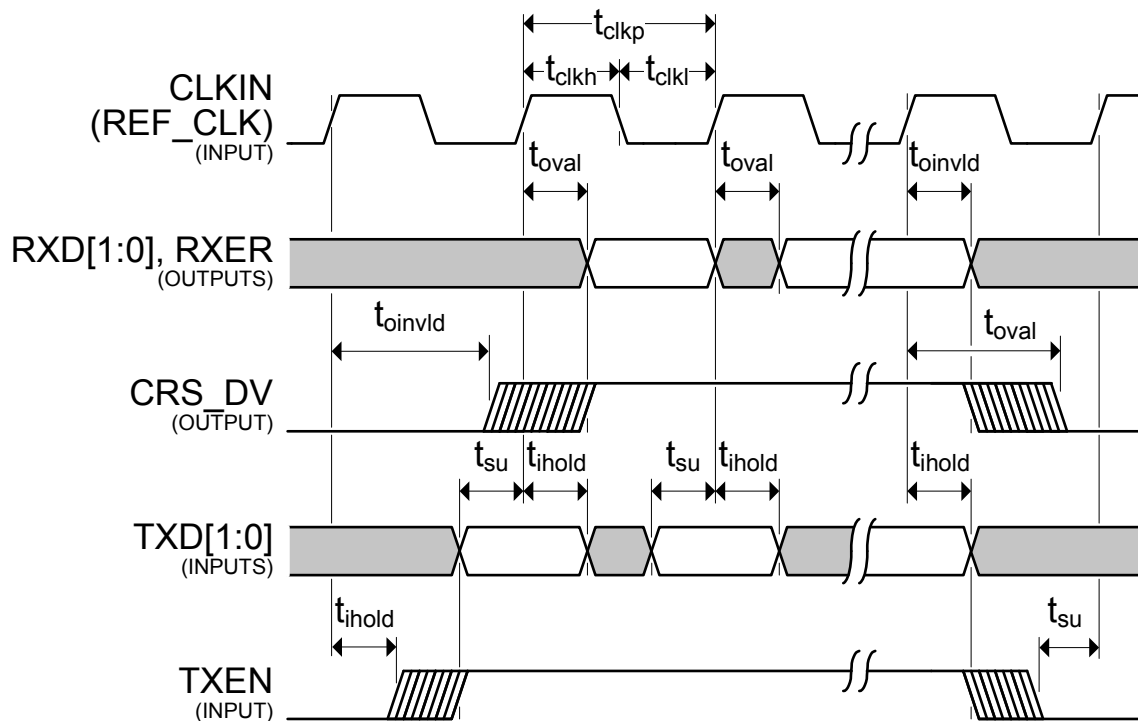

Figure 5.6 RMII Timing

Table 5.12 RMII Timing Values

| SYMBOL | DESCRIPTION | MIN | TYP | MAX | UNITS | NOTES |
|--------------|---|-------------------|-----|-------------------|-------|-----------|
| t_{clkp} | CLKIN period | 20 | | | ns | |
| t_{clkh} | CLKIN high time | $t_{clkp} * 0.35$ | | $t_{clkp} * 0.65$ | ns | |
| t_{clkl} | CLKIN low time | $t_{clkp} * 0.35$ | | $t_{clkp} * 0.65$ | ns | |
| t_{oval} | RXD[1:0], RXER, CRS_DV output valid from rising edge of CLKIN | | | 15.0 | ns | Note 5.17 |
| t_{oinvld} | RXD[1:0], RXER, CRS_DV output invalid from rising edge of CLKIN | 3.0 | | | ns | Note 5.17 |
| t_{su} | TXD[1:0], TXEN setup time to rising edge of CLKIN | 4.0 | | | ns | Note 5.17 |
| t_{ihold} | TXD[1:0], TXEN input hold time after rising edge of CLKIN | 1.5 | | | ns | Note 5.17 |

Note 5.17 Timing was designed for system load between 10 pF and 25 pF.

5.6.4.1 RMII CLKIN Requirements

Table 5.13 RMII CLKIN (REF_CLK) Timing Values

| PARAMETER | MIN | TYP | MAX | UNITS | NOTES |
|-----------------------|-----|-----|-----|-------|---------------|
| CLKIN frequency | | 50 | | MHz | |
| CLKIN Frequency Drift | | | ±50 | ppm | |
| CLKIN Duty Cycle | 40 | | 60 | % | |
| CLKIN Jitter | | | 150 | ps | p-p – not RMS |

Datasheet

5.6.5 SMI Timing

This section specifies the SMI timing of the device. Please refer to [Section 3.5, "Serial Management Interface \(SMI\)," on page 35](#) for additional details.

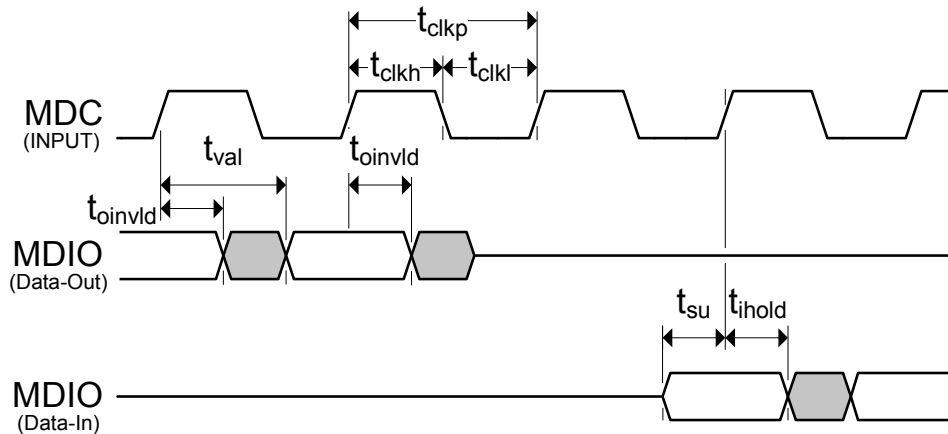

Figure 5.7 SMI Timing

Table 5.14 SMI Timing Values

| SYMBOL | DESCRIPTION | MIN | MAX | UNITS |
|--------------|--|-----------|-----|-------|
| t_{clkp} | MDC period | 400 | | ns |
| t_{clkh} | MDC high time | 160 (80%) | | ns |
| t_{clkl} | MDC low time | 160 (80%) | | ns |
| t_{val} | MDIO (read from PHY) output valid from rising edge of MDC | | 300 | ns |
| t_{oinvld} | MDIO (read from PHY) output invalid from rising edge of MDC | 0 | | ns |
| t_{su} | MDIO (write to PHY) setup time to rising edge of MDC | 10 | | ns |
| t_{ihold} | MDIO (write to PHY) input hold time after rising edge of MDC | 10 | | ns |

5.7 Clock Circuit

The device can accept either a 25 MHz crystal or a 25 MHz single-ended clock oscillator (± 50 ppm) input. If the single-ended clock oscillator method is implemented, XTAL2 should be left unconnected and XTAL1/CLKIN should be driven with a clock signal that adheres to the specifications outlined throughout [Chapter 5, Operational Characteristics](#). See [Table 5.15](#) for the recommended crystal specifications.

Table 5.15 Crystal Specifications

| PARAMETER | SYMBOL | MIN | NOM | MAX | UNITS | NOTES |
|-------------------------------|------------------------|---------------------------|--------------|---------------------------|----------|---------------------------|
| Crystal Cut | AT, typ | | | | | |
| Crystal Oscillation Mode | Fundamental Mode | | | | | |
| Crystal Calibration Mode | Parallel Resonant Mode | | | | | |
| Frequency | F_{fund} | - | 25.000 | - | MHz | |
| Frequency Tolerance at 25°C | F_{tol} | - | - | ± 50 | ppm | Note 5.18 |
| Frequency Stability Over Temp | F_{temp} | - | - | ± 50 | ppm | Note 5.18 |
| Frequency Deviation Over Time | F_{age} | - | ± 3 to 5 | - | ppm | Note 5.19 |
| Total Allowable PPM Budget | | - | - | ± 50 | ppm | Note 5.20 |
| Shunt Capacitance | C_O | - | 7 typ | - | pF | |
| Load Capacitance | C_L | - | 20 typ | - | pF | |
| Drive Level | P_W | 300 | - | - | μW | |
| Equivalent Series Resistance | R_1 | - | - | 30 | Ω | |
| Operating Temperature Range | | Note 5.21 | - | Note 5.22 | °C | |
| XTAL1/CLKIN Pin Capacitance | | - | 3 typ | - | pF | Note 5.23 |
| XTAL2 Pin Capacitance | | - | 3 typ | - | pF | Note 5.23 |

Note 5.18 The maximum allowable values for frequency tolerance and frequency stability are application dependant. Since any particular application must meet the IEEE ± 50 ppm Total PPM Budget, the combination of these two values must be approximately ± 45 ppm (allowing for aging).

Note 5.19 Frequency Deviation Over Time is also referred to as Aging.

Note 5.20 The total deviation for the Transmitter Clock Frequency is specified by IEEE 802.3u as ± 100 ppm.

Note 5.21 0°C for commercial version, -40°C for industrial version

Note 5.22 +70°C for commercial version, +85°C for industrial version

Note 5.23 This number includes the pad, the bond wire and the lead frame. PCB capacitance is not included in this value. The XTAL1/CLKIN pin, XTAL2 pin and PCB capacitance values are required to accurately calculate the value of the two external load capacitors. The total load capacitance must be equivalent to what the crystal expects to see in the circuit so that the crystal oscillator will operate at 25.000 MHz.

Datasheet

Chapter 6 Package Outline

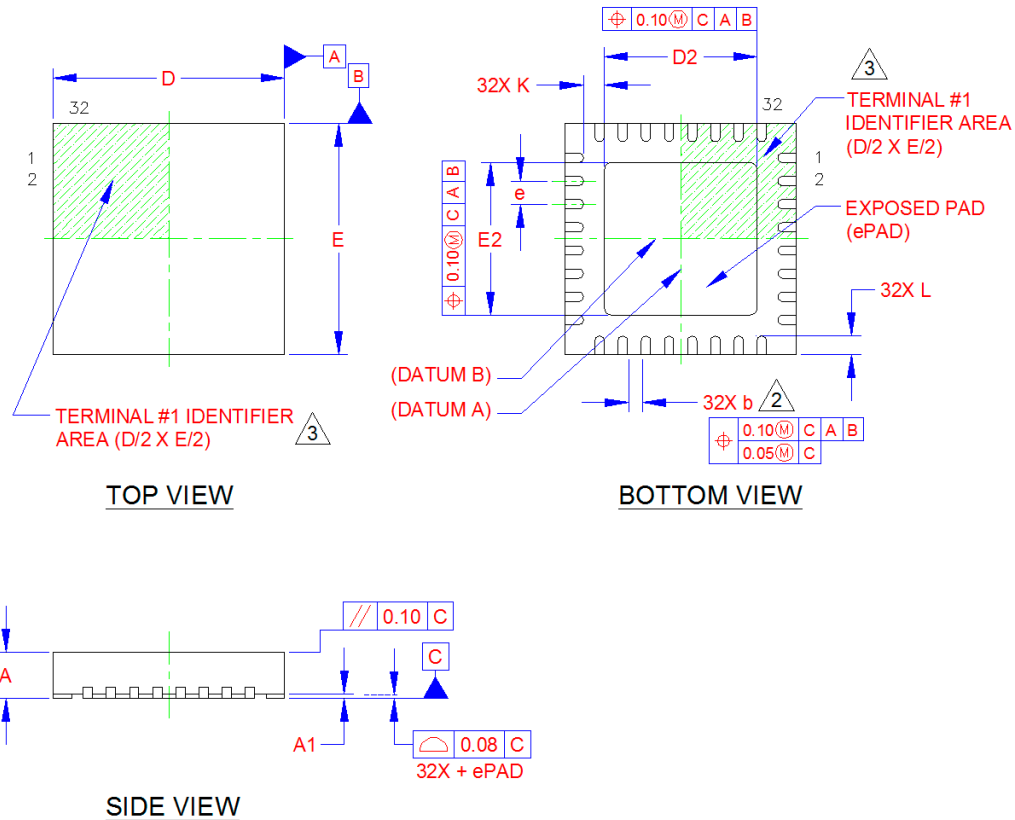

Figure 6.1 32-SQFN Package

Table 6.1 32-SQFN Dimensions

| | MIN | NOMINAL | MAX | REMARKS |
|-------|----------|---------|------|------------------------------|
| A | 0.80 | 0.90 | 1.00 | Overall Package Height |
| A1 | 0 | 0.02 | 0.05 | Standoff |
| D/E | 4.90 | 5.00 | 5.10 | X/Y Body Size |
| D2/E2 | 3.20 | 3.30 | 3.40 | X/Y Exposed Pad Size |
| L | 0.35 | 0.40 | 0.45 | Terminal Length |
| b | 0.18 | 0.25 | 0.30 | Terminal Width |
| k | 0.35 | 0.45 | - | Pin to Exposed Pad Clearance |
| e | 0.50 BSC | | | Terminal Pitch |

Notes:

1. All dimensions are in millimeters unless otherwise noted.
2. Dimension "b" applies to plated terminals and is measured between 0.15 and 0.30 mm from the terminal tip.
3. The pin 1 identifier may vary, but is always located within the zone indicated.

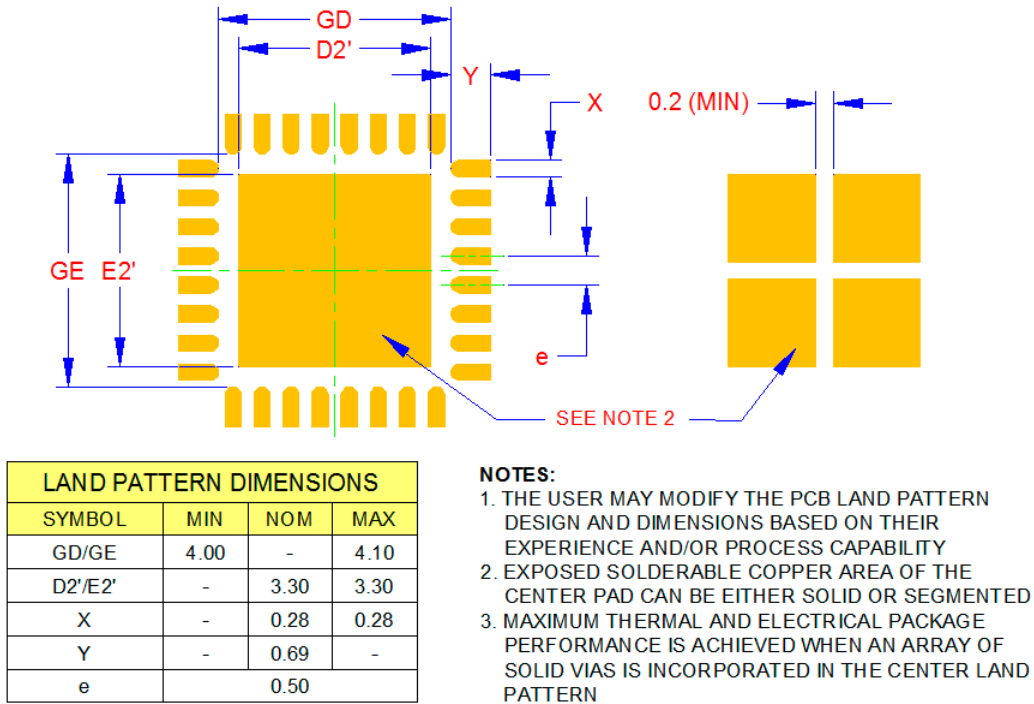

Figure 6.2 Recommended PCB Land Pattern

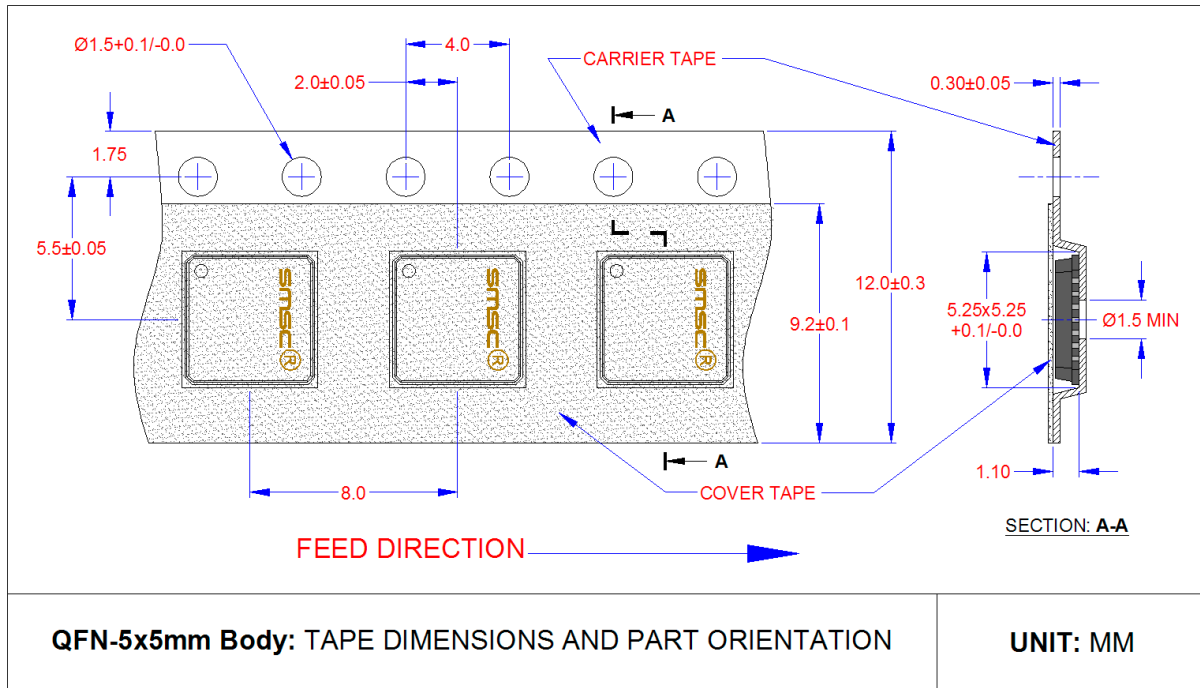

Figure 6.3 Taping Dimensions and Part Orientation

Datasheet

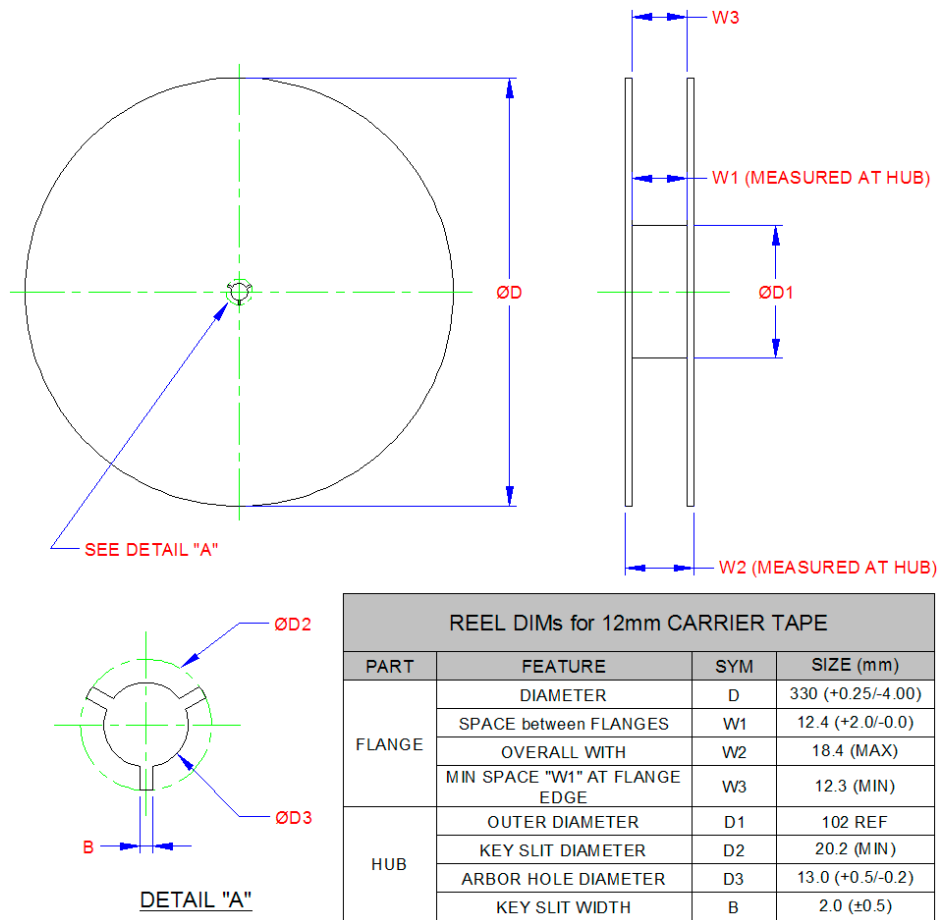

Figure 6.4 Reel Dimensions

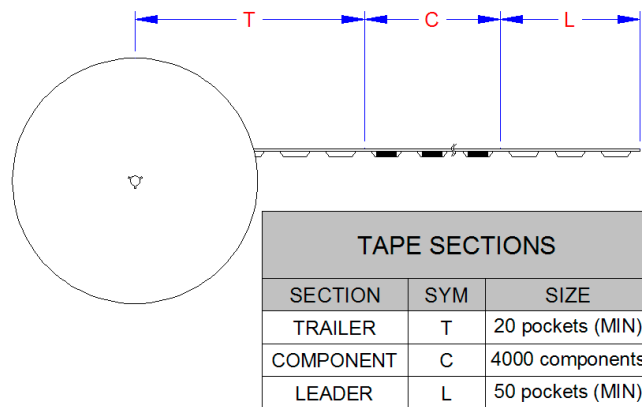

Figure 6.5 Tape Length and Part Quantity

Note: Standard reel size is 4,000 pieces per reel.

Chapter 7 Revision History

Table 7.1 Customer Revision History

| REVISION LEVEL & DATE | SECTION/FIGURE/ENTRY | CORRECTION |
|---|---|--|
| Rev. 1.1 (05-10-13) | General | <ul style="list-style-type: none"> ■ Changed part numbers from “LAN8740/LAN8740i” to “LAN8740A/LAN8740Ai” ■ Updated ordering information ■ Updated figures |
| | Cover | Added new bullet under Highlights section: “Deterministic 100 Mb internal loopback latency (MII Mode)” |
| | Chapter 2, Pin Description and Configuration, Table 2.1, “MII/RMII Signals,” on page 11 | Changed buffer type from “VIS (PU)” to “VIS” |
| | Chapter 2, Pin Description and Configuration, Table 2.3, “Serial Management Interface (SMI) Pins,” on page 17 | <ul style="list-style-type: none"> ■ Added pull-up to MDIO buffer type description ■ Changed “VIS/VOD8 (PU)” to “VIS/VO8 (PU)” |
| | Section 3.3, “HP Auto-MDIX Support,” on page 31 | Changed “100BASE-T” to “100BASE-TX” |
| | Section 3.4.2.1, “CRS_DV - Carrier Sense/Receive Data Valid,” on page 33 | Changed “100BASE-X” to “100BASE-TX” |
| | Section 3.5, “Serial Management Interface (SMI),” on page 35 | Removed sentence stating “Non-supported registers (such as 7 to 15) will be read as hexadecimal “FFFF”. |
| | Section 3.8.11, “Cable Diagnostics,” on page 56 | Updated section with additional operation details |
| | Section 3.8.12.1, “Near-end Loopback,” on page 61 | Added cross-reference to 100 Mbps internal loopback timing section |
| | Chapter 4, “Register Descriptions,” on page 68 | Removed <ul style="list-style-type: none"> - TDR Channel Threshold Maximum Register - TDR Wait Counter Threshold Register - TDR TX Pattern Generator Divider Register |
| | Section 4.2.2, “Basic Status Register,” on page 71 | Updated definitions of bits 10:8 |
| | Section 4.2.18, “Special Control/Status Indications Register,” on page 88 | Updated bit 11 definition |
| Section 4.2.22, “PHY Special Control/Status Register,” on page 92 | Updated bit 6 definition | |
| Section 4.3, “MDIO Manageable Device (MMD) Registers,” on page 93 | Added additional vendor specific MMD register descriptions | |

Datasheet

Table 7.1 Customer Revision History (continued)

| REVISION LEVEL & DATE | SECTION/FIGURE/ENTRY | CORRECTION |
|---|--|--|
| Rev. 1.1 (05-10-13) | Section 4.3.11, "MAC Receive Address A Register (RX_ADDRA)" | Added note |
| | Section 4.3.12, "MAC Receive Address B Register (RX_ADDRB)" | Added note |
| | Section 4.3.13, "MAC Receive Address C Register (RX_ADDR_C)" | Added note |
| | Chapter 5, "Operational Characteristics," on page 124 | Removed section "Power Sequence Timing" |
| | Section 5.1, "Absolute Maximum Ratings*," on page 124 | Changed: Positive voltage on XTAL1/CLKIN, with respect to ground from "VDDCR" to "+3.6V" |
| | Section 5.3, Table 5.1, "Package Thermal Parameters," on page 125 | Updated package thermal specification values |
| | Section 5.4, "Power Consumption," on page 126 | Updated power numbers |
| | Section 5.5, "DC Specifications," on page 127 | Changed V_{IH} max of ICLK Type Buffer from "VDDCR" to "3.6" |
| | Section 5.6, "AC Specifications," on page 129 | Removed two RMII notes at beginning of section |
| | Section 5.6.3.1, "100 Mbps Internal Loopback MII Timing," on page 133 | Added new 100 Mbps internal loopback timing section and diagram |
| Section 5.6.4, "RMII Interface Timing," on page 134 | <ul style="list-style-type: none"> ■ Added note detailing CRS_DV behavior as both carrier sense and data valid ■ Updated RMII timing table | |
| Rev. 1.0 (05-11-12) | Initial Release | |