

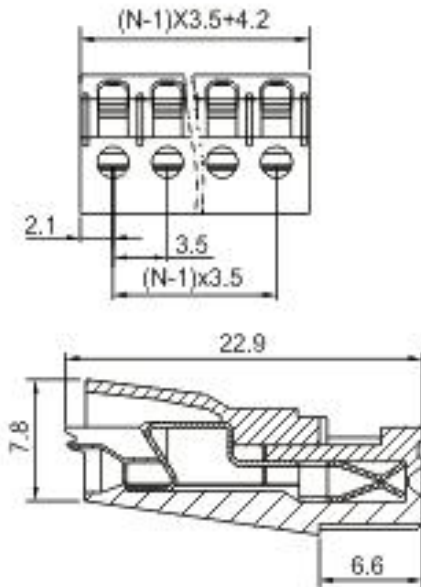





15EDGKN-3.5

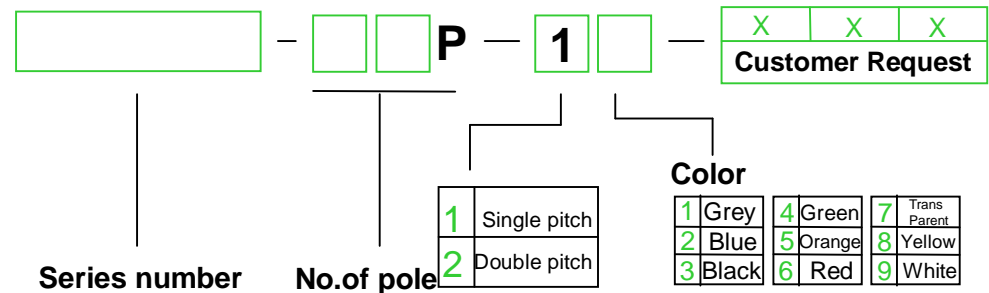

APPROVAL		
Electrical		
Standard	UL	IEC
Rated voltage	300V	250V
Rated current	8A	7A
Wire range	28-16AWG	0.5-1.5mm ²
Withstanding voltage	AC2000V/1Min	
Mechanical		
Ambient temperature	-40°C~+105 °C	
Strip length	10mm	
Dimensions		
Pitch	3.5mm(.138")	
Poles	2P-24P	
Material		
Housing	PA66,UL94V-0	
Contact	Phosphor bronze	
Wire guard	Stainless steel	

HOW TO ORDER :

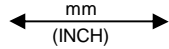

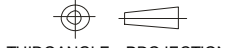
 mm (INCH)	 DEGSON ELECTRONICS CO., LTD.
 THROATLE PROJECTION	NAME 15EDGKN-3.5