

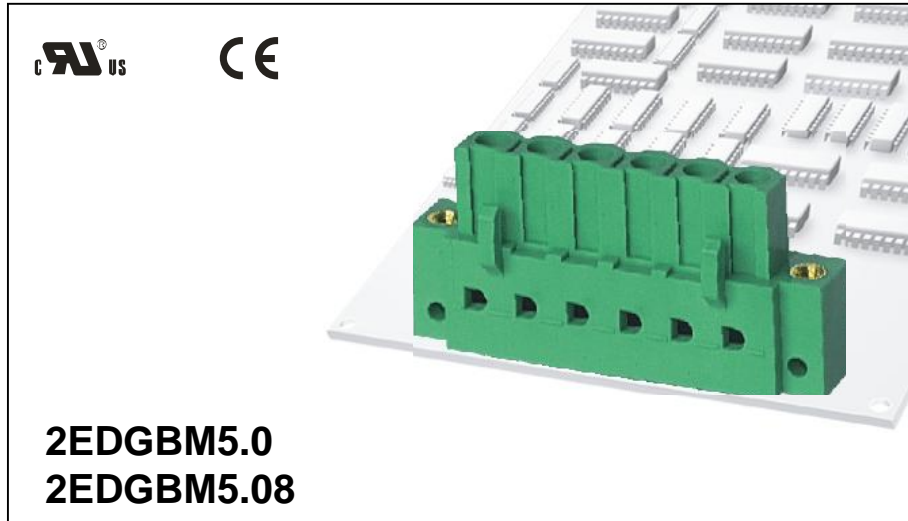

DEGSON ELECTRONICS CO., LTD.

Product Specification



APPROVAL		
Electrical		
Standard	UL	IEC
Rated voltage	300V	320V
Rated current	15A	20A
Withstanding voltage	AC2500V/1Min	
Mechanical		
Ambient temperature	-40°C~+105 °C	
Dimensions		
Pitch	5.0mm(.197)5.08mm(.200")	
Poles	2P-22P	
Material		
Housing	PA66,UL94 V-0	
Contact	Phosphor bronze,Tin plated	
Nut	M2.5,Brass	

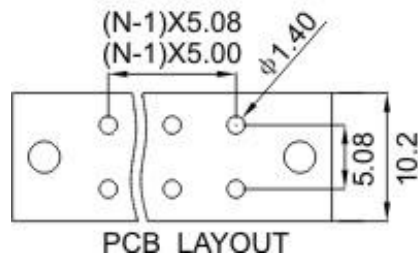
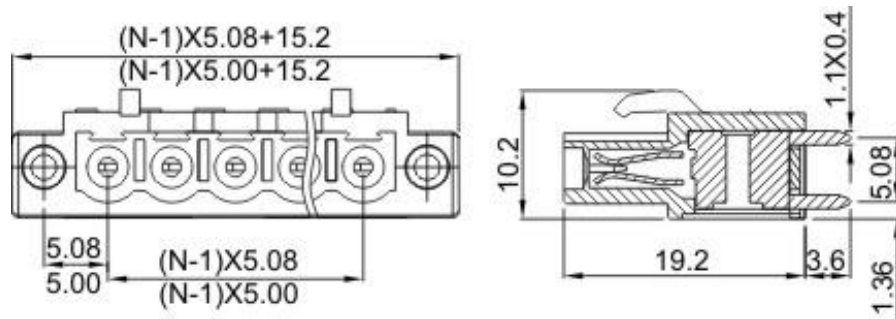

HOW TO ORDER :

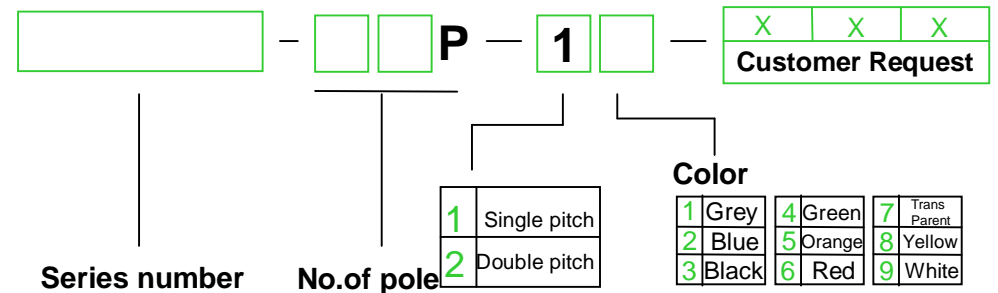

 mm (INCH)	 DEGSON ELECTRONICS CO., LTD.
 THROANGLE PROJECTION	NAME 2EDGBM-5.0 2EDGBM-5.08