

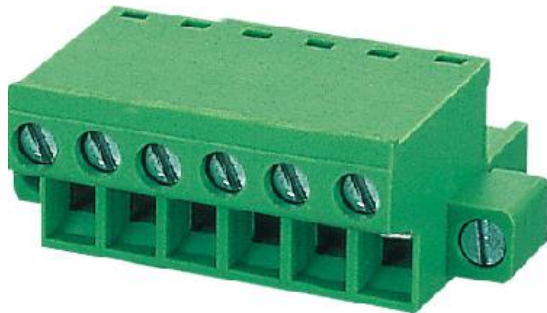

DEGSON ELECTRONICS CO., LTD.

Product Specification



2EDGKCM-5.0
2EDGKCM-5.08

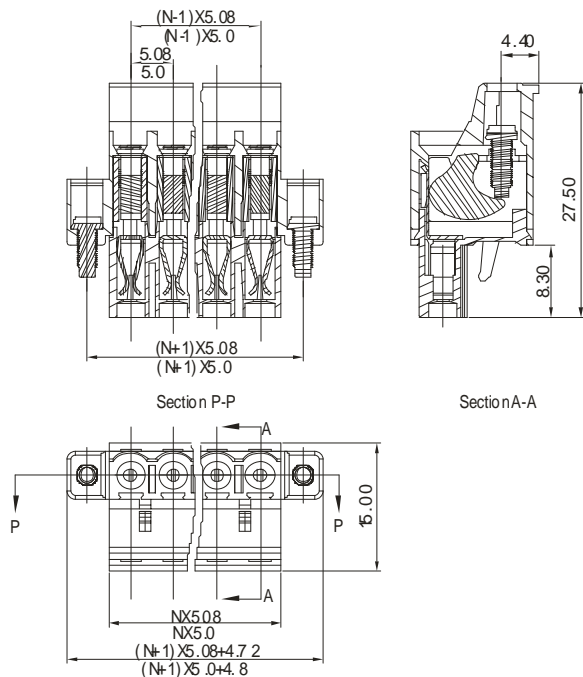

APPROVAL		
Electrical		
Standard	UL	IEC
Rated voltage	300V	320V
Rated current	10A	20A
Wire range	28-12AWG	2.5mm ²
Withstanding voltage	AC2500V/1Min	
Mechanical		
Torque	0.4Nm(3.5Lb-In)	
Ambient temperature	-40°C~+105 °C	
Strip length	10mm	
Dimensions		
Pitch	5.0mm(.197") 5.08mm(.200")	
Poles	2P-20P	
Material		
Housing	PA66,UL94 V-0	
Screws	M2.5,Steel,Cr ³⁺ Zn-plated	
Contact	Phosphor bronze	
Cage	Steel,Cr ³⁺ Zn-plated	

HOW TO ORDER :

- **P** - -

X	X	X
---	---	---

Customer Request

Series number | **No. of pole** | **Color**

1	Single pitch
2	Double pitch

1	Grey	4	Green	7	Trans Parent
2	Blue	5	Orange	8	Yellow
3	Black	6	Red	9	White

 mm (INCH)	 DEGSON ELECTRONICS CO., LTD.
 THROANGLE PROJECTION	NAME 2EDGKCM-5.0 2EDGKCM-5.08