

REVISION RECORD

REV	ECN	DESCRIPTION	DRFT	DATE
-----	-----	-------------	------	------

NOTES1:

UL Standard

1. Rated voltage/current : 300V / 15A
2. Withstanding voltage : AC1600V/1Min.
3. Wire range : 22~14AWG

IEC Standard

1. Pollution Degree	3
Overvoltage Category	III
Rate Impulse Voltage(KV)	4.0KV
Rate Voltage(V)	320V
Rate Current(A)	20A

2. Wire range : 0.2~2.5mm²

NOTES2:

1. Dimension shall be interpreted per ASME Y14.5-2009
2. Pitch : 5.00mm, Poles : N=02~24P
3. Stripping length : 7~8mm
4. Operating temperature : -40°C~+105°C
5. Undimensioned tolerances:

Pitch range in mm		Nominal dimension range in mm				
TO	Over	TO	Over	TO	Over	
6	10	10	30	60	100	150
6	10	24	30	60	100	150
±0.15	±0.20	±0.30	±0.30	±0.50	±0.70	±1.00
						±1.30
						±2*

6. RoHS Compliance

8EDG-STDD - 5.0 - XXP - 1Y - 00A (H)
 (Series No.) (Pitch)(Poles)(Single Pitch) (Color) : 1.(Grey)
 2.(Blue)
 3.(Black)
 4.(Green)
 5.(Orange)
 6.(Red)
 7.(Transparent)
 8.(Yellow)
 9.(White)

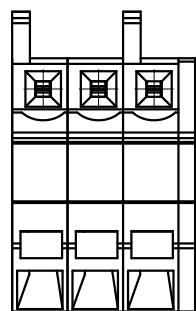
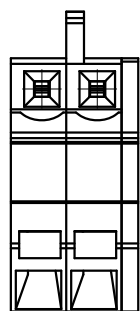
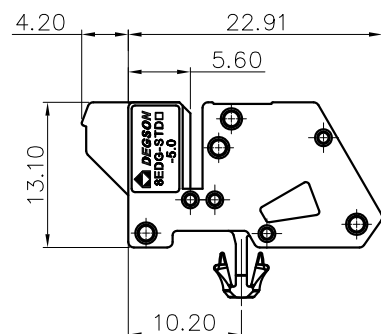
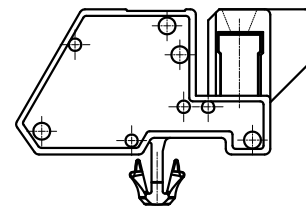
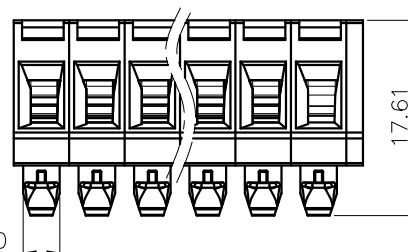
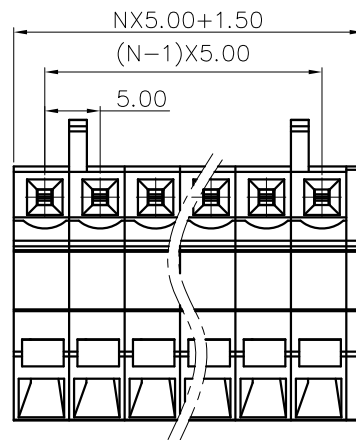

2P

3P

DETACHED LISTS	PART NO.:	/			
	APPD:	/			
	CHKD:	/			
	DRFT:	/			
		<p>THIRD ANGLE PROJECTION</p>		<p>DRAWING NO.:</p> <p>MM (INCH)</p>	<p>DO NOT SCALE DRAWING</p>
				<p>SCALE</p> <p>1:1</p>	<p>REV</p> <p>DO</p>
				<p>SHEET</p> <p>1/1</p>	<p>DATE</p>

宁波高松电子有限公司
 NINGBO DEGSON ELECTRICAL CO., LTD

8EDG-STDD-5.0-XXP-1Y-00A(H)

CUSTOMER DRAWING

DRAWING NO. /

DO NOT SCALE DRAWING

REV

DO

SHEET 1/1

SCALE 1:1

H
G
F
E
D
C
B
A

H
G
F
E
D
C
B
A