

PRZ WPS193P10Y/AL

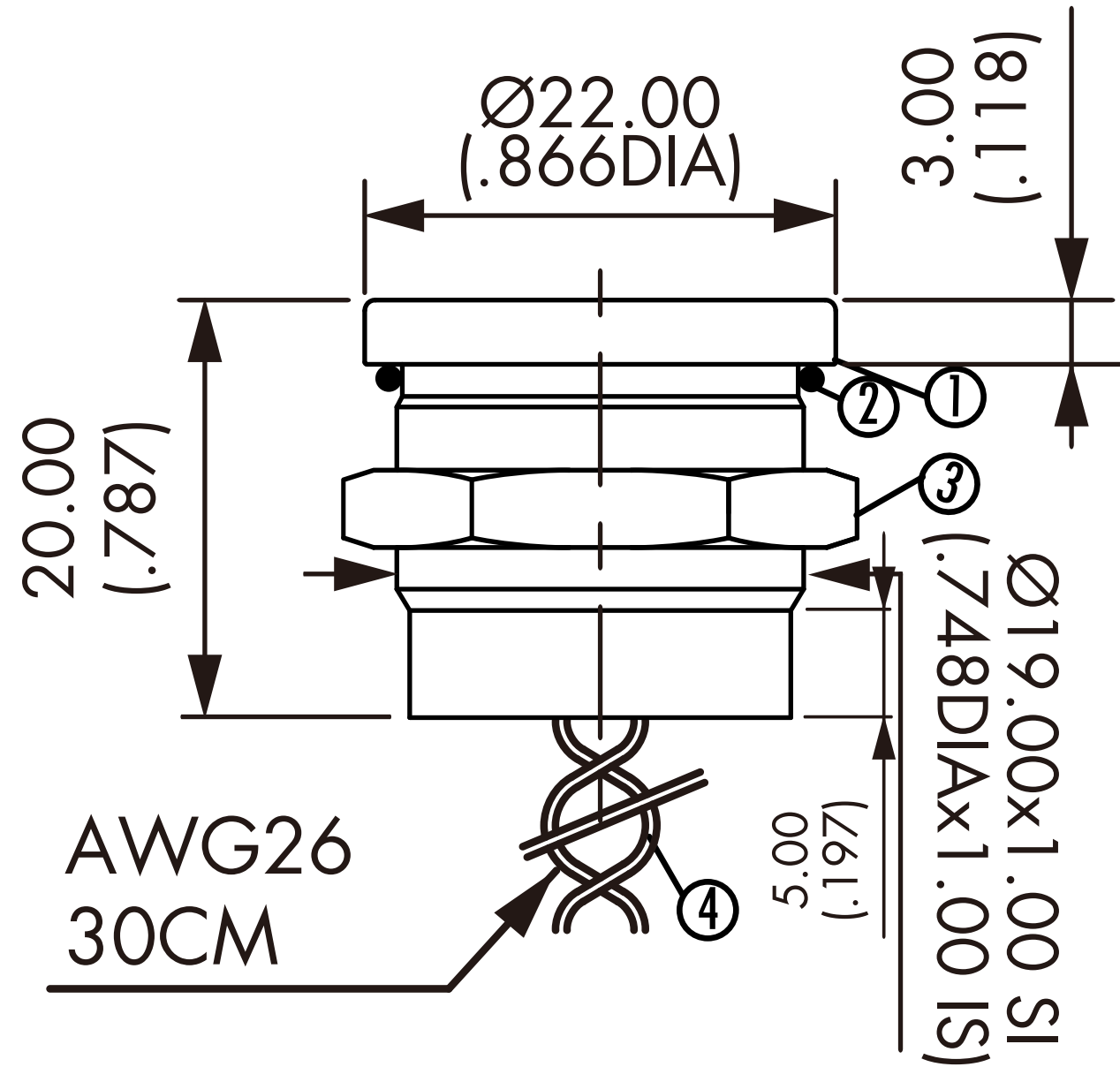

SPECIFICATIONS:

- HOUSING MATL.: ALUMINUM 6061 T651
- NUT MATERIAL: BRASS (Ni COATED)
- CONNECTION: 2 RED PVC WIRE AWG26 30CM (2PVC WIRES RED & RED FOR SW.)
- SWITCHING VOLTAGE: 1-24 V AC/DC
- MAX SWITCHING CURRENT: 200 mA
- SWITCH RESISTANCE "ON": <20 Ohm
- SWITCH RESISTANCE "OFF": >5 MOhm
- ACTUATION FORCE: 3 ~ 5 N
- N.O. CLOSING IMPULSE DURATION (DEPENDING ON ACTUATING FORCE, TIME, SPEED)
125 ~ 300 mSec.
- OPERATING TEMP.: -40 °C TO +70 °C
- STORAGE TEMP.: -40 °C TO +85 °C

FINISH:

- ANODIZE THICKNESS: 6-10µ
- ANODIZE COLOR: NATURALV

Millimetre Dimensions in Brackets

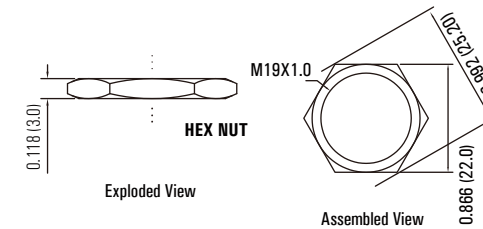

SWITCH SCHEME:

